



**BOSCH**

# AKKU-Příklepový šroubovák

GSB 18V-150 C | 3 601 JJ5 100

---

## Obsah

Nákres výrobku.....	2
---------------------	---

Nákres výrobku - E

3 601 JJ5 100

Stand } 21-03-02  
Issue } 21-05-14

Fig./Abb. 1

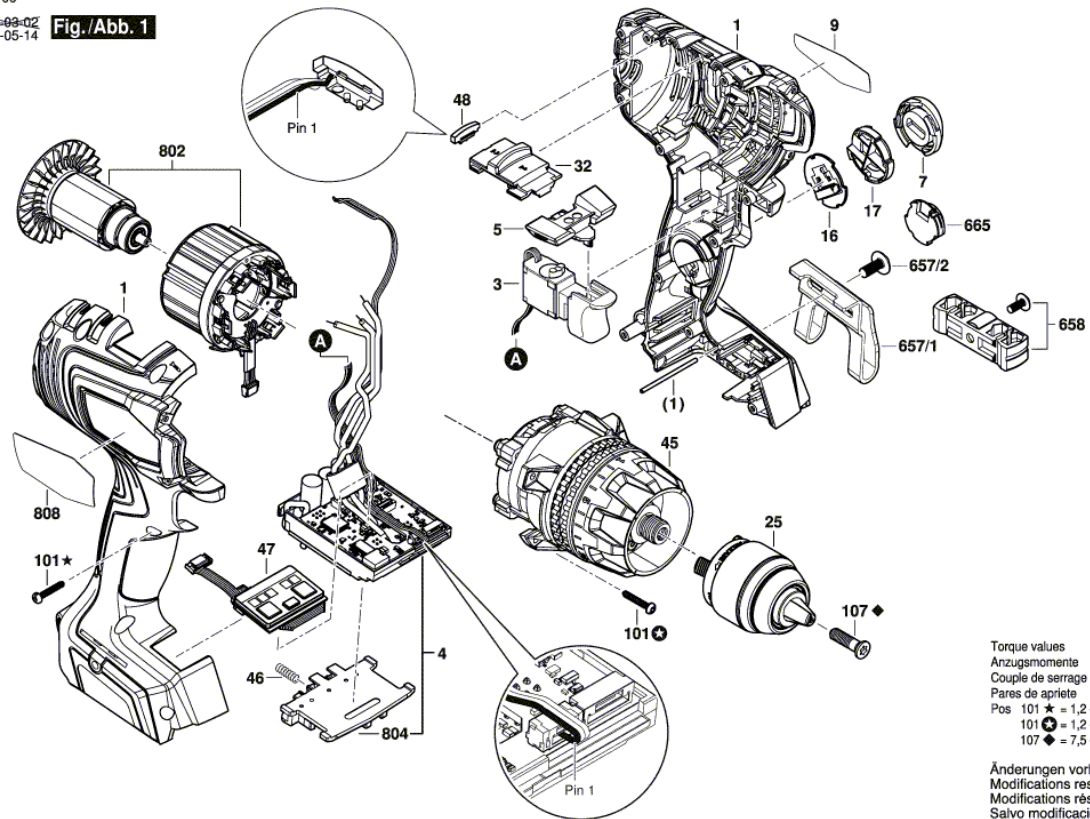

Torque values  
Anzugsmomente  
Couple de serrage  
Pares de apriete  
Pos 101 ★ = 1,2 - 1,4 Nm  
101 ★ = 1,2 - 1,4 Nm  
107 ◆ = 7,5 - 9,0 Nm

Änderungen vorbehalten  
Modifications reserved  
Modifications réservées  
Salvo modificaciones

Nákres výrobku - E

3 601 JJ5 100  
Stand }  
Issue } 21-02-25 **Fig./Abb. 2**

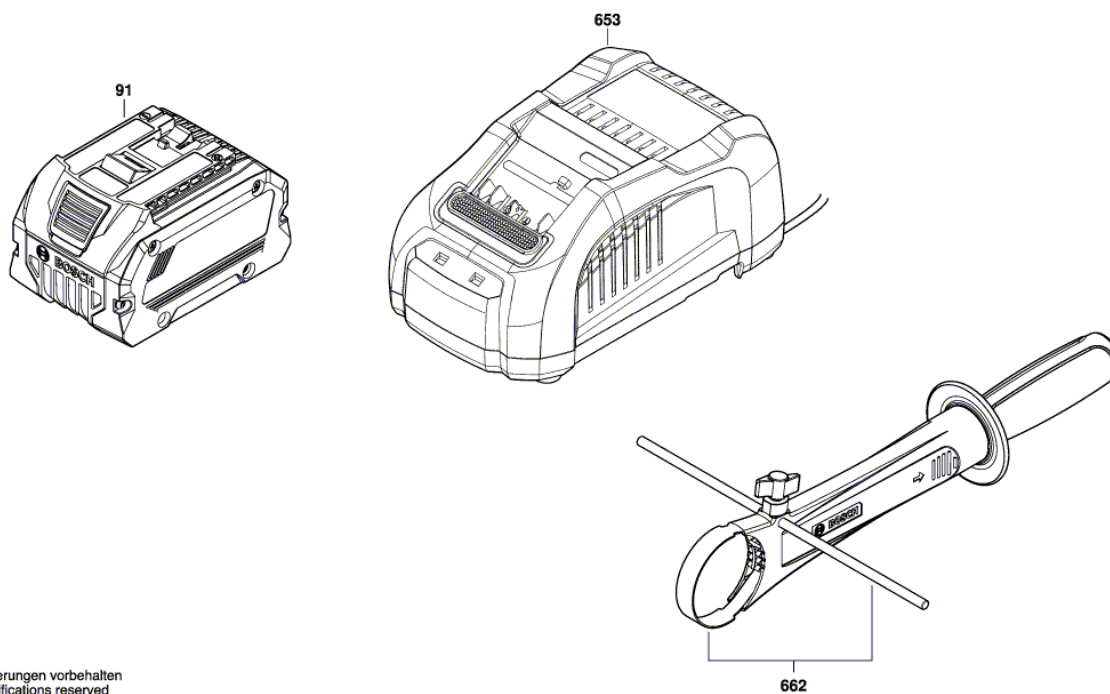

Änderungen vorbehalten  
Modifications reserved  
Modifications réservées  
Salvo modificaciones