

# TCB+TCN2

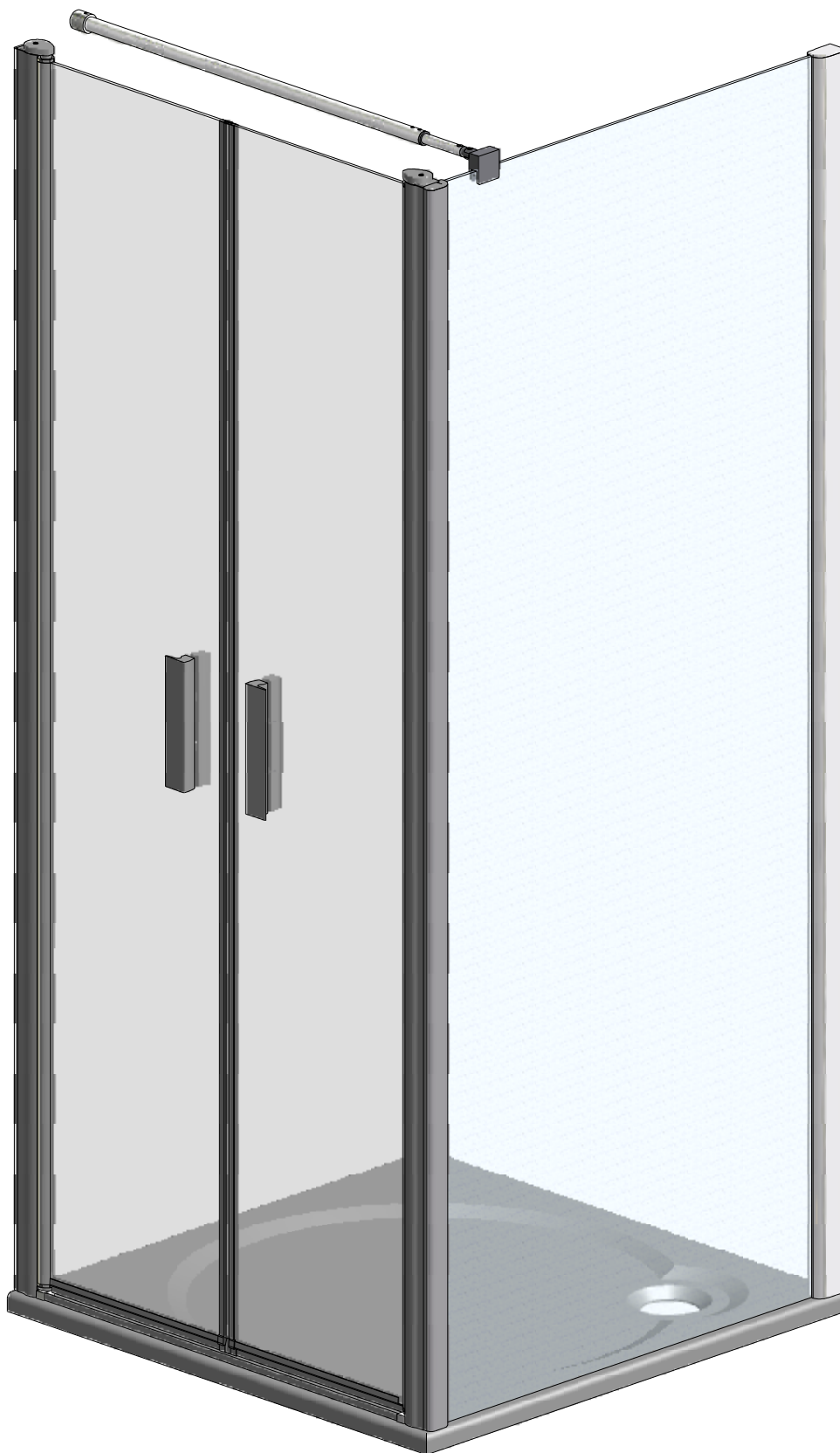

Roltechnik a.s.; Czech Republic, 56933 Třebařov 160,  
tel.:+420 461 324 301/302, fax: +420 461 324 297,  
<http://www.roltechnik.com>; e-mail: [objednavky@roltechnik.cz](mailto:objednavky@roltechnik.cz)

# TCB+TCN2

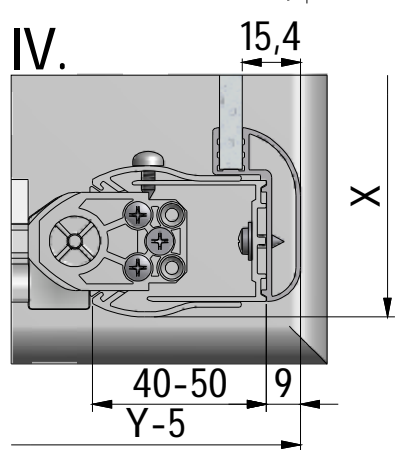
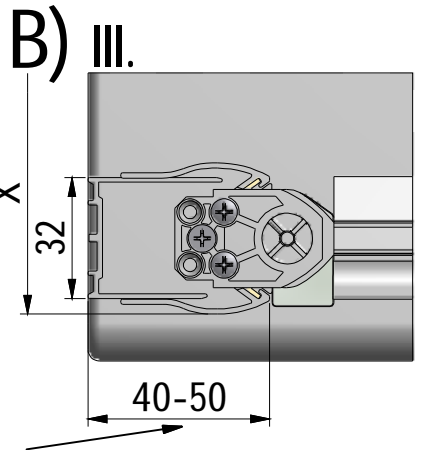
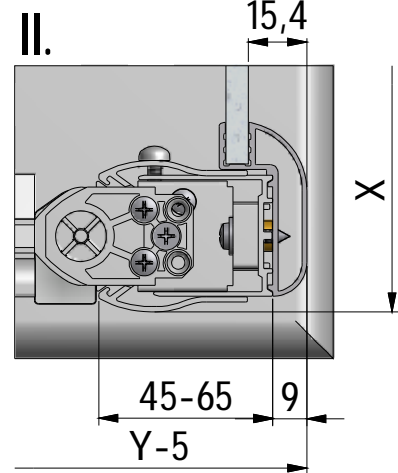
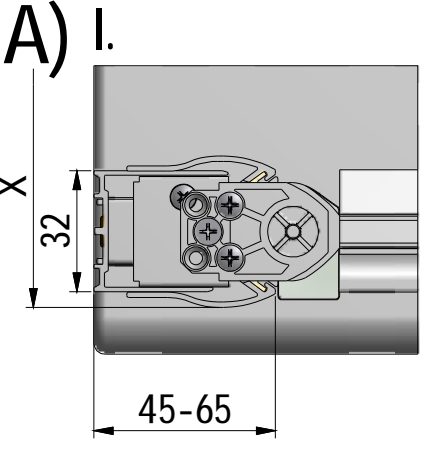
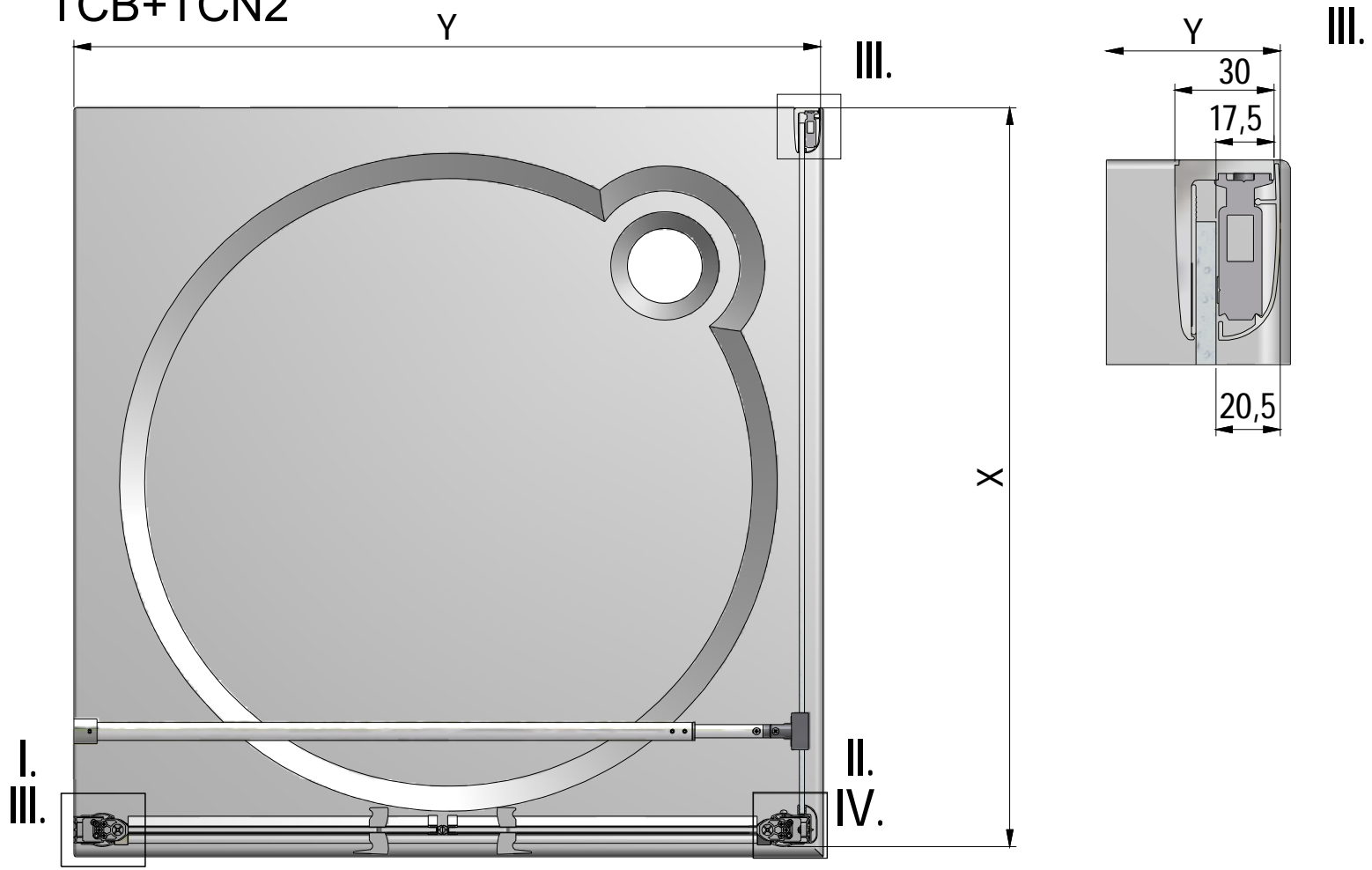

	X (mm)		Y (mm)	
	MIN	MAX	MIN	MAX
800	775	800	795	835
900	875	900	895	935
1000	975	1000	995	1035
1100	-	-	1095	1135
1200	-	-	1195	1235

U minima montovat bez čepu a plastového komponentu.  
 At a minimum installed without the pin and the plastic component.  
 Bei einem Minimum, ohne den Stift und der Kunststoffkomponente eingebaut.  
 Au minimum installé sans la broche et le composant en matière plastique.

1. 1x  
V127

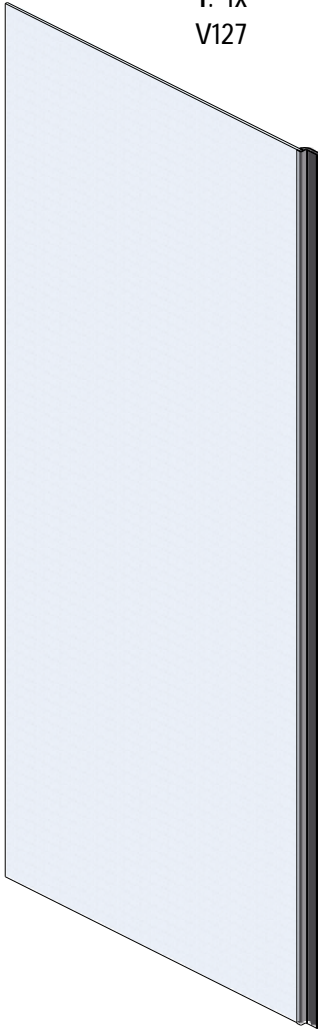

3. 1x



4. 1x  
P32



6. 4x  
M0511  
n6

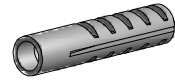

7. 4x  
M0811  
3,9x38



8. 4x  
M5974



9. 4x  
M5975



10. 4x  
M5924

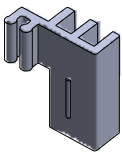

11. 4x  
M5925

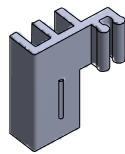

25. 1x  
M5926

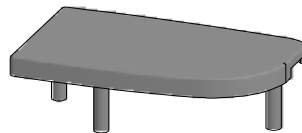

26. 1x  
M5927



12. 1x  
P2743



13. 1x  
MA1548

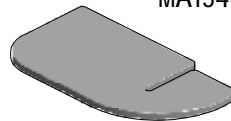

14. 1x  
MA1549

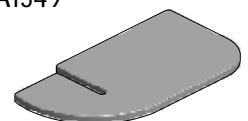

15. 6x  
M0806



16. 4x  
M0789



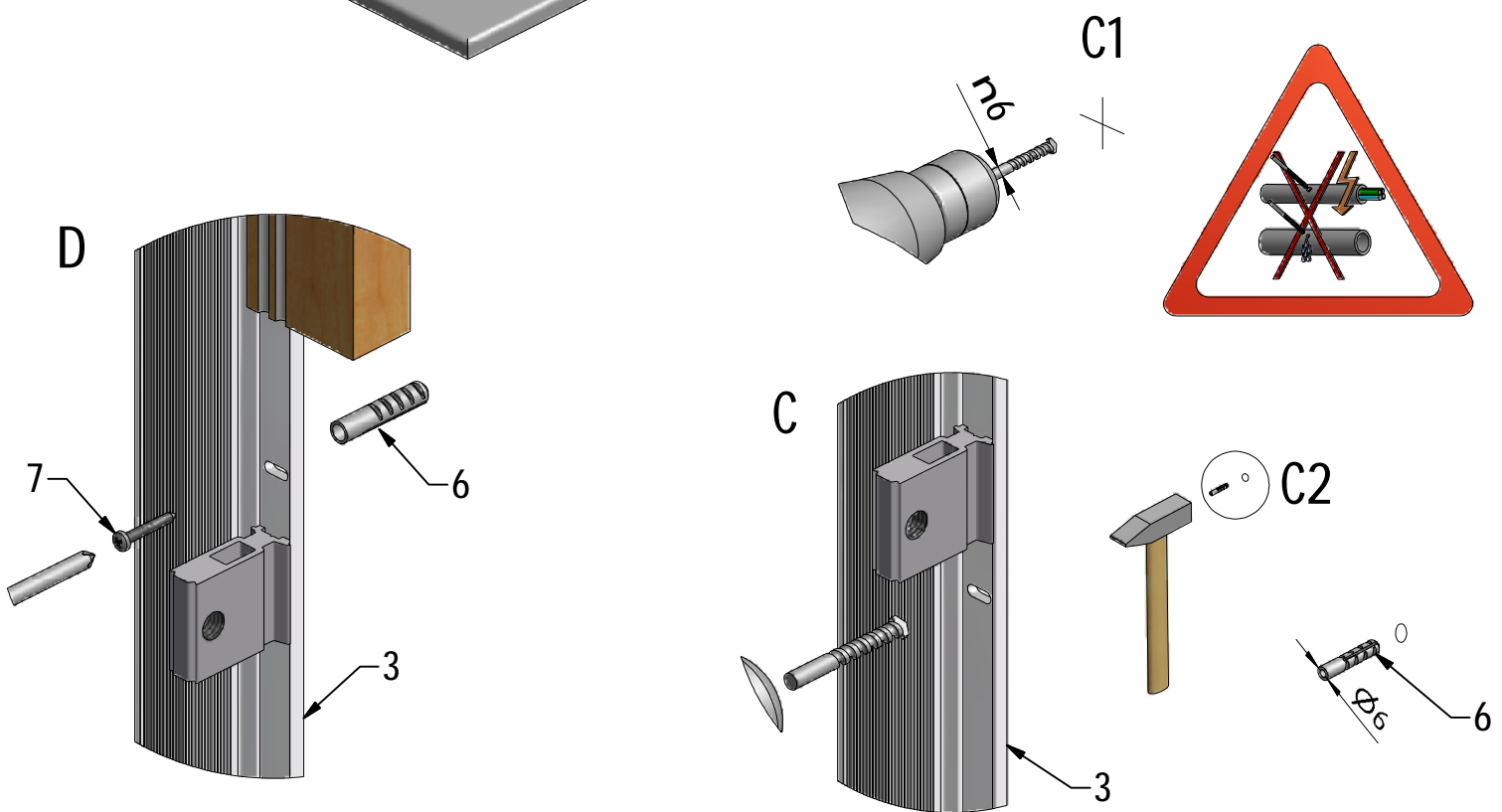
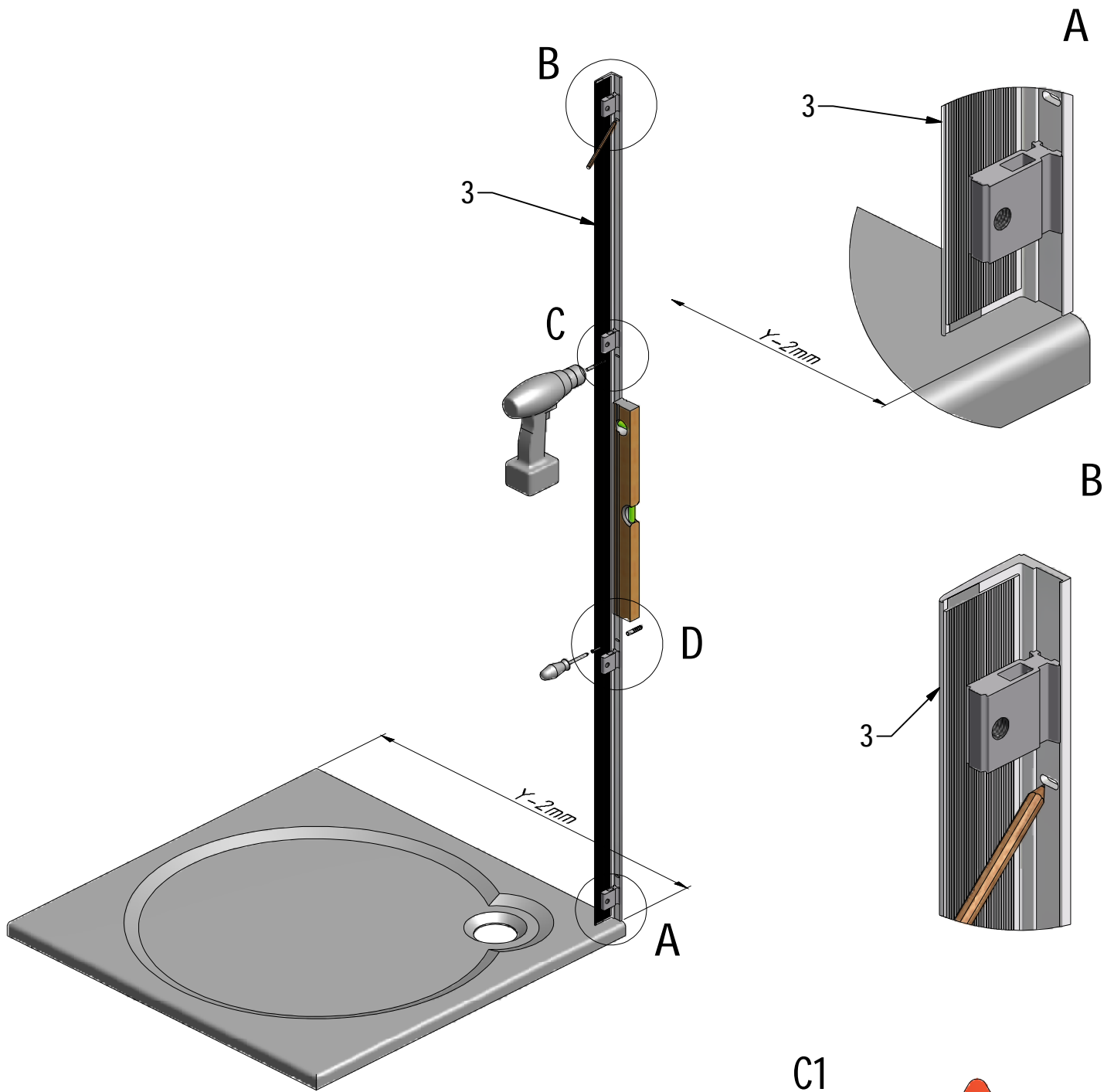

LEFT

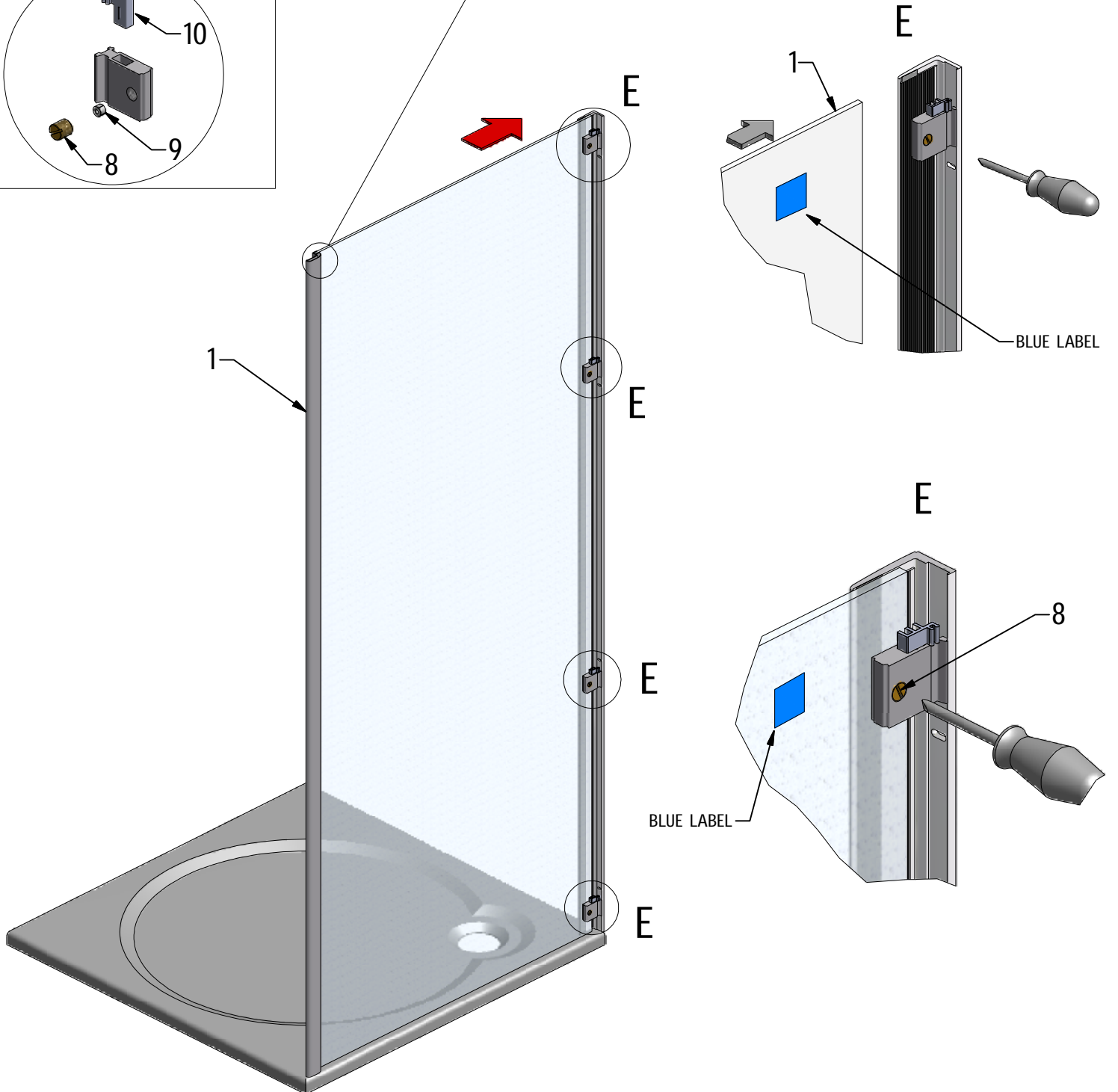
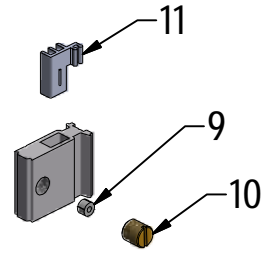
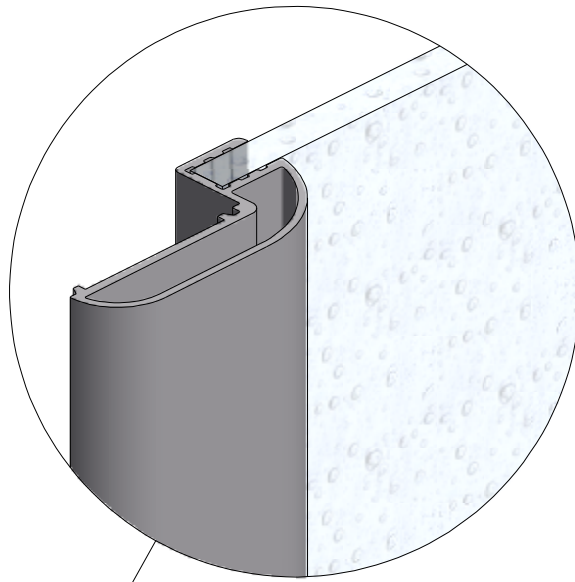
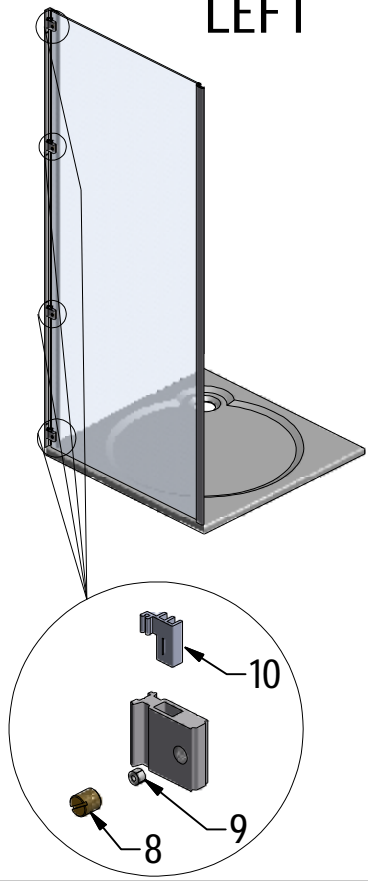

F ( 1 : 1,5 )

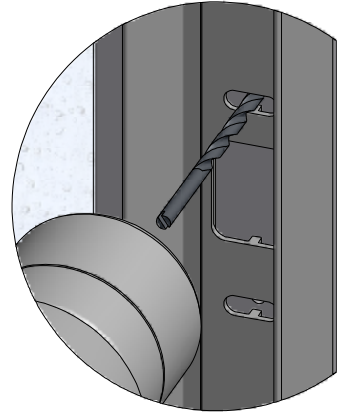

F

F ( 1 : 1 )

6x

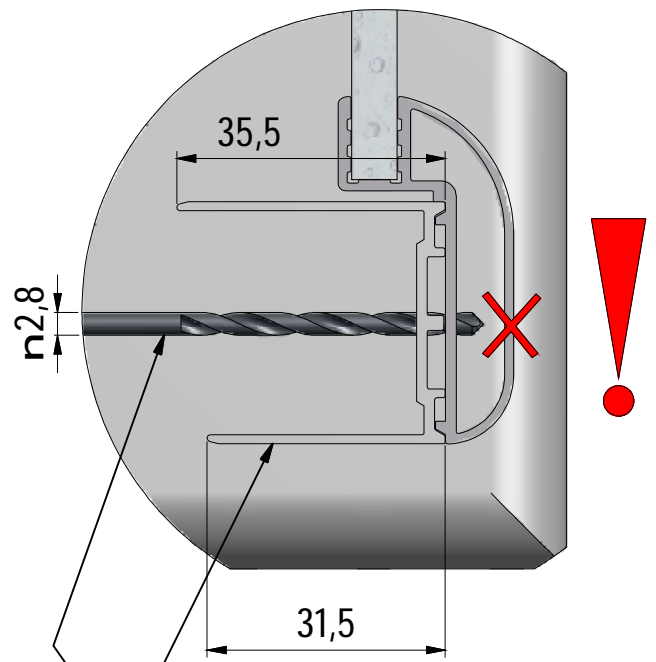

3 manual TCN2

25 manual TCN2

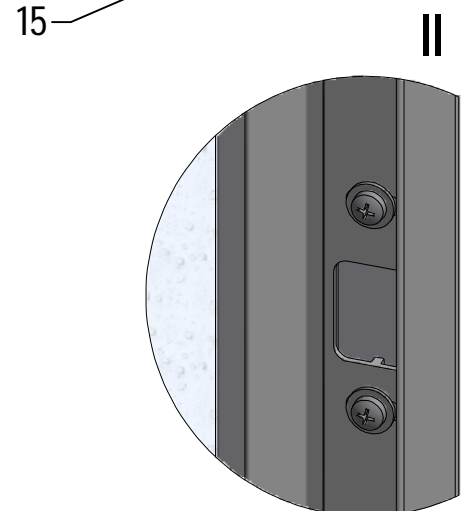
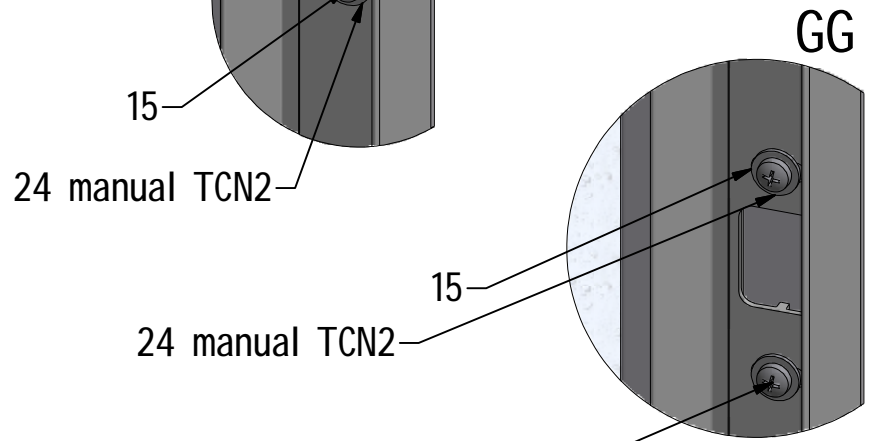
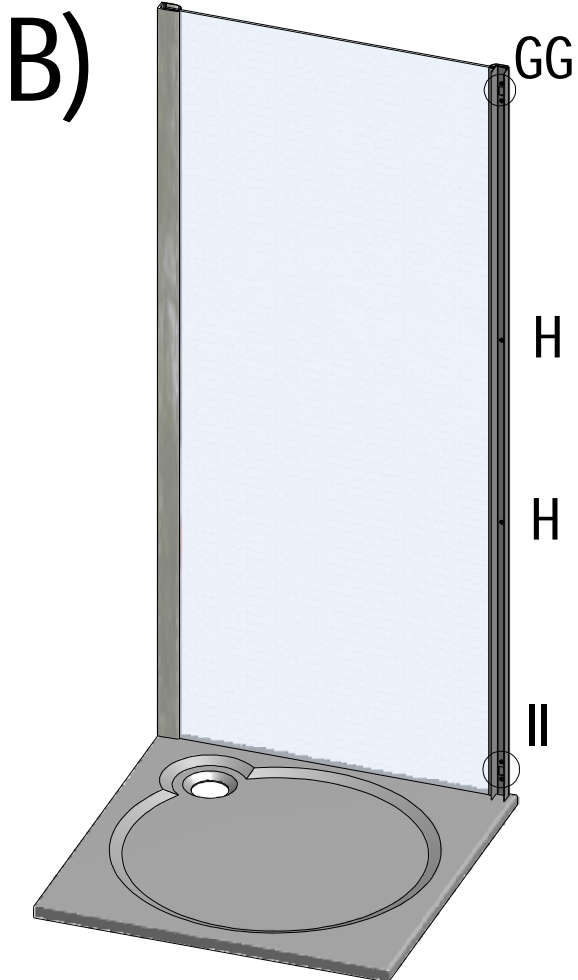
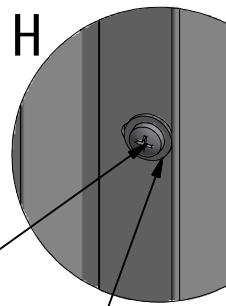
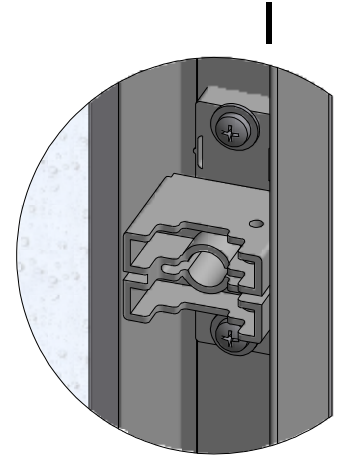
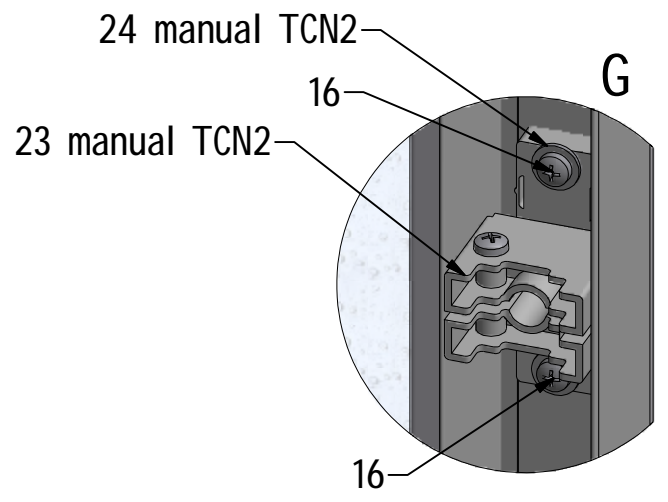
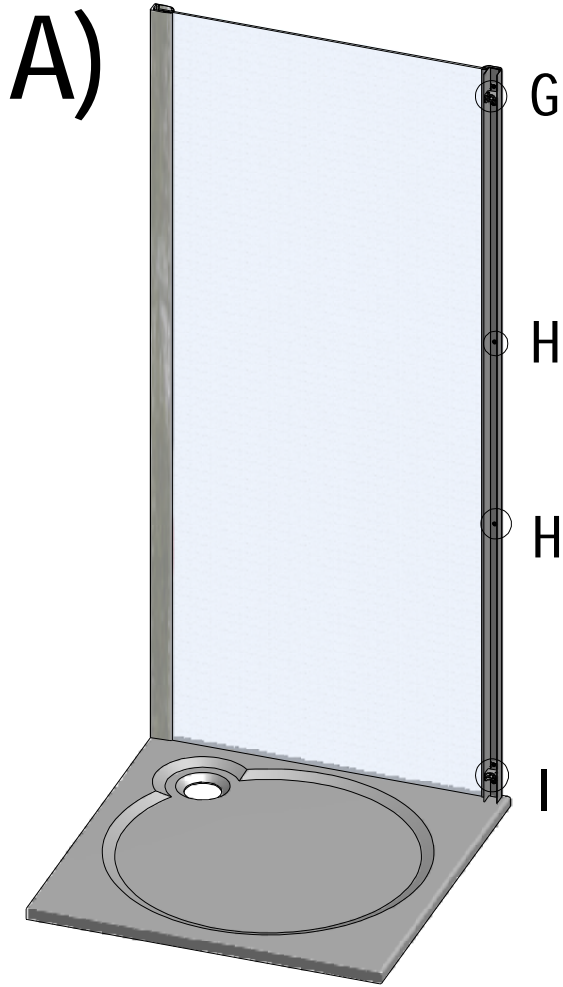

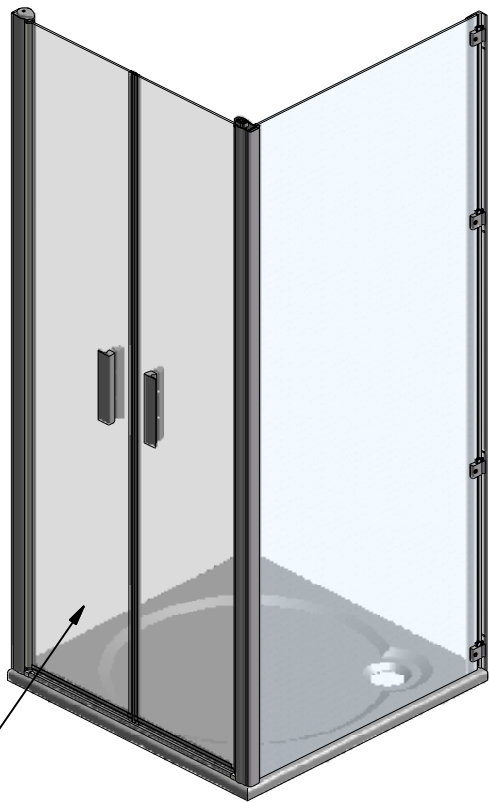

instruction manual TCN2



J2

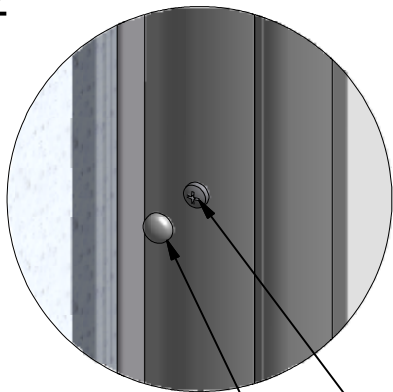

26 manual TCN2

27 manual TCN2

J1

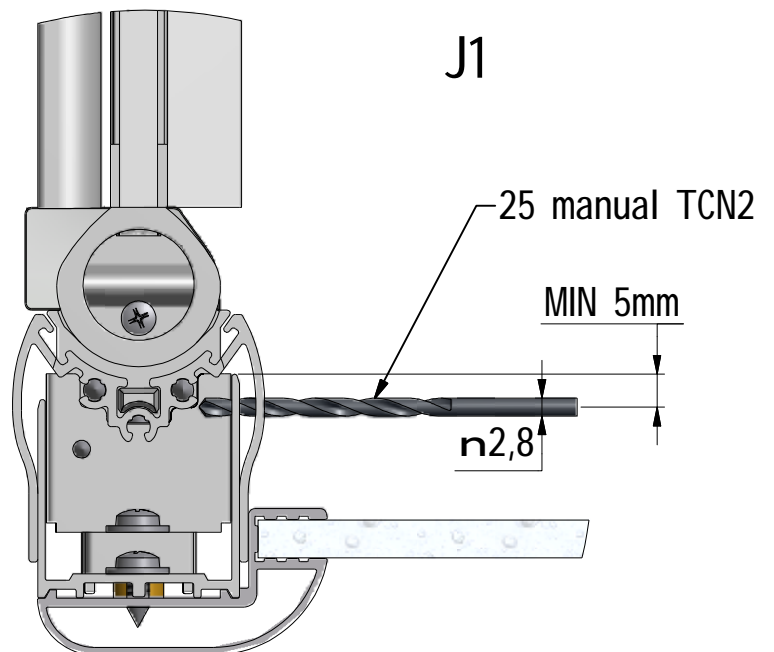



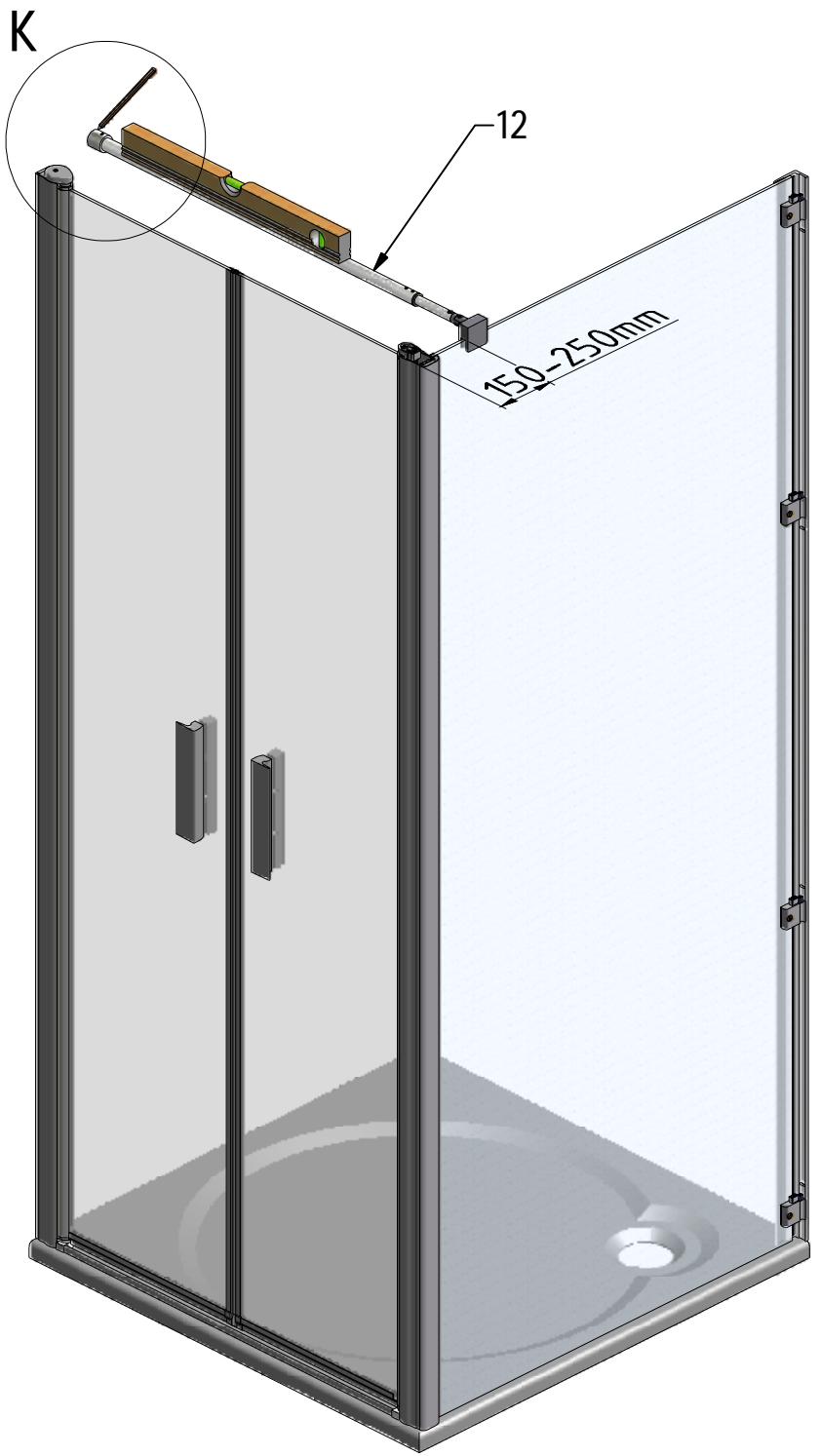

K1

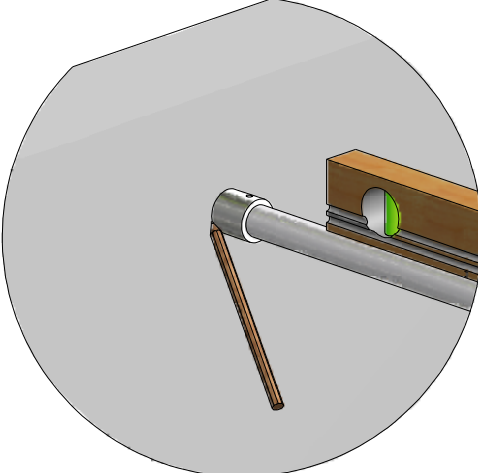

K2

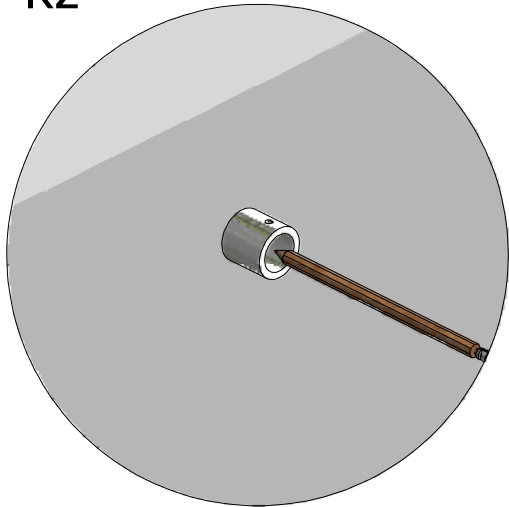

K4

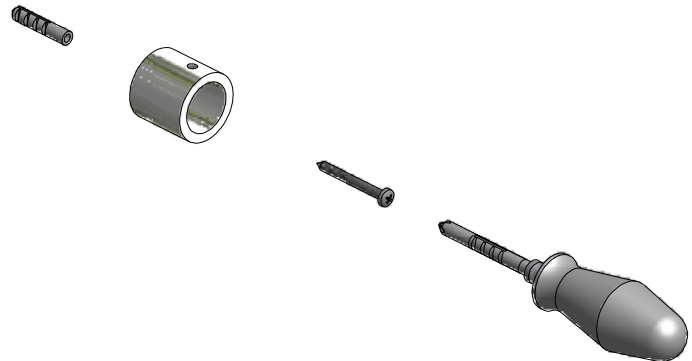

K3

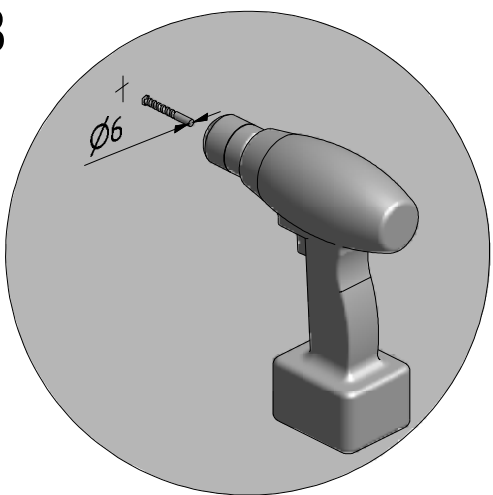



K5

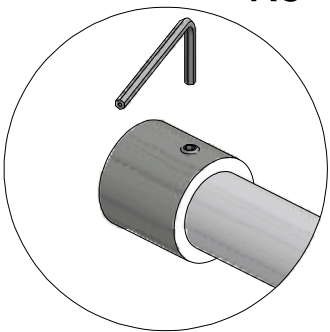

K6

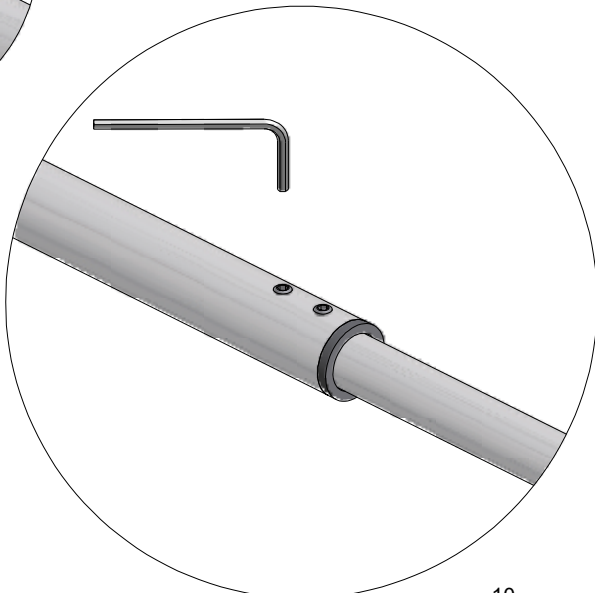

K7

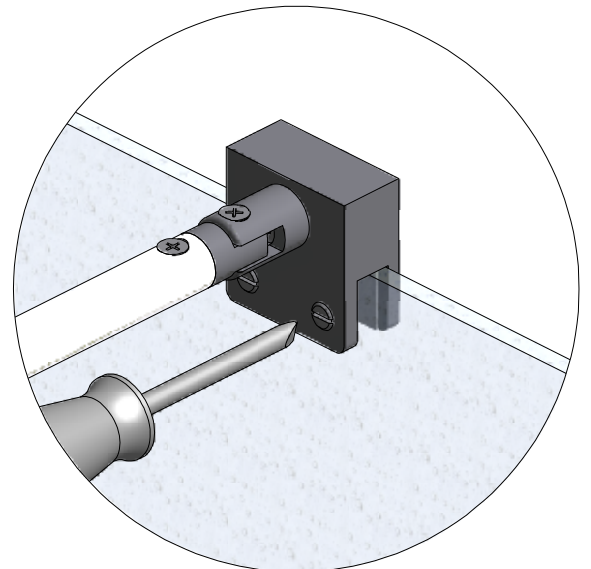

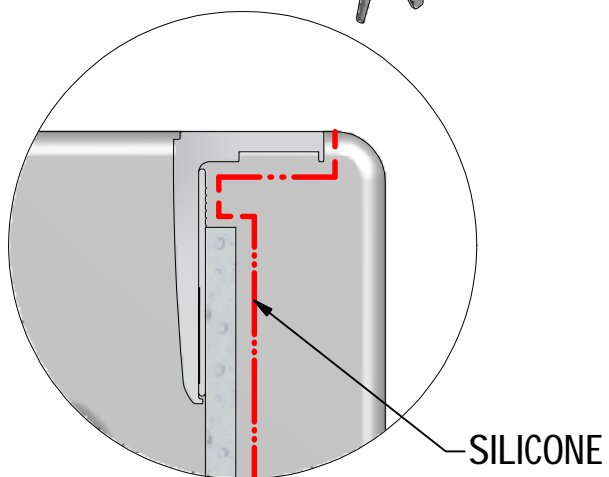
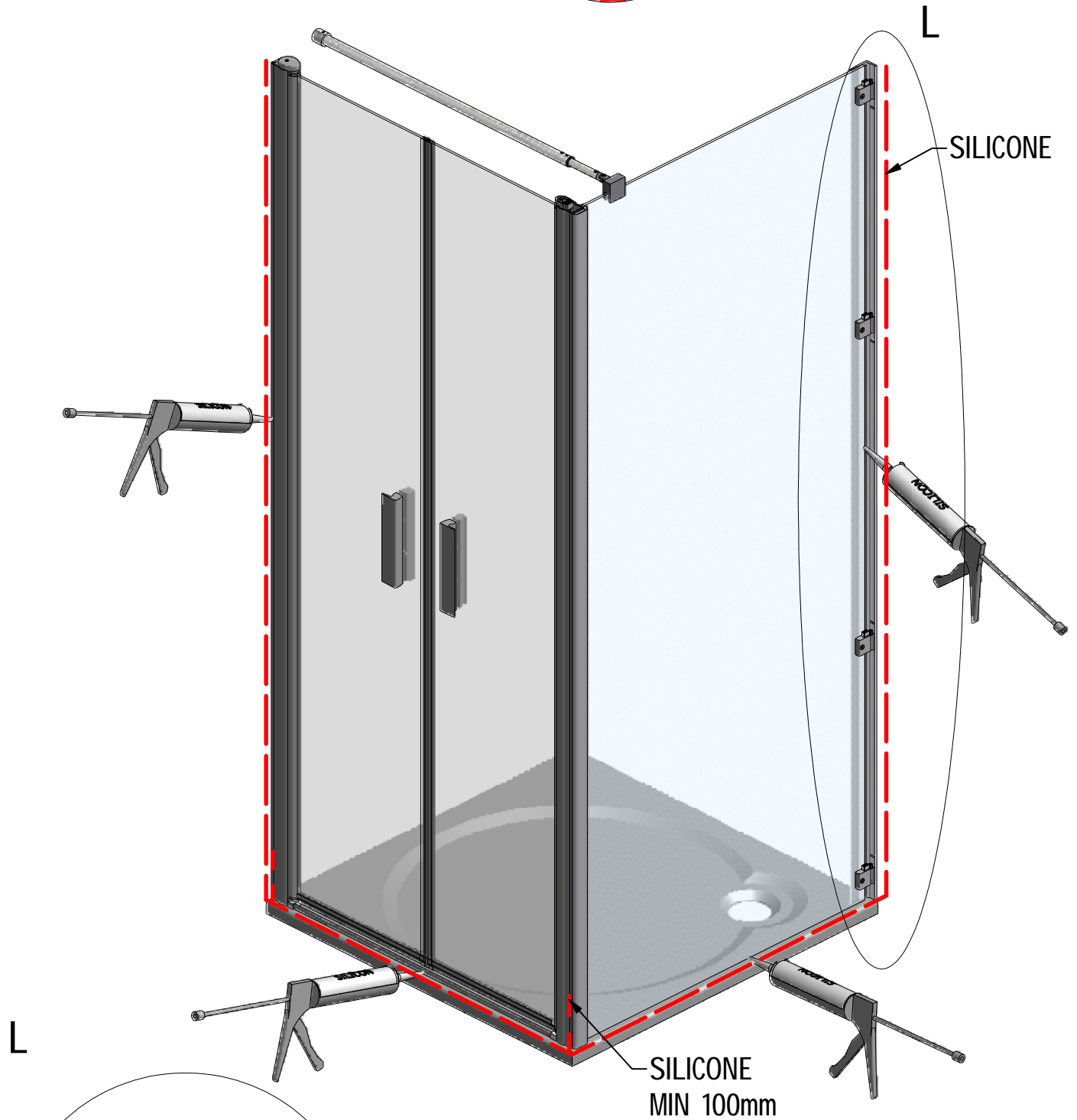

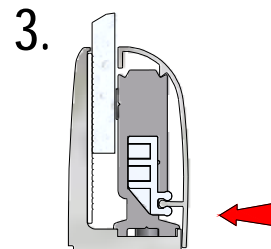
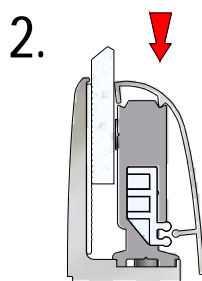
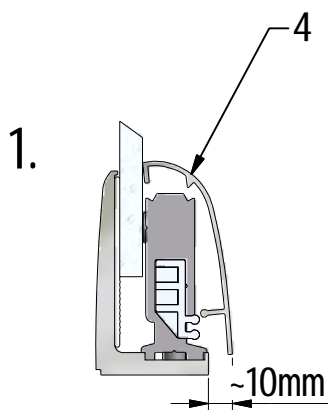
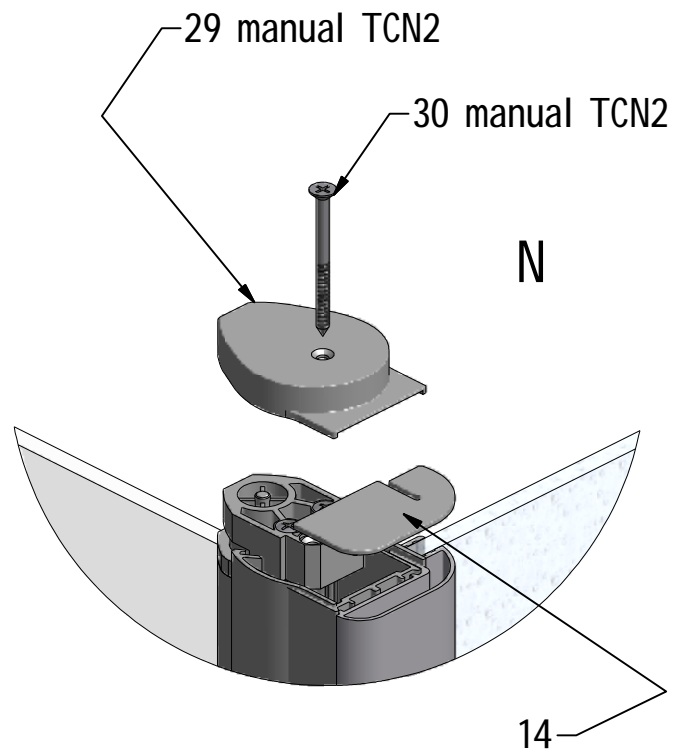
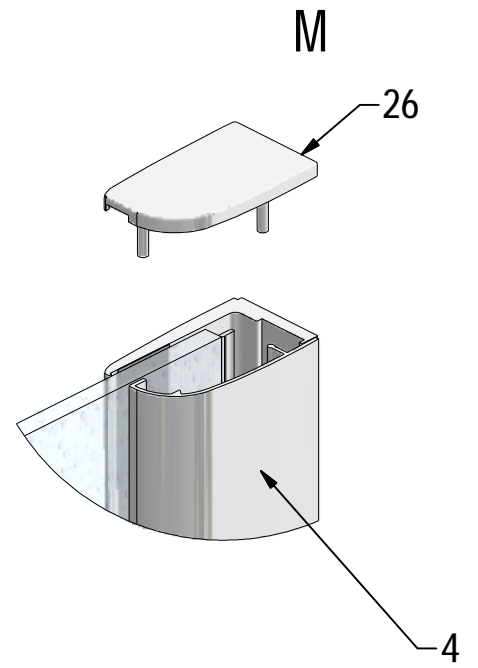

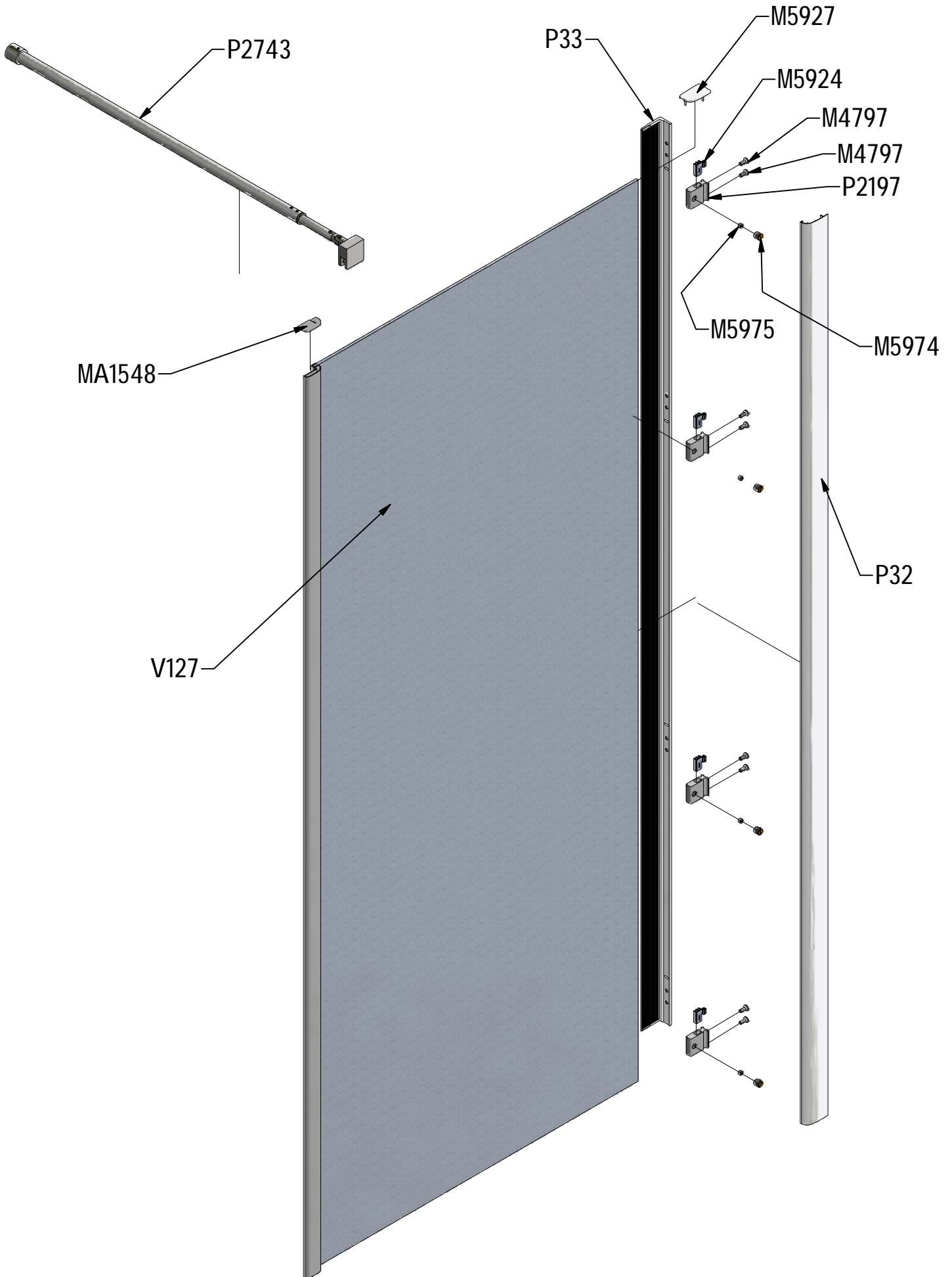

V127	800	clear glass+brillant	ND03-0662-00-02
		clear glass+elox	ND03-0662-01-02
	900	clear glass+brillant	ND03-0663-00-02
		clear glass+elox	ND03-0663-01-02
	1000	clear glass+brillant	ND03-0664-00-02
		clear glass+elox	ND03-0664-01-02

P32		brilant	P2197
		elox	P2205

P33		brilant	ND01-0973-00
		elox	ND01-0973-01