

DE	Gebrauchsanleitung / Montageanleitung	2
FR	Mode d'emploi / Instructions de montage	2
EN	Instructions for use / assembly instructions	3
IT	Istruzioni per l'uso / Istruzioni per Installazione	3
ES	Modo de empleo / Instrucciones de montaje	4
NL	Gebruiksaanwijzing / Handleiding	4
DK	Brugsanvisning / Monteringsvejledning	5
PT	Instruções para uso / Manual de Instalação	5
PL	Instrukcja obsługi / Instrukcja montażu	6
CS	Návod k použití / Montážní návod	6
SK	Návod na použitie / Montážny návod	7
ZH	用户手册 / 组装说明	7
RU	Руководство пользователя / Инструкция по монтажу	8
HU	Használati útmutató / Szerelési útmutató	8
FI	Käyttöohje / Asennusohje	9
SV	Bruksanvisning / Monteringsanvisning	9
LT	Vartotojo instrukcija / Montavimo instrukcijos	10
HR	Upute za uporabu / Uputstva za instalaciju	10
TR	Kullanım kılavuzu / Montaj kılavuzu	11
RO	Manual de utilizare / Instrucțiuni de montare	11
EL	Οδηγίες χρήσης / Οδηγία συναρμολόγησης	12
SI	Navodilo za uporabo / Navodila za montažo	12
ET	Kasutusjuhend / Paigaldusjuhend	13
LV	Lietošanas pamācība / Montāžas instrukcija	13
SR	Uputstvo za upotrebu / Uputstvo za montažu	14
NO	Bruksanvisning / Montasjeveiledning	14
BG	Инструкция за употреба / Инструкция за употреба	15
SQ	Udhëzuesi i përdorimit / Udhëzime rreth montimit	15
AR	دليل الاستخدام / تعليمات التجميع	16

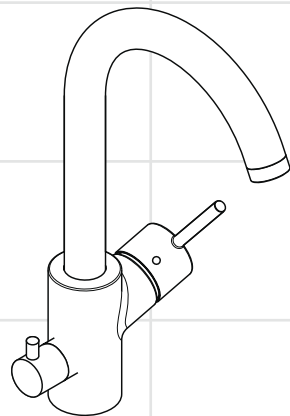

Talis S² Variarc
14875XXX

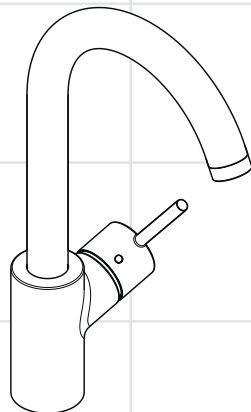

Talis S² Variarc
14870XXX



Sicherheitshinweise

- △ Bei der Montage müssen zur Vermeidung von Quetsch- und Schnittverletzungen Handschuhe getragen werden.
- △ Große Druckunterschiede zwischen den Kalt- und Warmwasseranschlüssen müssen ausgeglichen werden.
- △ **14875XXX:** Nur Spül- oder Waschmaschinen die das DVGW-Zeichen führen, dürfen ohne Zusatzsicherung an das Geräteanschlussventil angeschlossen werden. Wird kein Verbraucher an das Geräteanschlussventil angeschlossen, muss dieses abgestopft werden.

Montagehinweise

- Die Armatur muss nach den gültigen Normen montiert, gespült und geprüft werden!

Technische Daten

Betriebsdruck:	max. 1 MPa
Empfohlener Betriebsdruck:	0,1 - 0,5 MPa
Prüfdruck:	1,6 MPa
(1 MPa = 10 bar = 147 PSI)	
Heißwassertemperatur:	max. 80 °C
Empfohlene Heißwassertemperatur:	65 °C
Durchflussleistung bei 0,3 MPa:	10 l/min

Hansgrohe Armaturen können in Verbindung mit hydraulisch und thermisch gesteuerten Durchlauferhitzern eingesetzt werden wenn der Fließdruck mindestens 0,15 MPa beträgt.



Einhandmischer mit Warmwasserbegrenzung, Justierung siehe Seite 23. In Verbindung mit Durchlauferhitzern ist eine Warmwassersperre nicht notwendig.

Consignes de sécurité

- △ Lors du montage, porter des gants de protection pour éviter toute blessure par écrasement ou coupure
- △ Il est conseillé d'équilibrer les pressions de l'eau chaude et froide.
- △ Seuls les lave-vaisselle ou machines à laver portant le sigle DVGW, doivent être reliés sans fusible supplémentaire au raccord de l'appareil. Si aucun consommateur n'est relié à la valve-raccord de l'appareil, cette dernière doit être obturée.

Instructions pour le montage

- La robinetterie doit être installée, rincée et contrôlée conformément aux normes valables!

Informations techniques

Pression de service autorisée:	max. 1 MPa
Pression de service conseillée:	0,1 - 0,5 MPa
Pression maximum de contrôle:	1,6 MPa
(1 MPa = 10 bar = 147 PSI)	
Température d'eau chaude:	max. 80 °C
Température recommandée:	65 °C
Débit à 0,3 MPa:	10 l/min

Les mitigeurs Hansgrohe fonctionnent également en association à des chauffe-eau à commande hydraulique ou thermique à condition que la pression soit au minimum de 0,15 MPa.



Mitigeur avec limitation de la température: consulter la page 23 pour le réglage. Une limitation de la température n'est pas nécessaire quand le mitigeur est alimenté par un chauffe-eau instantané.



Kein essigsäurehaltiges Silikon verwenden!



Ne pas utiliser de silicone contenant de l'acide acétique!



Maße (siehe Seite 20)



Dimensions (voir page 20)



Serviceteile (siehe Seite 22)



Pièces détachées (voir pages 22)



Bedienung (siehe Seite 21)



Instructions de service (voir page 21)



Reinigung
siehe beiliegende Broschüre





Nettoyage
voir la brochure ci-jointe.





Safety Notes

-  Gloves should be worn during installation to prevent crushing and cutting injuries.
-  The hot and cold supplies must be of equal pressures.
-  Only dishwashers and washing machines certified with the DVGW emblem may be connected to the appliance connection valve without an additional fuse. If no consumer is connected to the appliance connection valve, it must be plugged.

Installation Instructions

- The fitting must be installed, flushed and tested after the valid norms!

Technical Data

Operating pressure:	max. 1 MPa
Recommended operating pressure:	0,1 - 0,5 MPa
Test pressure:	1,6 MPa
(1 MPa = 10 bar = 147 PSI)	
Hot water temperature:	max. 80 °C
Recommended hot water temp.:	65 °C
Rate of flow by 0,3 MPa:	10 l/min

Hansgrohe mixers can be used together with hydraulically and thermally controlled continuous flow heaters if the flow pressure is at least 0,15 MPa.



To adjust the hot water limiter on single lever mixers, please see page 23. No adjustment is necessary when using a continuous flow water heater.



Do not use silicone containing acetic acid!



Dimensions (see page 20)



Spare parts (see page 22)





Operation (see page 21)



Cleaning see enclosed brochure.

Indicazioni sulla sicurezza

-  Durante il montaggio, per evitare ferite da schiacciamento e da taglio bisogna indossare guanti protettivi.
-  Attenzione! Compensare le differenze di pressione tra i collegamenti dell'acqua fredda e dell'acqua calda.
-  Solo le lavastoviglie e lavatrici con il marchio DVGW si possono collegare senza fusibile supplementare con la valvola di collegamento dell'apparecchio. Nel caso in cui non si collega un apparecchio con la valvola di collegamento, la valvola deve essere chiusa con l'apposito tappo.

Istruzioni per il montaggio

- La rubinetteria deve essere installata, pulita e testata secondo le istruzioni riportate!

Dati tecnici

Pressione d'uso:	max. 1 MPa
Pressione d'uso consigliata:	0,1 - 0,5 MPa
Pressione di prova:	1,6 MPa
(1 MPa = 10 bar = 147 PSI)	
Temperatura dell'acqua calda:	max. 80 °C
Temp. dell'acqua calda consigliata:	65 °C
Potenza di erogazione a 0,3 MPa:	10 l/min

I miscelatori Hansgrohe possono venire usati con caldaie a „bassa pressione“ se la pressione di flusso è almeno di 0,15 MPa.



Regolazione del limitatore di erogazione di acqua calda dei miscelatori monocomando, vedere pagina 23. In combinazione con le caldaie istantanee, il limitatore di erogazione di acqua calda non è necessario.



Non utilizzare silicone contenente acido acetico!



Ingombri (vedi pagg. 20)



Parti di ricambio (vedi pagg. 22)



Procedura (vedi pagg. 21)



Pulitura vedi il prospetto accluso.

Assembly
see page 17



Montaggio
vedi pagg. 17



Indicaciones de seguridad

- ⚠ Durante el montaje deben utilizarse guantes para evitar heridas por aplastamiento o corte.
- ⚠ Grandes diferencias de presión en servicio entre agua fría y agua caliente deben equilibrarse.
- ⚠ Sin seguro adicional, solo está permitido conectar a la válvula de conexión de aparatos, los lavavajillas y las lavadoras que lleven incorporado el sello DVGW (Asociación alemana de especialistas en instalaciones de gas y agua). Si no se va a conectar ningún dispositivo consumidor a la válvula de conexión de aparatos, entonces esta deberá taparse con prensaestopas.

Indicaciones para el montaje

- El grifo tiene que ser instalado, probado y testado, según las normas en vigor.

Datos técnicos

Presión en servicio:	max. 1 MPa
Presión recomendada en servicio:	0,1 - 0,5 MPa
Presión de prueba:	1,6 MPa
(1 MPa = 10 bar = 147 PSI)	
Temperatura del agua caliente:	max. 80 °C
Temp. recomendada del agua caliente:	65 °C
Caudal a 0,3 MPa:	10 l/min

Los mezcladores Hansgrohe pueden ser utilizados junto con calentadores continuos de agua que sean manejados de manera hidráulica o térmica, siempre que la presión en servicio ascienda a un mínimo de 0,15 MPa.



Uso como mezclador monomando con limitación del caudal de agua caliente: ver ajuste en página 23. En combinación con calentadores instantáneos no es necesario limitar el caudal de agua caliente.

Veiligheidsinstructies

- ⚠ Bij de montage moeten ter voorkoming van kniel- en snijwonden handschoenen worden gedragen.
- ⚠ Grote drukverschillen tussen de kouden warm wateraansluitingen dienen vermeden te worden.
- ⚠ Enkel vaatwas- of wasmachines die beschikken over het DVGW-kenmerk, mogen zonder extra beveiliging aangesloten worden aan de aansluitklep van het apparaat. Indien geen verbruiker aan de aansluitklep van het apparaat wordt aangesloten, moet die afgesloten worden.

Montage-instructies

- Leidingen doorspoelen volgens Norm. De mengkraan vervolgens monteren en controleren!

Technische gegevens

Werkdruk: max.	max. 1 MPa
Aanbevolen werkdruk:	0,1 - 0,5 MPa
Getest bij:	1,6 MPa
(1 MPa = 10 bar = 147 PSI)	
Temperatuur warm water:	max. 80 °C
Aanbevolen warm water temp.:	65 °C
Doorvoercapaciteit bij 0,3 MPa:	10 l/min

Hansgrohe kranen kunnen samen met hydraulisch en thermisch gestuurde geisers gebruikt worden indien de uitstroombdruk min. 0,15 MPa bedraagt.



Eéngreepsmengkranen met warmwaterbegrenzing, instelling zie blz. 23. In combinatie met geisers is een warmwaterbegrenzing niet noodzakelijk.



No utilizar silicona que contiene ácido acético!



Gebruik geen zuurhoudende silicone!

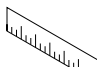

Dimensiones (ver página 20)



Maten (zie blz. 20)

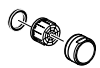

Repuestos (ver página 22)



Service onderdelen (zie blz. 22)



Manejo (ver página 21)



Bediening (zie blz. 21)

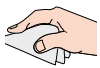

Limpiar ver el folleto adjunto.



Reinigen zie bijgevoegde brochure.



Montaje
ver página 17

Montage
zie blz. 17



Sikkerhedsanvisninger

- △ Ved monteringen skal der bruges handsker for at undgå kvæstelser og snitsår.
- △ Større trykforskelte mellem koldt og varmt vand bør udjævnes.
- △ Du må kun tilslutte opvaskemaskiner og vaske-maskiner med DVGW-tegn uden ekstra sikring til apparatets tilslutningsventil. Hvis der ikke tilsluttes en forbruger til apparatets tilslutningsventil, skal ventilen lukkes med en prop.

Monteringsanvisninger

- Ifølge gældende regler, skal armaturet monteres, skylles igennem og afprøves.

Tekniske data

Driftstryk:	max. 1 MPa
Anbefalet driftstryk:	0,1 - 0,5 MPa
Prøvetryk:	1,6 MPa
(1 MPa = 10 bar = 147 PSI)	
Varmtvandstemperatur:	max. 80 °C
Anbefalet varmtvandsstemperatur:	65 °C
Gennemstrømningsydelse ved 0,3 MPa:	10 l/min

Hansgrohe armaturer kan anvendes i forbindelse med hydraulisk- og termiskstyrede gennemstrømningsvandvarmere ved et vandtryk på 0,15 MPa.



Etgrebsarmaturer med varmtvandsbegrænsning, justering se side 23. I forbindelse med gennemstrømningsvandvarmere er en varmtvandsbegrænsning ikke nødvendig.



Der må ikke benyttes eddikesyreholdig silikone!

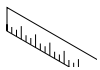

Målene (se s. 20)

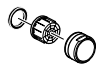

Reserve dele (se s. 22)



Brugsanvisning (se s. 21)

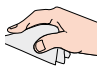

Rengøring
se venligst den vedlagte brochure.

Montering
se s. 17



Avisos de segurança

- △ Durante a montagem devem ser utilizadas luvas de protecção, de modo a evitar ferimentos resultantes de entalamentos e de cortes.
- △ Grandes diferenças entre as pressões das águas quente e fria devem ser compensadas.
- △ Apenas as máquinas de lavar loiça ou as máquinas de lavar roupa que têm a posto o símbolo DVGW podem ser conectadas à válvula de ligação do aparelho, sem a utilização de um dispositivo de protecção complementar. Se a válvula de ligação do aparelho não for conectada a nenhum consumidor é necessário fechá-la.

Avisos de montagem

- A misturadora deve ser instalada, purgada e testada de acordo com as normas em vigor!

Dados Técnicos

Pressão de funcionamento:	max. 1 MPa
Pressão de func. recomendada:	0,1 - 0,5 MPa
Pressão testada:	1,6 MPa
(1 MPa = 10 bar = 147 PSI)	
Temperatura da água quente:	max. 80 °C
Temp. água quente recomendada:	65 °C
Caudal o 0,3 MPa:	10 l/min

As misturadoras Hansgrohe podem ser utilizadas com esquentadores (de controlo térmico ou hidráulico) desde que a pressão de utilização seja, no mínimo, de 0,15 MPa.



Misturadora monocomando equipada com limitador de temperatura (vide pág.23). Em combinação com caldeira ou esquentador instantâneo o limitador de água quente não se aplica.



Não utilizar silicone que contenha ácido acético!



Medidas (ver página 20)



Peças de substituição (ver página 22)



Funcionamento (ver página 21)



Limpeza
consultar a seguinte brochura.

Montagem
ver página 17



! Wskazówki bezpieczeństwa

- △ Aby uniknąć zranień, takich jak zgniecenia czy przecięcia, podczas montażu należy nosić rękawice.
- △ Znaczne różnice ciśnień na dopływach ciepłej i zimnej wody muszą zostać wyrównane.
- △ Bez dodatkowego zabezpieczenia do zaworu przyłączeniowego urządzenia można podłączyć jedynie zmywarkę lub pralkę posiadającą znaczek DVGW. Gdy do zaworu przyłączeniowego urządzenia nie podłącza się żadnego odbiornika, należy go zaślepić.

Wskazówki montażowe

- Armatura musi być zamontowana, przepłukana i wypróbowana według obowiązujących norm!

Dane techniczne

Ciśnienie robocze:	maks. 1 MPa
Zalecane ciśnienie robocze:	0,1 - 0,5 MPa
Ciśnienie próbne:	1,6 MPa
(1 MPa = 10 bary = 147 PSI)	
Temperatura wody gorącej:	maks. 80 °C
Zalecana temperatura wody gorącej:	65 °C
Wydajność przepływu przy 0,3 MPa:	10 l/min

Armatura Hansgrohe może być stosowana z przepływowymi podgrzewaczami wody sterowanymi hydraulicznie i termicznie w przypadku, gdy ciśnienie przepływu wynosi co najmniej 0,15 MPa.



Mieszacz jednouchwytowy z ogranicznikiem temperatury wody, ustawianie, patrz str. 23. W połączeniu z przepływowym podgrzewaczem wody ogranicznik temperatury wody nie jest konieczny.



Nie stosować silikonów zawierających kwas octowy!



Wymiary (patrz strona 20)



Części serwisowe (patrz strona 22)



Obsługa (patrz strona 21)



Czyszczenie
patrz dołączona broszura.

! Bezpečnostní pokyny

- △ Pro zabránění řezným zraněním a pohmožděním je nutné při montáži nosit rukavice.
- △ Je nutné vyrovnat velké rozdíly tlaku mezi přípoji studené a teplé vody.
- △ Na ventil pro připojení zařízení se smí bez přídavné pojistky připojit jen myčky nebo pračky se značkou DVGW. Pokud nebude k připojovacímu ventilu napojen žádný spotřebič, je nutné ho opatřit záslepkou.

Pokyny k montáži

- Armatura se musí montovat, proplachovat a testovat podle platných norem!

Technické údaje

Provozní tlak:	max. 1 MPa
Doporučený provozní tlak:	0,1 - 0,5 MPa
Zkušební tlak:	1,6 MPa
(1 MPa = 10 bar = 147 PSI)	
Teplota horké vody:	max. 80 °C
Doporučená teplota horké vody:	65 °C
Průtokové množství při 0,3 MPa:	10 l/min

Armatury Hansgrohe je možno používat v kombinaci s hydraulicky a tepelně řízenými průtokovými ohřivači v případě, že tlak činí minimálně 0,15 MPa.



Páková baterie s omezením horké vody, seřízení viz. str. 23. Ve spojení s průtokovými ohřivači není uzávěr teplé vody nutný.



Nepoužívat silikon s obsahem kyseliny octové!



Rozměry (viz strona 20)



Servisní díly (viz strona 22)



Ovládání (viz strona 21)



Čištění viz příložená brožura.)





Bezpečnostné pokyny

- △ Pri montáži musíte nosiť rukavice, aby ste predišli pomliaždeninám a rezným poraneniam.
- △ Veľké rozdiely v tlaku medzi prípojkami studenej a teplej vody musia byť vyrovnané.
- △ K ventilu pripojenia zariadení je možné bez dodatočného zaistenia pripojiť len umýv ačku riadu alebo práčku so značkou DVGW. Ak nebude k pripojovaciemu ventilu pripojený žiaden spotrebič, musí byť tento opatrený záslepkou.

Pokyny pre montáž

- Batéria sa musí montovať, preplachovať a testovať podľa platných noriem!

Technické údaje

Prevádzkový tlak:	max. 1 MPa
Doporučený prevádzkový tlak:	0,1 - 0,5 MPa
Skúšobný tlak:	1,6 MPa
(1 MPa = 10 bar = 147 PSI)	
Teplota teplej vody:	max. 80 °C
Doporučená teplota teplej vody:	65 °C
Prietokové množstvo pri 0,3 MPa:	10 l/min

Batérie Hansgrohe môžete používať v spojení s hydraulickými a tepelne ovládanými prietokovými ohrievačmi, ak je tlak minimálne 0,15 MPa.



Páková batéria s obmedzením teplej vody, nastavenie viď.str. 23. V spojení s prietokovými ohrievačmi nie je uzáver teplej vody nutný.



Nepoužívať silikón s obsahom kyseliny octovej!



Rozmery (viď strana 20)



Servisné diely (viď strana 22)



Obsluha (viď strana 21)



Čištění nájdete v priloženej brožúre.

Montáž
viď strana 17



安全技巧

- △ 装配时为避免挤压和切割受伤，必须戴上手套。
- △ 冷热水管间过大的压力差必须予以平衡。
- △ 只有那些带有DVGW标记的洗衣机或洗碗机才可以不需附加其他安全设备而直接连接到本产品的外接设备供水阀上。用户不得连接本产品的外接设备供水阀，必须把它堵起来。

安装提示

- 必须按照现行的规定安装，冲洗和测试产品！

技术参数

工作压力:	最大 1 MPa
推荐工作压力:	0,1 - 0,5 MPa
测试压力:	1,6 MPa
(1 MPa = 10 bar = 147 PSI)	
热水温度:	最大 80 °C
推荐热水温度:	65 °C
流量 钟0,3 MPa:	10 升/分钟

如果水压达到0,15 MPa以上，汉斯格雅双手柄龙头可以和液压式或热控式连续流热水器一起使用。



带有热水控制器的单手柄龙头的调节方法，参见第23页。如果与连续流热水器一起使用，则不必作任何调节。



请勿使用含有乙酸的硅！



大小 (参见第 20 页)



备用零件 (参见第22页)



操作 (参见第 21 页)





清洗 附有小手册

安装
参见第17页



Указания по технике безопасности

-  Во время монтажа следует надеть перчатки во избежание прищемления и порезов.
-  донного клапа. Перед установкой смесителя необходимо регулировочными кранами выровнять авление холодной и горячей воды при помощи вентилей регулирующих подачу воды в квартиру.
-  Без дополнительного предохранителя к вентилю для подключения приборов разрешается подключать только посудомоечные или стиральные машины со знаком DVGW. Если к вентилю для подключения приборов не подключено ни одного приемника, то его необходимо закрыть.

Указания по монтажу

- Смеситель должен быть смонтирован по действующим нормам и в соответствии с настоящей инструкцией, проверен на геметичность и безупречность работы

Технические данные

Рабочее давление: не более. 1 МПа
 Рекомендуемое рабочее давление: 0,1 - 0,5 МПа
 Давления: 1,6 МПа
 (1 МПа = 10 bar = 147 PSI)
 Температура горячей воды: не более. 80 °C
 Рекомендуемая темп. гор. воды: 65 °C
 Расход при 0,3 МПа: 10 л/мин
 Арматуры Hansgrohe могут использоваться в комбинации с проточными нагревателями с гидравлическим и термическим управлением, если давление истечения составляет не менее 0,15 МПа.



Однорычажный смеситель имеет ограничитель расхода горячей воды (см. Стр. 23: юстировка).



Не применяйте силикон, содержащий уксусную кислоту.



Размеры (см. стр. 20)



Комплект (см. стр. 22)





Эксплуатация (см. стр. 21)



Очистка
см прилагаемая брошюра

Biztonsági utasítások

-  A szerelésnél a zúródások és vágási sérülések elkerülése érdekében kesztyűt kell viselni.
-  A hidegvíz- és a melegvíz-csatlakozások közötti nagy nyomáskülönbséget kikell egyenlíteni!
-  Csak a DVGW-jelzéssel ellátott mosogató- vagy mosógépeket szabad kiegészítő biztosítás nélkül a készülék csatlakozószelepéhez csatlakoztatni. Amennyiben nem csatlakoztatnak felhasznált a készülék csatlakozószelepéhez, akkor ezt be kell dugaszolni.

Szerelési utasítások

- A csaptelepelt az érvényben lévő előírásoknak megfelelően kell felszerelni, átöblíteni és ellenőrizni!

Műszaki adatok

Üzemi nyomás: max. 1 МПа
 Ajánlott üzemi nyomás: 0,1 - 0,5 МПа
 Nyomáspróba: 1,6 МПа
 (1 МПа = 10 bar = 147 PSI)
 Forróvíz hőmérséklet: max. 80 °C
 Forróvíz javasolt hőmérséklete: 65 °C
 Átfolyási teljesítmény 0,3 МПа: 10 l/perc

A Hansgrohe csaptelepelt hidraulikus és termikus vezérlésű átfolyós melegítővel kapcsolatban is használhatóak, ha az átfolyó nyomás legalább 0,15 МПа.



Az egykaros, melegvíz-korlátozóval ellátott keverő csaptelep beállítását lásd a 23. oldalon. Az átfolyó rendszerű vízmelegítőknél nem szükséges a melegvíz-korlátozó.



Ne használjon ecetsavtartalmú szilikon!



Méretet (lásd a 20. oldalon)



Tartozékok (lásd a 22. oldalon)



Használat (lásd a 21. oldalon)





Tisztítás lásd a mellékelt broszúrát.





Turvallisuusohjeet

-  Asennuksessa on käytettävä käsineitä puristumien ja viiltojen aiheuttamien tapaturmien estämiseksi.
-  Suuret paine-erot kylmä- ja kuumavesiliitäntöjen välillä on tasattava.
-  Vain sellaiset astian- tai pyykinpesukoneet, joissa on DVGW-merkintä, saa kytkeä ilman lisävarmistusta laiteliittimeen. Jos liitäntäventtiiliin ei liitetä konetta, se on tukittava.

Asennusohjeet

- Kaluste on asennettava, huuhdeltava ja tarkastettava voimassa olevien määräysten mukaisesti!

Tekniset tiedot



Käyttöpaine:	maks. 1 MPa
Suosittelut käyttöpaine:	0,1 - 0,5 MPa
Koestuspaine:	1,6 MPa
(1 MPa = 10 bar = 147 PSI)	
Kuuman veden lämpötila:	maks. 80 °C
Kuuman veden suosituslämpötila:	65 °C
Läpivirtausmäärä 0,3 MPa paineella:	10 l/min

Hansgrohe kalusteita voi käyttää hydraulisesti tai termisesti ohjattujen läpivirtauskuumentimien yhteydessä, jos virtauspaine on vähintään 0,15 MPa.



Yksivipuinen sekoittaja lämpimän veden rajoituksella, katso säätö sivulta 23. Lämpimän veden rajoitusta ei tarvita läpivirtauskuumentimen yhteydessä.

Säkerhetsanvisningar

-  Handskar ska bäras under monteringsarbetet så att man kan undvika kläm- och skärskadorgen werden.
-  Stora tryckskillnader mellan anslutningarna för varmt och kallt vatten måste utjämnas.
-  Endast disk- och tvättmaskiner som är försedda med DVGW-märkning får anslutas till kopplingsventilen utan extra uppsäkring. Om ingen förbrukare ansluts till kopplingsventilen måste denna sättas igen.

Monteringsanvisningar

- Blandaren måste installeras, genomspolas och testas enligt gällande föreskrifter.

Tekniska data

Driftstryck:	max. 1 MPa
Rek. driftstryck:	0,1 - 0,5 MPa
Tryck vid provtryckning:	1,6 MPa
(1 MPa = 10 bar = 147 PSI)	
Varmvattentemperatur:	max. 80 °C
Rek. varmvattentemp.:	65 °C
Flödeskapacitet vid 0,3 MPa:	10 l/min

Hansgrohe blandare kan användas tillsammans med hydrauliskt och termiskt styrda varmvattenberedare när flödestrycket uppgår till minst 0,15 MPa.



Enhandsblandare med varmvattenreglering, justering se sidan 23. Vid användning tillsammans med varmvattenberedare behövs ingen varmvattenreglering.



Älä käytä etikkahappoitoista silikonia!



Använd inte silikon som innehåller ättiksyra!

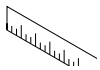

Mitat (katso sivu 20)



Måtten (se sidan 20)

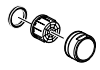

Varaosat (katso sivu 22)



Reservdelar (se sidan 22)

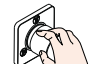

Käyttö (katso sivu 21)



Hantering (se sidan 21)



Puhdistus katso oheinen esite



Rengöring se den medföljande broschyren

Asennus
katso sivu 17



Montering
se sidan 17



Saugumo technikos nurodymai

- △ Apsaugai nuo užspaudimo ir įsijpavimo montavimo metu mūvėkite pirštines.
- △ Turi būti išlyginti šalto ir karšto slėgio nelygumai.
- △ Be papildomos apsaugos prie įrenginio jungiamojo vožtuvo junkkite tik skalbimo arba indų plovimo mašinas, turinčias DVGW ženklą. Jeigu prie įrenginio prijungimo vožtuvo neprijungtas joks prietaisas, jis turi būti sandariai uždarytas.

Montavimo instrukcija

- Maišytuvas privalo būti montuojamas, išleidžiamas ir patikrinamas pagal galiojančias normas!

Techniniai duomenys

Darbinis slėgis: ne daugiau kaip 1 MPa
 Rekomenduojamas slėgis: 0,1 - 0,5 MPa
 Bandomasis slėgis: 1,6 MPa
 (1 MPa = 10 barų = 147 PSI)
 Karšto vandens temperatūra: ne daugiau kaip 80 °C
 Rekomenduojama karšto vandens temperatūra: 65 °C
 Vandens pralaidumas, esant 0,3 MPa slėgiui: 10 l/min

„Hansgrohe“ maišytuvai gali būti naudojami su hidrauliškai ir termiškai reguliuojamais momentiniais šildikliais, kai vandens slėgis mažesnis kaip 0,15 MPa.



Vienos rankenėlės maišytuvai turi karšto vandens ribotuvą (nustatymą žr. psl. 23). Naudojant momentinį šildiklį karšto vandens ribotuvus nebūtinai.

Sigurnosne upute

- △ Prilikom montaze se radi sprječavanja prignječenja i posjekotina moraju nositi rukavice.
- △ Velika razlika u pritisku između vruće i hladne vode mora biti izbalansirana.
- △ Samo perlice za suđe ili rublje sa oznakom DVGW smijete koristiti bez dodatnog osiguranja priključnog ventila! Ako se na priključni ventil uređaja ne priključuje niti jedan potrošač, isti se mora začepiti.

Upute za montažu

- Cijevi moraju biti postavljene, isprane i testirane prema važećim normama!

Tehnički podatci

Najveći dopušteni tlak: tlak 1 MPa
 Preporučeni tlak: 0,1 - 0,5 MPa
 Probnii tlak: 1,6 MPa
 (1 MPa = 10 bar = 147 PSI)
 Temperatura vruće vode: tlak 80 °C
 Preporučena temperatura vruće vode: 65 °C
 Protok vode uz tlak od 0,3 MPa: 10 l/min

Hansgrohe armature mogu se koristiti u kombinaciji sa hidraulički i termički kontroliranim protočnim bojlerima ukoliko tlak iznosi najmanje 0,15 MPa



Da bi podesili limiter vruće vode na jednoručnim slavinama molimo Vas da pogledate stranicu 23. Podešavanje nije potrebno ako koristite protočni boiler.



Nenaudokite silikono, kurio sudėtyje yra acto rūgšties!



Nemojite koristiti silikon koji sadrži octenu kiselinu!



Išmatavimai (žr. psl. 20)



Mjere (pogledaj stranicu 20)



Atsarginės dalys (žr. psl. 22)



Rezervni djelovi (pogledaj stranicu 22)



Eksploatacija (žr. psl. 21)



Upotreba (pogledaj stranicu 21)



Valymas
žr. pridedamoje brošiūroje.



Čišćenje se u priloženoj brošuri.



Sastavljanje
pogledaj stranicu 17



! Güvenlik uyarıları

- Montaj esnasında ezilme ve kesilme gibi yaralanmaları önlemek için eldiven kullanılmalıdır.
- Sıcak ve soğuk su bağlantıları arasında büyük basınç farklılıkları varsa, bu basınç farklılıklarının dengelenmesi gerekir.
- Sadece DVGW işaretine sahip bulaşık ya da çamaşır makineleri ek emniyet olmadan cihaz bağlantı valfine bağlanmalıdır. Cihaz bağlantı valfine bir tüketici bağlanmayacaksa, bunun tapa ile kapatılması gerekir.

Montaj açıklamaları

- Batarya geçerli normlara göre monte edilmeli, yıkanmalı ve kontrol edilmelidir!

Teknik bilgiler

İşletme basıncı:	azami 1 MPa
Tavsiye edilen işletme basıncı:	0,1 - 0,5 MPa
Kontrol basıncı:	1,6 MPa
(1 MPa = 10 bar = 147 PSI)	
Sıcak su sıcaklığı:	azami 80 °C
Tavsiye edilen su ısısı:	65 °C
0,3 MPa'daki debi:	10 l/dak

Hansgrohe bataryaları, akış basıncı en az 0,15 MPa olursa hidrolik ve termik kumandalı şofbenlerle bağlantılı olarak kullanılabilir.



Sıcak su sınırlayıcı özelliğine sahip tek kollu bataryanın ayarlanması için 23. sayfaya bakınız. Bir sürekli akışlı su ısıtıcısı ile birlikte kullanılırsa sıcak su sınırlayıcısına gerek kalmaz.

! Instrucțiuni de siguranță

- La montare utilizați mănuși pentru evitarea contuziunilor și tăierii mâinilor.
- Diferențele de presiune mari între alimentarea cu apă rece și apă caldă trebuie echilibrate.
- Conectați numai mașinile de spălat sau mașinile de spălat vase fără siguranță adițională la ventilul de conectare a aparatului, care sunt marcate cu simbolul DVGW. Dacă la ventilul de conectare a aparatului nu conectați nici un consumator, acesta trebuie închis.

Instrucțiuni de montare

- Bateria trebuie montată, clătită și verificată conform normelor în vigoare.

Date tehnice

Presiune de funcționare:	max. 1 MPa
Presiune de funcționare recomandată:	0,1 - 0,5 MPa
Presiune de verificare:	1,6 MPa
(1 MPa = 10 bar = 147 PSI)	
Temperatura apei calde:	max. 80 °C
Temperatura recomandată a apei calde:	65 °C
Debit de apă la 0,3 MPa:	10 l/min

Bateriile Hansgrohe pot fi utilizate cu boiler instant cu comandă termică sau hidraulică dacă presiunea apei de alimentare este de min. 0,15 MPa.



Bateria monocomadă cu limitarea apei calde, pentru reglare vezi pag. 23. Dacă conectați bateria la un boiler instant nu este necesară instalarea unui opritor de apă caldă.



Asetik asit içeren silikon kullanmayın!



Nu utilizați silicon cu conținut de acid acetic!



Ölçüleri (Bakınız sayfa 20)



Dimensiuni (vezi pag. 20)



Yedek Parçalar (Bakınız sayfa 22)



Piese de schimb (vezi pag. 22)



Kullanımı (Bakınız sayfa 21)



Utilizare (vezi pag. 21)



Temizleme birlikte verilen broşür



Curățare vezi broșura alăturată.

Montajı
Bakınız sayfa 17



Montare
vezi pag. 17



Υποδειξεις ασφαλείας

- ▲ Για να αποφύγετε τραυματισμούς κατά τη συναρμολόγηση πρέπει να φοράτε γάντια.
- ▲ Οι διαφορές της πίεσης μεταξύ της σύνδεσης κρύου και ζεστού νερού θα πρέπει να αντισταθμίζονται.
- ▲ Μόνο πλυντήρια πιάτων ή πλυντήρια ρούχων που φέρουν το σήμα DVGW επιτρέπεται να συνδεθούν στη βαλβίδα σύνδεσης της συσκευής χωρίς πρόσθετη ασφάλεια. Αν δεν συνδεθεί κάποιος καταναλωτής στη βαλβίδα σύνδεσης της συσκευής, ταπώστε τη βαλβίδα.

Οδηγίες συναρμολόγησης

- Η κεντρική βάνα πρέπει να τοποθετηθεί, να πλυθεί και να ελεγχθεί με βάση τους ισχύοντες κανόνες υδραυλικής τέχνης!

Τεχνικά Χαρακτηριστικά

Λειτουργία πίεσης:	έως 1 MPa
Συνιστώμενη λειτουργία πίεσης:	0,1 - 0,5 MPa
Πίεση ελέγχου:	1,6 MPa (1 MPa = 10 bar = 147 PSI)
Θερμοκρασία ζεστού νερού:	έως 80 °C
Συνιστώμενη θερμοκρασία ζεστού νερού:	65 °C
Κατανάλωση νερού στα 0,3 MPa:	10 l/min

Οι βάνες Hansgrohe μπορούν να συνδυαστούν με ταχυθερμοσίφωνες υδραυλικού και θερμικού ελέγχου, όταν η πίεση ροής αριθμεί τουλάχιστον 0,15 MPa.



Για να προσαρμόσετε το δοσομετρική ζεστού νερού σε αναμεικτικές μπαταρίες, παρακαλούμε δείτε τη ρύθμιση στη σελ. 23. Δεν είναι απαραίτητη η διάταξη φραγής ζεστού νερού σε συνδυασμό με ταχυθερμοσίφωνα.



Μην χρησιμοποιείτε σιλικόνη που περιέχει οξικό οξύ!



Διαστάσεις (βλ. σελίδα 20)



Ανταλλακτικά (βλ. σελίδα 22)



Χειρισμός (βλ. σελίδα 21)



Καθαρισμός
βλ. συνημμένο φυλλάδιο

Varnostna opozorila

- ▲ Pri montaži je treba nositi rokavice, da se preprečijo poškodbe zaradi zmečkanja ali urezov.
- ▲ Velike razlike v tlaku med priključkom za mrzlo in priključkom za toplo vodo je potrebno izravnati.
- ▲ Na priključni ventil priprave se smejo brez dodatne zaščite priklopiti le pomivalni ali pralni stroji z znakom kakovosti DVGW. Če se na priključni ventil priprave ne priklopi nobenega porabnika, je treba ventil zamašiti.

Navodila za montažo

- La robinetterie doit être installée, rincée et contrôlée conformément aux normes valables!

Tehnični podatki

Delovni tlak:	maks. 1 MPa
Priporočeni delovni tlak:	0,1 - 0,5 MPa
Preskusni tlak:	1,6 MPa (1 MPa = 10 bar = 147 PSI)
Temperatura tople vode:	maks. 80 °C
Priporočena temperatura tople vode:	65 °C
Pretok vode pri 0,3 MPa:	10 l/min

Armature Hansgrohe lahko uporabljate v povezavi s hidravlično in termično uravnanimi pretočnimi grelniki, če je pretočni tlak najmanj 0,15 MPa.



Enoročne mešalne baterije z omejevalnikom tople vode, za justiranje glejte stran 23. V povezavi s pretočnimi grelniki zapora tople vode ni potrebna.



Ne smete uporabiti silikona, ki vsebuje ocetno kislino!



Mere (glejte stran 20)



Rezervni deli (glejte stran 22)



Upravljanje (glejte stran 21)





Čiščenje glejte priloženi brošuri.



Montaža
Glejte stran 17.



Ohutusjuhised

-  Kandke paigaldamisel muljumis- ja löikevigastuste vältimiseks kindaid.
-  Kui külma ja kuuma vee ühenduste surve on väga erinev, tuleb need tasakaalustada.
-  Seadme ühendusklapiga võib ühendada ainult DVGW-tähisega nõudepesu- või pesumasina. Kui seadme ühendusklapiga ei ühendata ühtki tarbijat, tuleb see sulgeda.

Paigaldamisjuhised

- Segisti paigaldamine, loputamine ja kontroll peab toimuma vastavalt kehtivatele normidele!

Tehnilised andmed

Töörõhk	maks. 1 MPa
Soovitavat töörõhki:	0,1 - 0,5 MPa
Kontrollsurve:	1,6 MPa
(1 MPa = 10 baari = 147 PSI)	
Kuuma vee temperatuur:	maks. 80 °C
Soovitavat kuuma vee temperatuur:	65 °C
Läbivool, kui rõhk on 0,3 MPa:	10 l/min

Hansgrohe segisteid võib kasutada koos hüdrauliliselt ja termiliselt juhitavate boileritega, kui vee surve on vähemalt 0,15 MPa.



Ühe juhtkangiga segisti kuuma vee piiraja reguleerimise kohta vt lk 23. Läbivoolu boilerite puhul pole reguleerimine vajalik.



Ärge kasutage äädikhapet sisaldavat silikooni!



Mõõtude (vt lk 20)



Varuosad (vt lk 22)





Kasutamine (vt lk 21)



Puhastamine
vt kaasasolevast brošüürist.

Paigaldamine
vt lk 17

Drošības norādes

-  Montāžas laikā, lai izvairītos no saspiedumiem un iegriezumiem, nepieciešams nēsāt cimdus.
-  Jāizlīdzina spiediena atšķirības starp aukstā un karstā ūdens pievadiem.
-  Ierīču pieslēgšanas vārstam drīkst pieslēgt bez papildus nodrošinājuma tikai tās trauku mazgājamās mašīnas un veļas mašīnas, kurām ir DVGW-zīme. Ja ierīču pieslēgšanas vārstam nav pieslēgta neviena ierīce, tas jāaizbīvē.

Norādījumi montāžai

- Armatūra jāuzstāda, jāizskalo un jāpārbauda atbilstoši spēkā esošajām normām!

Tehniskie dati

Darba spiediens:	maks. 1 MPa
Ieteicamais darba spiediens:	0,1 - 0,5 MPa
Pārbaudes spiediens:	1,6 MPa
(1 MPa = 10 bar = 147 PSI)	
Karstā ūdens temperatūra:	maks. 80 °C
Ieteicamā karstā ūdens temperatūra:	65 °C
Caurteces intensitāte pie 0,3 MPa:	10 l/min

Hansgrohe jaučējkārnus var izmantot kombinācijā ar hidrauliski un termiski vadāmiem caurteces sildītājiem, ja plūsmas spiediens ir vismaz 0,15 MPa.



Viensvires jaučējkārnus ar siltā ūdens ierobežošanu, ieregulēšanu skat. 23. lpp. Kombinācijā ar caurteces sildītāju karstā ūdens ierobežošana nav nepieciešama.



Neizmantojiet silikonu, kas satur etiķskābi!



Izmērus (skat. 20. lpp.)



Rezerves daļas (skat. 22. lpp.)



Lietošana (skat. 21. lpp.)





Tīrīšana
skatiet pievienotajā brošūrā.

Montāža
skat. 17. lpp.





Sigurnosne napomene

-  Prilikom montaže se radi sprečavanja prignječenja i posekotina moraju nositi rukavice.
-  Velika razlika u pritisku između vruće i hladne vode mora biti izbalansirana.
-  Samo mašine za veš ili suđe s oznakom DVGW se smeju priključivati bez dodatnog osiguranja priključnog ventila. Ako se na priključni ventil uređaja ne priključuje nijedan potrošač, isti se mora začepiti.

Instrukcije za montažu

- Armatura mora biti postavljena, isprana i testirana prema važećim normama!

Tehnički podaci

Radni pritisak:	maks. 1 MPa
Preporučeni radni pritisak:	0,1 - 0,5 MPa
Probni pritisak:	1,6 MPa
(1 MPa = 10 bar = 147 PSI)	
Temperatura vruće vode:	maks. 80 °C
Preporučena temperatura vruće vode:	65 °C
Protok vode pri pritisku od 0,3 MPa:	10 l/min

Hansgrohe armature se mogu koristiti u kombinaciji s hidraulički i termički kontrolisanim protočnim bojlerima ukoliko pritisak iznosi najmanje 0,15 MPa.



Da bi ste podesili ograničavač vruće vode na jednoručnim mešačima, molimo Vas da pogledate stranicu 23. Podešavanje nije potrebno ako koristite protočni bojljer.



Nemojte koristiti silikon koji sadrži sircetnu kiselinu!



Mere (vidi stranu 20)



Rezervni delovi (vidi stranu 22)





Rukovanje (vidi stranu 21)



Čišćenje vidi priloženoj brošuri.

Sikkerheshenvisninger

-  Bruk hansker under montasjen for å unngå klem- og kuttskader.
-  Store trykkdifferanser mellom kaldt- og varmtvannstilkoblinger skal utlignes. Kun oppvask- eller vaskemaskiner med DVGW merke kan kobles uten tilleggsstyring til ventilen for apparatetilkoblingen. Hvis ingen forbruker kobles til ventilen for apparatetilkoblingen, så skal ventilen tilstoppes.

Montagehenvisninger

- Armaturen skal monteres iht. gyldige standarder. De skal spyles og sjekkes!

Tekniske data

Driftstrykk	maks. 1 MPa
Anbefalt driftstrykk:	0,1 - 0,5 MPa
Prøvetrykk	1,6 MPa
(1 MPa = 10 bar = 147 PSI)	
Varmtvannstemperatur	maks. 80 °C
Anbefalt temperatur for varmt vann	65 °C
Gjennomstrømningsytelse ved 0,3 MPa:	10 l/min

Armaturer fra Hansgrohe kan brukes sammen med hydraulisk og termisk styrte gjennomstrømningsovner når gjennomstrømningsstrykket er på minst 0,15 MPa.



Enhåndblanderbatterier med varmtvannsbegrensning. For justering se side 23. I forbindelse med en gjennomstrømningsovner er det ikke nødvendig med varmtvannsbegrensning.



Ikke bruk silikon som inneholder eddiksyrer!



Mål (se side 20)



Service deler (se side 22)



Betjening (se side 21)





Rengjøring se vedlagt brosjyre.





Указания за безопасност

-  При монтажа трябва да се носят ръкавици, за да се избегнат наранявания поради притискане или порязване.
-  Големите разлики в налягането между изводите за студената и топлата вода трябва да се изравняват.
-  Само миялни или перални машини, които притежават знак DVGW, могат да бъдат свързани към свързващия клапан без допълнителни приспособления. Ако към свързващия клапан на уреда не бъде свързан консуматор, той трябва да бъде запушен.

Указания за монтаж

- Арматурата трябва да се монтира, промие и провери в съответствие с валидните норми!

Технически данни

Работно налягане:	макс. 1 МПа
Препоръчително работно налягане:	0,1 - 0,5 МПа
Контролно налягане:	1,6 МПа
(1 МПа = 10 bar = 147 PSI)	
Температура на горещата вода:	макс. 80 °C
Препоръчителна температура на горещата вода:	65 °C
Мощност на потока при 0,3 МПа:	10 л/мин

Арматурите на Hansgrohe могат да се използват във връзка с хидравлично и термично управляеми проточни нагреватели, ако хидравличното налягане е минимум 0,15 МПа.



Смесител с една ръкохватка с ограничител за топлата вода, юстирането вижте на стр. 23. Във връзка с проточни нагреватели не е необходима блокировка за топлата вода.



Не използвайте силикон, съдържащ оцетна киселина!



Размери (вижте стр. 20)



Сервизни части (вижте стр. 22)





Обслужване (вижте стр. 21)



Почистване
от приложената брошура.

Udhëzime sigurie

-  Për të evituar lëndimet e pickimeve ose të prerjeve gjatë procesit të montimit duhet që të vishni doreza.
-  Ndryshimet e mëdha të presionit mes lidhjeve të ujit të ftohtë dhe atij të ngrohtë duhen ekuilibruar.
-  Vetëm makinat larëse të enëve ose rrobave që përmbajnë shenjëen e DVGW mund të lidhen me ventilin e lidhjes së pajisjes pa sigurim të posaçëm. Nëse në ventilin e lidhjes së pajisjes nuk lidhet asnjë konsumator, atëherë ky ventil duhet të bllokohet.

Udhëzime për montimin

- Armatura duhet montuar, shpërlarë dhe kontrolluar në bazë të normave të vlefshme!

Të dhëna teknike

Presioni gjatë punës	макс. 1 МПа
Presioni i rekomanduar:	0,1 - 0,5 МПа
Presioni për provë:	1,6 МПа
(1 МПа = 10 bar = 147 PSI)	
Temperatura e ujit të ngrohtë	макс. 80 °C
Temperatura e rekomanduar e ujit të ngrohtë:	65 °C
Kapaciteti i rrjedhjes në 0,3 МПа:	10 л/мин

Armaturat e Hansgrohe mund të përdoren në kombinim me ngrohës elektrik të ujit të drejtuar në mënyrë hidraulike ose termike nëse presioni i rrjedhjes është minimumi 0,15 МПа.



Rubinet me ujë të përzier me kufizim të ujit të ngrohtë, justimi shih faqen 23. Në kombinim me ngrohësit elektrik të ujit nuk ka nevojë për bllokadë të ujit të ngrohtë.



Mos përdorni silikon që në përbërje ka acid acetik.



Përmasat (shih faqen 20)



Pjesë ndërrimi (shih faqen 22)



Përdorimi (shih faqen 21)



Pastrimi
shikoni broshurën bashkëngjitur.



Монтаж
вижте стр. 17

Montimi
shih faqen 17



تنبيهات الأمان



- ⚠ يجب ارتداء قفازات لليد أثناء التركيب لتجنب حدوث أخطار الإنحشار أو الجروح.
- ⚠ يجب أن يكون تيار الماء الساخن والماء البارد متعادلين في الضغط.
- ⚠ يمكن فقط توصيل غسالات الأطباق وغسالات الملابس التي تحمل علامة DVGW بصمام التوصيل بالأجهزة وبدون تأمين إضافي. يجب سد صمام التوصيل بالأجهزة في حالة عدم توصي أية أجهزة.

تعليمات التركيب

- يجب تركيب الوصلة، وغمرها بالماء واختبارها وفقاً للمعايير السارية!

المواصفات الفنية

- ضغط التشغيل: الحد الأقصى 1 ميجاباسكال
- ضغط التشغيل الموصى به: 0,5 - 0,1 ميجاباسكال
- ضغط الاختبار: 1,6 ميجاباسكال
- (1 ميجاباسكال = 10 بار = PSI 147)
- درجة حرارة الماء الساخن: الحد الأقصى 80°C
- درجة الحرارة الموصى بها للماء الساخن: 65°C
- معدل التدفق عند ضغط 0,3 ميجاباسكال: 10 لتر / الدقيقة
- يمكن استخدام خلطات هانزجر وهي مع سخانات تدفق الماء ذات التحكم الهيدروليكي و الحراري، مع ضغط تدفق لا يقل عن 0,15 ميجاباسكال.

لضبط محدد الماء الساخن في الخلطات ذات المقبض الواحد، يرجى الرجوع إلى صفحة 23.
ولا يلزم إجراء أي ضبط عند استخدام سخان مياه ذي تدفق مستمر.



هام! لا تستخدم السليكون الذي يحتوي على أحماض!



أبعاد (راجع صفحة 20)



قطع الغيار (راجع صفحة 22)



التشغيل (راجع صفحة 21)



التنظيف راجع والكتيب المرفق



التركيب

راجع صفحة 17



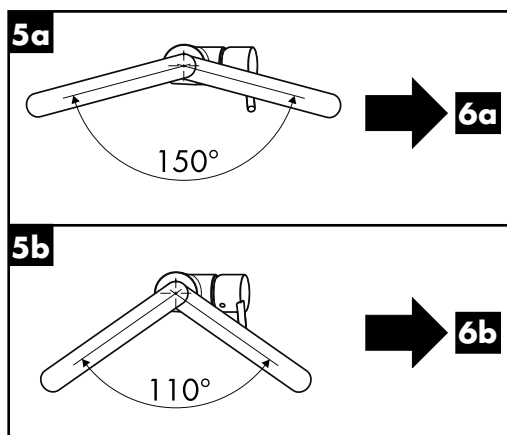
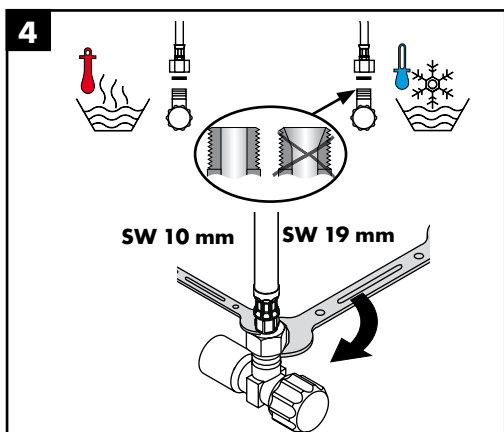
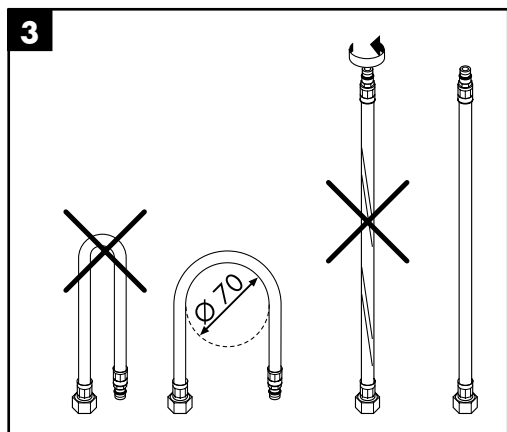
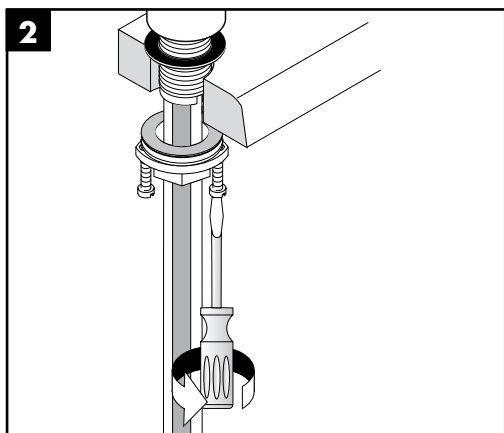
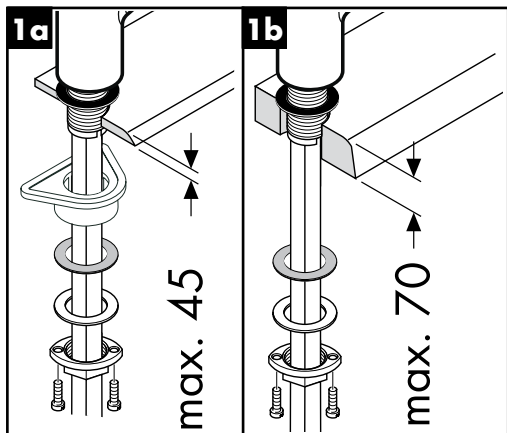



6a

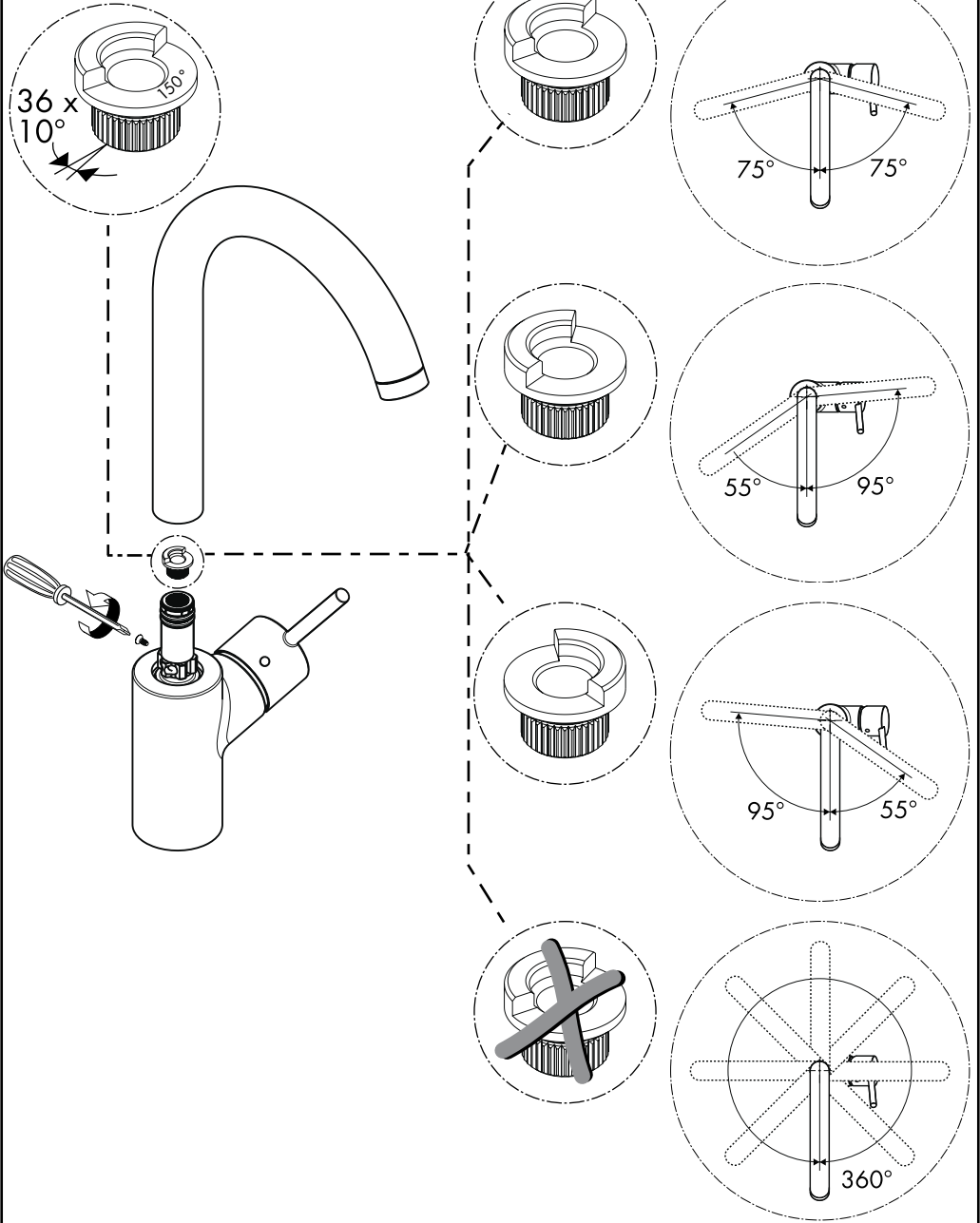



6b

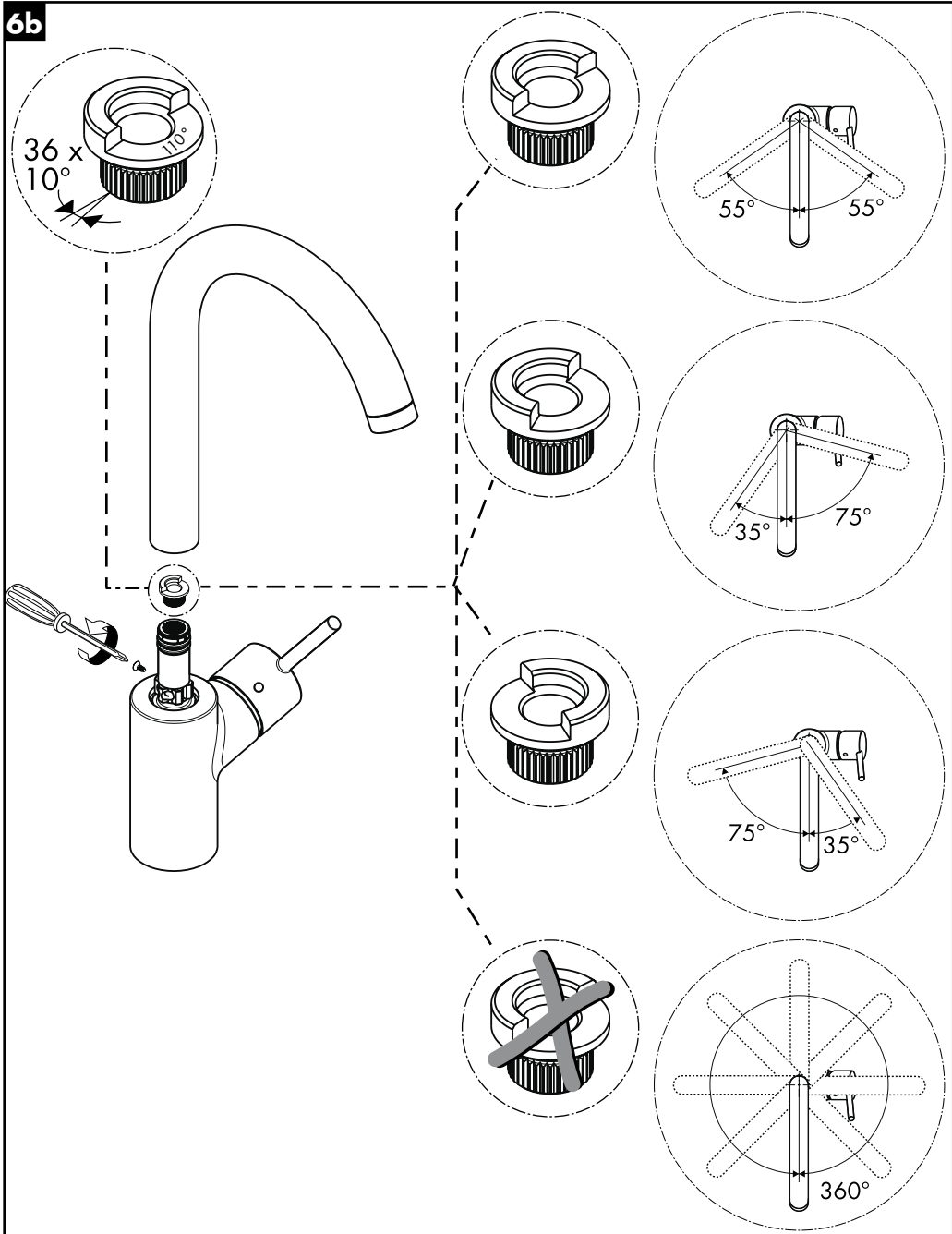



Talis S² Variarc

14870XXX

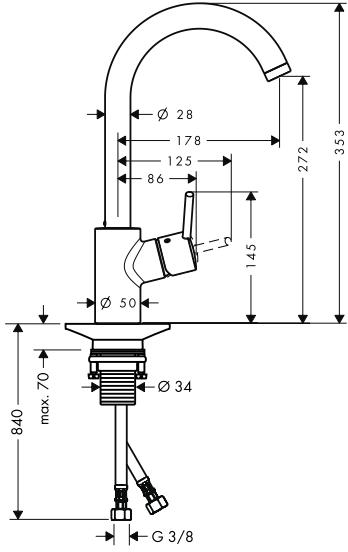

Talis S² Variarc

14875XXX

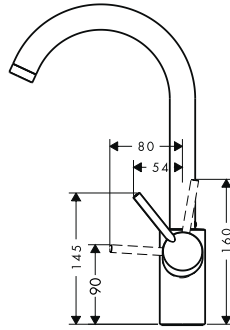
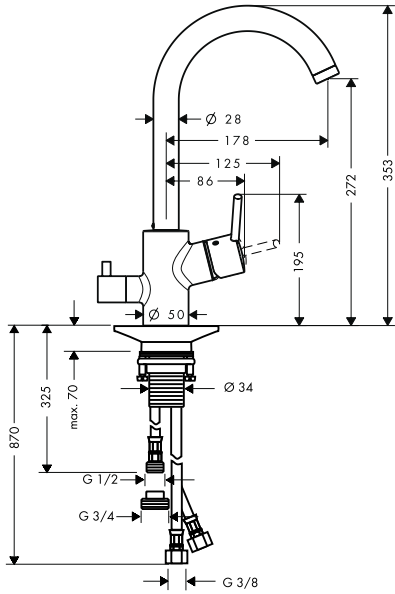

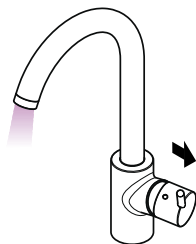

öffnen / ouvert / open / aperto / abierto / open / åbne /
 abrir / otworzyć / otevřít / otvorit / 开 / открыть / nyitás /
 avaaminen / öppna / atidaryti / Отваранье / açmak /
 deschide / ανοικτό / فتح / odpreti / avage / atvērt /
 otvoriti / åpne / отварање / hare

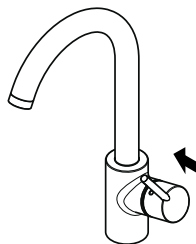

schließen / fermé / close / chiudere / cerrar / sluiten /
 lukke / fechar / zamknąć / zavřít / uzavriev / 关 /
 закрыть / bezárás / sulkeminen / stänga / uždaryti /
 Zatvaranje / kapatmak / închide / κλειστό / إغلاق /
 zapreti / sulgege / aizvērt / zatvori / lukke / затваряње /
 mbylle

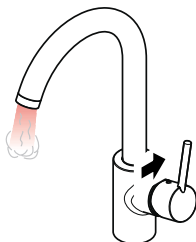

warm / chaud / hot / caldo / caliente / warm / varmt /
 quente / ciepła / teplá / teplá / 热 / горячая / meleg /
 lämmin / varmt / karštas / Vruća voda / sıcak / cald /
 ζεστό / ساخن / toplo / kuum / karsts / topla / varm /
 тепло / i ngrohtë

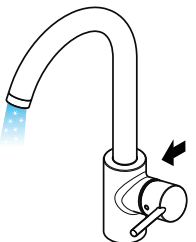

kalt / froid / cold / freddo / frío / koud / koldt / fria /
 zimna / studená / studená / 冷 / холодная / hideg /
 kylmä / kallt / šaltas / Hladno / soğuk / rece / κρύο /
 بارد / mrzlo / külm / auksts / hladno / kaldt / студено /
 i ftohtë

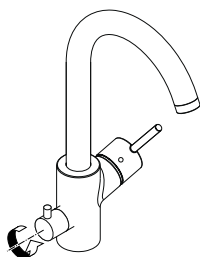

öffnen / ouvert / open / aperto / abierto / open / åbne /
 abrir / otworzyć / otevřít / otvorit / 开 / открыть / nyitás /
 avaaminen / öppna / atidaryti / Отваранье / açmak /
 deschide / ανοικτό / فتح / odpreti / avage / atvērt /
 otvoriti / åpne / отварање / hare

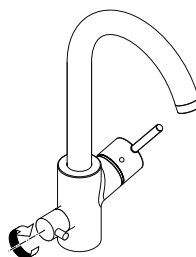

schließen / fermé / close / chiudere / cerrar / sluiten /
 lukke / fechar / zamknąć / zavřít / uzavriev / 关 /
 закрыть / bezárás / sulkeminen / stänga / uždaryti /
 Zatvaranje / kapatmak / închide / κλειστό / إغلاق /
 zapreti / sulgege / aizvērt / zatvori / lukke / затваряње /
 mbylle

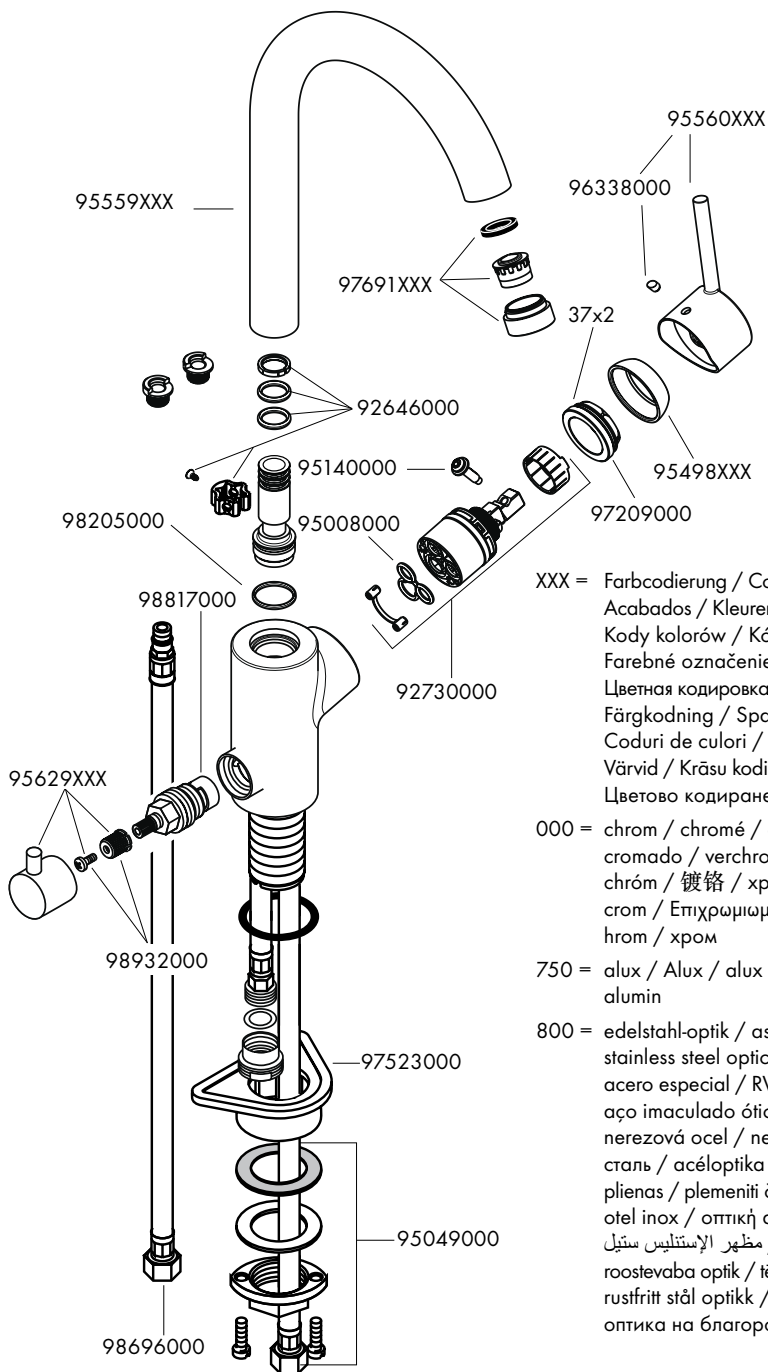

XXX = Farbcodierung / Couleurs / Colors / Trattamento / Acabados / Kleuren / Overflade / Acabamentos / Kody kolorów / Kód povrchové úpravy / Farebné označenie / 顏色代码 / Цветная кодировка / Színkódolás / Värnkoodaus / Färgkodning / Spalvos / Boje / Renkler / Coduri de culori / Χρώματα / ناولال / Barve / Värvid / Krásu kodi / Označe boja / Fargekode / Цветово кодирание / Kodimi me anë të ngjyrave

000 = chrom / chromé / chrome plated / cromato / cromado / verchroomd / Krom / cromado / chróm / 镀铬 / хром / króm / kromi / krom / crom / Επιχρωμιωμένο / حورك / kroom / hroma / hrom / хром

750 = alux / Alux / alux (αλουμινι) / ألأس / алукс / alumin

800 = edelstahl-optik / aspect acier inox / stainless steel optic / acciaio inox acciaio / acero especial / RVS-look / Stainless steel optic / aço imaculado ótica / stal szlachetna / nerezová ocel / nerezova ocel / 不锈钢表面 / сталь / acéloptika / inox-optinen / rostfri-optik / plienas / plemeniti čelik / paslanmaz çelik - optik / otel inox / оптиκή ανοξείδωτου χάλυβα / مظهر الإستانليس ستيل / videz legiranega jekla / roostevaba optik / tērauda / dezen plemeniti čelik / rostfritt stål optikk / оптика на благородна стомана / optikë çeliku

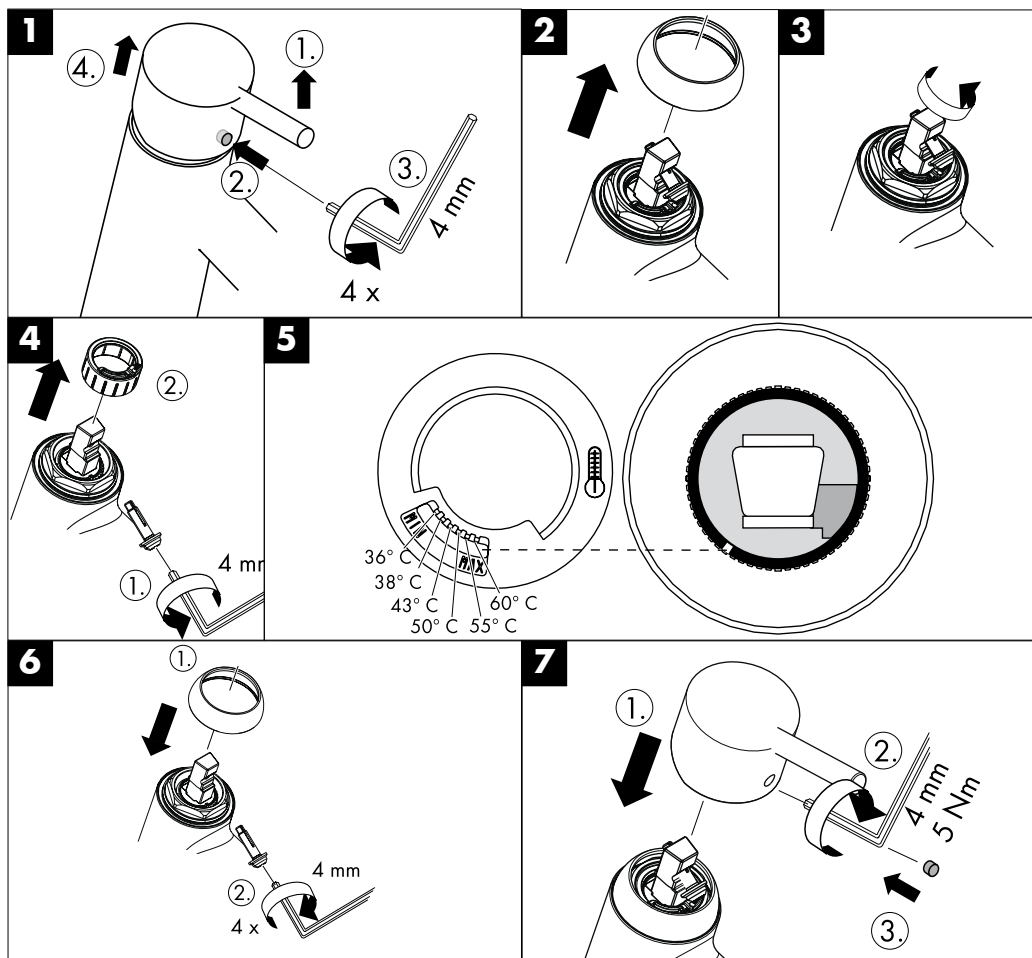

**Prüfzeichen / Classification acoustique et débit / Test certificate / Segno di verifica /
 Marca de verificaci3n / Keurmerk / Godkendelse / Marca de controlo / Znak jakości /
 zkušební značka / Osvedčenie o skúške / 检验标记 / Знак технического контроля / Vizsgajel /
 Koestusmerkki / Testsigill / Bandomo pažyma / Oznaka testiranja / Kontrol isareti /
 Certificat de testare / Σήμα ελέγχου / شهادة اختبار / Preskusni znak / Kontrollsertifikaat /
 Pārbaudes zīme / Ispitni znak / PrøveMERke / Контролен знак / Shenja e kontrollit**

	P-IX	DVGW	SVGW	ACS	WRAS	NF	KIWA
14870XXX	P-IX 9481/IA		X	X	X		X
14875XXX	PA-IX 19374/IA						

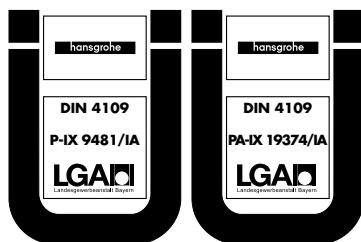

hansgrohe