

<b>DE</b>	Gebrauchsanleitung / Montageanleitung	<b>2</b>
<b>FR</b>	Mode d'emploi / Instructions de montage	<b>4</b>
<b>EN</b>	Instructions for use / assembly instructions	<b>6</b>
<b>IT</b>	Istruzioni per l'uso / Istruzioni per Installazione	<b>8</b>
<b>ES</b>	Modo de empleo / Instrucciones de montaje	<b>10</b>
<b>NL</b>	Gebruiksaanwijzing / Handleiding	<b>12</b>
<b>DK</b>	Brugsanvisning / Monteringsvejledning	<b>14</b>
<b>PT</b>	Instruções para uso / Manual de Instalação	<b>16</b>
<b>PL</b>	Instrukcja obsługi / Instrukcja montażu	<b>18</b>
<b>CS</b>	Návod k použití / Montážní návod	<b>20</b>
<b>SK</b>	Návod na použitie / Montážny návod	<b>22</b>
<b>ZH</b>	用户手册 / 组装说明	<b>24</b>
<b>RU</b>	Руководство пользователя / Инструкция по монтажу	<b>26</b>
<b>HU</b>	Használati útmutató / Szerelési útmutató	<b>28</b>
<b>FI</b>	Käyttöohje / Asennusohje	<b>30</b>
<b>SV</b>	Bruksanvisning / Monteringsanvisning	<b>32</b>
<b>LT</b>	Vartotojo instrukcija / Montavimo instrukcijos	<b>34</b>
<b>HR</b>	Upute za uporabu / Uputstva za instalaciju	<b>36</b>
<b>TR</b>	Kullanım kılavuzu / Montaj kılavuzu	<b>38</b>
<b>RO</b>	Manual de utilizare / Instrucțiuni de montare	<b>40</b>
<b>EL</b>	Οδηγίες χρήσης / Οδηγία συναρμολόγησης	<b>42</b>
<b>SL</b>	Navodilo za uporabo / Navodila za montažo	<b>44</b>
<b>ET</b>	Kasutusjuhend / Paigaldusjuhend	<b>46</b>
<b>LV</b>	Lietošanas pamācība / Montāžas instrukcija	<b>48</b>
<b>SR</b>	Uputstvo za upotrebu / Uputstvo za montažu	<b>50</b>
<b>NO</b>	Bruksanvisning / Montasjeveiledning	<b>52</b>
<b>BG</b>	Инструкция за употреба / Инструкция за употреба	<b>54</b>
<b>SQ</b>	Udhëzuesi i përdorimit / Udhëzime rreth montimit	<b>56</b>
<b>AR</b>	دليل الاستخدام / تعليمات التجميع	<b>59</b>

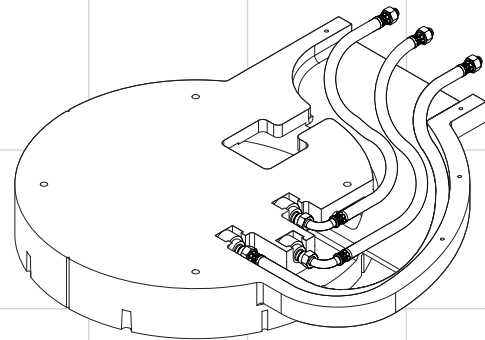

**Rainmaker**  
28412180

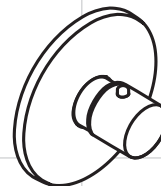
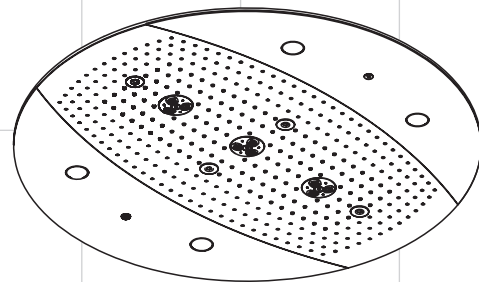

**Rainmaker**  
28403000 / 28404000

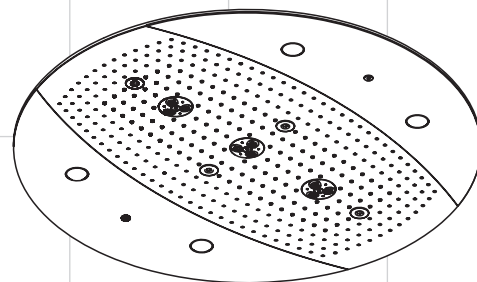

**Rainmaker**  
26115000 / 26117000



## Sicherheitshinweise

- Das Produkt darf nur zu Bade-, Hygiene- und Körperreinigungszwecke eingesetzt werden.
- Kinder, sowie Erwachsene mit körperlichen, geistigen und / oder sensorischen Einschränkungen dürfen nicht unbeaufsichtigt das Produkt benutzen. Personen die unter Alkohol- oder Drogeneinfluss stehen, dürfen das Produkt nicht benutzen.
- Der Kontakt der Brausestrahlen mit empfindlichen Körperstellen (z. B. Augen) muss vermieden werden. Es muss ein ausreichender Abstand zwischen Brause und Körper eingehalten werden.
- Große Druckunterschiede zwischen den Kalt- und Warmwasseranschlüssen müssen ausgeglichen werden.



## Elektroanschluss

- Der Elektroanschluss darf nur vom Elektrofachmann durchgeführt werden!
- Stromversorgung 230V/N/PE/50Hz (Länge: 0,3 m) vorinstallieren.
- Die Absicherung muss über eine Fehlerstrom-Schutzeinrichtung (RCD/ FI) mit einem Bemessungsdifferenzstrom  $\leq 30$  mA erfolgen.



## Montage Grundset (siehe Seite 68)



## Montage Fertigset (siehe Seite 73)

- **Achtung!** Die Armatur muss nach den gültigen Normen montiert, gespült und geprüft werden.
- Bei der Montage des Produktes durch qualifiziertes Fachpersonal ist darauf zu achten, dass die Befestigungsfläche im gesamten Bereich der Befestigung plan ist (keine vorstehenden Fugen oder Fliesenversatz), der Wandaufbau für eine Montage des Produktes geeignet ist und keine Schwachstellen aufweist.
- Die beigelegten Schrauben und Dübel sind nur für Beton geeignet. Bei anderen Wandaufbauten sind die Herstellerangaben des Dübelherstellers zu beachten.
- Die Ablaufleistung muss ausreichend dimensioniert werden.
- Die Brause darf nur nach einem Absperrventil der Sanitärarmatur angeschlossen werden.

## Wartungshinweise

- Rückflussverhinderer müssen gemäß DIN EN 1717 regelmäßig in Übereinstimmung mit nationalen oder regionalen Bestimmungen (DIN 1988 einmal jährlich) auf ihre Funktion geprüft werden.

## Technische Daten

Betriebsdruck vor der Armatur:	max. 1 MPa
Empfohlener Betriebsdruck: (1 MPa = 10 bar = 147 PSI)	0,3 – 0,5 MPa
Heißwassertemperatur:	max. 60 °C
Empfohlene Heißwassertemperatur:	42 °C
Sicherheitsperre:	38 °C
<b>Warnhinweis:</b> Eine Überschreitung dieser Temperatur kann zu Verbrennungen führen!	

Prüfzeichen: SVGW



## Zubehör (siehe Seite 60)



## Maße (siehe Seite 61)



## Montagewerkzeug (siehe Seite 60)



## Montagebeispiele

Installationsbeispiele mit Massangaben und Leitungsdimensionierung sind ab Seite 62 zu finden.

## Bedienung (siehe Seite 76)

## Ersatzteile (siehe Seite 76)



## Service Leuchtmittel austauschen (siehe Seite 77)



## Reinigung (siehe Seite 78)



## Elektroinstallateur

Die Installations- und Prüfungsarbeiten sind von einer zugelassenen Elektrofachkraft, unter Berücksichtigung von VDE 0100 Teil 701 u. IEC 60364-7-701, auszuführen.



Wasseranschluss DN 20  
Warmwasser



Wasser öffnen



Strom an / aus



Wasseranschluss DN 20  
Kaltwasser



Wasser abstellen



Strom an / aus



Unterputz-Ventil



Montageabfolge



Potentialausgleich



Quattro Vierwegeumstellung



Silikon (essigsäurefrei!)



Nullleiter

**Quattro**



Trio Universal Absperr- und Umstell-  
ventil



Leerrohr für Stromversorgung



Leiter

**Trio**



Ab • ist die Funktion gewährleistet.



Fett



FI-Schutzschalter



Die Ablaufleistung muss mehr als  
50 l/min betragen.



Warnung vor heißer Oberfläche!



Anschlussdose

> 50 l/min



Ablauf



Schutzhandschuhe tragen



Lichtschalter

**Raindrain**

**X**

Mitte Duschwanne



Augenschutz tragen



Trafo



Naturschwamm



Steckverbindungen



**Entkalker** (zitronensäurebasis)

Augen- und Hautkontakt vermeiden.  
Falls das Produkt in die Augen ge-  
langt, diese gründlich mit Wasser aus-  
spülen.



Verteilerbox



Leuchtmittel

**QUICK CLEAN** Mit QuickClean, der manuellen Reini-  
gungsfunktion können die Strahlformer  
durch einfaches rubbeln vom Kalk be-  
freit werden.



### Consignes de sécurité

- Le système de douche ne doit servir qu'à se laver et à assurer l'hygiène corporelle.
- Il est interdit aux enfants ainsi qu'aux adultes ayant des insuffisances physiques, psychiques et/ou motoriques d'utiliser la douche sans surveillance. De même, il est interdit à des personnes sous influence d'alcool ou de drogues d'utiliser la douche.
- Éviter le contact du jet de la douchette avec les parties sensibles du corps (telles par ex. que les yeux). Veiller à respecter un écart suffisant entre la douchette et le corps
- Il est conseillé d'équilibrer les pressions de l'eau chaude et froide.



### Raccord électrique

- Seul un spécialiste est autorisé à réaliser le câblage!
- Préinstaller l'alimentation électrique 230V/N/PE/50Hz (longueur : 0,3 m)
- La protection par fusibles doit se faire avec un dispositif de protection par courant de défaut (RCD/ FI) avec un courant différentiel résiduel de maximum 30 mA.



### Montage Kit de base (voir page 68)



### Montage Set de finition (voir page 73)

- **Attention!** La robinetterie doit être installée, rincée et contrôlée conformément aux normes valables.
- Lors du montage du produit par un ouvrier qualifié, il faut faire attention à ce que la surface de fixation soit plane sur toute son étendue (aucun dépassement de joint ni de carrelage), que la construction de la paroi soit adaptée à l'installation du produit et surtout ne présente aucun point faible.
- Les vis et les chevilles fournies sont uniquement appropriées au béton. Pour les autres constructions, il faudra tenir compte des préconisations du fabricant de cheville.
- Le débit du vidage doit être suffisamment dimensionné.
- La douchette ne doit être raccordée à la robinetterie sanitaire qu'en aval d'une vanne d'arrêt.

### Recommandations pour la maintenance

- Les clapets anti-retour doivent être examinés régulièrement conformément à la norme EN 1717 ou conformément aux dispositions nationales ou régionales quant à leur fonction (au moins une fois par an).

### Informations techniques

Pression de service devant la robinetterie:	max. 1 MPa
Pression de service conseillée:	0,3 - 0,5 MPa
(1 MPa = 10 bar = 147 PSI)	
Température d'eau chaude:	max. 60 °C
Température recommandée:	42 °C
Blocage de sécurité:	38 °C

**Avertissement:** tout dépassement de cette température peut entraîner des brûlures

Classification acoustique et débit: SVGW / ACS



### Accessoires (voir page 60)



### Dimensions (voir page 61)



### Outil de montage (voir page 60)



### Exemples de montage

Des exemples d'installation avec indication de cotes et dimensions des conduites sont fournis à partir de la page 62.

### Instructions de service (voir page 76)

### Pièces de rechange (voir page 76)



### Service Remplacer l'élément lumineux (voir page 77)



### Nettoyage (voir page 78)



### Électricien installateur

Les travaux d'installation et de contrôle doivent être effectués par un électricien agréé en conformité avec les dispositions des normes VDE 0100 partie 701 et CEI 60364-7-701.



Raccord d'eau DN 20  
Eau chaude



Ouvrir l'eau.



Courant marche / arrêt



Raccord d'eau DN 20  
Eau froide



Couper l'arrivée d'eau



Courant marche / arrêt



Robinet d'arrêt encastré



Ordre du montage



Compensation de potentiel



Quattro inverseur quatre voies



Silicone (sans acide acétique!)



Neutre

**Quattro**



Trio Robinet d'arrêt avec inverseur



Gaine pour alimentation en courant électrique



Conducteur

**Trio**



A partir de • le fonctionnement est garanti.



Graisse



Disjoncteur FI



Le débit de vidage doit être supérieur à 50 l/min.



Attention à la température élevée à la surface !



boîtier de raccordement



Vidage



Protection obligatoire des mains



Interrupteur d'éclairage

**Raindrain**



Centre cuvette de douche



Protection obligatoire de la vue



transfo



éponge naturelle



Connecteur



**Détartrant** (À base d'acide citrique)

Éviter tout contact avec les yeux et la peau. Si le produit saute aux yeux, rincer ces derniers à l'eau abondante



Distributeur



Moyen d'éclairage

**QUICK CLEAN** La pomme de douche est équipée de QuickClean, le système anticalcaire manuel. Les dépôts de calcaire s'enlèvent en frottant avec un doigt ou avec une éponge sur les ouvertures de jets élastiques.



### Safety Notes

- The shower system may only be used for bathing, hygienic and body cleansing purposes.
- Children as well as adults with physical, mental and/or sensoric impairments must not use this shower system without proper supervision. Persons under the influence of alcohol or drugs are prohibited from using this shower system.
- Do not allow the streams of the shower touch sensitive body parts (such as your eyes). An adequate distance must be kept between the shower and you.
- The hot and cold supplies must be of equal pressures.



### Electrical connection

- The electrical connection may only be carried out by an electrician!
- Preinstall electrical power 230 V/N/PE/50 Hz (length: 0.3 m)
- The system must be protected via a leakage current protective device (RCD/ FI) with a measurement difference current of  $\leq 30$  mA.



### Assembly basic kit (see page 68)



### Assembly Finish set (see page 73)

- **Important!** The fitting must be installed, flushed and tested after the valid norms.
- Where the contractor mounts the product, he should ensure that the entire area of the wall to which the mounting plate is to be fitted, is flat (no projecting joints or tiles sticking out), that the structure of the wall is suitable for the installation of the product and has no weak points.
- The enclosed screws and dowels are only suitable for concrete. For another wall constructions the manufacturer's indications of the dowel manufacturer have to be taken into account.
- The performance of the waste must be of sufficient size.
- The shower may only be connected following (downstream from) a shut-off valve of the sanitary fitting.

### Maintenance Instructions

- The non return valves must be checked regularly according to DIN EN 1717 in accordance with national or regional regulations (at least once a year).

### Technical Data

Operating pressure in front of the shower fitting: max. 1 MPa  
Recommended operating pressure: 0,3 - 0,5 MPa  
(1 MPa = 10 bar = 147 PSI)  
Hot water temperature: max. 60 °C  
Recommended hot water temp.: 42 °C  
safety lock: 38 °C

**Warning:** Exceeding this temperature can cause burns!



### Fittings (see page 60)



### Dimensions (see page 61)



### Installation tool (see page 60)



### Installation example

Installation examples with measurements and pipe dimensions can be found starting on page 62.

### Operation (see page 76)

### Spare parts (see page 76)



### Service Replace illuminant (see page 77)



### Cleaning (see page 78)



### Electrician

The installation and testing work must be performed by a skilled electrician in observance of VDE 0100 part 701 and IEC 60364-7-701.

# English



Water connection DN 20  
Warm water



Water connection DN 20  
Cold water



Robinet d'arrêt encastré



Quattro 4-Way Diverter Valve

**Quattro**



Trio 2-Way Diverter Valve with integrated Shut-off valve

**Trio**



From • the function is guaranteed.



The waste drain performance must be more than 50 l/min.

> 50 l/min



Waste

**Raindrain**



Center shower tub



Turn on water



turn off water



Installation sequence



Silicone (free from acetic acid!)



Wiring conduit for power supply cable



Grease



Hot surface!



Safety gloves must be worn



Eye protection must be worn



natural sponge



**Decalcifier** (Citric acid base)

Avoid contact with eyes and skin. If this product contacts your eyes, rinse thoroughly with water.



Electricity on / off



Electricity on / off



Potential equalisation



neutral conductor



conductor



FI protective switch



junction box



light switch



transformer



connectors



distributor box



illuminant

**QUICK CLEAN** The QuickClean cleaning function only needs a small manual rub over to remove the lime scale from the spray channels.

Assembly see page 68



### Indicazioni sulla sicurezza

- Il sistema doccia deve essere utilizzato esclusivamente per l'igiene del corpo.
- I bambini e gli adulti affetti da menomazioni fisiche, psichiche e/o sensoriali devono utilizzare il sistema doccia solo sotto sorveglianza. Il prodotto non deve essere utilizzato da persone sotto l'effetto di droghe o alcolici.
- Bisogna evitare il contatto fra il getto della doccia e parti del corpo delicate (ad es. gli occhi). Fra il soffione ed il corpo va mantenuta una distanza sufficiente.
- Attenzione! Compensare le differenze di pressione tra i collegamenti dell'acqua fredda e dell'acqua calda.



### Allacciamento elettrico

- Il cablaggio deve essere eseguito esclusivamente da un installatore specializzato!
- Preinstallare l'alimentazione elettrica di 230V/N/PE/50Hz (lunghezza: 0,3 m).
- Per protezione bisogna installare un circuito di sicurezza per correnti di guasto (RCD/ FI) con una corrente differenziale nominale di  $\leq 30$  mA.



### Montaggio corpo base (vedi pagg. 68)



### Montaggio Set esterno (vedi pagg. 73)

- **Attenzione!** La rubinetteria deve essere installata, pulita e testata secondo le istruzioni riportate!
- Quando il personale tecnico specializzato esegue il montaggio del prodotto è necessario assicurarsi che la superficie di fissaggio sia piana in tutta l'area di fissaggio (senza giunti sporgenti o spostamento delle piastrelle), che la struttura della parete sia adatta per il montaggio del prodotto e soprattutto che non ci siano dei punti deboli.
- Le viti e i tasselli in dotazione sono adatti solo per calcestruzzo. In caso di altre strutture della parete vanno osservare le indicazioni del produttore dei tasselli.
- Lo scarico deve essere sufficientemente dimensionato.
- La doccia deve essere collegata solo a valle di una valvola d'arresto dell'armatura sanitaria.

### Istruzioni di manutenzione

- La valvola di non ritorno deve essere controllata regolarmente come da DIN EN 1717, secondo le normative nazionali e regionali (almeno una volta all'anno).

### Dati tecnici

Pressione di servizio prima della rubinetteria: max. 1 MPa  
 Pressione d'uso consigliata: 0,3 - 0,5 MPa  
 (1 MPa = 10 bar = 147 PSI)  
 Temperatura dell'acqua calda: max. 60 °C  
 Temp. dell'acqua calda consigliata: 42 °C  
 Blocco di sicurezza: 38 °C

**Avvertenza:** il superamento di questa temperatura può causare delle ustioni!

Segno di verifica

SVGW



### Accessori (vedi pagg. 60)



### Ingombri (vedi pagg. 61)



### Attrezzo di montaggio (vedi pagg. 60)



### Esempio di installazione

Esempi per l'installazione con indicazioni delle misure e per le dimensioni delle tubature sono riportati a partire dalla pagina 62.

### Procedura (vedi pagg. 76)

### Ricambi (vedi pagg. 76)



### Servizio Sostituzione lampada (vedi pagg. 77)



### Pulitura (vedi pagg. 78)



### Installatore elettricista

I lavori di installazione e di controllo vanno eseguiti da un elettricista specializzato autorizzato, in considerazione della normativa VDE 0100 Parte 701 e IEC 60364-7-701.

Montaggio vedi pagg. 68





Allacciamento acqua DN 20  
Acqua calda



Aprire l' acqua



Corrente ON / OFF



Allacciamento acqua DN 20  
Acqua fredda



Chiudere l' acqua



Corrente ON / OFF



Rubinetto di arresto



Sequenza di montaggio



Compensazione di potenziale



Quattro Valvola a quattro vie



Silicone (esente da acido acetico!)



conduttore neutro

**Quattro**



Trio arresto/deviatore



Tubo vuoto per l'alimentazione elettrica



conduttore

**Trio**



Dal • si garantisce la funzionalità.



Grasso



interruttore di sicurezza per correnti di guasto



La portata di scarico deve essere superiore a 50 l/min.

> 50 l/min



Attenzione, superficie molto calda!



scatola di raccordo

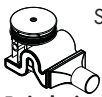

Scarico

**Raindrain**



Indossare guanti di protezione



interruttore luce

**X**

Centro piatto doccia



Indossare la protezione per gli occhi



trasformatore



Spugna naturale



collegamenti a spina



**Decalcificatore** (a base di acido citrico)

Evitare il contatto con gli occhi e la pelle. Nel caso il prodotto penetra negli occhi, sciacquarlo accuratamente con acqua.



cassetta distribuzione



Lampada

**QUICK CLEAN** Con QuickClean, la funzione anticalcare manuale, i diffusori del getto possono essere liberati da calcare con un semplice strofinamento.



### Indicaciones de seguridad

- El sistema de ducha solo debe ser utilizado para fines de baño, higiene y limpieza corporal.
- Niños, así como adultos con limitaciones corporales, mentales y/o sensoriales no deben utilizar el sistema de duchas sin vigilancia. Personas que se encuentran bajo el efecto de alcohol o drogas, no deben utilizar el sistema de duchas.
- Debe evitarse el contacto del chorro del pulverizador con partes sensibles del cuerpo (por ej. ojos). Debe mantenerse una distancia suficiente entre pulverizador y cuerpo.
- Grandes diferencias de presión entre los empalmes de agua fría y agua caliente deben equilibrarse.



### Conexión eléctrica

- ¡Sólo un especialista está autorizado para llevar a cabo los trabajos de cableado!
- Instalar previamente el suministro eléctrico 230V/N/PE/50Hz (longitud: 0,3 m).
- La conexión debe establecerse a través de un dispositivo de protección de corriente residual (RCD/ FI) con un interruptor diferencial de corriente  $\leq 30$  mA.



### Montaje Kit base (ver página 68)



### Montaje Embellecedor exterior (ver página 73)

- **¡ATENCIÓN!** El grifo tiene que ser instalado, probado y testado, según las normas en vigor.
- En el momento del montaje del producto por parte de personal especializado y cualificado se deberá prestar una atención especial a que la superficie de fijación en toda el área de la fijación sea plana (sin juntas que sobresalen ni azulejos desplazados), que la estructura de la pared sea adecuada para un montaje del producto y que, ante todo, no presente puntos débiles.
- Los tornillos y tacos adjuntos son sólo apropiados para hormigón. En el caso de otras estructuras murales se deberán considerar las indicaciones del fabricante de tacos.
- La tubería de desagüe ha de tener una dimensión suficiente.
- La roseta de ducha debe conectarse siempre detrás de una válvula de bloqueo de la valvulería sanitaria.

### Instrucciones de mantenimiento

- Las válvulas anti-retorno tienen que ser controladas regularmente según la norma DIN EN 1717, en acuerdo con las regulaciones nacionales o regionales (una vez al año, por lo menos).

### Datos técnicos

Presión de servicio delante de la grifería:	max. 1 MPa
Presión recomendada en servicio:	0,3 - 0,5 MPa
(1 MPa = 10 bar = 147 PSI)	
Temperatura del agua caliente:	max. 60 °C
Temp. recomendada del agua caliente:	42 °C
Bloqueo de seguridad:	38 °C

**Aviso de peligro:** si se supera esta temperatura pueden provocarse quemaduras.



### Accesorios (ver página 60)



### Dimensiones (ver página 61)



### Herramienta de montaje (ver página 60)



### Ejemplos de montaje

A partir de la página 62 puede consultar ejemplos de instalación y dimensionamiento de la conducción.

### Manejo (ver página 76)

### Piezas de recambio (ver página 76)



### Reparación Cambio de luminarias (ver página 77)



### Limpiar (ver página 78)



### Instalador eléctrico

Las tareas de instalación y prueba únicamente pueden ser realizadas por personal electricista cualificado, respetando las regulaciones de las normas VDE 0100, parte 701, e IEC 60364-7-701.



Conexión de agua DN 20  
Agua caliente



Abrir el agua



Corriente on / off



Conexión de agua DN 20  
Agua fría



Cerrar el agua



Corriente on / off



Llave de paso



Secuencia de montaje



Protección equipotencial



Quattro válvula de 4 vías



Silicona (¡libre de ácido acético!)



Conductor neutro

**Quattro**



Trio llave de paso y distribuidor



Tubo vacío para alimentación eléctrica



Conductor

**Trio**



Mínimo • para el correcto funcionamiento.



Grasa



Conmutador de protección FI



El caudal de desagüe debe ser como mínimo de 50 l/min

> 50 l/min



¡Atención, superficie muy caliente!



Caja de conexión

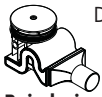

Desagüe



Protección obligatoria de la vista



Interruptor de luz

**Raindrain**

**X**

Centro la plato de ducha



Protección obligatoria de las manos



Transformador



Esponja natural



Uniones insertables



**Descalcificador** (a base de ácido cítrico)

Evitar el contacto con ojos y piel. En caso de que el producto entre en contacto con los ojos, debe lavarlos muy bien con agua.



Caja de distribución



Luces

**QUICK CLEAN** QuickClean, la función de limpieza manual, permite quitar la cal simplemente frotando los ejectores.



## Veiligheidsinstructies

- Het douchesysteem mag alleen voor het wassen, hygiënische doeleinden en voor de lichaamreiniging worden gebruikt.
- Kinderen en volwassenen met lichamelijke, geestelijke en/of sensorische beperkingen mogen het douchesysteem niet zonder toezicht gebruiken. Personen onder invloed van alcohol of drugs mogen het douchesysteem niet gebruiken.
- Het contact van de douchestraal met gevoelige lichaamsdelen (bijv. ogen) moet worden voorkomen. Er moet voldoende afstand tussen douche en lichaam aangehouden worden.
- Grote drukverschillen tussen de kouden warm wateraansluitingen dienen vermeden te worden.



## Elektrische aansluiting

- De elektrische aansluiting mag alleen door een vakman worden uitgevoerd!
- Stroomvoorziening 230V/N/PE/50Hz (lengte: 0,3 m) vooraf installeren.
- Deze moet middels een 2-polige FI-schakelaar met 30mA afgezekerd worden.



## Montage Basisset (zie blz. 68)



## Montage Kleurset (zie blz. 73)

- **Attentie!** Leidingen doorspoelen volgens Norm. De mengkraan vervolgens monteren en controleren.
- Bij de montage van het produkt door een vakkundige installateur moet men erop letten dat het bevestigingsoppervlak op één oppervlak zit (dus geen opliggende voegen of verspringende tegels), de wand geschikt is voor montage van produkten en zeker geen zwakke plekken bevat.
- De bijgevoegde schroeven en duvels zijn alleen geschikt voor beton. Bei andere wandsoorten dient u te letten op de voorschriften van de fabrikant van de schroeven en duvels.
- De afvoercapaciteit moet voldoende gedimensioneerd worden.
- De douche alleen installeren na een afsluitbare kraan.

## Onderhoudsinstructies

- Keerkleppen moeten volgens DIN EN 1717 regelmatig en volgens plaatselijk geldende eisen op het functioneren gecontroleerd worden. (Tenminste een keer per jaar).

## Technische gegevens

Stroomdruk voor de kraan:	max. 1 MPa
Aanbevolen werkdruk:	0,3 - 0,5 MPa
(1 MPa = 10 bar = 147 PSI)	
Temperatuur warm water:	max. 60 °C
Aanbevolen warm water temp.:	42 °C
Veiligheidsmechanisme:	38 °C

**Waarschuwing:** Een overschrijding van die temperatuur kan brandwonden veroorzaken!



## Toebehoren (zie blz. 60)



## Maten (zie blz. 61)



## Montagegereedschap (zie blz. 60)



## Montagevoorbeelden

Installatievoorbeelden met massagegevens en capaciteitsdimensionering staan op pagina 62.

## Bediening (zie blz. 76)

## Reserveonderdelen (zie blz. 76)



## Service Verlichting vervangen (zie blz. 77)



## Reinigen (zie blz. 78)



## Electro-installateur

De installatie- en controlewerkzaamheden moeten uitgevoerd worden door een geautoriseerde electricien die rekening houdt met de normen VDE 0100 Deel 701 en IEC 60364-7-701.

## Nederlands



Wateraansluiting DN 20  
Warm water



Wateraansluiting DN 20  
Koud water



Inbouwstopkraan



Quattro 4-weg omstelkraan

**Quattro**



Trio stop- en omstelkraan

**Trio**



Vanaf • is het functioneren gegarandeerd.



De afvoercapaciteit moet meer dan 50 l/min bedragen.

> 50 l/min

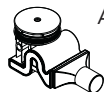

Afvoer

**Raindrain**

**X**

Midden Douchebak



Hoofdkraan openen



Water afsluiten



Montagevolgorde



Silicone (azijnzuurvrij!)



Loze leiding voor stroom toevoer



Vet



Let op: heet!



Veiligheidshandschoenen verplicht



Oogbescherming verplicht



Natuurzwam



**Ontkalker** (citroenzuurbasis)

Contact met huid en ogen vermijden. Indien het product in de ogen terecht komt, moet het grondig met water uitgespoeld worden.



Stroom aan / uit



Stroom aan / uit



Potentiaalvereffening

**N**

Nulgeleider

**L**

Geleider



FI-veiligheidsschakelaar



aansluiting



Lichtschakelaar



trafo



Steekverbinding



Verdeelbox



Verlichtingsmiddel

**QUICK CLEAN** Met QuickClean, de handmatige reinigingsfunctie, kunnen de straalopeningen door het met de hand wegwrijven van kalk, gereinigd worden.

**Montage zie blz. 68**



### Sikkerhedsanvisninger

- Brusersystemet må kun bruges til bade-, hygiejne og rengøringsformål.
- Børn som også voksne med fysiske, mentale og / eller sensoriske begrænsninger må ikke bruge brusersystemet uden opsyn. Personer som er under indflydelse af alkohol eller narkotika må ikke bruge brusersystemet.
- Bruserstrålens kontakt med sensitive områder (f.eks. øjne) skal undgås. Der skal være en tilstrækkelig afstand mellem bruseren og kroppen.
- Større trykforskelle mellem koldt og varmt vand bør udjævnes.



### El-tilslutning

- Ledningsarbejde må kun foretages af en fagmand!
- Strømforsyning 230V/N/PE/50Hz (længde: 0,3 m) allerede installeret.
- Sikringen skal køre over en fejlstrømssikring (HFI) med en fejlstrømsdifference  $\leq 30$  mA.



### Montering Basis-sæt (se s. 68)



### Montering Kappesæt (se s. 73)

- **Advarsel!** Ifølge gældende regler, skal armaturet monteres, skylles igennem og afprøves.
- Ved montering er det vigtigt at sikre sig, at hele befæstigelsesfladen er plan (ingen ujævne fuger eller fliser), samt at væggen er egnet til montering af produktet og specielt, at væggen ikke har nogen svage punkter.
- De medfølgende skruer og dübler er kun egnet til beton. Ved anden vægopbygning bør producenten af dübler kontaktes for nærmere information.
- Afløbet skal være i en tilstrækkelig størrelse.
- Bruseren må kun tilsluttes til armaturen efter en afspærringsventil.

### Vedligeholdelsesanvisninger

- Ifølge DIN EN 1717 skal gennemstrømningsbegrænsere i overensstemmelse med nationale regler afprøves regelmæssigt (mindst en gang om året).

### Tekniske data

Betjeningstryk før armaturet:	max. 1 MPa
Anbefalet driftstryk:	0,3 - 0,5 MPa
(1 MPa = 10 bar = 147 PSI)	
Varmtvandstemperatur:	max. 60 °C
Anbefalet varmtvandstemperatur:	42 °C
Sikkerhedsspærre:	38 °C

**Advarsel:** Hvis temperaturen overskrides kan det føre til forbrændinger!



### Tilbehør (se s. 60)



### Målene (se s. 61)



### Montagegreedschap (se s. 60)



### Monteringseksempler

Installationseksempler med mål og ledningsdimensioner kan efterlæses fra side 62.

### Brugsanvisning (se s. 76)

### Reserve dele (se s. 76)



### Service Udskifte lyskilden (se s. 77)



### Rengøring (se s. 78)



### El-installatør

Installeringen og afprøvningen skal gennemføres af en godkendt el-installatør iht. VDE 0100 part 701 og IEC 60364-7-701.



Vandtilslutning DN 20  
Varmt vand



Tænd for vandet



Strøm til / fra



Vandtilslutning DN 20  
Kold vand



Luk for vandet



Strøm til / fra



Afspæringsventil



Monteringsrækkefølge



Potentialudligning



Quattro 4-vejs ventil



Silikone (eddikesyre-fri)



Nulleleder

**Quattro**



Trio afspæringsventil og omskifter



Tomrør til strømforsyning



Leder

**Trio**



Fra • er funktionen anvendelig.



Fedt



FI-beskyttelseskontakt



Afløbskapaciteten skal være mere end  
50 l/min.

> 50 l/min



Varm overflade!



Tilslutningsdåse

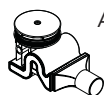

Afløb



Veiligheidshandschoenen verplicht



Lyskontakt

**Raindrain**

**X**

Midt brusekar



Øjenværn påbudt



Transformer



Natursvamp



Stikforbindelser



**Afkalkningsmiddel** (citron-  
syrebasis)

Undgå kontakt med øjne og huden.  
Skyl grundigt med vand, hvis produktet  
kommer i øjnene.



Fordelingskasse



Lyskilde

**QUICK CLEAN** Med QuickClean, den manuelle rengøringsfunktion kan strålekanalerne let renses for kalk - der skal blot gnubbes!



## Avisos de segurança

- O sistema de duche só pode ser utilizado para fins de higiene pessoal.
- Crianças e adultos com deficiências motoras, mentais e/ou sensoriais não podem utilizar o sistema de duche sem monitorização. Pessoas que estejam sob a influência de álcool ou drogas não podem utilizar o sistema de duche.
- Deve-se evitar o contacto dos jactos de água com partes do corpo sensíveis (p. ex. olhos). É necessário manter uma distância suficiente entre o chuveiro e o corpo.
- Grandes diferenças entre as pressões das águas quente e fria devem ser compensadas.



## Ligação eléctrica

- A instalação eléctrica deve ser efectuada apenas por um electricista qualificado!
- Pré-instalar a alimentação eléctrica 230V/N/PE/50Hz (comprimento: 0,3 m).
- A ligação deve estar protegida por um diferencial magneto-térmico bipolar (RRCB) com uma corrente residual  $\leq 30$  mA.



## Montagem Corpo base (ver página 68)



## Montagem Conjunto completo (ver página 73)

- **Atenção!** A misturadora deve ser instalada, purgada e testada de acordo com as normas em vigor.
- Durante a montagem do produto por técnicos qualificados, deve ter-se em atenção que a superfície de fixação seja plana em toda a área da fixação (sem juntas sobrepostas/salientes ou ladrilhos deslocados), que o dispositivo de montagem na parede seja adequado para uma montagem na parede e que este não apresente nenhuns pontos fracos.
- Os parafusos e buchas incluídos no volume de fornecimento são apenas adequados para betão. Para outros métodos de montagem na parede devem ser respeitadas as indicações do fabricante das buchas.
- A capacidade de escoamento deve ser devidamente dimensionada.
- O chuveiro só pode ser instalado a seguir a uma válvula de retenção da valvularia de sanitários.

## Avisos de manutenção

- As válvulas anti-retorno devem ser verificadas regularmente de acordo com a DIN EN 1717 segundo os regulamentos nacionais ou regionais (pelo menos uma vez por ano).

## Dados Técnicos

Pressão de funcionamento anterior à misturadora: max. 1 MPa  
Pressão de func. recomendada: 0,3 – 0,5 MPa  
(1 MPa = 10 bar = 147 PSI)  
Temperatura da água quente: max. 60 °C  
Temp. água quente recomendada: 42 °C  
Bloqueio de segurança: 38 °C

**Aviso de advertência:** Exceder esta temperatura pode causar queimaduras!



## Acessórios (ver página 60)



## Medidas (ver página 61)



## Ferramenta de montagem (ver página 60)



## Exemplos de montagem

Exemplos de instalação com indicações dimensionais e dimensionamento das tubagens, podem ser encontrados a partir da página 62.

## Funcionamento (ver página 76)

## Peças sobressalentes (ver página 76)



## Manutenção Substituir lâmpada

(ver página 77)



## Limpeza (ver página 78)



## Electricista de construção civil

Os trabalhos de instalação e de controlo devem ser efectuados por um técnico electricista devidamente autorizado e especializado, tendo em consideração as normas VDE 0100 Parte 701 e IEC 60364-7-701.





Ligação da água DN 20  
Água quente



Abrir a água



Electricidade ligada/desligada



Ligação da água DN 20  
Água fria



Cortar a água



Electricidade ligada/desligada



Torneira de passagem



Sequência de montagem



Ligação equipotencial



Quatro válvula de diversão de 4 vias



Silicone (sem ácido acético)



Condutor neutro

**Quatro**



Trio universal inversor/válvula de corte



Tubo VD para alimentação eléctrica



Condutor

**Trio**



• A partir deste ponto inicia-se o funcionamento correcto.



Massa lubrificante



Interruptor FI



Capacidade de escoamento tem que ser superior a 50 l/min.

> 50 l/min



Superfície quente!



Caixa de derivação

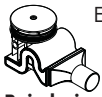

Escoamento

**Raindrain**



Protecção obrigatória das mãos



Interruptor de luz

**X**

Meio da base de duche



Protecção obrigatória dos olhos



Transformador



Esponja natural



Tomadas de ligação



**Descalcificador** (À base de ácido cítrico)

Evitar contacto com os olhos e pele. Se o produto entrar em contacto com os olhos deve lavar abundantemente com água.



Caixa de distribuição



Lâmpada

**QUICK CLEAN** O sistema de limpeza QuickClean requer apenas uma ligeira passagem com a mão para remover os depósitos de calcário do emulsor.

**Wskazówki bezpieczeństwa**

- Prysznic może być używany tylko do kąpieli, higieny i czyszczenia ciała.
- Zarówno dzieci, jak i dorośli z fizycznymi, psychicznymi i/lub sensorycznymi ograniczeniami nie mogą korzystać z prysznica bez opieki. Osoby znajdujące się pod wpływem alkoholu lub narkotyków nie mogą korzystać z prysznica.
- Należy unikać kontaktu strumienia wypływającego z głowicy z wrażliwymi częściami ciała (np. oczami). Należy zachowywać odpowiednią odległość pomiędzy głowicą a ciałem.
- Znaczne różnice ciśnień na dopływach ciepłej i zimnej wody muszą zostać wyrównane.

**Przyłącze elektryczne**

- Podłączenie elementów elektrycznych może być przeprowadzone jedynie przez fachowca elektryka!
- Zasilanie prądem 230V/N/PE/50Hz (długość: 0,3 m) zainstalować wstępnie.
- Zabezpieczenie instalacji musi mieć miejsce przy użyciu zabezpieczenia różnicowego (RCD/ FI) z różnicą pomiarów wynoszącą  $\leq 30$  mA.

**Montaż Zestaw podstawowy** (patrz strona 68)**Montaż Elementy zewnętrzne** (patrz strona 73)

- **Uwaga!** Armatura musi być zamontowana, przepłukana i wypróbowana według obowiązujących norm.
- Przy montażu produktu przez wykwalifikowany personel fachowy należy zważać na to, by powierzchnia mocowania na całym obszarze mocowania była równa (by nie było szczelin wzgl. wzajemnie przesuniętych płytek), rodzaj ściany nadawał się do montażu produktu i zwłaszcza, by nie było żadnych słabych stron.
- Umieszczone w dostawie śruby i kołki rozporowe są przeznaczone tylko do betonu. Przy innych rodzajach montażu ścianowego należy przestrzegać danych producenta kołków rozporowych.
- Odpływ musi mieć wystarczające wymiary.
- Prysznic można podłączyć tylko po użyciu zaworu odcinającego armatury sanitarnej.

**Wskazówki dot. konserwacji**

- Działanie zabezpieczeń przed przepływem zwrotnym, zgodnie z normą DIN EN 1717 i miejscowymi przepisami, musi być kontrolowane (DIN 1988, raz w roku).

**Dane techniczne**

Ciśnienie robocze przed armaturą:	maks. 1 MPa
Zalecane ciśnienie robocze:	0,3 – 0,5 MPa
(1 MPa = 10 bary = 147 PSI)	
Temperatura wody gorącej:	maks. 60 °C
Zalecana temperatura wody gorącej:	42 °C
Blokada bezpieczeństwa:	38 °C

**Wskazówka ostrzegawcza:** Przekroczenie tej temperatury może prowadzić do oparzeń!

**Wyposażenie** (patrz strona 60)**Wymiary** (patrz strona 61)**Narzędzia do wykonania montażu** (patrz strona 60)**Przykłady montażowe**

Przykłady instalacji z podaniem ciężarów i rozmiarów przewodów, patrz od strony 62.

**Obsługa** (patrz strona 76)**Części zamienne** (patrz strona 76)**Serwisowy Wymienić żarówkę** (patrz strona 77)**Czyszczenie** (patrz strona 78)**Elektryk instalator**

Prace instalacyjne i kontrolne mogą być przeprowadzane jedynie przez wykwalifikowanego elektryka, przestrzegając przepisów z VDE 0100 część 701 i IEC 60364-7-701.



Podłączenie wody DN 20  
Ciepła woda



Otworzyć wodę



Wł. / wyt. prąd



Podłączenie wody DN 20  
Zimna woda



Zakręcić wodę



Wł. / wyt. prąd



Zawór podtynkowy



Przebieg montażu



Wyrównanie potencjału



Regulator czterodrożny Quattro



Silikon (neutralny)



Przewód zerowy

Quattro



Zawór odcinający i regulacyjny Trio  
Universal



Rurka kablowa na doprowadzenie instalacji elektrycznej



Przewód

Trio



Od • możliwe jest funkcjonowanie.



Smar



Wyłącznik różnicowoprądowy FI



Wydajność odpływu musi być wyższa niż 50 l/min.



Uwaga na gorącą powierzchnię!



Przylącze

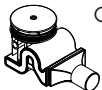

Odpływ



Nosić rękawice ochronne



Wyłącznik oświetleniowy

Raindrain



Środek brodzika



Nosić okulary ochronne



Transformator



Gąbka naturalna



Połączenia wtykowe



**Środek odkamieniający**  
(na bazie kwasu cytrynowego)

Unikać kontaktu z oczami i skórą. Jeżeli produkt dostanie się do oczu, należy je gruntownie wyplukać wodą.



Skrzynka połączeniowa



Źródło światła

**QUICK CLEAN** Funkcja QuickClean wymaga jedynie delikatnego potarcia dłonią, aby usunąć ewentualne osady kamienia wapiennego.



### Bezpečnostní pokyny

- Produkt smí být používán pouze ke koupání a za účelem tělesné hygieny.
- Děti a dospělí osoby s tělesným, duševním a / nebo smyslovým postižením nesmí produkt používat bez dozoru. Osoby pod vlivem alkoholu nebo drog nesmí produkt používat.
- Je nutné zabránit kontaktu vodních paprsků sprchy s měkkými částmi těla (např. očima). Je nutné dodržovat dostatečný odstup mezi sprchou a tělem.
- Je nutné vyrovnat velké rozdíly tlaku mezi přípoji studené a teplé vody.



### Elektrické připojení

- Elektroinstalace smí být provedena jen kvalifikovaným elektrikářem!
- Předinstalujte elektrické napájení 230V/N/PE/50Hz délka: 0,3 m
- Přívod musí být chráněn proudovým chráničem pro chybový proud (RCD/ FI) s mírným rozdílovým proudem  $\leq 30$  mA.



### Montáž základní souprava (viz strana 68)



### Montáž Vrchní sada (viz strana 73)

- **Pozor!** Armatura se musí montovat, proplachovat a testovat podle platných norem.
- Při montáži produktu kvalifikovaným odborným personálem je třeba dbát na to, aby upevňovací plochy byly v celém rozsahu upevnění rovné (žádné vyčnívající spáry nebo navzájem přesazené obklady), aby konstrukce stěny byla pro montáž produktu vhodná a zvláště aby v ní nebyla žádná slabá místa. Přiložené vruty a hmoždinky jsou vhodné pouze pro beton. Při jiných konstrukčních materiálech stěny je třeba se řídit údaji výrobce hmoždinek.
- Propustnost odpadu musí být dostatečně dimenzována.
- Sprcha smí být připojena pouze za uzavíracím ventilem sanitárního potrubí.

### Pokyny k údržbě

- U zpětných ventilů se musí podle DIN EN 1717 v souladu s národními nebo regionálními předpisy testovat jejich funkčnost (alespoň jednou ročně).

### Technické údaje

Provozní tlak před armaturou:	max. 1 MPa
Doporučený provozní tlak: (1 MPa = 10 bar = 147 PSI)	0,3 – 0,5 MPa
Teplota horké vody:	max. 60 °C
Doporučená teplota horké vody:	42 °C
Bezpečnostní zámeček:	38 °C

**Varování:** Překročení této teploty může vést k popáleninám!



### Příslušenství (viz strana 60)



### Rozměry (viz strana 61)



### Montážní nářadí (viz strana 60)



### Příklady montáže

Příklady instalace s údaji o rozměrech a dimenzování potrubí jsou uvedeny od strany 62.

### Ovládání (viz strana 76)

### Náhradní díly (viz strana 76)



### Servisní Výměna svítidel (viz strana 77)



### Čištění (viz strana 78)



### Elektroinstalatér

Instalační práce a přezkoušení musí být provedeno autorizovaným elektrotechnickým odborníkem za zohlednění směrnice VDE 0100, část 701 a IEC 60364-7-701.



Připojení vody DN 20  
Teplá voda



Vodu zapojit



Elektrický proud ZAP / VYP



Připojení vody DN 20  
Studená voda



Vodu odpojit



Elektrický proud ZAP / VYP



Podomítkový uzavírací ventil



Postup montáže



Vyrovnnání potenciálů



Quattro čtyřcestné přestavování



Silikon (bez kyseliny octové!)



Nulový vodič



Trio Universal - Uzavírací a přepínací ventil



Instalační trubka pro napájení elektrickým proudem



Vodič

**Trio**



Od • je zaručená funkce



Mazací tuk



Ochranný spínač FI



Odtokový výkon musí být vyšší než 50 l/min.

> 50 l/min



Pozor, horký povrch!



připojovací krabice



Odtok



Noste ochranné rukavice



Spínač světla

**Raindrain**

**X**

Střed sprchové vany



Noste ochranné brýle



transformátor



Přírodní mořská houba



Konektorová spojení



**Odvápňovač** (báze kyseliny citrónové)

Zabraňte styku s pokožkou a očima. Zasažne-li výrobek oči, důkladně je vypláchněte vodou.



Krabička rozdělovače



Osvětlovací prostředek

**QUICK CLEAN** S ruční čistící funkcí QuickClean stačí jednoduché odstranění vodního kamene prsty z trysek kotouče tvarujícího proud vody.



## Bezpečnostné pokyny

- Produkt sa smie používať len na kúpanie a telesnú hygienu.
- Produkt nesmú bez dozoru používať deti, ako aj dospelé osoby s telesným, duševným a/alebo zmyslovým postihnutím. Produkt nesmú používať ani osoby, ktoré sú pod vplyvom alkoholu alebo drog.
- Vyhýbajte sa kontaktu vodného lúča sprchy s citlivými miestami tela (napr. oči). Dodržiavajte dostatočnú vzdialenosť medzi sprchou a telom.
- Veľké rozdiely v tlaku medzi prípojkami studenej a teplej vody musia byť vyrovnané.



## Elektrické pripojenie

- Elektroinštalácia môže byť vykonaná len kvalifikovaným elektrikárom!
- Predinštalujte zásobovanie elektrinou 230V/N/PE/50Hz (dĺžka: 0,3 m)
- Prívod musí byť chránený prúdovým chráničom (RCD/FI) pre chybový prúd s merným rozdielovým prúdom  $\leq 30$  mA.



## Montáž základná súprava (viď strana 68)



## Montáž Vrchná sada (viď strana 73)

- **Pozor!** Armatúra sa musí montovať, preplachovať a testovať podľa platných noriem.
- Pri montáži produktu kvalifikovaným odborným personálom je nutné dbať na to, aby upevňovacie plochy boli v celom rozsahu upevnenia rovné (žiadne vyčnievajúce škáry alebo navzájom predsadené obklady), aby konštrukcia steny bola pre montáž produktu vhodná a zvlášť aby v nej neboli žiadne slabé miesta. Priložené vruty a hmoždinky sú vhodné len pre betón. Pri iných konštrukčných materiáloch steny je nutné riadiť sa údajmi výrobcu hmoždiniek.
- Prieupustnosť odpadu musí byť dostatočne dimenzovaná.
- Sprchu je možné napojiť len za uzatvárací ventil sanitárnej armatúry.

## Pokyny na údržbu

- Pri spätných ventiloch sa musí podľa DIN EN 1717 v súlade s národnými alebo regionálnymi predpismi testovať ich funkčnosť (aspoň raz ročne).

## Technické údaje

Prevádzkový tlak pred armatúrou:	max. 1 MPa
Doporučený prevádzkový tlak: (1 MPa = 10 bar = 147 PSI)	0,3 – 0,5 MPa
Teplota teplej vody:	max. 60 °C
Doporučená teplota teplej vody:	42 °C
Bezpečnostný zámok:	38 °C

**Varovanie:** Prekročenie tejto teploty môže viesť k popáleniam!



## Príslušenstvo (viď strana 60)



## Rozmery (viď strana 61)



## Montážne náradie (viď strana 60)



## Príklady montáže

Inštalčné príklady s uvedením rozmerov a výkonov nájdete od strany 62.

## Obsluha (viď strana 76)

## Náhradné diely (viď strana 76)



## Servisná Výmena svietidiel (viď strana 77)



## Čistení (viď strana 78)



## Elektroinštalatér

Inštalčné a skúšobné práce musí vykonávať len autorizovaný elektrikár pri zohľadnení noriem VDE 0100, časť 701 a IEC 60364-7-701.



Pripojenie vody DN 20  
Teplá voda



Pripojenie vody DN 20  
Studená voda



Podomietkový uzatvárací ventil



Quattro štvorcestné prestavenie

**Quattro**



Trio univerzálny uzatvárací a prestavo-  
vací ventil

**Trio**



Od • je zaručená funkcia.



Výkon odtoku musí byť vyšší ako  
50 l/min.

> 50 l/min

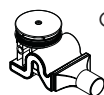

Odtok

**Raindrain**

**X**

Stred sprchovej vane



Zapojiť vodu



Odpojiť vodu



Postup montáže



Silikon (bez kyseliny octovej!)



Inštalčná rúrka elektrického napája-  
nia



Mazací tuk



Pozor, horúci vzduch!



Noste ochranné rukavice



Noste ochranné okuliare



Prírodná morská huba



**Odvápňovač** (báza kyseliny  
citrónovej)

Zabráňte styku s pokožkou a očami.  
Ak produkt zasiahne oči, dôkladne ich  
vypláchnite vodou.



Zap./vyp. prúd



Zap./vyp. prúd



Vyrovnanie potenciálov

**N**

Nulový vodič

**L**

Vodič



FI ochranný spínač



pripájacia krabica



Svetelný spínač



transformátor



Konektorové spojenia



Skrinka rozdelovača



Osvetlovací prostriedok

**QUICK CLEAN** Čistiaca funkcia QuickClean, stačí na  
jednoduché odstránenie vodného kameňa  
prstami z trysiek kotúča tvarujúceho  
prúd vody.



### 安全技巧

- 淋浴系统只允许作为洗浴、卫生和洁身之用。
- 不得让儿童和肢体、精神和/或意识有障碍的成人在不受监管的情况下使用淋浴系统。受酒精或毒品影响的人员不得使用淋浴系统。
- 必须避免让身体敏感部位（如眼睛）接触到莲蓬头喷水。必须保持莲蓬头与人头之间有足够的距离。
- 冷热水管间过大的压力差必须予以平衡。

### 技术参数

花洒接头前方的操作压力: 最大 1 MPa  
 推荐工作压强: 0,3 - 0,5 MPa  
 (1 MPa = 10 bar = 147 PSI)  
 热水温度: 最大 60 °C  
 推荐热水温度: 42 °C  
 安全止动器: 38 °C  
 警告: 温度过高会引发燃烧危险!



### 电气连接

- 电气接口只能由电气专业人员进行操作!
- 预安装供电电缆230V/N/PE/50Hz (长度 0.3米)
- 保险装置必须是额定电流 < 30 mA的故障电流保护装置。



附件 (参见第60页)



大小 (参见第61页)



装配工具 (参见第60页)



安装 基础套件 (参见第68页)



安装 加工件 (参见第73页)

- 注意! 必须按照现行的规定安装, 冲洗和测试产品。
- 在安装产品的位置, 安装人员必须确保安装面的墙面是平的 (没有突出物或瓷砖没有突起), 墙体结构适合产品的安装并没有弱点。包装内的膨胀螺丝只适用于混凝土墙体。对于其他墙体结构必须咨询膨胀螺丝生产商的建议。
- 废水管的性能必须具有充足的尺寸。
- 该莲蓬头仅允许连接在卫浴龙头的截止阀之后。

### 保养技巧

- 单向阀必须在符合国家或当地的法律的情况下按照DIN EN 1717定期检查 (至少一年一次)。



### 安装示意

带数据和管道尺寸的安装实例请从 62 页起查找。

操作 (参见第 76 页)

备件 (参见第 76 页)



备用零 更换灯具 (参见第 77 页)



清洗 (参见第 78 页)



### 电气安装人员

安装和检查工作由有资质的电气专业人员按照德国电气工程协会VDE 0100标准中第701项和国际电工委员会IEC 60364-7-701标准执行。





水连接 DN 20  
热水



水连接 DN 20  
冷水



截止阀



Quattro 四通转换器

Quattro



通用的三通截止阀和换向阀

Trio



从开始，正常功能得以保证。



排水功率必须大于 50 l/min.

> 50 l/min



排水口

Raindrain

X

中心淋浴盆



调节水



关闭水流



装配顺序



硅胶（不含醋酸）



电源线布线导管



油脂



热表面！



配戴保护手套



配戴护眼用具



天然海绵



柔软剂（柠檬酸）

避免眼睛和皮肤接触。如该产品不慎进入眼睛，立即用清水彻底冲洗。



电流 接通/断开



电流 接通/断开



电位均衡

N

零线

L

导线



FI保护开关



接线盒



照明开关



变压器



插座连接



分线盒



灯具

**QUICK CLEAN** 有了QuickClean，手工清洁功能，要去掉喷头上的水垢，只需简单地搓除即可。



### Указания по технике безопасности

- Изделие разрешается использовать только в гигиенических целях: для принятия ванны и личной гигиены.
- Дети, а также взрослые с физическими, умственными и/или сенсорными недостатками должны пользоваться изделием только под присмотром. Запрещается пользоваться изделием в состоянии алкогольного или наркотического опьянения.
- Не допускайте попадания струи воды из разбрызгивателя на чувствительные части тела (например, на глаза). Разбрызгиватель следует устанавливать на достаточном расстоянии от тела.
- донного клапа. Перед установкой смесителя необходимо регулировочными кранами выровнять авление холодной и горячей воды при помощи вентмлей регулирующих подачу воды в квартиру.



### Электроподключение

- Электрическое подключение разрешается выполнять только специалисту-электрику!
- Электропитание 230V/N/PE/50Hz (длина: 0,3 m) инсталлировать заранее.
- Требуется организовать защиту с помощью устройства защитного отключения (выключателя дифференциального тока)
- с уставкой дифференциального тока  $\leq 30$  mA.



### Монтаж Основной комплект (см. стр. 68)



### Монтаж Наружная часть (см. стр. 73)

- **Внимание!** Смеситель должен быть смонтирован по действующим нормам и в соответствии с настоящей инструкцией, проверен на герметичность и безупречность работы.
- При монтаже изделия квалифицированным персоналом необходимо следить за тем, чтобы, поверхность крепления была плоской во всей зоне крепления (без выступающих швов или смещения плитки), структура стен подходила для монтажа изделия и, в частности, не имела слабых мест. Прилагаемые винты и дюбели предназначены только для бетона. При других типах стен необходимо соблюдать указания производителей дюбелей.
- Слив должен иметь достаточную производительность.
- Источник разбрызгивания должен подсоединяться только после запорного клапана санитарной арматуры.

### Указания по техобслуживанию

- Защита обратного тока должна регулярно проверяться (минимум один раз в год) по стандарту DIN EN 1717 или в соответствии с национальными или региональными нормативами

### Технические данные

Рабочее давление в смесителе:	не более. 1 МПа
Рекомендуемое рабочее давление:	0,3 – 0,5 МПа (1 МПа = 10 bar = 147 PSI)
Температура горячей воды:	не более. 60 °C
Рекомендуемая темп. гор. воды:	42 °C
Предохранительный фиксатор:	38 °C

**Предупреждение. Превышение этой температуры может привести к ожогам!**



### Принадлежности (см. стр. 60)



### Размеры (см. стр. 61)



### Монтажный инструмент (см. стр. 60)



### варианты установки

Примеры монтажа с указанием размеров и размеры трубопровода см. на стр. 62.

### Эксплуатация (см. стр. 76)

### Запасные части (см. стр. 76)



### Гарнитурный Замена источника света (см. стр. 77)



### Очистка (см. стр. 78)



### Электрик

Установочные и проверочные работы проводятся специалистами-электриками, имеющими допуск к работе, с соблюдением VDE 0100, часть 701, и IEC 60364-7-701.



Подключение воды DN 20  
Теплая вода



откройте воду



Ток вкл. / выкл.



Подключение воды DN 20  
Холодная вода



Закройте воду



Ток вкл. / выкл.



Скрытый вентиль



Порядок монтажа



Выравнивание потенциалов



Четырехходовой переключатель  
Quattro



Силикон (не содержит уксусной кислоты!)



Нулевой провод



Трехходовой запорный и переключающий вентиль Trio Universal



Голая трубка для электропроводки



Провод



Гарантированное функционирование при показателях выше \*.



Смазка



Защитное реле FI



Слив должен иметь производительность более 50л/мин.

> 50 l/min



Осторожно! Горячая поверхность!



точка подключения

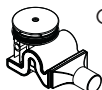

Слив

Raindrain



Носите защитные перчатки



Выключатель освещения



Середина душевой ванны



Носите средства защиты глаз



трансформатор



Губка из натурального волокна



Штекерные соединения



**Удалитель накипи**  
(на основе лимонной кислоты)  
Избегайте контакта с глазами и кожей. При попадании продукта в глаза, тщательно промойте их водой.



Распределительная коробка



Осветительное средство

**QUICK CLEAN** система QuickClean позволяет удалять известковые отложения, достаточно провести по эластичной поверхности аэратора пальцем, как известковые отложения будут удалены.



### Biztonsági utasítások

- A terméket csak fürdéshez, mosakodáshoz, és egészségügyi tisztálkodáshoz szabad használni.
- Gyermekek, valamint testileg, szellemileg fogyatékos és / vagy érzékelésben korlátozott személyek nem használhatják felügyelet nélkül a terméket. Alkohol és kábítószer befolyása alatt álló személyek nem használhatják a terméket.
- Kerülni kell a zuhanyugár érintkezését érzékeny testrészekkel (pl. szemek). Be kell tartani a megfelelő távolságot a zuhanyfej és a test között.
- A hidegvíz- és a melegvíz-csatlakozások közötti nagy nyomáskülönbséget kikell egyenlíteni!



### Elektromos csatlakozás

- Az elektromos hálózathoz való csatlakoztatást csak szakember végezheti el!
- Áramellátást 230V/N/PE/50Hz (hosszúság: 0,3 m) előre telepíteni.
- A biztosítást egy hibaáram-mentesítő (RCD/ FI) útján, egy 30 mA-nál kisebb hálózati váltóáram segítségével kell megvalósítani.



### Szerelés Alapszett (lásd a 68. oldalon)



### Szerelés A kész szerelvény (lásd a 73. oldalon)

- **Figyelem!** A csaptelepet az érvényben lévő előírásoknak megfelelően kell felszerelni, átöblíteni és ellenőrizni.
- Miközben szakképzett szakember végzi a termék felszerelését, ügyelni kell arra, hogy a rögzítési felületek a rögzítési terület teljes egészén síkok (nincsenek kiálló fugák vagy csempezélek), a fal felépítése alkalmas a termék felszereléséhez, és különösképpen, hogy nincsenek benne gyenge pontok. A mellékelt csavarok és dűbelek csak betonhoz alkalmasak. Egyéb falazatoknál figyelembe kell venni a dűbelgyártó gyártói utasításait.
- A kifolyási teljesítményt megfelelően kell dimenzionálni.
- A zuhanyt csak a szaniter csaptelep zárószelepe után szabad bekötni.

### Karbantartási utasítások

- A visszafolyásgátlók működése a DIN EN 1717 szabványnak megfelelően, a nemzeti vagy területi rendelkezésekkel összhangban, évente egyszer ellenőrizendő!

### Műszaki adatok

Üzemi nyomás a csaptelep előtt:	max. 1 MPa
Ajánlott üzemi nyomás:	0,3 – 0,5 MPa
(1 MPa = 10 bar = 147 PSI)	
Forróvíz hőmérséklet:	max. 60 °C
Forróvíz javasolt hőmérséklete:	42 °C
Biztonsági zár:	38 °C

**Figyelmeztetés:** Ezen hőmérséklet túllépése égési sérüléshez vezethet!



### Tartozék (lásd a 60. oldalon)



### Méretet (lásd a 61. oldalon)



### Szerelési szerszám (lásd a 60. oldalon)



### Szerelési példák

Felszerelési példák méretekkel és vezeték- dimenzionálással az 62 oldaltól kezdődően található.

### Használat (lásd a 76. oldalon)

### Alkatrészek (lásd a 76. oldalon)



### Szervíz Világítótest cseréje (lásd a 77. oldalon)



### Tisztítás (lásd a 78. oldalon)



### Elektromos szakember

Az installációs és ellenőrző munkákat jóváhagyott elektromos szakembernek kell elvégezni, a VDE 0100 701. része és az IEC 60364-7-701, figyelembevételével.



Vízcsatlakozás DN 20  
Melegvíz



Vízcsatlakozás DN 20  
Hidegvíz



Falsík alatti szelep



Quattro négy-utas átalakító

**Quattro**



Trio univerzális záró- és váltószelep

**Trio**



A • -től működik az adott funkció.



A lefolyó teljesítményének 50l/percnél magasabbnak kell lenni

> 50 l/min



Lefolyó

**Raindrain**

**X**

Zuhanytálca közepe



Nyissuk meg a vizet.



Zárjuk el a vizet



Szerelési sorrend



Szilikon (ecetsavmentes!)



Bergmanncső a hálózati kapcsolódás-hoz



Szilikonzsír



Vigyázat! Forró felületek!



Viseljen védkesztyűt



Viseljen szemvédőt



Természetes szivacs



**Vízkööldő** (citromsav alapú)

Kerülje a szemmel és bőrrel való érintkezést. Ha a termék a szembe jut, akkor bő vízzel mossa ki.



Áram be / ki



Áram be / ki



Potenciálkiegyenlítés

**N**

Nullavezető

**L**

Vezető



FI-védőkapcsoló



Csatlakozó doboz



Világításkapcsoló



Trafó



Dugaszoló csatlakozások



Elosztó doboz



Világítás

**QUICK CLEAN** A QuickClean manuális tisztítófunkciónak köszönhetően a vízszűrő egységek egyszerű ledörzsöléssel megtisztíthatók a vízkőtől.



### Turvallisuusohjeet

- Suihkujärjestelmää saa käyttää ainoastaan kylpy-, hygienia- ja puhdistustarkoituksiin.
- Lapset ja ruumiillisesti, henkisesti ja/tai aistillisesti rajoittuneet aikuiset eivät saa käyttää suihkujärjestelmää ilman valvontaa. Alkoholien tai huumeiden vaikutuksessa olevat henkilöt eivät saa käyttää suihkujärjestelmää.
- Suihkuveden kontaktia herkkien ruumiinosien (esim. silmien) kanssa on vältettävä. Suihkun ja vartalon välissä on oltava riittävä väli.
- Suuret paine-erot kylmä- ja kuumavesiliitäntöjen välillä on tasaettava.



### Sähköliitäntä

- Sähköliitännän saa tehdä vain sähköalan ammattilainen!
- Tehonsyöttö 230V/N/PE/50Hz (pituus: 0,3 m) esiasennetaan.
- Varmistus on tehtävä vikavirta-suojalaitetta (RCD/FI), jonka vikavirta-asetus on  $\leq 30$  mA, käyttäen.



### Asennus Perussarja (katso sivu 68)



### Asennus Valmissarja (katso sivu 73)

- **Huomio!** Kaluste on asennettava, huuhdeltava ja tarkastettava voimassa olevien määräysten mukaisesti.
- Kun pätevä ammattihenkilöstö suorittaa tuotteen asennusta, on huomioitava, että kiinnityspinta on koko kiinnityksen alueella tasainen (ei ulkonevia saumoja tai laattojen tasomuutoksia) ja, että seinän rakenne soveltuu tuotteen asentamiseen eikä siinä ole heikkoja kohtia. Mukana olevat kiinnitysruuvit ja kiinnitysankkurit soveltuvat betoniin kiinnittämiseen. Kiinnitettäessä tuotetta muihin seinärakenteisiin, noutata kiinnittimien valmistajan ohjeita.
- Poisvirtausteho on mitoitettava riittävän suureksi.
- Suihkun saa liittää vain saniteettiarmatuuriin sulkuventtiiliin.

### Huolto-ohjeita

- Vastaventtiilien toiminta on tarkastettava säännöllisesti paikallisten ja kansallisten määräysten mukaisesti (DIN 1988, kerran vuodessa).

### Tekniset tiedot

Käyttöpaine ennen kalustetta: maks. 1 MPa  
 Suositeltu käyttöpaine: 0,3 – 0,5 MPa  
 (1 MPa = 10 bar = 147 PSI)  
 Kuumen veden lämpötila: maks. 60 °C  
 Kuumen veden suosituslämpötila: 42 °C  
 Turvaestin: 38 °C  
**Varoitus:** Tämän lämpötilan ylittäminen voi aiheuttaa palovammoja!



### Varusteet (katso sivu 60)



### Mitat (katso sivu 61)



### Asennustyökalu (katso sivu 60)



### Asennusesimerkkejä

Asennusesimerkit mittoineen ja putkitietoineen löytyvät alkaen sivulta 62.

### Käyttö (katso sivu 76)

### Varaosat (katso sivu 76)



### Service Valonlähteen vaihto (katso sivu 77)



### Puhdistus (katso sivu 78)



### Sähköasentaja

Hyväksytyt sähköammattilaisen on suoritettava sähköasennus- ja tarkastustyöt VDE 0100 osa 701 ja IEC 60364-7-701 mukaisesti.



Vesiliitäntä DN 20  
Lämmin vesi



Vesiliitäntä DN 20  
Kylmä vesi



Upotettava venttiili



4-tiesäätöventtiili

**Quattro**



Trio -sulku- ja säätöventtiili

**Trio**



Tämä toiminta on taattuna • alkaen.



Poisvirtaustehon on oltava enemmän  
kuin 50 l/min.

> 50 l/min



Veden poisvirtaus

**Raindrain**

**X**

Suihkualtaan keskusta



Avaa vedensyöttö



Sulje vedentulo



Asennusjärjestys



Silikoni (etikkahappovapaa!)



Tyhjä putki virran syöttöä varten



Rasva



Varoitus kuumasta pinnasta!



Käytä suojakäsineitä



Käytä silmäsuojuksia



Luonnonsieni



**Kalkinpoistaja** (sitruunahap-  
pohjainen)

Vältä silmä- ja ihokosketusta. Jos tuotetta  
pääsee silmiin, huuhtelee silmät perus-  
teellisesti vedellä.



Sähkö päällä / pois päältä



Sähkö päällä / pois päältä



Potentialitasaus

**N**

Nollajohdin

**L**

Johdin



FI-suojakytkin



Liitäntärasia



Valokytkin



Muuntaja



Pistokeliitäntä



Jakorasia



Valonlähde

**QUICK CLEAN** QuickClean -käsitoiminen kalkin-  
poistojärjestelmä on helppo käyttää:  
hiero sormella ja vedentulo on taas  
esteetön.



### Säkerhetsanvisningar

- Produkten får bara användas till kroppshygien med bad och dusch.
- Barn samt vuxna med fysiska, psykiska eller sensoriska funktionshinder får inte använda produkten ensamma. Personer som är påverkade av alkohol- eller droger får inte använda produkten.
- Undvik att rikta duschstrålarna mot känsliga kroppsdelar (t. ex. ögonen). Det måste finnas ett tillräckligt stort avstånd mellan duschen och kroppen.
- Stora tryckskillnader mellan anslutningarna för varmt och kallt vatten måste utjämnas.



### Elektrisk anslutning

- Elanslutningen får endast utföras av en elektroinstallatör!
- Förinstallera strömförsörjning 230V/N/PE/50Hz (längd: 0,3 m).
- Säkringarna måste ske via en felströms-skyddsanordning (RCD/FI)
- med en differensström på  $\leq 30$  mA.



### Montering Grundset (se sidan 68)



### Montering Färdigset (se sidan 73)

- **OBS!** Armatyren måste installeras, genomspolas och testas enligt gällande föreskrifter.
- När kvalificerad fackpersonal monterar produkten är det viktigt att tänka på att monteringsytan är plan i alla delar av arbetsytan (inga fogar som sticker ut eller klinkerförskjutningar), att väggkonstruktionen passar till montering av produkten samt att den inte har svaga punkter. Medföljande skruvar och plugg är endast avsedda för betong. Vid andra väggkonstruktioner skall anvisningarna från pluggtillverkaren beaktas.
- Tömningskapaciteten måste vara tillräcklig.
- Duschen får bara anslutas efter en spärrventil på sanitärblandaren.

### Serviceanvisningar

- Backventilens funktion måste kontrolleras regelbundet enligt nationella eller regionala bestämmelser (DIN 1988 en gång per år) i enlighet med DIN EN 1717.

### Tekniska data

Driftstryck framför blandaren: max. 1 MPa  
 Rek. driftstryck: 0,3 – 0,5 MPa  
 (1 MPa = 10 bar = 147 PSI)  
 Varmvattentemperatur: max. 60 °C  
 Rek. varmvattentemp.: 42 °C  
 Säkerhetspörr: 38 °C  
**Varning:** om angiven temperatur överskrids kan detta leda till förbränningar!



### Tillbehör (se sidan 60)



### Måtten (se sidan 61)



### Monteringsverktyg (se sidan 60)



### Monteringsexempel

Du hittar installationsexempel med uppgifter om mått och ledningsdimensioner från sidan 62.

### Hantering (se sidan 76)

### Atsarginés dalys (se sidan 76)



### Service Byta glödlampa (se sidan 77)



### Rengöring (se sidan 78)



### Elinstallatör

Installations- och kontrollarbeten ska utföras av behörig elektroinstallatör, enligt VDE 0100 del 701 o. IEC 60364-7-701.





Vattenanslutning DN 20  
Varmvatten



Slå på vatten



Ström på / av



Vattenanslutning DN 20  
Kallvatten



Stäng av vattnet



Ström på / av



Invändig ventil



Monteringsföljd



Potentialutjämning



Quattro Fyrvägsomkastare



Silikon (fri från ättiksyra!)



Neutralledare

**Quattro**



Trio Universell avstängningsventil och omkastare



Tomledning för stömförsörjning



Ledare

**Trio**



Från • garanteras funktionen.



Fett



Jordfelsbrytare



Avloppet måste klara mer än 50l/min.



Varning för het yta!



Anslutningsdosa

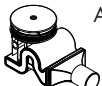

Avlopp



Bär skyddshandskar



Strömbrytare

**Raindrain**

**X**

Mitten av duschkaret



Bär ögonskydd



Transformator



Natursvamp



Stickanslutning



**Avkalkningsmedel** (citrinos  
rügšties pagrindu)

Undvik ögon- och hudkontakt. Skulle  
produkten hamna i ögonen så spola  
ur dem grundligt med vatten.



Fördelare



Glödlampa

**QUICK CLEAN** Med QuickClean, den manuella rengöringsfunktionen, är det lätt att befria strålkanalerna från kalk - de ska bar gnuggas.



### Saugumo technikos nurodymai

- Gaminys turi būti naudojamas tik maudymuisi, kūno higienai ir švarai palaikyti.
- Gaminių draudžiama naudoti vaikams, taip pat suaugusiems su fizine, dvasine negale ir (arba) sensorikos sutrikimais. Gaminių taip pat draudžiama naudoti asmenims, apsvaigusiems nuo alkoholio arba narkotikų.
- Būtina vengti dušo vandens srovės kontakto su jautriomis kūno vietomis (pvz., akimis). Todėl būtina laikytis tinkamu atstumu nuo dušo.
- Turi būti išlyginti šalto ir karšto slėgio nelygumai.



### Elektros prijungimas

- Elektrą prijungti turi elektrikas!
- Iš anksto įrengtas el. maitinimas 230V/N/PE/50Hz (ilgis 0,3 m).
- Apsauginis įrenginys (RCD / FI) apsaugo nuo nebalanso srovės, kai srovių skirtumas  $\leq 30$  mA.



### Montavimas Pagrindinis komplektas

(žr. psl. 68)



### Montavimas Virštinkinė (žr. psl. 73)

- **Dėmesio!** Maišytuvas privalo būti montuojamas ir išbandomas pagal veikiančias normas ir šią instrukciją.
- Montuojant produktą, specialistas privalo įsitikinti, kad sienos plotas, prie kurio dedama montavimo plokštė, yra lygus (jokių plytelių ar kitų nelygumų), kad sienos struktūra yra pritaikyta produkto montavimui ir neturi jokių silpnų vietų.
- Pakuotėje esantys varžtai ir kaiščiai yra skirti tik betonui. Esant kitokiai sienai, varžtus ir kaiščius reikia rinktis pagal paskirtį.
- Vandens išleidimas privalo būti pakankamo dydžio.
- Dušo galvą galima prijungti tik už vamzdyje įmontuoto uždarymo vožtuvo.

### Techninės priežiūros instrukcija

- Atbulinio vožtuvo apsauga privalo būti tikrinama reguliariai (mažiausiai kartą per metus pagal DIN 1988) pagal DIN EN1717 arba pagal galiojančias nacionalines arba regionines normas.

### Techniniai duomenys

Darbinis slėgis prieš maišytuvą: ne daugiau kaip 1 MPa  
 Rekomenduojamas slėgis: 0,3 – 0,5 MPa  
 (1 MPa = 10 barų = 147 PSI)  
 Karšto vandens temperatūra: ne daugiau kaip 60 °C  
 Rekomenduojama karšto vandens temperatūra: 42 °C  
 Apsauginė blokuotė: 38 °C  
**Įspėjimas:** dėl padidėjusios temperatūros kyla nudegimų grėsmė!



### Priedai (žr. psl. 60)



### Išmatavimai (žr. psl. 61)



### Montavimo prietaisai (žr. psl. 60)



### Montavimo pavyzdžiai

Įrengimo pavyzdžiai su nurodytais matmenimis ir vamzdyno dydžiais pateikti 62 puslapyje.

### Eksplotacija (žr. psl. 76)

### Atsarginės dalys (žr. psl. 76)



### Priežiūros Šviesos šaltinio pakeitimas

(žr. psl. 77)



### Valymas (žr. psl. 78)



### Elektromontuotojas

Instaliavimo ir tikrinimo darbus gali atlikti tik kvalifikuoti elektrikai pagal VDE 0100, 701 d. ir IEC 60364-7-701 standartų reikalavimus



Vandens prijungimas DN 20  
Šiltas vanduo



Ijunkite vandens tiekimą



Srovė įj./ išj.



Vandens prijungimas DN 20  
Šaltas vanduo



Išjungti vandens tiekimą



Srovė įj./ išj.



Potinkinis uždarymo vožtuvas



Montavimo eiga



Potencialų išlyginimas



„Quattro“ 4-krypčių perjungimas



Silikonas (be acto rūgšties!)



nulinis laidas

**Quattro**



Užtvarinis ir perjungimo vožtuvas „Trio  
Universal“



Tuščiaaviduris vamzdelis elektros aprūpinimui



laidas

**Trio**



Nuo • funkcionavimas garantuotas



Riebalai



FI apsauginis jungiklis



Nutekėjimo našumas turi būti ne mažesnis  
50 l/min



Karštas paviršius!



Prijungimo dėžutė



Nutekėjimas



Mūvėkite apsaugines pirštines



elektros jungiklis

**Raindrain**



Dušo padėklo centras



Dėvėkite akių apsaugines priemones



Transformatorius



Natūrali kempinė



kištukinės jungtys



**Nukalkintojas** (citrinos rūgšties pagrindu)

Venkite, kad produkto nepatektų į akis ir ant odos. Patekus į akis, jas kruopščiai nuplaukite vandeniu.



skirstomoji dėžutė



Šviesos šaltinis

**QUICK CLEAN** „QuickClean“ valymo funkcija apsaugo nuo apkalkėjimo. Užtenka pirštu nubraukti atsiradusius nešvarumus nuo srovės angų.



### Sigurnosne upute

- Proizvod se smije primjenjivati samo za kupanje, tuširanje i osobnu higijenu.
- Djeca, kao i tjelesno, mentalno i/ili senzorno hendikepirane odrasle osobe ne smiju se koristiti proizvodom bez nadzora. Osobe koje su pod utjecajem alkohola ili droga ne smiju se koristiti proizvodom.
- Mora se izbjegavati kontakt mlaza iz tuša s osjetljivim dijelovima tijela (npr. očima). Tijelo korisnika mora biti dovoljno udaljeno od tuša.
- Velika razlika u pritisku između vruće i hladne vode mora biti izbalansirana.



### Električni priključak

- Električnu smije priključiti samo ovlaštenu električar!
- Prethodno instalirajte električno napajanje 230V/N/PE/50Hz (duljina 0,3 m).
- Vod se mora osigurati nadstrujnom zaštitnom sklopkom (RCD/FI) s nazivnom diferencijalnom strujom  $\leq 30$  mA.



### Sastavljanje osnovna garnitura (pogledaj stranicu 68)



### Sastavljanje Završni set (pogledaj stranicu 73)

- **Pažnja!** Cijevi moraju biti postavljene, isprane i testirane prema važećim normama.
- Kada proizvod montira kvalificirano stručno osoblje treba paziti da čitava površina na koju se učvršćuje bude ravna (bez istaknutih fuga ili krivljenja pločica), da je zidna konstrukcija primjerena montaži proizvoda te osobito da nema slabih mjesta.
- Priloženi vijci i moždanici prikladni su samo za beton. Kod drugih zidnih nadgradnji treba obratiti pažnju na navode proizvođača moždanika.
- Potreban je optimalan protok vode
- Tuš se smije priključivati samo iza zapornog ventila sanitarne armature.

### Napomene za održavanje

- Ispravnost nepovratnog ventila mora se redovito provjeravati prema standardu DIN EN 1717 i u skladu sa važećim propisima (najmanje jednom godišnje).

### Tehnički podaci

Radni tlak ispred armature: tlak 1 MPa  
 Preporučeni tlak: 0,3 – 0,5 MPa  
 (1 MPa = 10 bar = 147 PSI)  
 Temperatura vruće vode: tlak 60 °C  
 Preporučena temperatura vruće vode: 42 °C  
 Sigurnosni zapor: 38 °C  
**Upozorenje:** Prekoračenje ove temperature može izazvati opekline!



### Pribor (pogledaj stranicu 60)



### Mjere (pogledaj stranicu 61)



### Alat za montažu (pogledaj stranicu 60)



### Primjeri instalacija

Primjeri instalacija s veličinama i dimenzijama vodova mogu se naći od stranice 62 nadalje.

### Upotreba (pogledaj stranicu 76)

### Rezervni dijelovi (pogledaj stranicu 76)



### Servisni Zamjena rasvjetnih tijela (pogledaj stranicu 77)



### Čišćenje (pogledaj stranicu 78)



### elektroinstalater

Električne instalacijske i ispitne radove smiju obavljati samo certificirani električari uz uvažavanje odredaba VDE 0100 dio 701 i IEC 60364-7-701.



priključak na dovod vode DN 20  
topla voda



Otvorite dotok vode



Struja uklj. / isklj.



priključak na dovod vode DN 20  
hladna voda



Zatvorite vodu



Struja uklj. / isklj.



Podžbukni ventil



Redosljed montažnih radova



Izjednačenje potencijala



Quattro četverostruki preusmjerivač



Silikon (ne sadrži kiseline)



Nulti vodič

**Quattro**



Trio Universal ventil za zatvaranje i ventil  
selektora



šuplja cijev za električno napajanje



Vodič

**Trio**



Zajamčena funkcija od • naviše



Mast



FI-sklopka



Protok vode mora biti veći od 50 l/  
min.



Upozorenje na opasnost od vrele po-  
vršine!



utičnica



Odvod



Nosite zaštitne rukavice



Prekidač za svjetlo

**Raindrain**

**X**

Sredina tuš-kada



Nosite zaštitne naočale



transformator



prirodna spužva



Utični spojevi



**Sredstvo za uklanjanje  
kamenca** (na bazi limunske  
kiseline)

Izbjegavajte kontakt s očima i kožom.  
U slučaju kontakta s očima, temeljito  
isperite s dosta vode.



Razdjelna kutija



Rasvjetno tijelo

**QUICK  
CLEAN** QuickClean - ručni sustav za čišćenje  
omogućuje jednostavnim trljanjem  
odstranjivanje kamenca sa rupica pr-  
skalice tuša.



### Güvenlik uyarıları

- Duş sistemi yalnızca banyo, hijyen ve beden temizliği amaçları doğrultusunda kullanılabilir.
- Bedensel, ruhsal ve/veya sensörük engelli çocuk ve yetişkinler gözetimsiz olarak duş sistemini kullanmamalıdır. Alkol veya uyuşturucu etkisinde olanlar duş sistemini kullanmamalıdır.
- Püskürtme başlıklarının hassas organlara teması (örn. gözler) önlenmelidir. Püskürtücü ile beden arasında yeterli mesafe bırakılmalıdır.
- Sıcak ve soğuk su bağlantıları arasında büyük basınç farklılıkları varsa, bu basınç farklılıklarının dengelenmesi gerekir.



### Elektrik bağlantısı

- Elektrik bağlantısı sadece bir elektrik teknisyeni tarafından yapılmalıdır!
- Elektrik beslemesi 230V/N/PE/50Hz (Uzunluk: 0,3 m) ön montaj.
- Emniyete alma,  $\leq 30$  mA ölçüm farkı akımı olan bir hatalı akım koruma tertibatı (RCD/FI) üzerinden gerçekleştirilmelidir.



### Montajı Ana set (Bakınız sayfa 68)



### Montajı Dışı set (Bakınız sayfa 73)

- **Önemli!** Batarya monte edilmeli, geçerli normlardan sonra akis testi yapılmalıdır.
- Müteahhit, ürünü monteleyeceği yer, yani montaj plakasının monte edileceği duvar alanının tümü düz (herhangi bir eklem yerinin ya da duvar fayansının çıkıntısıyla) engellenmemiş, yapısı ürünü montelemeye uygun bir şekilde ve herhangi zayıf noktası olamamasını sağlamalıdır.
- Kaplı vidalar ve çubuklar sadece beton için uygundur. Başka duvar yapıları için, imalatçının çubuk imal edenin belirttiği hususlar dikkate alınmalıdır.
- Çıkış kapasitesi yeterli miktarda boyutlandırılmış olmalıdır.
- Su püskürtücü yalnızca sıhhi armatürün bir kapatma vanasına bağlanabilir.

### Bakım açıklamaları

- DIN EN 1717 ve ulusal standartlar doğrultusunda Çek valfler düzenli olarak kontrol edilmelidir. ( en az yılda bir kez)

### Teknik bilgiler

Bataryadan önceki işletme basıncı azami 1 MPa  
Tavsiye edilen işletme basıncı: 0,3 - 0,5 MPa  
(1 MPa = 10 bar = 147 PSI)  
Sıcak su sıcaklığı: azami 60 °C  
Tavsiye edilen su ısı: 42 °C  
Güvenlik blokajı: 38 °C  
**Uyarı:** Bu sıcaklığın aşılması, yangınlara neden olabilir!



### Aksesuar (Bakınız sayfa 60)



### Ölçüleri (Bakınız sayfa 61)



### Montaj takımı (Bakınız sayfa 60)



### Montaj Örneği

Ölçü verileri ve hat boyutlandırıcılı tesisat örnekleri Sayfa 62 itibariyle bulunabilir.

### Kullanımı (Bakınız sayfa 76)

### Yedek parçalar (Bakınız sayfa 76)



### Servis Ampul değiştirme (Bakınız sayfa 77)



### Temizleme (Bakınız sayfa 78)



### Elektronik montajcısı

Kurulum ve kontrol çalışmaları, VDE 0100 Bölüm 701 ve IEC 60364-7-701'i dikkate almak suretiyle, elektronik konusunda uzman yetkili bir kişi tarafından gerçekleştirilmelidir.

## Türkçe



Su bağlantısı DN 20  
Sıcak su



Su bağlantısı DN 20  
Soğuk su



Sıva altı valfi



Quattro dört yönlü değiştirme

**Quattro**



Trio üniversal kapatma ve değiştirme  
valfi

**Trio**



•'den itibaren fonksiyon garanti edilmiştir.



Akış kapasitesi 50 l/dak üzerinde olmalıdır.



Akış

**Raindrain**

**X**

Duş küvetinin ortası



Suyu açın



Suyu kesin



Montaj sırası



Silikon (asetik asit içermeyen)



Akım beslemesi için boş boru



Yağ



Sıcak yüzeye karşı uyarı!



Koruyucu eldiven kullanın



Göz koruyucu kullanın



Doğal Sünger



**Kireç sökücü** (Limon asidi temeli)

Gözlere ve cilde temasından kaçının. Eğer ürün gözlere bulaşırsa, gözlerinizi su ile iyice yıkayın.



Akım açık / kapalı



Akım açık / kapalı



Potansiyel dengelemesi

**N**

Sıfır iletken

**L**

iletken

**FI**

FI koruma şalteri



Bağlantı kutusu



Işık şalteri



Trafo



Soket bağlantıları



Dağıtıcı kutu



Ampul

**QUICK CLEAN** QuickClean, üründe bulunan bir temizleme fonksiyonudur. Basit bir ovuşturma ile sprey modüllerdeki kireci çözer.

**Montajı Bakınız sayfa 68**



### Instrucțiuni de siguranță

- Sistemul de duș poate fi utilizat doar pentru spălarea, menținerea igienei și curățarea corpului.
- Copiii și adulții cu dizabilități corporale, mintale și senzoriale nu pot utiliza sistemul de duș nesupravegheați. De asemenea este interzisă utilizarea sistemului de duș de către persoane, care se află sub influența alcoolului sau a drogurilor.
- Evitați contactul jetului de apă cu părțile de corp sensibile (de ex. ochii). Țineți dușul la o distanță corespunzătoare de corp.
- Diferențele de presiune mari între alimentarea cu apă rece și apă caldă trebuie echilibrate.

### Date tehnice

Presiune de funcționare înainte de baterie:	max. 1 MPa
Presiune de funcționare recomandată:	0,3 – 0,5 MPa (1 MPa = 10 bar = 147 PSI)
Temperatura apei calde:	max. 60 °C
Temperatura recomandată a apei calde:	42 °C
Blocaj de siguranță:	38 °C

**Atenție:** depășirea acestei temperaturi poate cauza arsuri!



### Conexiune electrică

- Racordarea la rețeaua electrică poate fi efectuată numai de către un tehnician electronist specializat!
- Instalați în prealabil sistemul de alimentare cu curent 230V/N/PE/50Hz (lungime: 0,3 m).
- Instalația trebuie asigurată printr-un dispozitiv de protecție împotriva curentului rezidual (RCD/ FI)
- pentru curent rezidual măsurat de  $\leq 30$  mA.



**Accesorii** (vezi pag. 60)



**Dimensiuni** (vezi pag. 61)



**Sculă pentru montaj** (vezi pag. 60)



**Montare Set de bază** (vezi pag. 68)



**Montare Set complet** (vezi pag. 73)

- **Atenție!** Bateria trebuie montată, clătită și verificată conform normelor în vigoare.
- La montarea produsului de către un personal calificat trebuie să fiți atenți ca suprafața, unde se fixează produsul să fie plată pe toată suprafața utilizată (să nu existe rosturi sau faianțe proeminente), peretele să fie adecvat pentru montarea produsului și să nu există zone de rezistență redusă.
- Șuruburile și diblurile livrate sunt potrivite pentru ziduri de beton. La alte tipuri de zid respectați instrucțiunile producătorului diblului utilizat.
- Debitul de golire trebuie să fie suficient de mare.
- Dușul poate fi instalat doar după un robinet de închidere a armăturilor sanitare.

### Instrucțiuni de întreținere

- Supapele de reținere trebuie verificate regulat conform DIN EN 1717 și standardele naționale sau regionale (anual conform DIN 1988).



### Exemple de montare

Exemplele de montaj cu specificații referitoare la dimensiuni și capacitate se găsesc începând de la pagina 62.

**Utilizare** (vezi pag. 76)

**Piese de schimb** (vezi pag. 76)



**service Înlocuirea luminii** (vezi pag. 77)



**Curățare** (vezi pag. 78)



### Electrician

Lucrările de instalare și de verificare trebuie efectuate de către electricieni specializați, ținând cont de VDE 0100 Partea 701 și IEC 60364-7-701.





Racord de apă DN 20  
Apă caldă



Se introduce apa



Curent pornit / oprit



Racord de apă DN 20  
Apă rece



Opriți alimentarea cu apă



Curent pornit / oprit



Ventil montat sub tencuială



Ordine de montare



Egalizare de potențial



Quattro valvă de inversare cu patru  
căi



Silicon (fără acid acetic!)



Fir neutru



Trio valvă de închidere și de inversare  
universală



Tub pentru conductele de alimentare  
electrică



Conductor



Începând de la • funcționarea este  
garantată.



Unsoare



Înterupător de protecție FI



> 50 l/min

Capacitatea de evacuare trebuie să fie  
mai mare de 50 l/min.



Atenție la suprafața fierbinte!



Cutie de racord



Deversor



Purtați mănuși de protecție



Înterupător de lumină



În mijlocul căzii de duș



Purtați ochelari de protecție



Transformator



burete natural



Conexiuni



**Soluție de decalcifiere**  
(bază de acid citric)

Evitați contactul cu ochii și cu pielea. În  
cazul în care produsul ajunge în contact  
cu ochii, clățiți bine cu apă.



Cutie de distribuție



Lumină

**QUICK CLEAN** Cu ajutorul sistemului QuickClean puteți să îndepărtați depunerile de calcar de pe diferitele duze de jet de apă prin frecare.



### Υποδείξεις ασφαλείας

- Το προϊόν επιτρέπεται να χρησιμοποιείται μόνο σαν μέσο λουτρού, υγιεινής και καθαρισμού του σώματος.
- Παιδιά ή ενήλικες με μειωμένες σωματικές, διανοητικές και/ή αισθητήριες ανεπάρκειες δεν επιτρέπεται να χρησιμοποιούν το προϊόν χωρίς επίτηρηση. Άτομα υπό την επήρεια οινόπνεύματος ή ναρκωτικών δεν επιτρέπεται να χρησιμοποιούν σε καμία περίπτωση το προϊόν
- Η επαφή δέσμης νερού του ντους με ευαίσθητες περιοχές του σώματος (π.χ. μάτια) πρέπει να αποφεύγεται. Διατηρείτε επαρκή απόσταση ανάμεσα στο ντους και το σώμα.
- Οι διαφορές της πίεσης μεταξύ της σύνδεσης κρύου και ζεστού νερού θα πρέπει να αντισταθμίζονται.



### Ηλεκτρική παροχή

- Η ηλεκτρική εγκατάσταση επιτρέπεται να πραγματοποιηθεί μόνο από εξειδικευμένο ηλεκτρολόγο!
- Προεγκατάσταση παροχής ρεύματος 230V/N/PE/50Hz (Μήκος: 0,3 m).
- Η ασφάλιση θα πρέπει να πραγματοποιείται μέσω διάταξης προστασίας ρεύματος διαρροής (RCD/ FI) με παραμένον ρεύμα  $\leq 30$  mA.



### Συναρμολόγηση Βασικό σετ ( βλ. σελίδα 68 )



### Συναρμολόγηση Σετ μηχανισμού (βλ. σελίδα 73)

- **Προσοχή!** Η μπαταρία πρέπει να τοποθετηθεί, να πλυθεί και να ελεγχθεί με βάση τους ισχύοντες κανόνες υδραυλικής τέχνης
- Κατά τη συναρμολόγηση του προϊόντος από καθαρισμένο και εξειδικευμένο προσωπικό θα πρέπει να δοθεί προσοχή, ώστε η επιφάνεια στερέωσης στη συνολική περιοχή στερέωσης να είναι επίπεδη (να μην υπάρχουν προεξέχοντες αρμοί ή λιθογόμωση πλακιδίων), ώστε η κατασκευή του τοίχου να είναι κατάλληλη για τη συναρμολόγηση του προϊόντος και ώστε η επιφάνεια να μην παρουσιάζει αδύναμα σημεία.
- Οι συνημμένες βίδες και οι στυλίσκοι ενδείκνυνται μόνο για σκυρόδεμα. Σε άλλες επίτοιχες κατασκευές θα πρέπει να δοθεί προσοχή στα δεδομένα του Κατασκευαστή των στυλίσκων.
- Η κατανάλωση νερού πρέπει να έχει επαρκείς διαστάσεις.
- Το ντους επιτρέπεται να συνδέεται μόνο αφού προηγηθεί στο κύκλωμα η βαλβίδα διακοπής της μπαταρίας.

### Οδηγίες συντήρησης

- Οι βαλβίδες αντεπιστροφής πρέπει να ελέγχονται τακτικά ως προς τη λειτουργία τους, σύμφωνα με τις οδηγίες DIN EN 1717, σε σχέση με τους ισχύοντες εθνικούς ή τοπικούς κανόνες (το ελάχιστο μια φορά το χρόνο, σύμφωνα με το πρότυπο DIN 1988)

### Τεχνικά Χαρακτηριστικά

Πίεση λειτουργίας προ της βάνας:	έως 1 MPa
Συνιστώμενη λειτουργία πίεσης: (1 MPa = 10 bar = 147 PSI)	0,3 - 0,5 MPa
Θερμοκρασία ζεστού νερού:	έως 60 °C
Συνιστώμενη θερμοκρασία ζεστού νερού:	42 °C
Ασφάλεια υπερθέρμανσης νερού	38 °C

**Προειδοποίηση:** Υπέρβαση αυτής της θερμοκρασίας μπορεί να προκαλέσει εγκαύματα



### αξεσουάρ ( βλ. σελίδα 60 )



### Διαστάσεις ( βλ. σελίδα 61 )



### Εργαλεία συναρμολόγησης ( βλ. σελίδα 60 )



### Παραδείγματα συναρμολόγησης

Παραδείγματα εγκατάστασης με διαστάσεις και διαστασιολόγηση των σωλήνων θα βρείτε από τη σελίδα 62.

### Χειρισμός ( βλ. σελίδα 76)

### Ανταλλακτικά ( βλ. σελίδα 76)



### Οέρβις Αντικατάσταση φωτιστικού ( βλ. σελίδα 77)



### Καθαρισμός ( βλ. σελίδα 78)



### Ηλεκτρολόγος εγκατάστασης

Οι εργασίες εγκατάστασης και ελέγχου πρέπει να διενεργούνται από έναν εγκεκριμένο ηλεκτρολόγο, λαμβάνοντας υπόψη τις οδηγίες VDE 0100 Μέρος 701 και IEC 60364-7-701.



Παροχή νερού DN 20  
Ζεστό νερό



Παροχή νερού DN 20  
Κρύο νερό



Χωνευτή βαλβίδα



Quattro τετράοδης μετατροπής

**Quattro**



Trio Universal βαλβίδα κλεισίματος και εκτροπής

**Trio**



Αυτή η λειτουργία διασφαλίζεται από το σημείο κι έπειτα



> 50 l/min

Η αποχετευτική ικανότητα της βαλβίδας εκροής πρέπει να υπερβαίνει τα l/min.

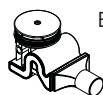

Βαλβίδα εκροής

**Raindrain**

**X**

Μέσον της ντουσιέρας



Ανοίξτε την παροχή του νερού



Κλείστε την παροχή νερού



Σειρά εργασιών συναρμολόγησης



Σιλικόνη (δίχως οξικό οξύ!)



Κενός σωλήνας για την παροχή ρεύματος



Γράσο



Προειδοποίηση: καυτή επιφάνεια!



Φοράτε γάντια προστασίας χεριών



Φοράτε γυαλιά προστασίας ματιών



Φυσικός σπόγγος



**Αποσκληρυντής νερού** (με βάση το κιτρικό οξύ)

Αποφεύγετε την επαφή με τα μάτια και το δέρμα. Σε περίπτωση που έλθει το προϊόν σε επαφή με τα μάτια ξεπλύνετε καλά με νερό.



Ρεύμα on / off



Ρεύμα on / off



Εξίσωση δυναμικού

**N**

Ουδέτερος

**L**

Αγωγός



Διακόπτης προστασίας FI



Κουτί σύνδεσης



Διακόπτης φωτισμού



Τrafo (μετασχηματιστής)



Ηλεκτρικοί συνδετήρες



Κουτί διανομής



Φωτιστικό

**QUICK CLEAN** Με QuickClean, τη λειτουργία καθαρισμού με το χέρι, μπορούν να απομακρυνθούν με απλό τρίψιμο τα άλατα από τα κανάλια του καταιονιστήρα.

**Varnostna opozorila**

- Ta izdelek se sme uporabljati le z namenom umivanja, vzdrževanja higiene in telesne nege.
- Otroci kot tudi odrasle osebe z omejenimi telesnimi, duševnimi in/ali senzoričnimi sposobnostmi ne smejo nenadzorovano uporabljati tega izdelka. Osebe, ki so pod vplivom alkohola ali drog, tega izdelka ne smejo uporabljati.
- Éviter le contact du jet de la douchette avec les parties sensibles du corps (telles par ex. que les yeux). Veiller à respecter un écart suffisant entre la douchette et le corps
- Velike razlike v tlaku med priključkom za mrzlo in priključkom za toplo vodo je potrebno izravnati.

**Električni priključek**

- Električno priključitev sme izvesti le elektrostrokovnjak!
- Najprej instalirajte oskrbo s tokom 230V/N/PE/50Hz (dolžina: 0,3 m).
- Zaščita se mora izvesti preko zaščitnega tokovnega stikala (RCD/ FI)
- z izračunanim diferenčnim tokom  $\leq 30$  mA.

**Montaža Osnovni komplet** (glejte stran 68)**Montaža Zaključna garnitura** (glejte stran 73)

- **Pozor!** Armaturo je potrebno montirati, splakniti in testirati v skladu z veljavnimi predpisi.
- Kamorkoli bo pogodbenik namestil izdelek, mora poskrbeti, da je celotno območje stene na katero bo plošča nameščena ravno (brez štrlečih fug ali robov ploščic), ter da je struktura stene primerna za namestitev in je brez šibkih točk.
- Priloženi vijaki in ležaji so primerni le za beton. Za ostale zidne konstrukcije je potrebno upoštevati proizvajalčeva navodila.
- Zmogljivost odtoka mora biti ustrezne velikosti.
- Prha se sme priključiti le za zapornim ventilom sanitetne armature.

**Navodila za vzdrževanje**

- Delovanje protipovratnega ventila je potrebno v skladu z DIN EN 1717 in skladno z državnimi in regionalnimi določili (DIN 1988 enkrat letno) redno testirati.

**Tehnični podatki**

Obratovalni tlak pred armaturo:	maks. 1 MPa
Priporočeni delovni tlak: (1 MPa = 10 bar = 147 PSI)	0,3 – 0,5 MPa
Temperatura tople vode:	maks. 60 °C
Priporočena temperatura tople vode:	42 °C
Varnostna blokada:	38 °C

**Opozorilo:** prekoračitev te temperature lahko povzroči opekline!

**Pribor** (glejte stran 60)**Mere** (glejte stran 61)**Montažno orodje** (glejte stran 60)**Primeri montaže**

Instalacijske primere z navedbami mer in dimenzioniranjem cevi najdete od strani 62 dalje.

**Upravljanje** (glejte stran 76)**Nadomestni deli** (glejte stran 76)**Servisni Zamenjava svetilke** (glejte stran 77)**Čiščenje** (glejte stran 78)**Elektroinštalater**

Instalacijo in preizkuse mora izvesti pooblaščen elektro strokovnjak, pri čemer mora upoštevati VDE 0100 Del 701 in IEC 60364-7-701.



Vodni priključek DN 20  
Topla voda



Vodni priključek DN 20  
Mrzla voda



Podometni ventil



Quattro 4tiripotna prestavitev

**Quattro**



Trio Universal zaporni in preklopni ventil

**Trio**



Od • je delovanje zagotovljeno.



Odtočna kapacitetamora znašati več kot 50 l/min.

> 50 l/min

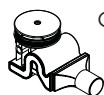

Odtok

**Raindrain**

**X**

Sredina pršne kadi



Odprite vodo



Zaprite vodo.



Montažno zaporedje



Silikon (brez očetne kisline)



Prazna cev za napajanje



Silikonska mast



Opozorilo pred vročo površino!



Nosite zaščitne rokavice



Nosite zaščito za oči



Naravna gobica



**Odstranjevalec apnenca**  
(na osnovi citronske kisline)

Izogibajte se stiku z očmi in kožo. Če proizvod pride v oči, jih temeljito sperite z vodo.



Tok vklop / izklop



Tok vklop / izklop



Potencialna izenačitev

**N**

Ničelni vodnik

**L**

Vodnik



Zaščitno tokovno stikalo



Priključnica



Stikalo za luč



transformator



Vtične povezave



Razdelilna doza



Svetilo

**QUICK CLEAN** Z QuickClean, ročno čistilno funkcijo, lahko s šob očistimo vodni kamen tako, da šobe enostavno podrgnemo.

**Ohutusjuhised**

- Toodet tohib kasutada ainult pesemis-, hügieeni- ja kehapihutamiseesmärkidel.
- Lapsed, samuti kehaliste, vaimsete või tajupiirangutega täiskasvanud ei tohi dušisüsteemi järelvalveta kasutada. Alkoholi või narkootikumide mõju all olevad isikud ei tohi dušisüsteemi kasutada.
- Duši veejoad ei tohi kokku puutuda tundlike kehaosadega (nt silmad). Jätke duši ja keha vahele piisav vahe.
- Kui külma ja kuumu vee ühenduste surve on väga erinev, tuleb need tasakaalustada.

**Elektriühendus**

- Elektriühenduse peab läbi viima väljaõppinud elektrik!
- Eelinstalleerige toide 230V/N/PE/50Hz (pikkus: 0,3 m).
- Kaitse peab toimuma rikkevoolu kaitseseadisega (RCD/FI) minimaaljäakvooluga  $\leq 30$  mA.

**Paigaldamine põhikomplekt** (vt lk 68)**Paigaldamine Valmiskomplekt** (vt lk 73)

- **Tähelepanu!** Seadmestiku paigaldamine, läbipesu ja kontrollimine peab toimuma vastavalt kehtivatele normidele.
- Toote paigaldamisel peab töövõtja tagama, et kogu seinapind, kuhu paigaldusplaat kinnitatakse, on lame (ükski vuuk ega keramiline plaat ei ulatu esile), ning et seina konstruktsioon on toote paigaldamiseks sobiv ja sellel puuduvad nõrgad kohad.
- Kaasasolevad kruvid ja tüüblid sobivad üksnes betoonile. Muude seinakonstruktsioonide puhul tuleb arvesse võtta tüüblitootja esitatud tooteandmeid.
- 
- Äravoolu jõudlus peab olema piisav.
- Duši tohib ühendada ainult sanitaaramatuuri sulgurkraanile.

**Hooldusjuhised**

- Tagasilöögiklappide toimimist tuleb kooskõlas riiklike ja regionaalsete määrustega regulaarselt kontrollida vastavalt standardile DIN EN 1717 (DIN 1988 - kord aastas).

**Tehnilised andmed**

töörõhk süsteemis enne duši:	maks. 1 MPa
Soovitatav töörõhk:	0,3 – 0,5 MPa
(1 MPa = 10 baari = 147 PSI)	
Kuumu vee temperatuur:	maks. 60 °C
Soovitatav kuumu vee temperatuur:	42 °C
Kaitselukk:	38 °C

**Hoiatus:** selle temperatuuri ületamisel võivad tekkida põletused!

**Lisavarustus** (vt lk 60)**Mõõtude** (vt lk 61)**Monteerimistööriist** (vt lk 60)**Paigalduse näited**

Paigaldusnäited koos mõõtude info ja voolikute suurustega leiate alates leheküljest 62.

**Kasutamine** (vt lk 76)**Varuosad** (vt lk 76)**Varuos Lambi vahetamine** (vt lk 77)**Puhastamine** (vt lk 78)**Elektrimontöör**

Paigaldustööd ja kontroll laske viia läbi sertifitseeritud spetsialistil vastavalt VDE 0100 osa 701 ja IEC 60364-7-701 eeskirjadele.



Veeühendus DN 20  
Soe vesi



Veeühendus DN 20  
Külm vesi



peiteklapp



Quattro-liitmik

**Quattro**



Katkestus- ja ümberlülitusklapp Trio  
Universal

**Trio**



Alates • on funktsioneerimine garanteeritud



Äravoolu jõudlus peab olema suurem kui 50 l/min.



Äravool

**Raindrain**



Dušivanni kese



Keerake vesi lahti



Keerake vesi kinni



Montaažijärjestus



Silikoon (äädikhappeta!)



elektrivarustus juhtmestiku paigaldus



Määre



Kuum pealispind!



Kandke kaitsekindaid



Kandke kaitseprille



Looduslik svamm



**Katlakivi eemaldaja** (põhib sidrunhappel)

Vältige kokkupuudet silmade ja nahaga. Kui toode satub silma, siis loputage silmi hoolikalt veega..



Elektrivool sees / väljas



Elektrivool sees / väljas



Potentsiaali tasakaalustamine



neutraaljuhe



juhe



kaitse



harukarp



valguslüüti



Trafo



pistikühendused



harukarp



Valgusti

**QUICK CLEAN** Käsitsi puhastamise funktsiooni QuickClean puhul on vajalik vaid kerge ülehõõrumine, eemaldamiseks dušikanalitest katlakivi.



### Drošības norādes

- Šo produktu drīkst izmantot tikai, lai mazgātos, higiēnai un ķermeņa tīrīšanai.
- Bērni, kā arī pieaugušie ar fiziskiem, garīgiem un / vai sensoriskiem ierobežojumiem nedrīkst lietot šo produktu bez uzraudzības. Personas, kas atrodas alkohola vai narkotisko vielu iespaidā, nedrīkst lietot šo dušas sistēmu.
- Nepieciešams izvairīties no dušas strūkļas tieša kontakta ar jutīgām ķermeņa daļām (piem., acīm). Nepieciešams ievērot pietiekošu attālumu starp dušu un ķermeni.
- Jāizlīdzina spiediena atšķirības starp aukstā un karstā ūdens pievadiem.



### Elektroapgādes pieslēgvietā

- Elektrisko pieslēgumu drīkst veikt tikai elektriķis!
- Iepriekš instalējiet elektroapgādi 230V/N/PE/50Hz (garums: 0,3 m).
- Jānodrošina noplūdes strāvas aizsargsistēma (RCD/ FI) ar izmērīto strāvas stiprumu ≤ 30 mA.



### Montāža Pamatkomplekts (skat. 68. lpp.)



### Montāža Komplekts (skat. 73. lpp.)

- **Uzmanību!** Jaucējkrāns jāmontē, jāskalo un jāpārbauda atbilstoši spēkā esošajām normām.
- Ja izstrādājuma montāžu veic kvalificēti speciālisti, jāseko, lai nostiprināšanas virsma visā nostiprināšanas zonā būtu gluda (šuves un flīzes nav izvirzītas uz āru), lai sienas konstrukcija būtu piemērota izstrādājuma montāžai un būtu pietiekami izturīga.
- Komplektā esošās skrūves un dībeļi ir paredzēti tikai šī izstrādājuma nostiprināšanai.
- Ja sienas konstrukcija ir citāda, jāievēro
- dībeļu ražotāja norādījumi.
- Noplūdei jānodrošina pietiekama ūdens caurplūde.
- Dušu drīkst pieslēgt vienīgi aiz sanitārās armatūras noslēgšanas vārsta.

### Norādes tehniskajai apkopei

- Regulāri jāpārbauda pretvārsta funkcija saskaņā ar DIN EN 1717 saistībā ar nacionālajiem vai vietējiem noteikumiem (DIN 1988 vienreiz gadā).

### Tehniskie dati

Darba spiediens pirms jaucējkrāna: maks. 1 MPa  
 Ieteicamais darba spiediens: 0,3 – 0,5 MPa  
 (1 MPa = 10 bar = 147 PSI)  
 Karstā ūdens temperatūra: maks. 60 °C  
 Ieteicamā karstā ūdens temperatūra: 42 °C  
 droša temperatūra 38 °C  
**Bīdinājums:** šīs temperatūras pārsniegšana var izraisīt applaucēšanos!



### Aksesuāri (skat. 60. lpp.)



### Izmērus (skat. 61. lpp.)



### Montāžas instruments (skat. 60. lpp.)



### Montāžas piemēri

Uzstādīšanas piemēri ar izmēriem un vadu izkārtojumu atrodami, sākot no 62 lappuses.

### Lietošana (skat. 76. lpp.)

### Rezerves daļas (skat. 76. lpp.)



### Apkopes Apgaismes ķermeņa nomaiņa (skat. 77. lpp.)



### Tīrīšana (skat. 78. lpp.)



### Elektromontieris

Instalācijas un pārbaudes darbus jāveic sertificētam speciālistam saskaņā ar DIN VDE 0100 701. d. un IEC 60364-7-701.





Ūdensvada pieslēgvietā DN 20  
Siltais ūdens



Atgrieziet ūdeni



Strāva ieslēgta / izslēgta



Ūdensvada pieslēgvietā DN 20  
Aukstais ūdens



Noslēgt ūdeni



Strāva ieslēgta / izslēgta



Zemapmetuma ventīlis



Montāžas secība



Potenciāla izlīdzināšana



Četrvirzienu pārslēgs



Silikons (etiķskābi nesaturošs!)



nulles vads



**Quattro**

Trīsvirzienu universālais noslēgvārsts un  
pārslēdzējvārsts



Caurule strāvas padevei



vads



**Trio**



No • funkcija nodrošināta



Ziede



drošinātājs



Noteces veikspējai jābūt vairāk nekā  
50 l/min.

> 50 l/min



Bīdīnājums par karstu virsmu!



Pieslēguma rozete



Notece

**Raindrain**



Valkāt aizsargcimdus



gaismas slēdzis



Dušas paliktņa vidus



Valkāt acu aizsargus



Transformators



Dabīgais sūklis



spraudkontakti



**Atkalķotājs** (uz citronskābes  
bāzes)

Novērst nokļūšanu acīs un uz ādas. Ja  
produkts iekļūst acīs, tās kārtīgi jāskalo  
ar ūdeni.



sadales kārba



Apgaismes ķermenis

**QUICK CLEAN** QuickClean attīrīšanas funkcija - strūklas kanāliņi vienkāršas manuālas berzes rezultātā tiek attīrīti no kaļķa.



### Sigurnosne napomene

- Proizvod sme da se koristi samo za kupanje, tuširanje i ličnu higijenu.
- Deca, kao i telesno, mentalno i/ili senzorno hendikepirane odrasle osobe ne smeju da koriste proizvod bez nadzora. Osobe koje su pod uticajem alkohola ili droga ne smeju da koriste proizvod.
- Mora se izbegavati kontakt mlaza iz tuša sa osetljivim delovima tela (npr. očima). Telo korisnika mora biti na dovoljnom odstojanju od tuša.
- Velika razlika u pritisku između vruće i hladne vode mora biti izbalansirana.



### Električni priključak

- Električnu sme priključiti samo ovlašćeni električar!
- Prethodno instalirajte električno napajanje 230V/N/PE/50Hz (dužina: 0,3 m).
- Vod se mora osigurati nadstrujnom zaštitnom sklopkom (RCD/FI) s nazivnom diferencijalnom strujom  $\leq 30$  mA.



### Montaža osnovna garnitura (vidi stranu 68)



### Montaža Završni set (vidi stranu 73)

- **Pažnja!** Armatura mora biti postavljena, isprana i testirana prema važećim normama.
- Kada proizvod montira kvalifikovano stručno osoblje treba paziti da čitava površina na koju se učvršćuje bude ravna (bez istaknutih fuga ili krivljenja pločica), da je zidna konstrukcija primerena montaži proizvoda, i posebno da nema slabih mesta.
- Priloženi zavrtnji i tiplovi prikladni su samo za beton. Kod drugih zidnih nadgradnji treba obratiti pažnju na navode proizvođača tiplova.
- Mora se predvideti dovoljan kapacitet odvoda.
- Tuš se sme priključivati samo iza ventila za zatvaranje sanitarne armature.

### Napomene za održavanje

- Ispravno funkcionisanje nepovratnog ventila se mora redovno proveravati prema standardu DIN EN 1717 i u skladu s važećim nacionalnim ili regionalnim propisima (DIN 1988 jednom godišnje).

### Tehnički podaci

Radni pritisak ispred armature:	maks. 1 MPa
Preporučeni radni pritisak: (1 MPa = 10 bar = 147 PSI)	0,3 – 0,5 MPa
Temperatura vruće vode:	maks. 60 °C
Preporučena temperatura vruće vode:	42 °C
Sigurnosni prekid:	38 °C

**Upozorenje:** Prekoračenje ove temperature može da izazove opekotine!



### Pribor (vidi stranu 60)



### Mere (vidi stranu 61)



### Montažni alat (vidi stranu 60)



### Primeri montaže

Primeri instalacija sa veličinama i dimenzijama vodova mogu se naći od stranice 62 nadalje.

### Rukovanje (vidi stranu 76)

### Rezervni delovi (vidi stranu 76)



### Servisni Zamena svetiljki Zamena svetiljki (vidi stranu 77)



### Čišćenje (vidi stranu 78)



### elektroinstalater

Instalaciju i ispitivanje smeju obavljati isključivo sertifikovani električari uz uvažavanje odredaba VDE 0100 deo 701 i IEC 60364-7-701.



priključak za vodu DN 20  
topla voda



priključak za vodu DN 20  
hladna voda



Uzidni ventil



Quattro četvorostruki preusmerivač

**Quattro**



Trio Universal ventil za zatvaranje i pre-  
klopni ventil

**Trio**



Od • je funkcija zagarantovana.



Kapacitet odvoda mora biti veći od 50  
l/min.

> 50 l/min

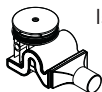

Ispust

**Raindrain**

**X**

Sredina tuš-kada



Otvorite dotok vode



Zatvorite dotok vode



Redosled montažnih radova



Silikon (ne sadrži sirćetnu kiselinu!)



Šuplja cev za električno napajanje



Mast



Upozorenje na opasnost od vrele po-  
vršine!



Nosite zaštitne rukavice



Nosite zaštitne naočare



prirodni sunder



**Sredstvo za uklanjanje  
kamenca** (na bazi limunske  
kiseline)

Izbegavajte kontakt sa očima i kožom.  
U slučaju kontakta sa očima, dobro is-  
perite sa dosta vode.



Struja uklj. / isklj.



Struja uklj. / isklj.



Izjednačenje potencijala

**N**

Nulti provodnik

**L**

Provodnik



FI-sklopka



utičnica



Prekidač za svetlo



transformator



Utični spojevi



Razvodna kutija



Svetiljka

**QUICK  
CLEAN** QuickClean - ručni sistem za čišćenje  
omogućuje odstranjivanje kamenca s  
rupica uobličavača mlaza, jednostav-  
nim trljanjem.



### Sikkerhetshenvisninger

- Dusjsystemet skal kun brukes for bade-, hygiene- og kroppshygiene.
- Barn og voksne med fysiske og psykiske og/eller sensoriske handicap skal ikke bruke dusjsystemet uten oppsyn. Personer som er påvirket av alkohol eller narkotika skal ikke bruke dusjsystemet.
- Dusjstrålen skal ikke komme i kontakt med ømfintlige kroppsdeler (f.eks. øynene). Overhold en tilstrekkelig avstand mellom dusjen og kroppen.
- Store trykkdifferanser mellom kaldt- og varmtvannstilkoblinger skal utlignes.



### El-tilkoblinger

- El-tilkoblinger skal kun utføres av el-fagfolk!
- Strømforsyning 230V/N/PE/Hz (lengde: 0,3 m) installeres på forhånd.
- Installasjonen skal sikres ved hjelp av en jordfeilbryter (RCD/FI) dimensjonert for en reststrøm på  $\leq 30$  mA.



### Montasje Basissett (se side 68)



### Montasje Ferdigsett (se side 73)

- **Obs!** Armaturen skal monteres, spyles og sjekkes iht. gyldige standarder.
- Når kvalifisert fagfolk monterer produktet, skal man påse at hele området der produktet monteres er plant (ingen fremstående fuger eller flisekanter), at oppbygging av veggen er egnet for montasje av produktet og at veggen ikke viser noen svakheter. Medleverte skruer og plugg er egner seg kun for betong. Ved en annen veggoppbygging skal man ta hensyn til pluggproducentens henvisninger.
- Utløpsytelsen skal være tilstrekkelig dimensjonert.
- Dusjen skal kun monteres etter en avstengingsventil til sanitærarmaturen.

### Vedlikeholdsanvisning

- Funksjonen til returløpssperren skal iht. DIN EN 1717 og i samsvar med de nasjonale og lokale forskrifter sjekkes regelmessig (DIN 1988 en gang i året).

### Tekniske data

Driftstrykk før armatur: maks. 1 MPa  
 Anbefalt driftstrykk: 0,3 – 0,5 MPa  
 (1 MPa = 10 bar = 147 PSI)  
 Varmtvannstemperatur maks. 60 °C  
 Anbefalt temperatur for varmt vann 42 °C  
 Sikkerhetssperre 38 °C

**Varselshenvisning:** Overskridelse av denne temperaturen kan medføre forbrenninger!



### Tilbehør (se side 60)



### Mål (se side 61)



### Montasje verktøy (se side 60)



### Montasje-eksempel

Installasjonseksempel med målangivelser og ledningsdimensjoner finns fom. side 62.

### Betjening (se side 76)

### Reservedeler (se side 76)



### Service Bytte lysmiddel (se side 77)



(se side 77) (se side 78)



### El-installatør

Installasjons- og kontrollarbeid skal utføres av en godkjent el-fagbedrift som overholder direktiv VDE 0100 del 701 og IEC 60364-7-70101.



Vanntilkobling DN 20  
Varmtvann



Vanntilkobling DN 20  
Kaldtvann



Innfelt ventil



Quattro fire-veis omstilling

**Quattro**



Trio universal stenge- og omstillings-  
ventil

**Trio**



F.o.m. • er funksjonen garantert



> 50 l/min

Avløp ytelse skal være mer enn 50 l/  
min.

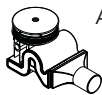

Avløp

**Raindrain**



Midten på dusjkar



Vann settes på



Slå av vann



Montasje rekkefølge



Silikon (uten eddiksyre)



Tomme rør for strømforsyning



Fett



Varsel pga. het overflate!



Bruk vernehansker



Bruk vernebriller



Natursvamp



**Avkalker** (sitronsyrebasert)

Unngå øye- og hudkontakt. Hvis produk-  
tet skulle komme i kontakt med øynene,  
skyll dem grundig med vann.



Strøm på / av



Strøm på / av



Potensialutjevning



Nulleleder



Leder



FI-vernebryter



Koblingskontakt



Lysbryter



Transformator



Pluggforbindelse



Fordelerboks



Lysmiddel

**QUICK CLEAN** Med Quiclean, den manuelle rengjø-  
ringsfunksjonen, kan stråleformere  
renses for kalk ved hjelp av enkel gnik-  
king.



### Указания за безопасност

- Позволено е използването на продукта само за къпане, хигиена и цели на почистване на тялото.
- Не е позволено деца, както и възрастни с физически, умствени и / или сензорни ограничения да използват продукта без надзор. Не е позволено използването на системата на продукта от лица, употребили алкохол или дрога.
- Трябва да се избягва контакта на струите на разпръсквателя с чувствителни части на тялото (напр. очите). Между разпръсквателя и тялото трябва да се спазва достатъчно разстояние.
- Големите разлики в налягането между изходите за студената и топлата вода трябва да се изравняват.



### Свързване към електричеството

- Свързването към електричество се позволява само от електротехник!
- Захранване с ток 230V/N/PE/50Hz (дължина: 0,3 м).
- Защитата трябва да се осъществи с предпазен шалтер за остатъчен ток (RCD/ FI) с параметриран диференциален ток  $\leq 30$  mA.



### Монтаж Основен набор (вижте стр. 68)



### Монтаж Готов набор (вижте стр. 73)

- **Внимание!** Арматурата трябва да се монтира, промие и провери в съответствие с валидните норми.
- При монтаж на продукта от квалифицирани специалисти да се внимава за това, закрепващата повърхност в целия диапазон на закрепването да бъде равна (без изпъкнали фуги или изместване на плочки), конструкцията на стената да е подходяща за монтаж на продукта и особено за това, да няма слаби места. Приложените винтове и дюбели са подходящи само за бетон. При други стени конструкции да се спазват данните на производителя на дюбели.
- Трябва да се изчисли достатъчна мощност на изтичане.
- Разпръсквателят може да се свърже само след спирачен клапан на санитарната арматура.

### Указания за поддръжка

- Съгласно DIN EN 1717 редовно трябва да се проверява функционирането на приспособленията за предотвратяване на обратния поток в съответствие с националните или регионални изисквания (DIN 1988 веднъж годишно).

### Технически данни

Работно налягане преди арматурата:	макс. 1 МПа
Препоръчително работно налягане:	0,3 – 0,5 МПа (1 МПа = 10 bar = 147 PSI)
Температура на горещата вода:	макс. 60 °C
Препоръчителна температура на горещата вода:	42 °C
Предпазна блокировка:	38 °C

**Предупредително указание:** Надвишаването на температурата може да доведе до изгаряния!



### Принадлежности (вижте стр. 60)



### Размери (вижте стр. 61)



### Монтажни инструменти (вижте стр. 60)



### Примери за монтаж

Примери за инсталация с данни за размери и определяне на размерите на тръбопроводите можете да намерите от стр. 62 нататък.

### Обслужване (вижте стр. 76)

### Резервни части (вижте стр. 76)



### Сервиз Смяна на осветителното тяло (вижте стр. 77)



### Почистване Почистване (вижте стр. 78)



### Електромонтьор

Дейностите по инсталацията и инспекцията следва да бъдат изпълнявани от оторизиран електротехник при спазване на VDE 0100 Част 701 и IEC 60364-7-701.



Извод за вода DN 20  
Топла вода



Извод за вода DN 20  
Студена вода



Клапан за мазилка



Четирипътно превключване Quattro

**Quattro**



Спирателен и превключващ клапан  
Trio Universal

**Trio**



От • функцията е гарантирана.



Мощността на изтичане трябва да  
бъде повече от 50 л/мин.

> 50 l/min



Отвеждане

**Raindrain**

**X**

Среда на коритото на душ-кабината



Включване на водата



Изключване на водата



Последователност на монтажа



Силикон (без оцетна киселина!)



Тръба за полагане на кабели за елек-  
трозахранване



грес



Предупреждение за гореща повърх-  
ност!



Носете защитни ръкавици



Носете защита за очите



Естествен сунгер



**Препарат за почистване  
на варовик** (на базата на  
лимонова киселина)

Избягвайте контакт с очите и кожата.  
Ако продуктът попадне в очите Ви,  
изплакнете ги добре с вода.



Електричество вкл / изкл



Електричество вкл / изкл



Изравняване на потенциала

**N**

Нулев проводник

**L**

Проводник



Защитен прекъсвач погрешен ток



Присъединителна кутия



Прекъсвач за осветлението



Трансформатор



Щепселни съединения



Разпределителна кутия



Осветително тяло

**QUICK  
CLEAN** С QuickClean, ръчната функция за почистване, приспособленията за оформяне на струята могат да се почистват от варовика с просто разтъркване.



## Udhëzime sigurie

- Produkti duhet të përdoret vetëm qëllimet e banjave, të higjienës dhe të larges së trupit.
- Fëmijët dhe të rriturit me aftësi të kufizuara fizike, mendore dhe/ose ndijuese nuk duhet ta përdorin produktin pa qenë nën mbikëqyrje. Personat që janë nën ndikimin e drogave ose të alkoolit nuk duhet ta përdorin produktin.
- Kontakti i valëve të dushit me pjesët e ndjeshme të trupit (p.sh. me sytë) duhet që të shmanget. Midis dushit dhe trupit duhet që të mbahet një distancë e mjaftueshme.
- Ndryshimet e mëdha të presionit mes lidhjeve të ujit të ftohtë dhe atij të ngrohtë duhen ekuilibruar.



## Lidhja me rrjetin elektrik

- Lidhjet elektrike mund të bëhen vetëm nga elektricisti i specializuar.
- Instaloni paraprakisht ushqimin elektrik 230V/N/PE/50Hz (gjatësia 0,3 m).
- Sigurimi duhet të kryhet nëpërmjet një pajisjeje mbrojtëse kundër rrjedhjes së rrymës (RCD/ FI) me një vlerësim të rrymës diferenciale  $\leq 30\text{mA}$ .



## Montimi Komplet i bazë (shih faqen 68)



## Montimi Komplet i gatshëm (shih faqen 73)

- **Kujdes!** Armatura duhet montuar, shpërlarë dhe kontrolluar në bazë të normave të vlefshme.
- Gjatë montimit të produktit nga ana e personit të kualifikuar duhet pasur parasysh që e gjithë sipërfaqja mbërthyesë të jetë e drejtë (nuk duhet të ketë hapësira mes pllakave). Mbi të gjitha muri duhet të jetë i përshtatshëm për montim dhe nuk duhet të ketë pika të dobëta. Vidhat dhe kunjat e bashkangjitura janë të përshtatshme vetëm për beton. Te përbërja tjetër murore të merren parasysh të dhënat e prodhuesit të kunjave.
- Kapaciteti i rrjedhjes duhet dimensionuar në mënyrë të mjaftueshme.
- Dushi duhet të jetë i lidhur vetëm pas një valvule bllokuese të pajisjes sanitare.

## Udhëzime për mirëmbajtjen

- Penguesit e rrjedhjes në drejtim të kundërt duhen kontrolluar rregullisht në bazë të normave DIN EN 1717 konform normave nacionale dhe regjionale (DIN 1988 një herë në vit).

## Të dhëna teknike

Shtypja para armaturës:	maks. 1 MPa
Presioni i rekomanduar: (1 MPa = 10 bar = 147 PSI)	0,3 – 0,5 MPa
Temperatura e ujit të ngrohtë	maks. 60 °C
Temperatura e rekomanduar e ujit të ngrohtë:	42 °C
Blokada e sigurisë	38 °C

**Paralajmërim Tejkalimi i kësaj temperature mund të shkaktojë djegie!**



## Pajisje shtesë (shih faqen 60)



## Përmasat (shih faqen 61)



## Vegla e montimit (shih faqen 60)



## Shembuj të montimit

Shembujt e instalimit me përmasat dhe dimensionimet e tubacioneve mund t'i gjeni nga faqja 62.

## Përdorimi (shih faqen 76)

## Pjesët e këmbimit (shih faqen 76)



## Servisi Ndërrimi i llambës (shih faqen 77)



## Pastrimi (shih faqen 78)



## (shih faqen 78)

Punimet e instalimit dhe të kontrollit duhet të realizohen nga një elektrikist i autorizuar duke marrë parasysh VDE 0100 Pjesa 701 dhe standardin IEC 60364-7-701.



## Shqip



Lidhja me rrjetin e ujit DN 20  
Uji i ngrohtë



Hapni ujin



Korrenti kyçur / shkyçur



Lidhja me rrjetin e ujit DN 20  
Uji i ftohtë



Mbyllni ujin.



Korrenti kyçur / shkyçur



Ventili i suvajës



Radha e montimit



Barazimi i potencialeve



Valvul devijuese Quattro me katër drejtime

**Quattro**



Silikon (pa acid uthulle!)



Lidhja neutrale



Valvul universale Trio për bllokim dhe devijim

**Trio**



Tubi bosh për furnizimin me energji elektrike



Lidhje



Nga • është i mundur funksioni.



Graso



Çelësi mbrojtës FI



Kapaciteti i shkarkimit duhet të jetë më shumë se 50 l/minutë.

> 50 l/min



Paralajmërimi për sipërfaqen e nxehtë!



Kutia lidhëse

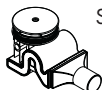

Shkarkimi

**Raindrain**



Vendosni doreza mbrojtëse



Çelësi i dritës



Mesi i vaskës së dushit



Vendosni mbrojtëse për sytë



Trafo



Sfungjer natyral



Lidhjet e prizave



**Largues bigorri** (me bazë acidi citrik)

Shmangni kontaktin me sytë dhe lëkurën. Nëse produkti bie në kontakt me sytë, shpëlaqini ato mirë me ujë të bollshëm.



Kutia shpërndarëse



Ndriçuesi

**QUICK CLEAN** Me QuickCleanit®, funksionin manual të pastrimit mund të hiqen mbetjet gëlqerore me fërkim të thjeshtë nga formuesit e currilit.

تشغيل/ إيقاف الكهرباء		افتح خلاط المياه.		توصيلة مياه DN 20 ماء دافئ	
تشغيل/ إيقاف الكهرباء		قم بإيقاف المياه		توصيلة مياه DN 20 ماء بارد	
معدلة الجهد الكهربائي		ترتيب التركيب		صمام التدفق	
الموصل المحايد	<b>N</b>	سيليكون (خالي من حمض الخليك!)		تغيير مسار رباعي كواترو	
موصل	<b>L</b>	أنبوب أسلاك لكابلات التيار		صمام حجز وتغيير تريبو يونيفرسال	
مفتاح حماية FI		شمع		من • الوظيفة مضمونة.	
نقطة التوصيل		سطح ساخن!		يجب أن تكون قدرة الصرف أكبر من 50 لتر/دقيقة	
مفتاح إضاءة		يجب ارتداء قفازات الحماية		تصريف	
محول		يجب ارتداء تجهيزات حماية العين		بانبيو مزود بدش في المنتصف	
توصيلات قابسية		إسفنجة طبيعية			
صندوق توزيع		مزيل تكلس (بحامض الليمون)			
مادة إضاءة		يجب تجنب ملامسة المنتج للعين والجلد. وفي حالة ملامسة المنتج للعين يجب غسلها جيداً بالماء.			

وباستخدام برنامج التنظيف "QuickClean" الذي يتميز بخاصية التنظيف الآلي، يمكن تنظيف وحدات دفع المياه من الجير عن طريق حكها برفق.

**QUICK CLEAN**

### المواصفات الفنية

الحد الأقصى 1 ميغاباسكال  
0,3 – 0,5 ميغاباسكال  
الحد الأقصى 60 °C  
42 °C  
38 °C  
ضغط التشغيل على تجهيزات الدش:  
ضغط التشغيل الموصى به:  
(1 ميغاباسكال = 10 بار = PSI 147)  
درجة حرارة الماء الساخن:  
درجة الحرارة الموصى بها للماء الساخن:  
حفظ أمان  
تحذير: يمكن أن يؤدي تخطي درجة الحرارة هذه إلى إحتراقات!

مكملات (راجع صفحة 60)



أبعاد (راجع صفحة 61)



أداة تركيب (راجع صفحة 60)



مثال على التركيب



يوجد بدءاً من صفحة 62 أمثلة للتركيب بمقاسات وطرق عمل بعض الوصلات.

التشغيل (راجع صفحة 76)

قطعة غيار (راجع صفحة 76)

الصيانة إستبدال وسيلة الإضاءة (راجع صفحة 77)



التنظيف (راجع صفحة 78)



مختص تركيب الإلكترونيات



يتعين القيام بكافة أعمال التركيب والفحص من قبل فني كهرباء معتمد مع الأخذ في الاعتبار الالتزام بالمعيار VDE 0100 الجزء 701 و-IEC 60364-7-701.

### تنبيهات الأمان



- لا يجب استخدام نظام الدش إلا في أغراض الاستحمام والأغراض الصحية وأغراض تنظيف الجسم.
- لا يسمح لأي أطفال أو أفراد بالغين يعانون من إعاقات بدنية أو ذهنية أو حسية أو يعانون من جميع هذه الإعاقات باستخدام المنتج إلا تحت إشراف آخرين. كما أنه لا يسمح لأي شخص تحت تأثير تناول الكحول أو المخدرات باستخدام نظام الدش.
- يجب تجنب حدوث إتصال مباشر بين الماء الخارج من رأس الدش وبين أجزاء الجسم الحساسة (مثل العينين). يجب وجود مسافة كافية بين رأس الدش والجسم.
- يجب أن يكون تيار الماء الساخن والماء البارد متعادلين في الضغط.

### توصيلة كهربائية



- لا يجوز القيام بالتوصيلات الكهربائية إلا عن طريق فني كهرباء متخصص!
- ضبط إمداد الطاقة مقدماً 230V/N/PE/50Hz (الطول 0,3 م)
- يتم التأمين من خلال تجهيزة حماية ضد اختلاف التيار (RCD/ FI) عند اختلاف التيار لأقل من أو يساوي 30 مللي أمبير.

التركيب المجموعة الرئيسية (راجع صفحة 68)



التركيب مجموعة كاملة. (راجع صفحة 73)



- هام! يجب تركيب الوصلة واستخدامها واختبارها وفقاً للمعايير المعمول بها.
- يجب الانتباه عند تركيب المنتج بواسطة فريق العمل المتخصص إلى أن جميع مواضع التثبيت جاهزة للتثبيت دون عوائق (خالية من المفصلات أو المصقات)، وأن الحائط جاهز لتركيب المنتج مع عدم احتوائه على أية أماكن ضعيفة. مبيبات المسامير (الفيشر) والمسامير نفسها مناسبة للحوائط الخرسانية فقط، ويجب الالتزام بتعليمات الجهة المصنعة لمبيبات المسامير عند التثبيت في أنواع أخرى من الحوائط.
- يجب أن يكون الأداء من حيث حجز الفضلات ذا حجم مناسب.
- يسمح بتوصيل الدش بخلاط الماء فقط بعد صمام حبس الماء.

### تعليمات الصيانة

- يجب فحص صمام عدم الرجوع بصفة منتظمة حسب المواصفة DIN EN 1717 وذلك طبقاً للوائح الوطنية أو الإقليمية (مرة واحد سنوياً طبقاً للمواصفة DIN 1988).

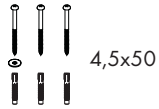
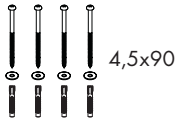
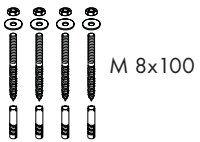
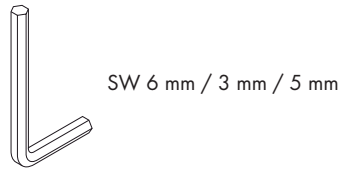
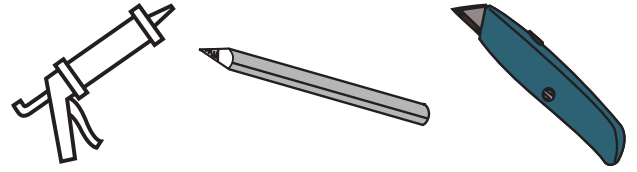
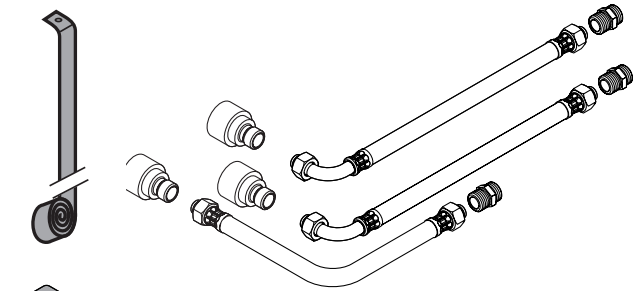
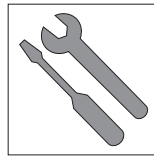
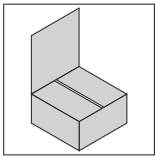

### Rainmaker

26117000 / 28404000 / 28412180

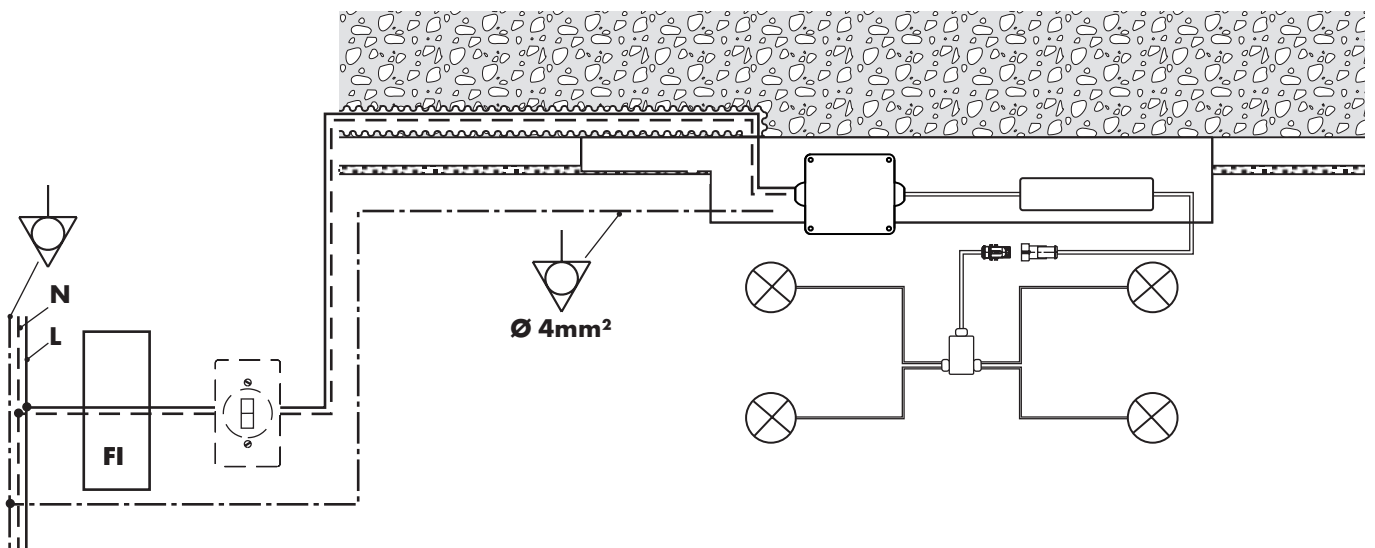

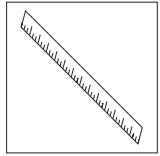

**Rainmaker**  
26117000 / 28404000 / 28412180

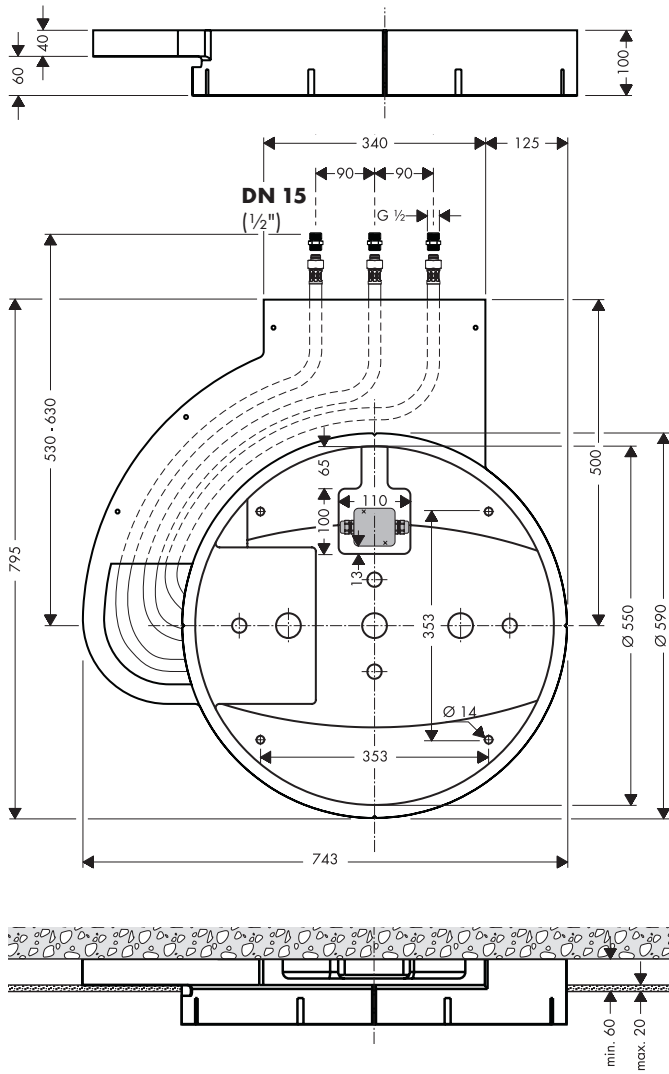

**Rainmaker**  
26115000 / 28403000 / 28412180

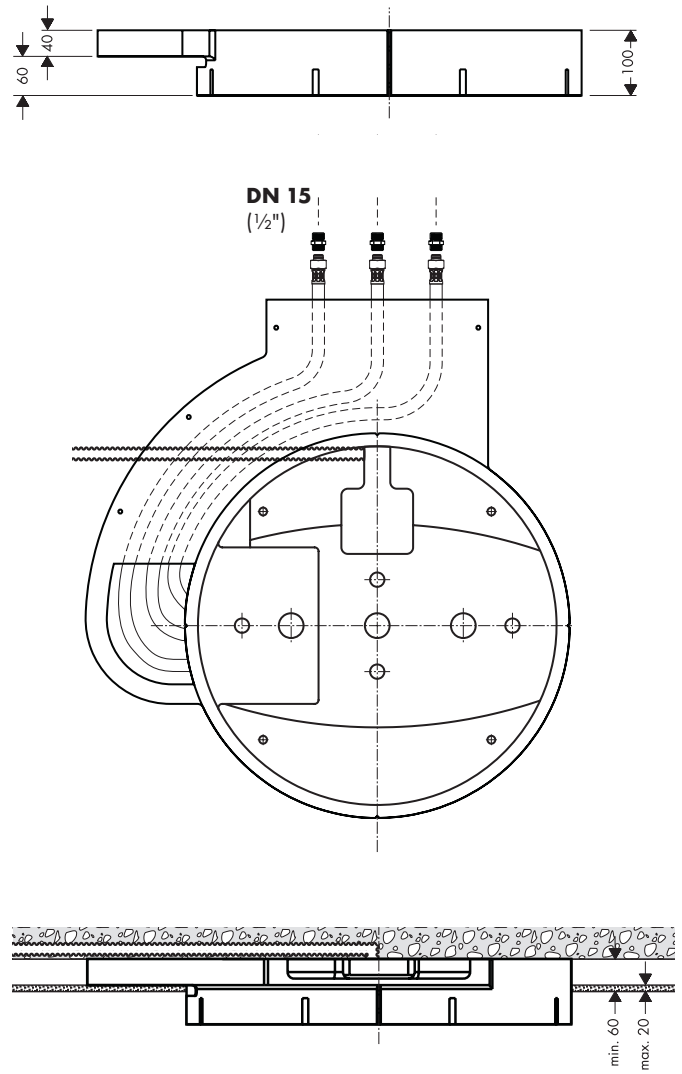

**Rainmaker**  
26115000 / 26117000 / 28403000 / 28404000

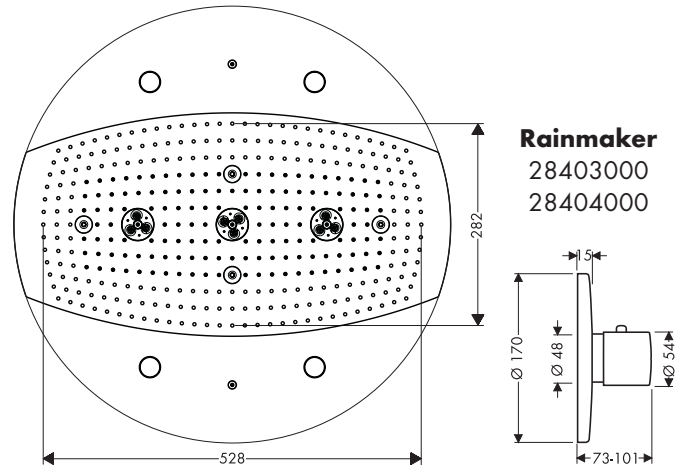
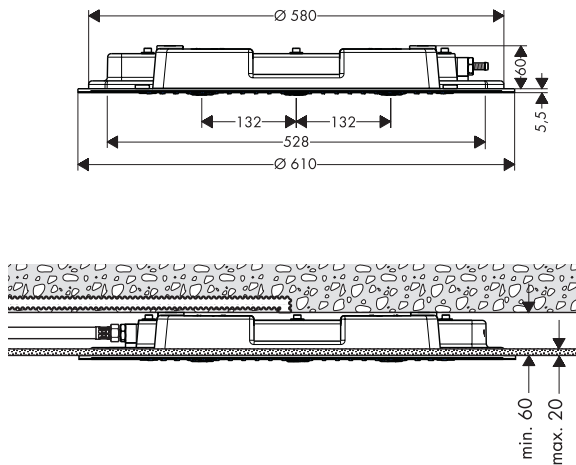

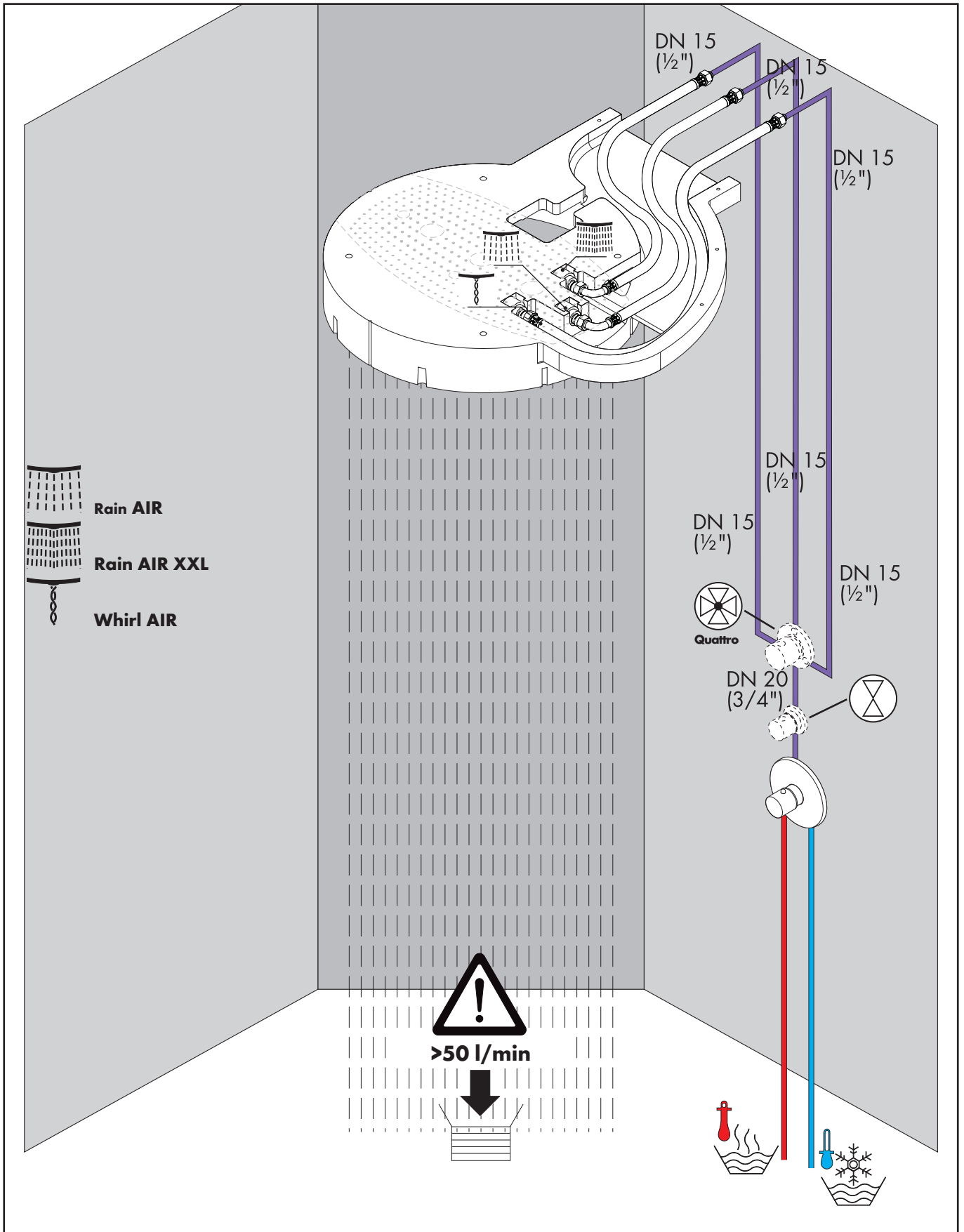

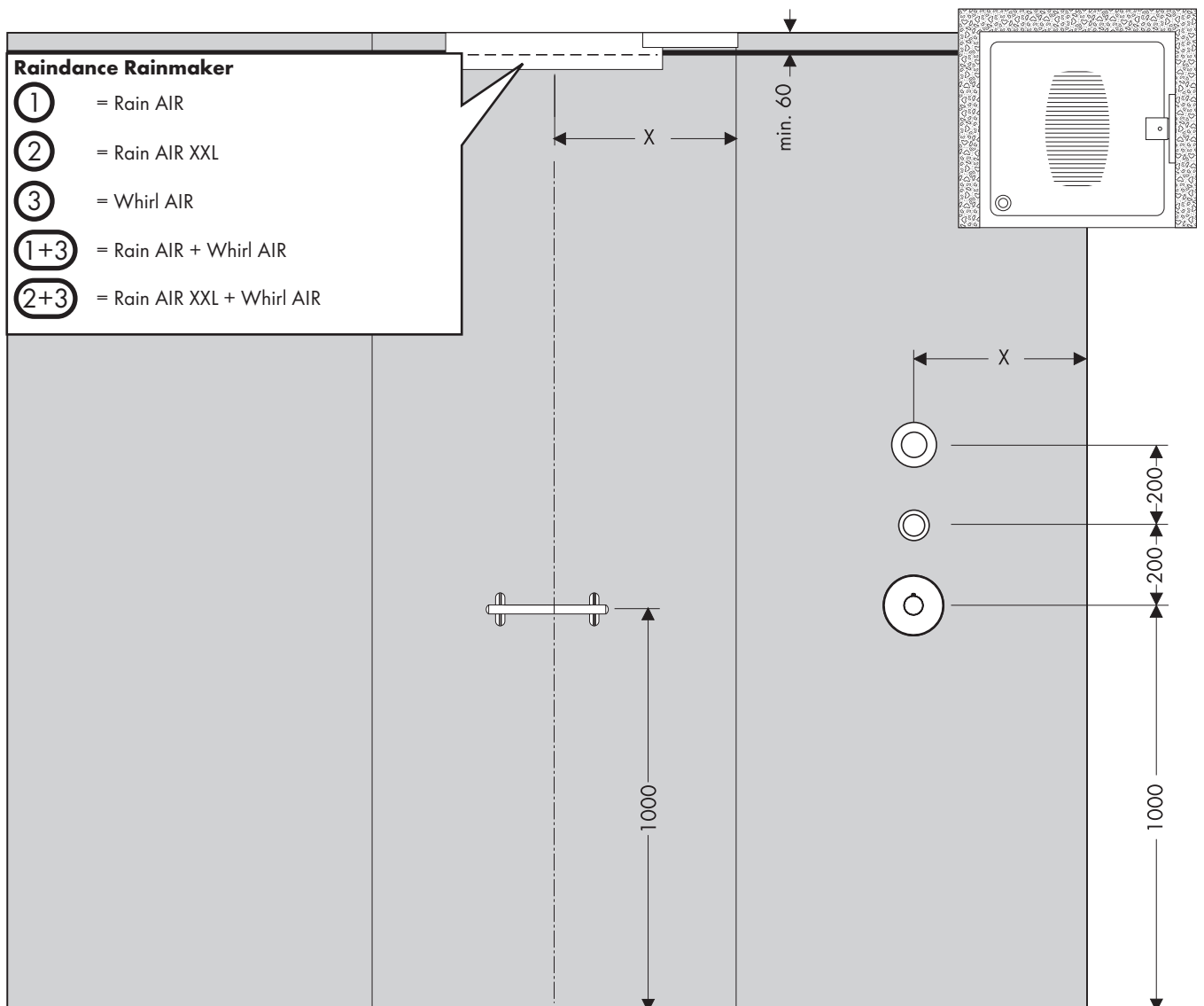
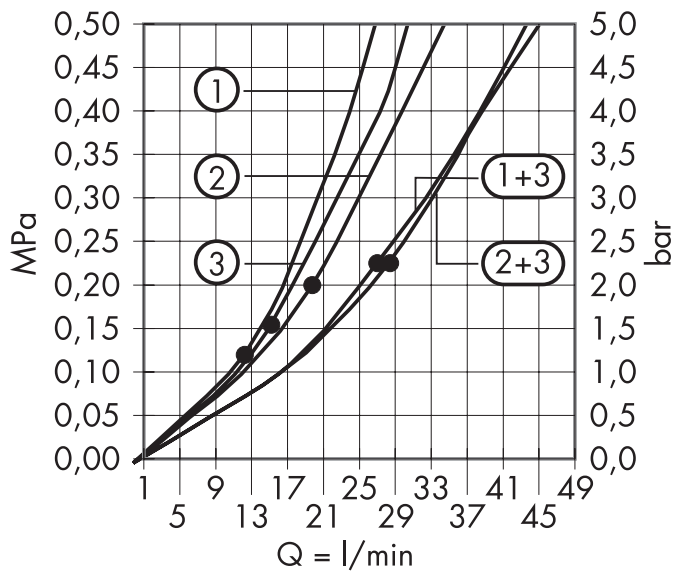

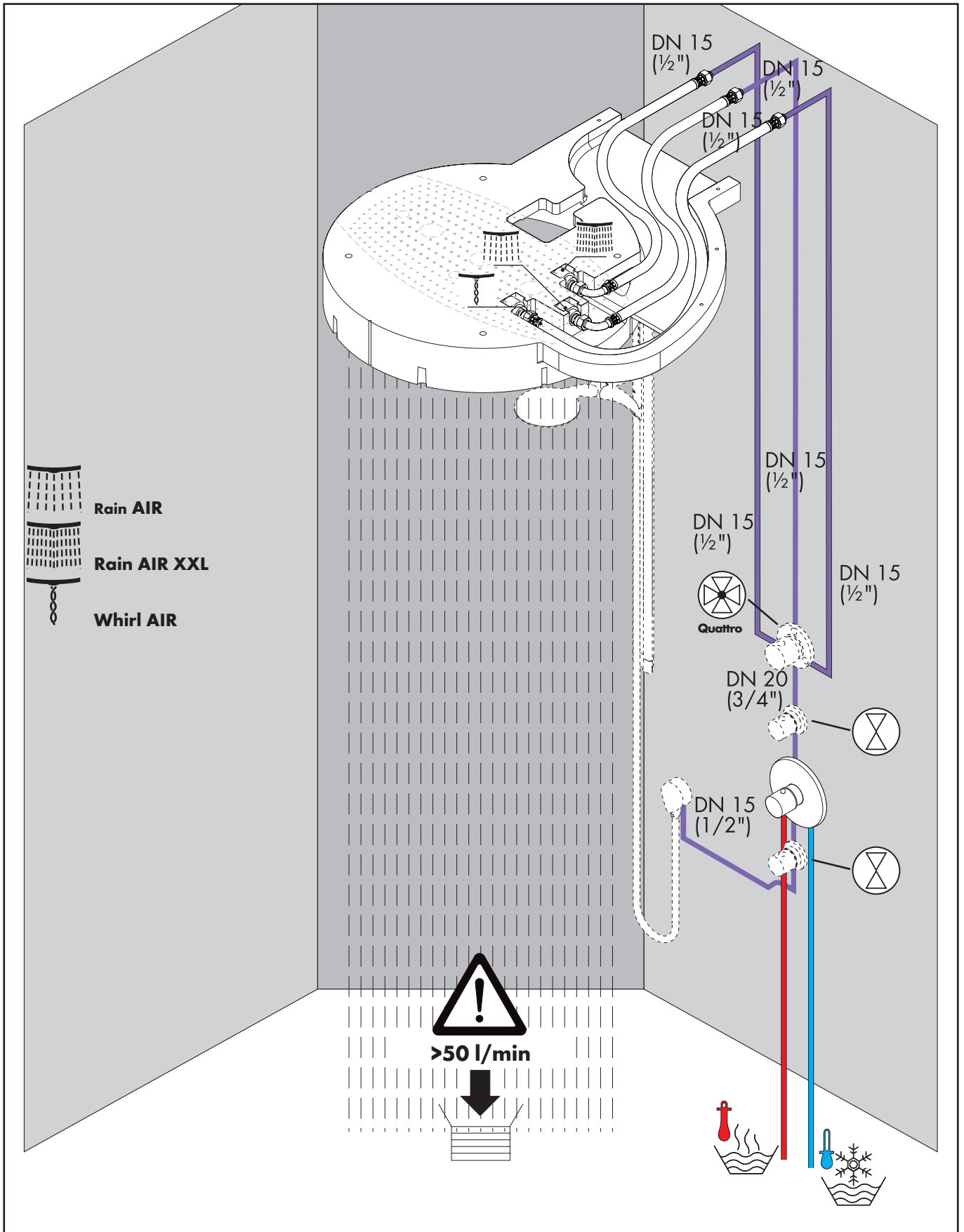



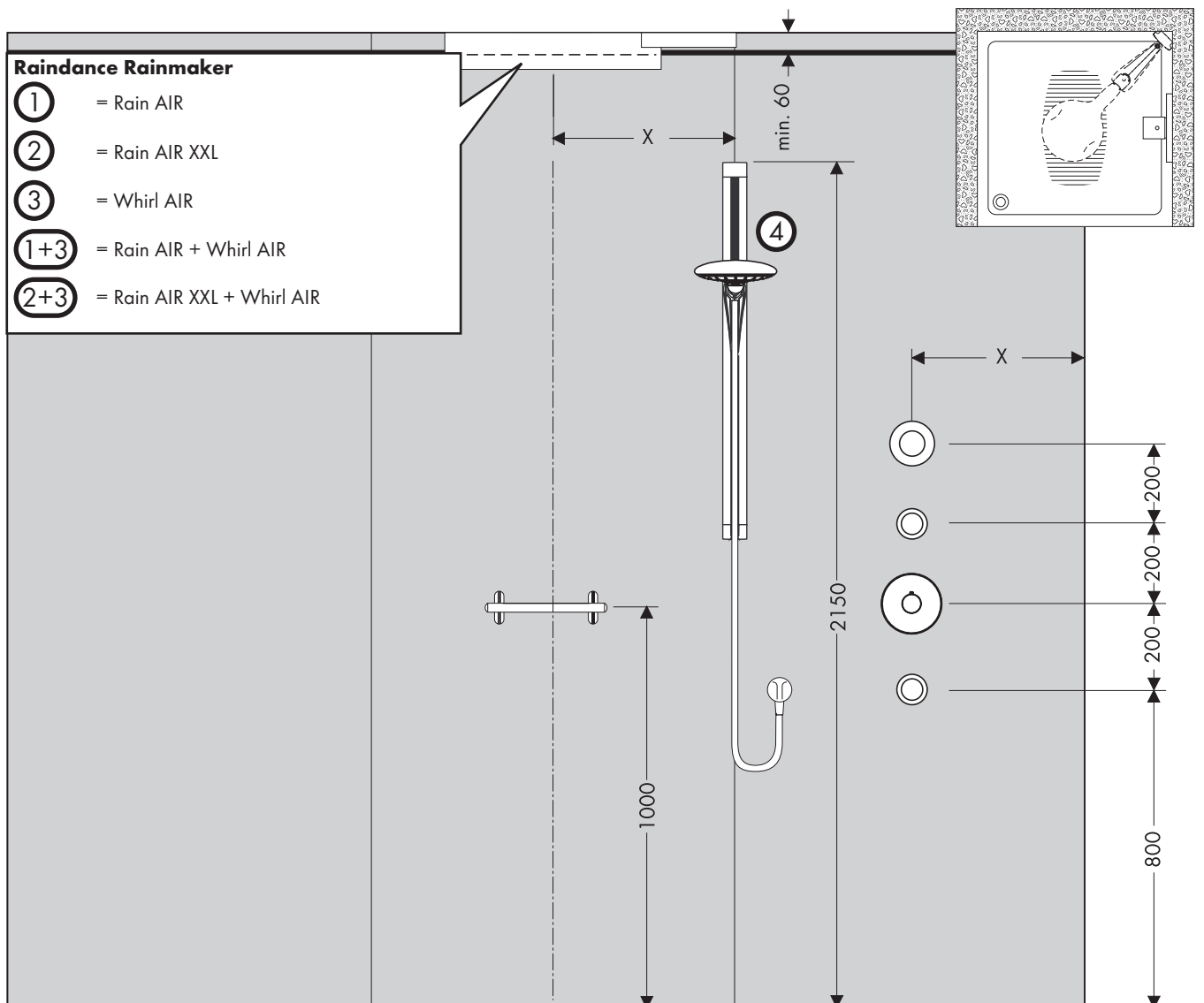
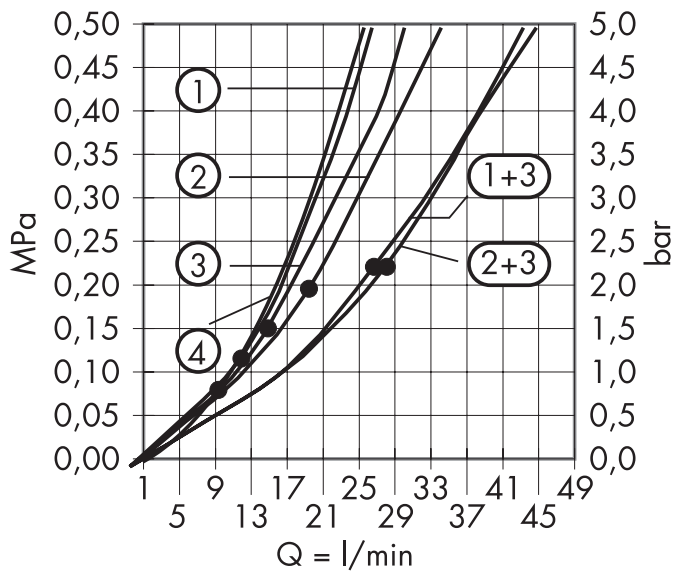

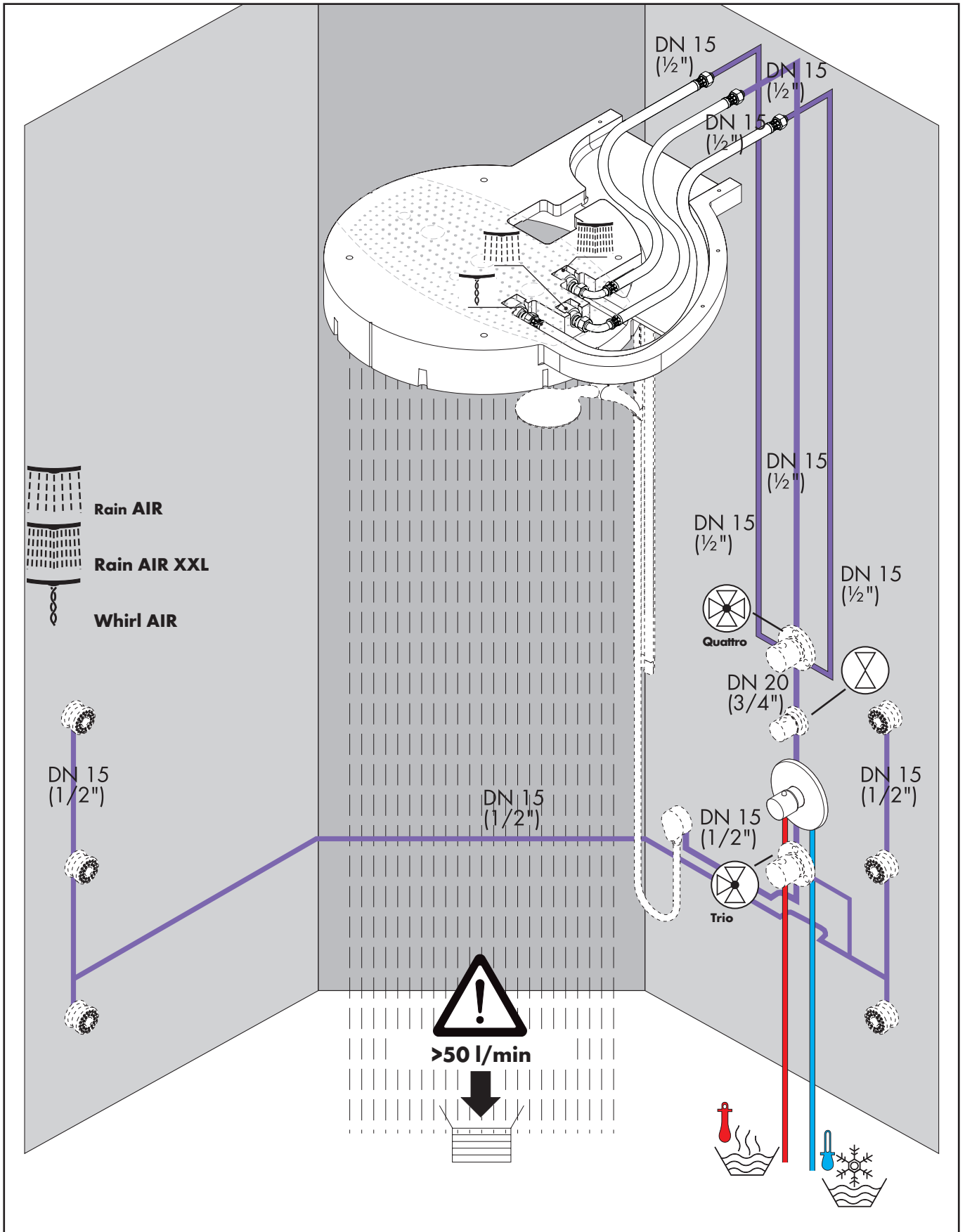

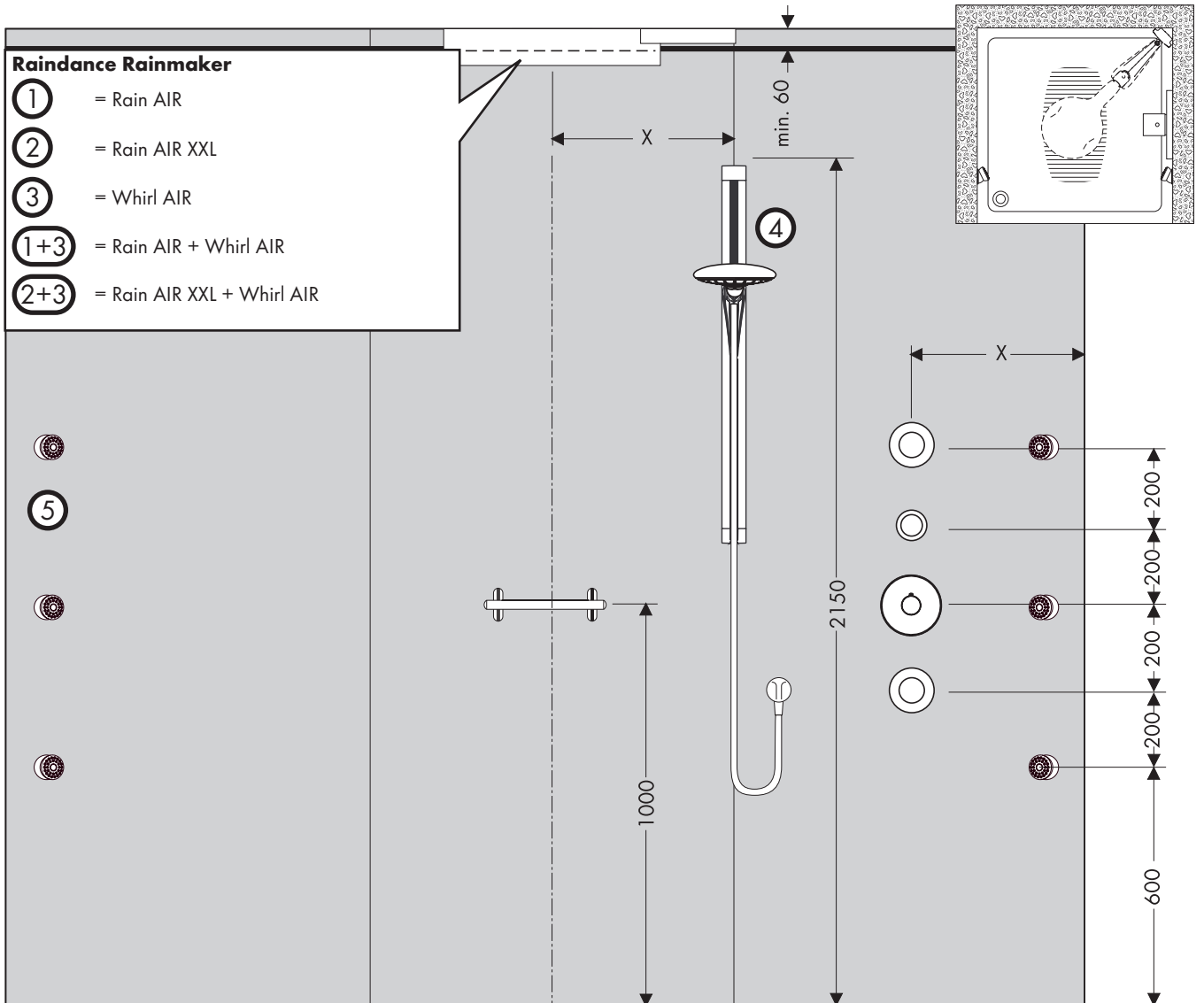
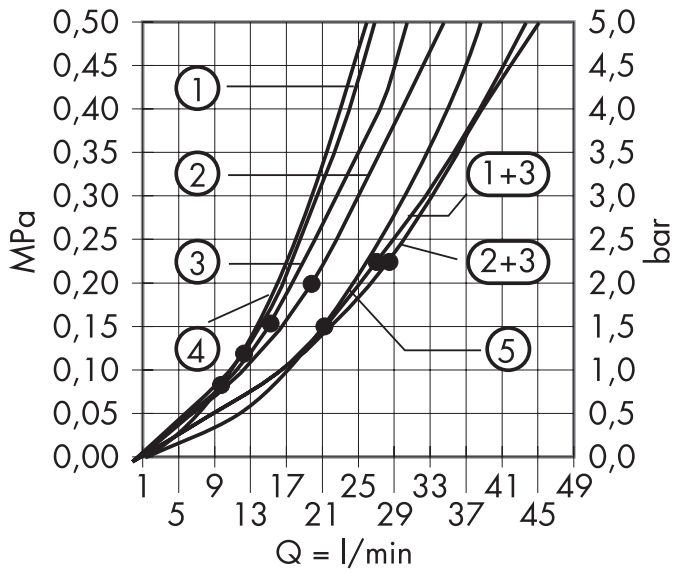

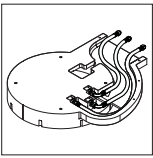

**Rainmaker**  
28412180

<b>Montage</b>	<b>Montagem</b>	<b>Монтаж</b>	<b>Sastavljanje</b>	<b>Paigaldamine</b>	<b>Montimi</b>
<b>Assembly</b>	<b>Montaż</b>	<b>Сzerelés</b>	<b>Montaji</b>	<b>Montāža</b>	<b>الترايب</b>
<b>Montaggio</b>	<b>Montáž</b>	<b>Asennus</b>	<b>Montare</b>	<b>Montaža</b>	
<b>Montaje</b>	<b>Montáž</b>	<b>Montering</b>	<b>Συναρμολόγηση</b>	<b>Montasje</b>	
<b>Montering</b>	<b>安裝</b>	<b>Montavimas</b>	<b>Montaža</b>	<b>Монтаж</b>	

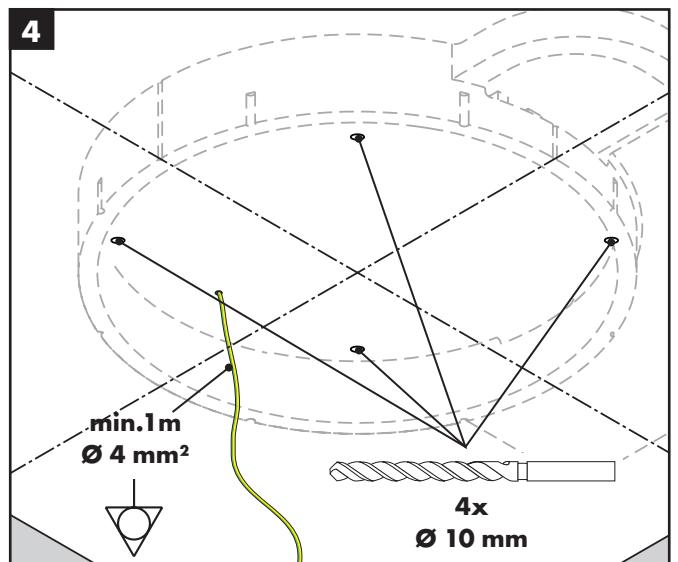
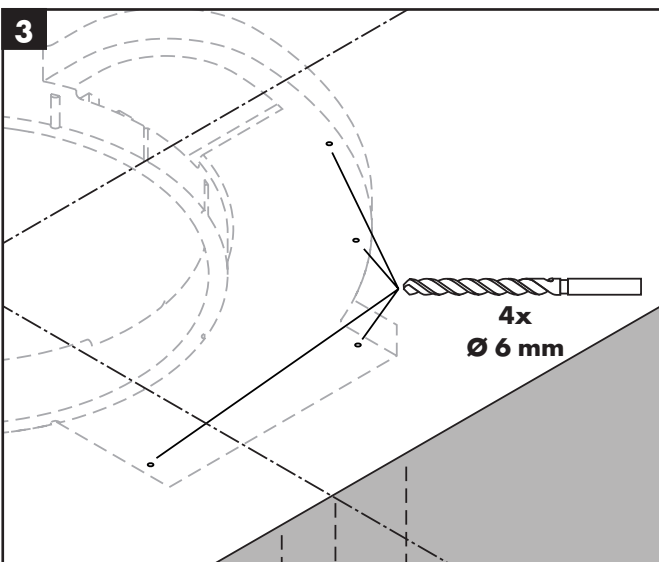
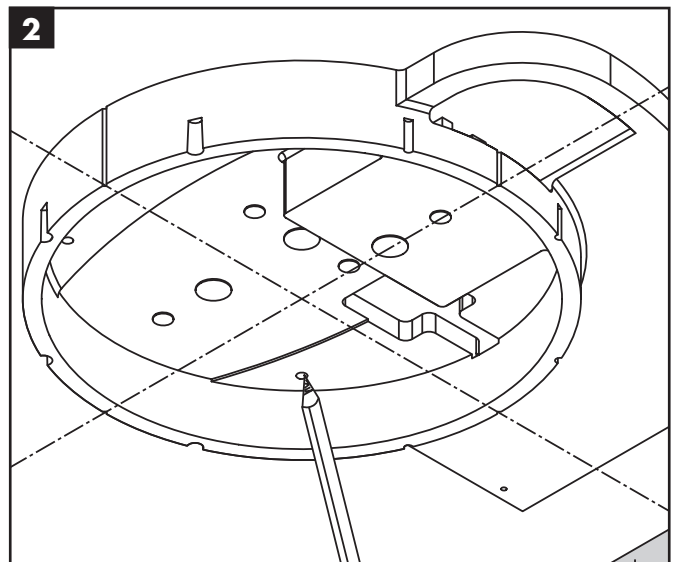
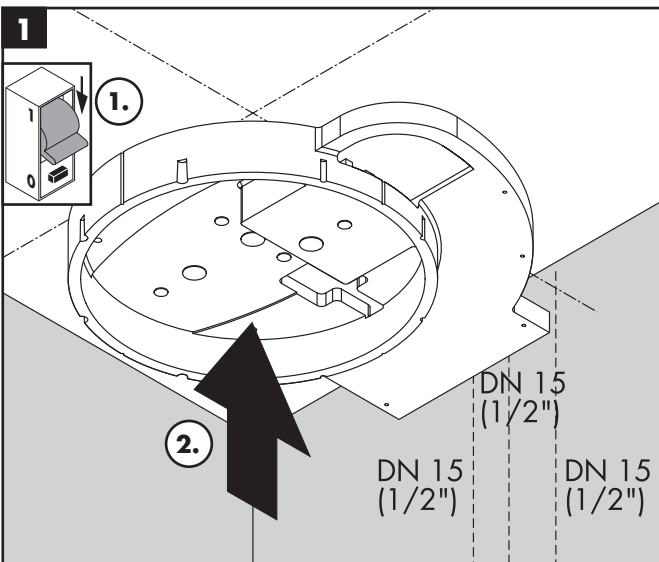
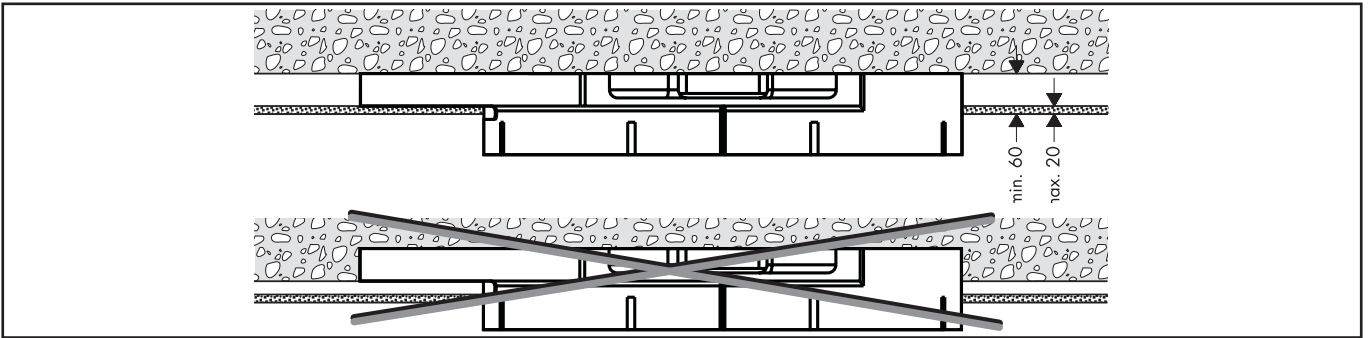

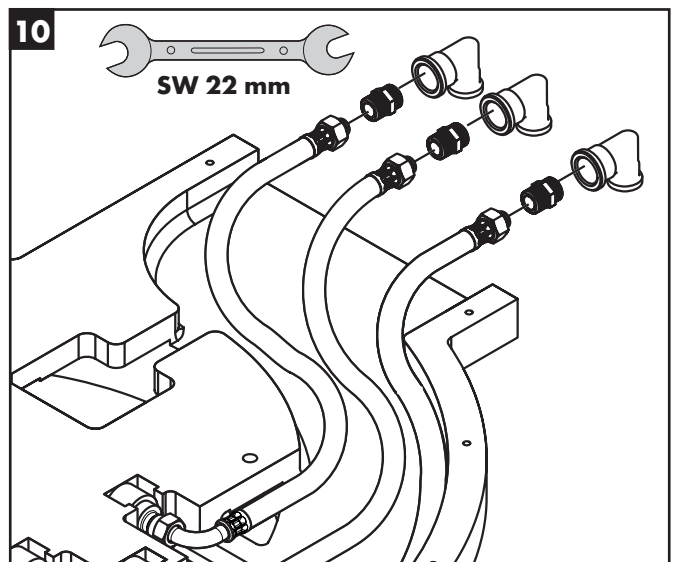
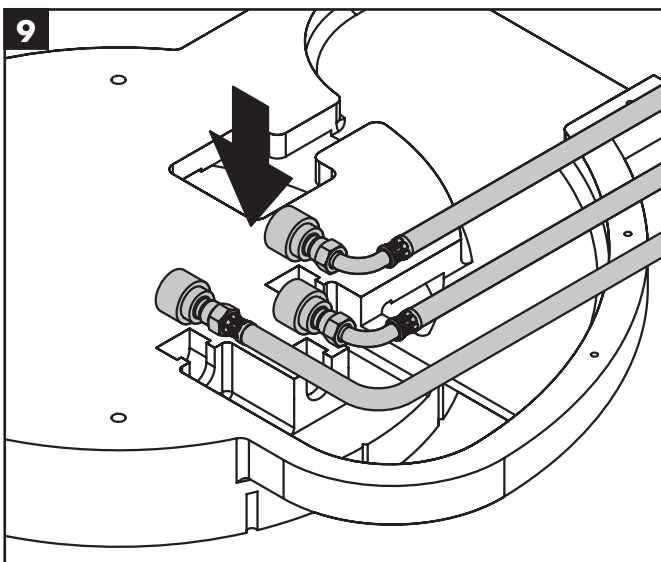
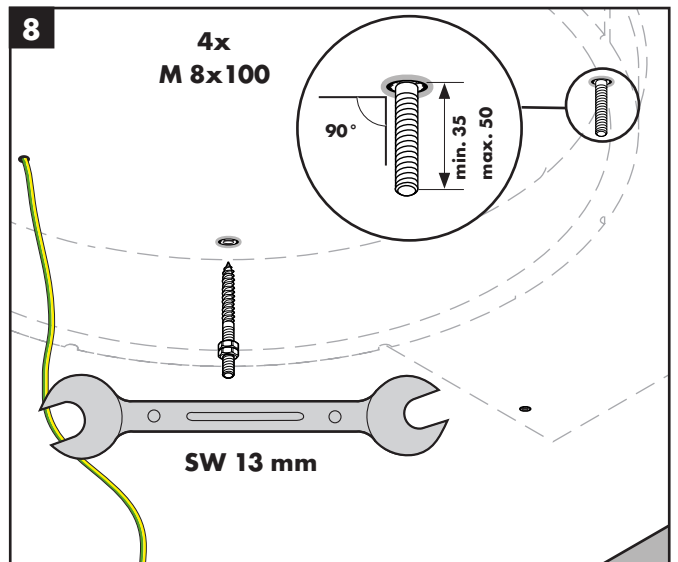
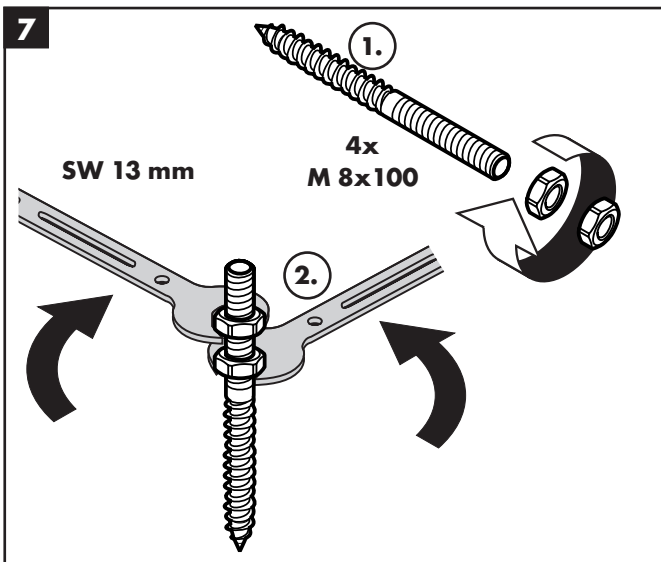
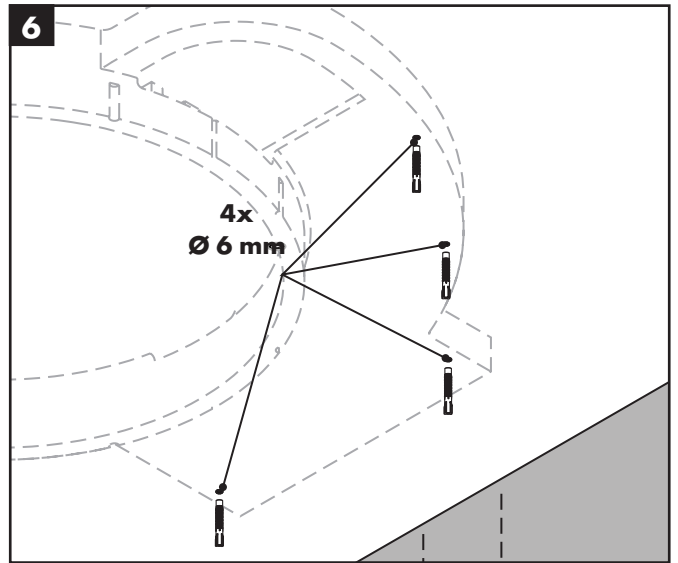
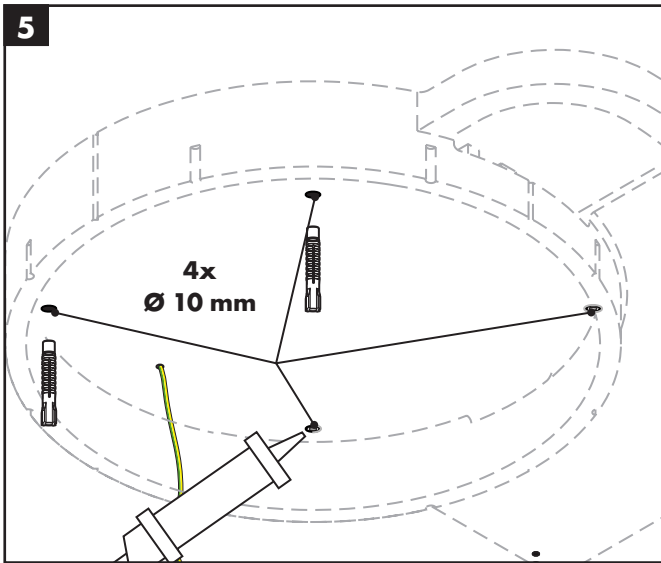
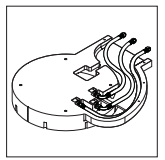

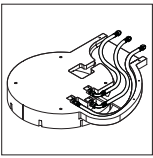

**Rainmaker**  
28412180

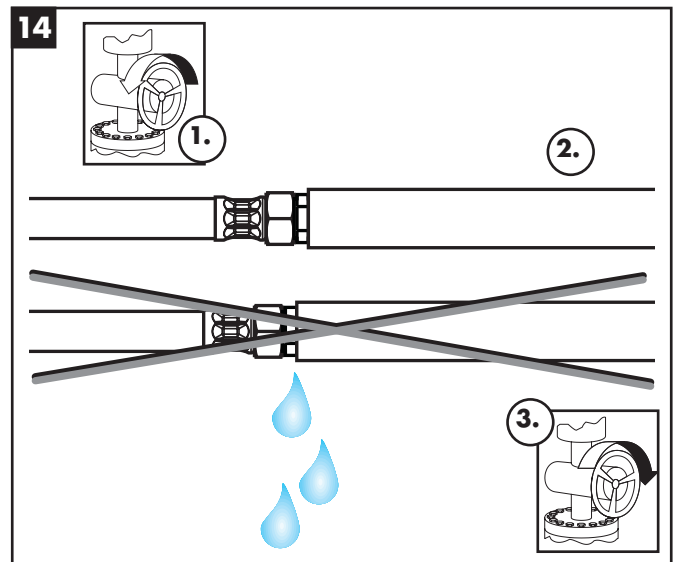
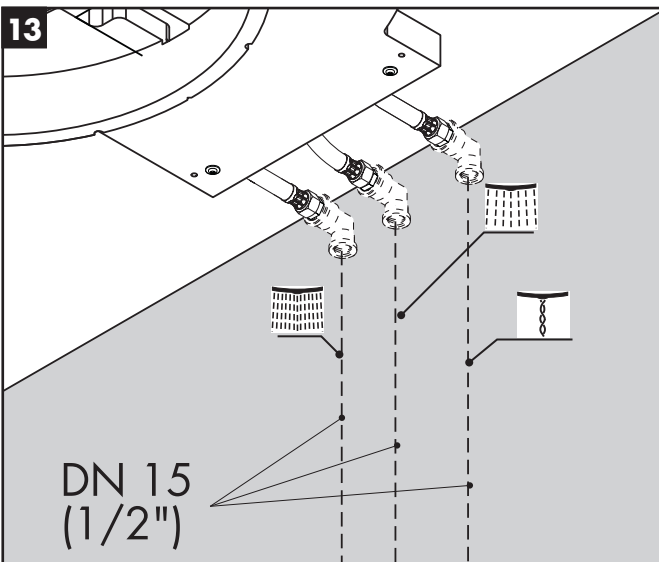
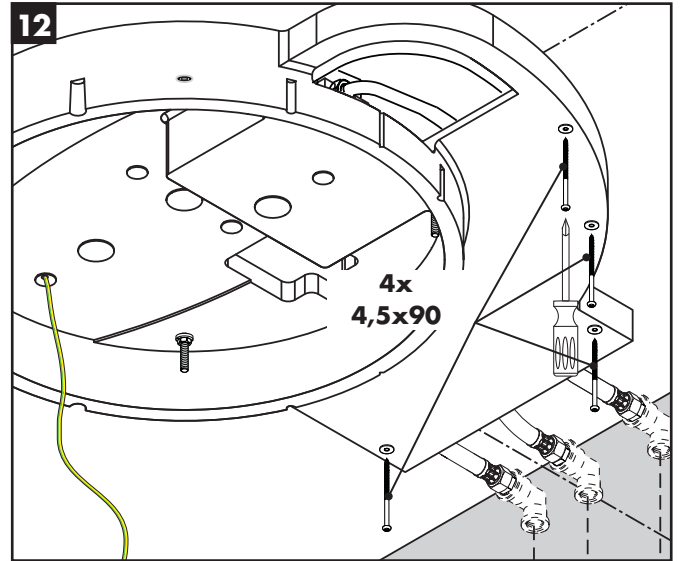
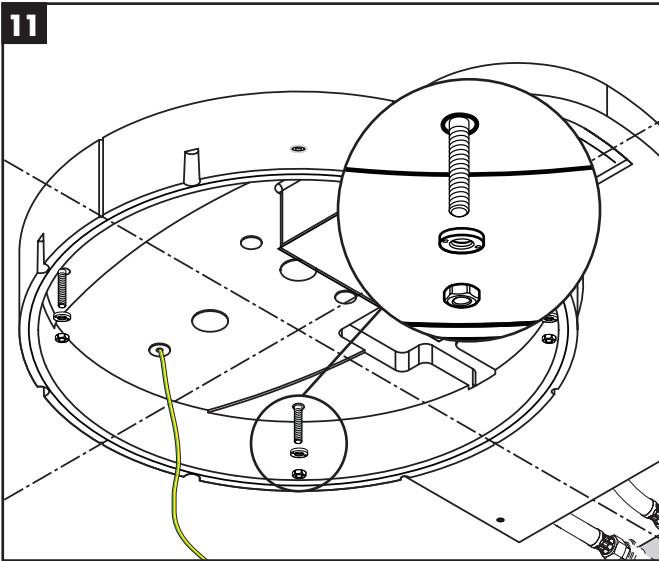

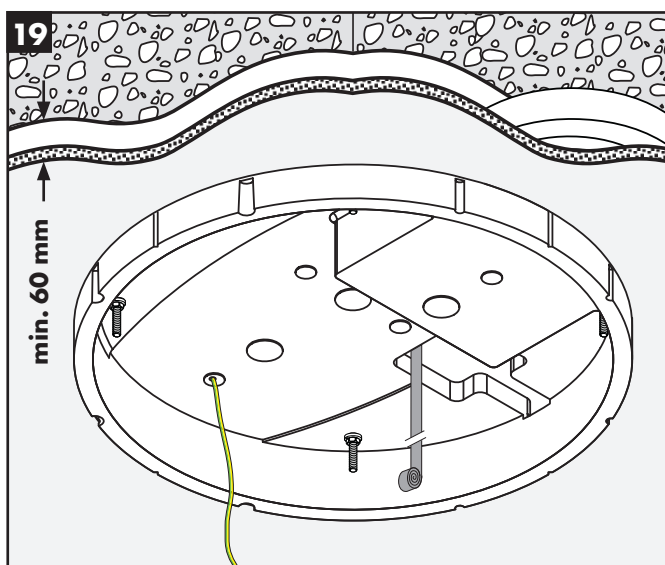
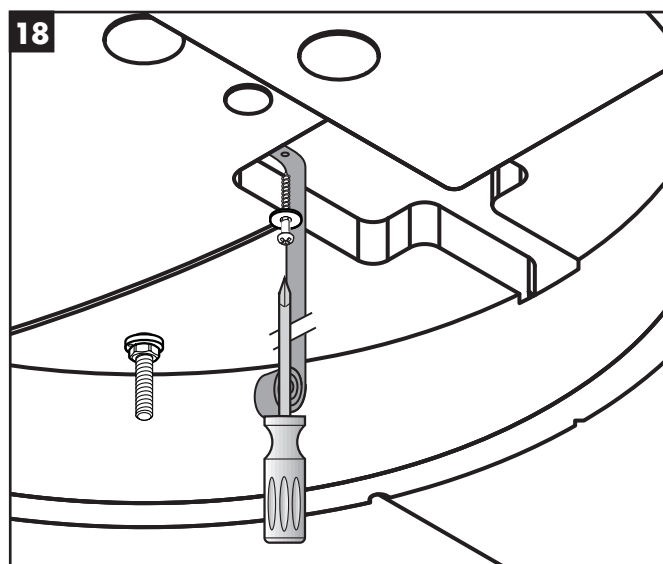
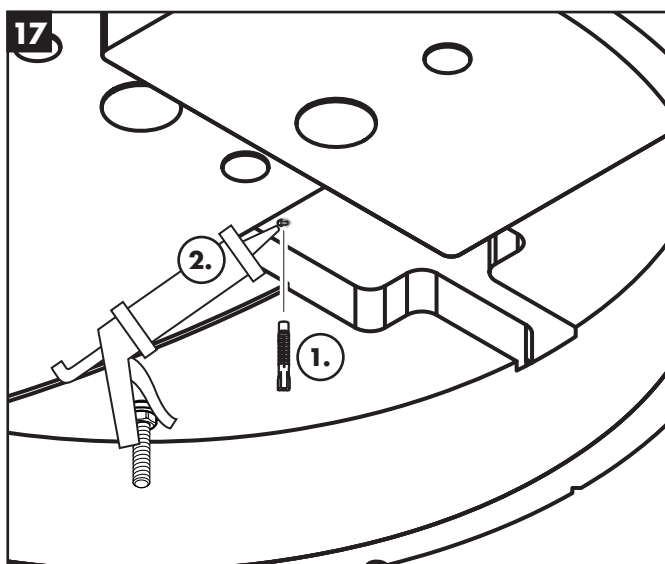
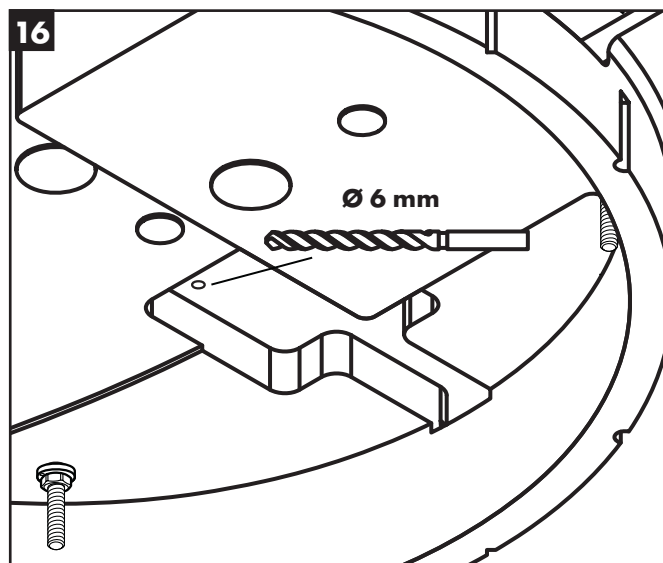
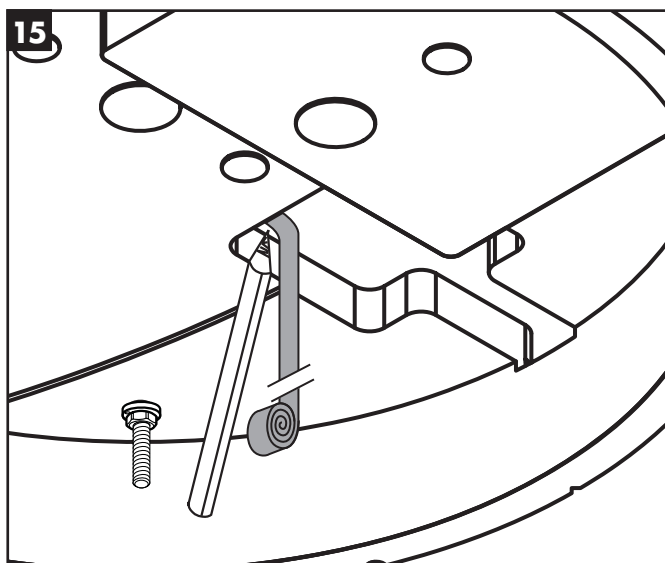
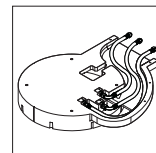

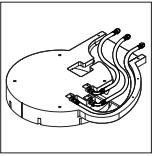

### Rainmaker

28412180 + 28404000 + 26117000

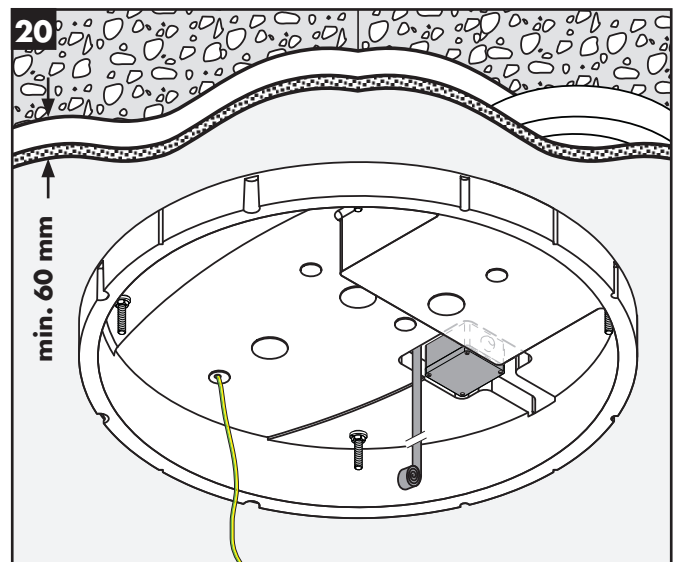
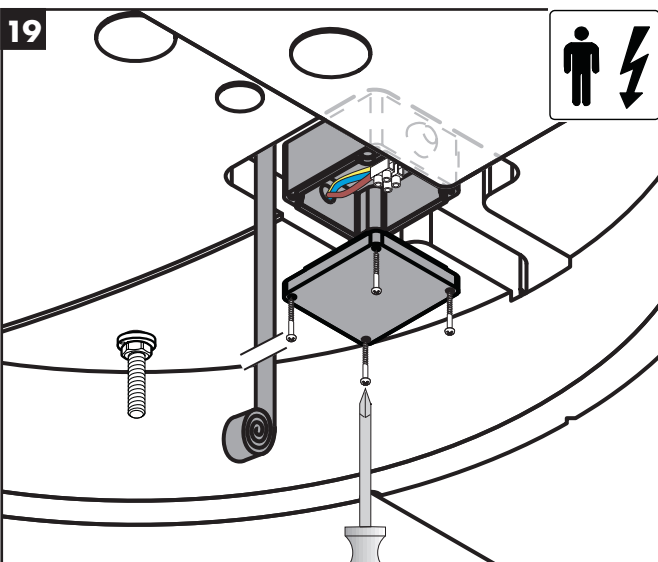
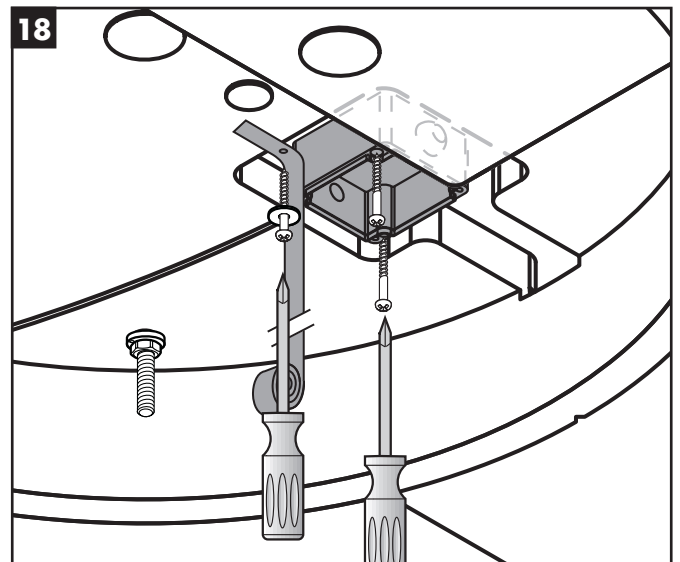
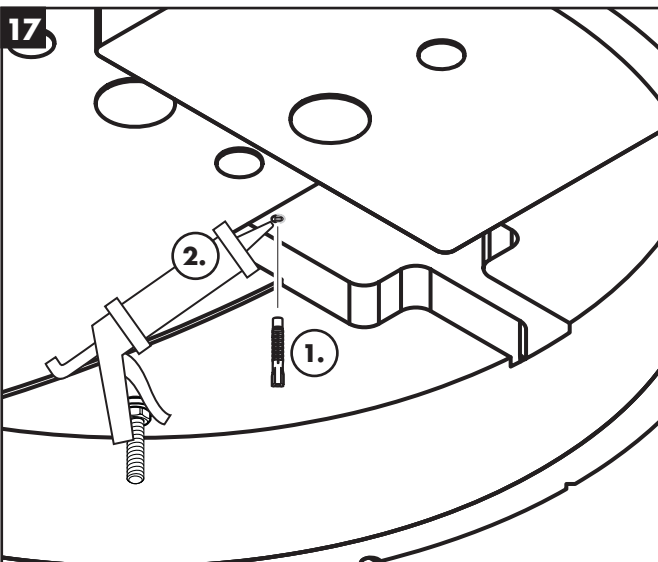
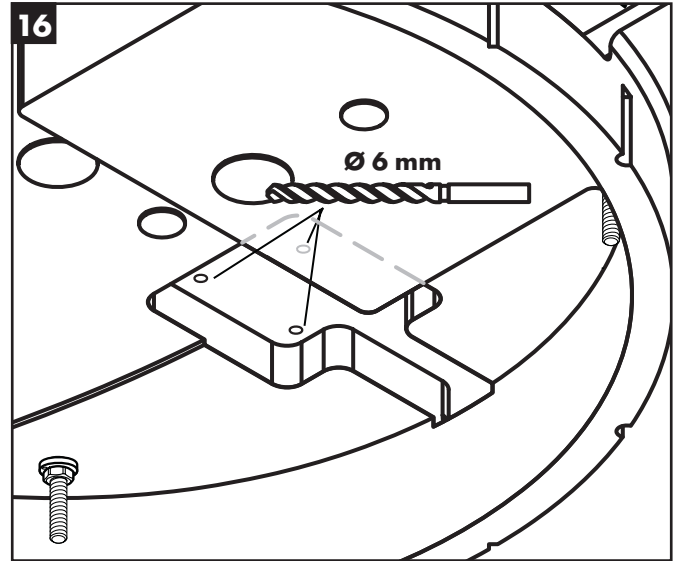
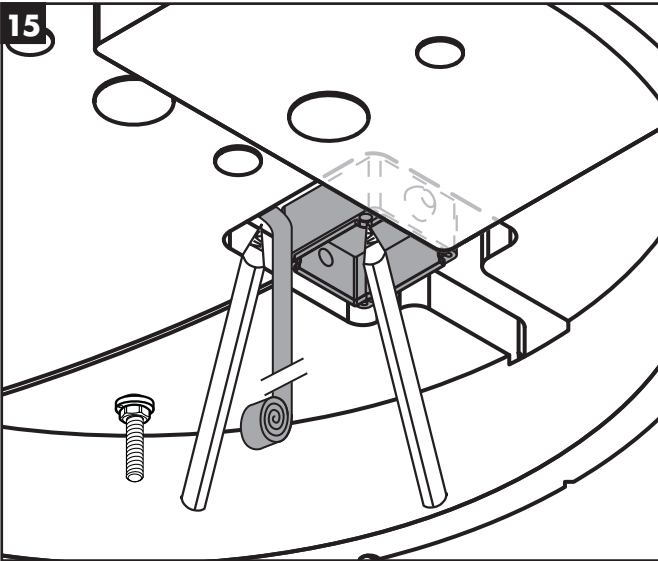



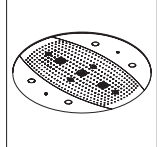

### Rainmaker

26115000 / 26117000 / 28403000 / 28404000

### Highflow 15715000

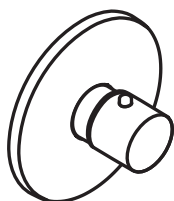

Montageanleitung	Monteringsvejledning	Инструкция по монтажу	Montaj kilavuzu	Uputstvo za montažu
Instructions de montage	Manual de Instalación	Szerelési útmutató	Instruċjuni de montare	Lysmiddel
Assembly instructions	Instrukcja montażu	Asennusohje	Οδηγία συναρμολόγησης	Ръководство за монтаж
Istruzioni per Installazione	Montážní návod	Monteringsanvisning	Navodila za montažo	Udhëzime rreth montimit
Instrucciones de montaje	Montážny návod	Montavimo instrukcijos	Paigaldusjuhend	تعليمات التجميع
Handleiding	组装说明	Uputstva za instalaciju	Montāžas instrukcija	

### 90530001

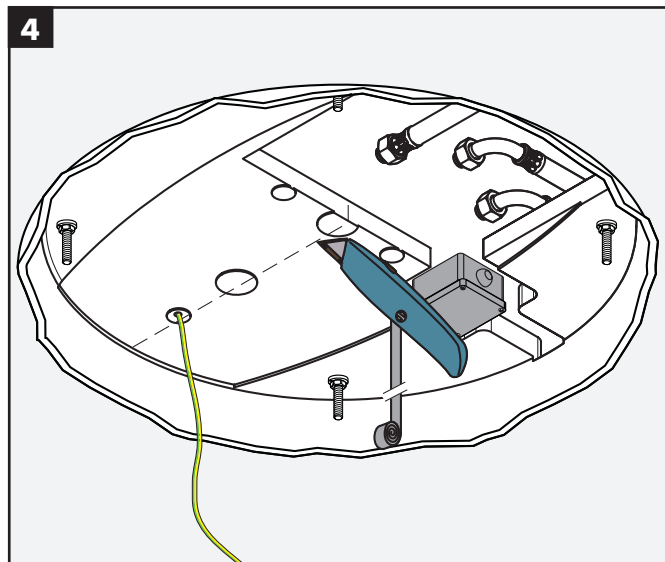
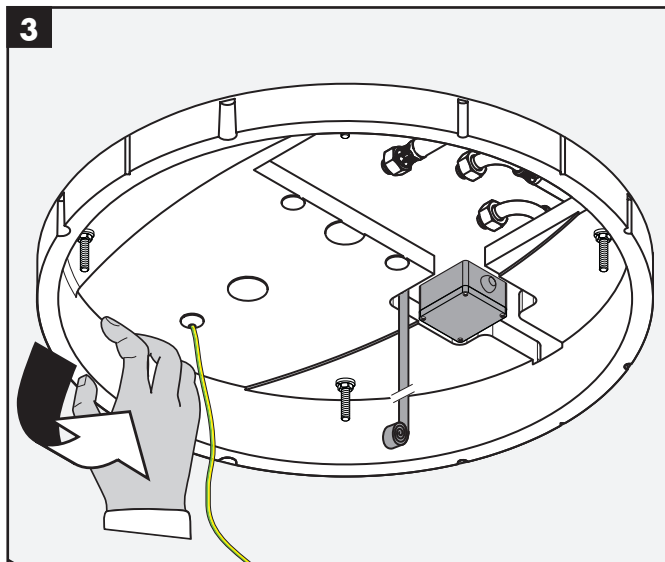
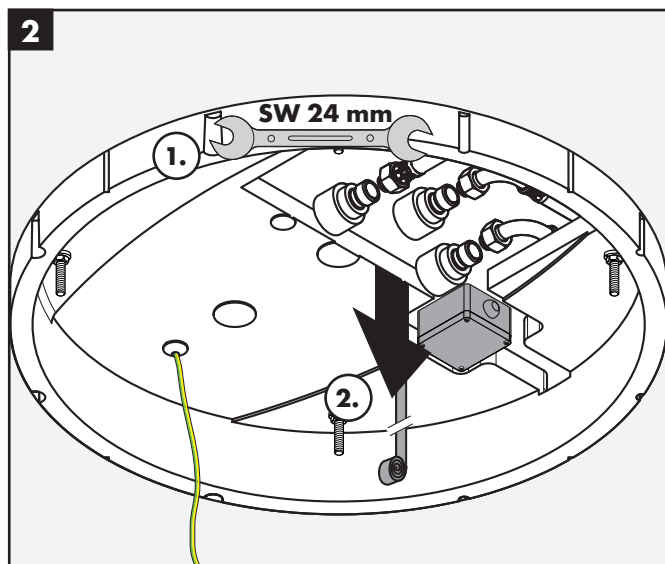
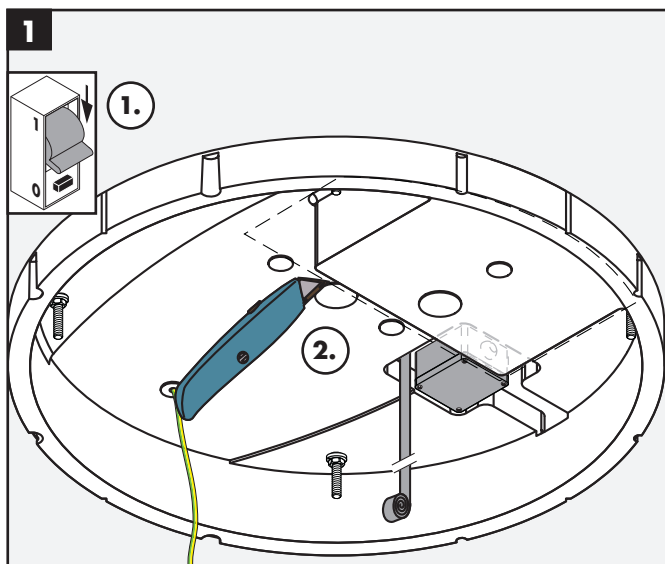

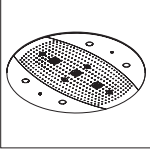

# Rainmaker

26115000 / 26117000 / 28403000 / 28404000

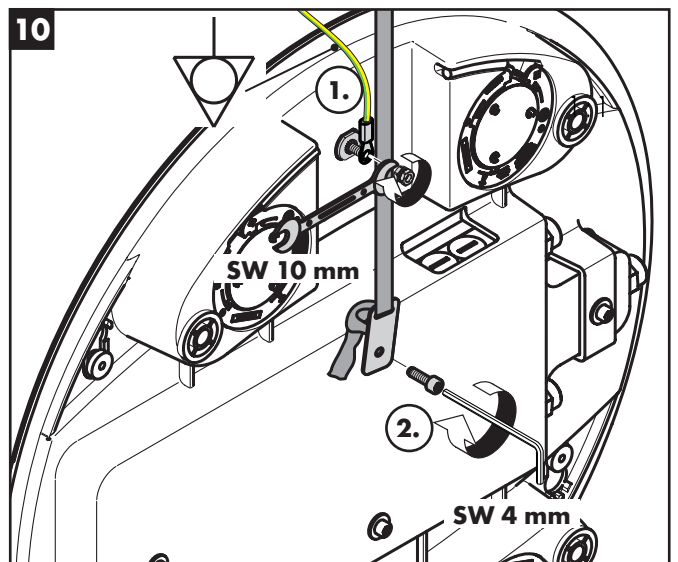
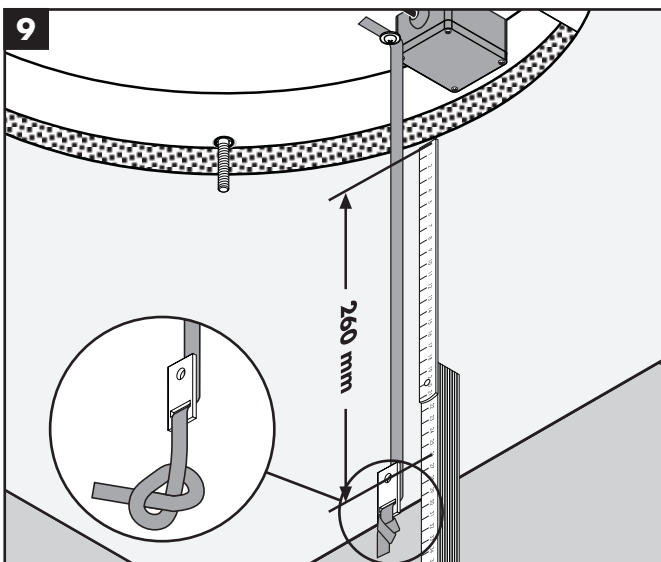
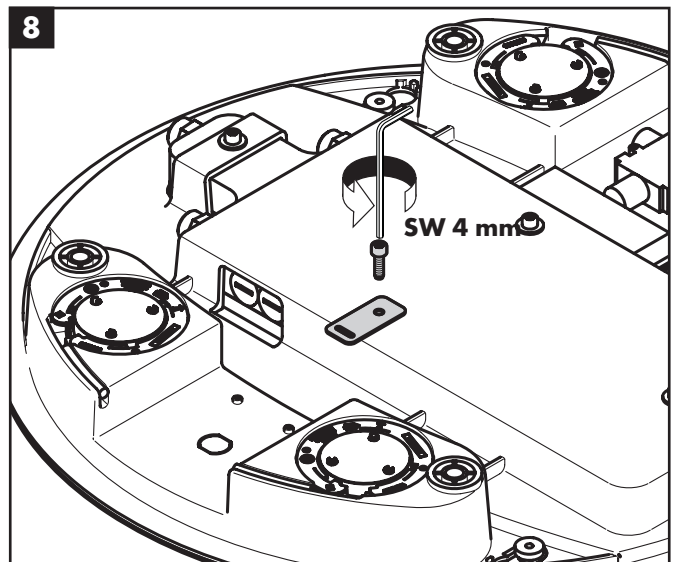
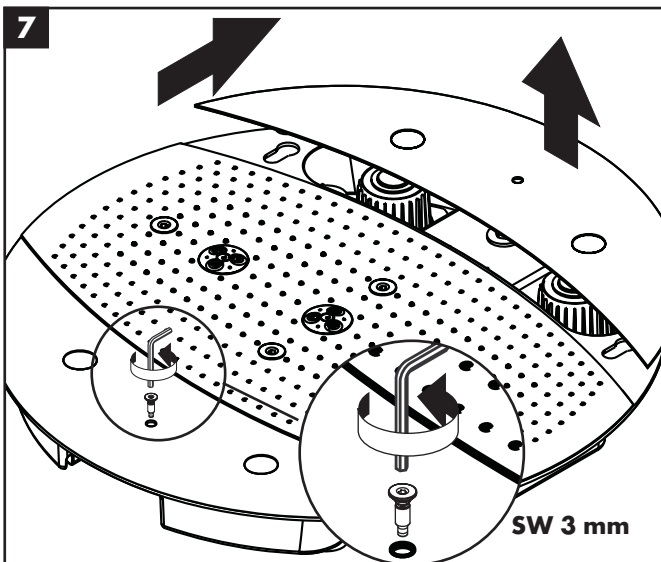
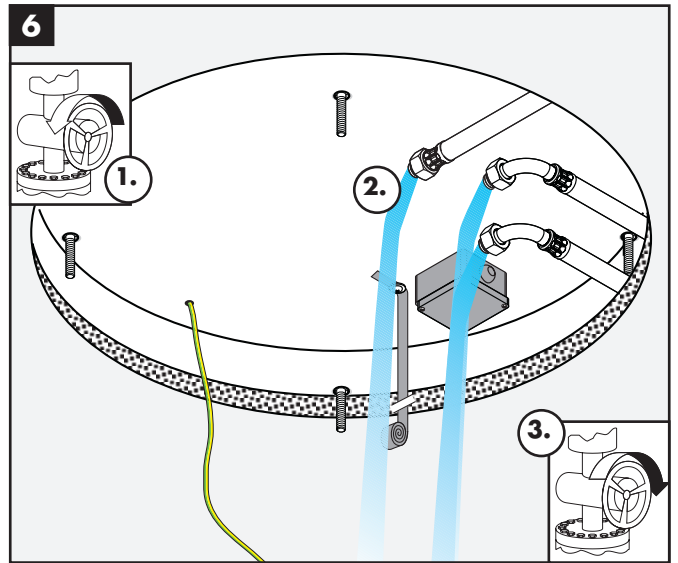
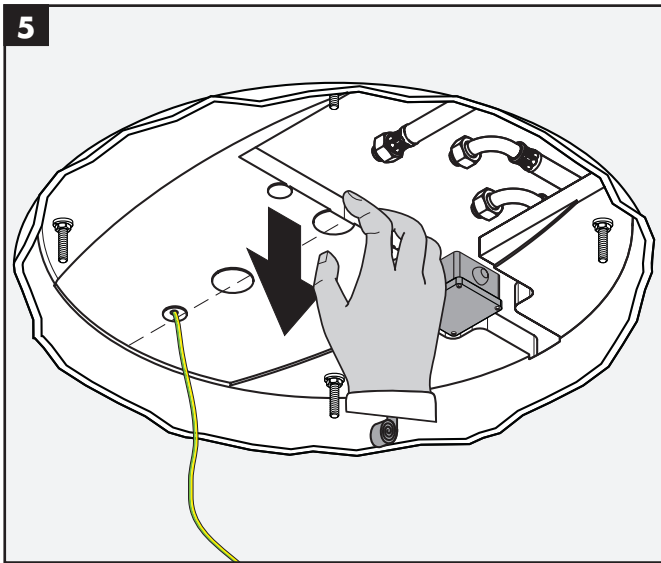

# Rainmaker

26115000 / 26117000 / 28403000 / 28404000

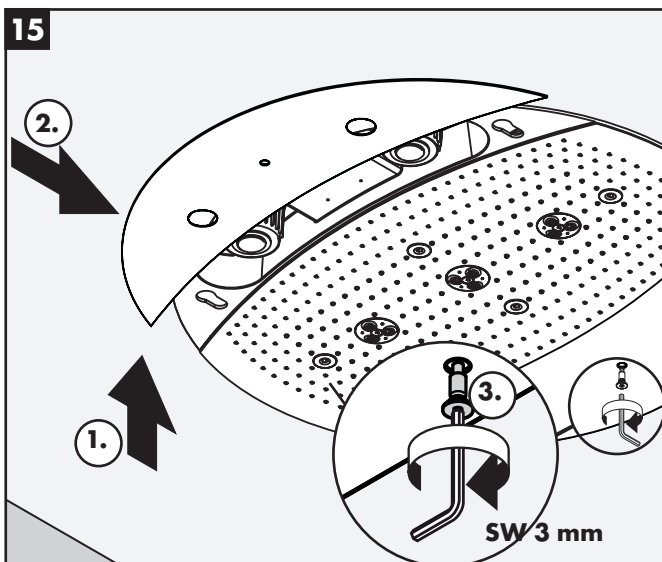
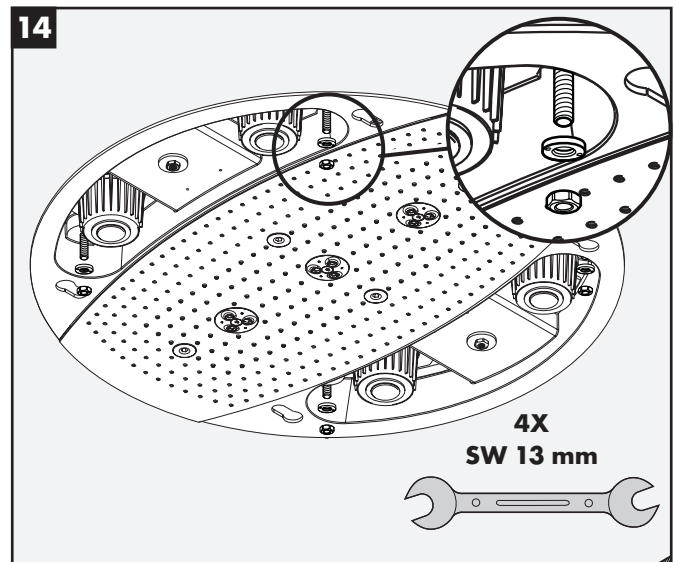
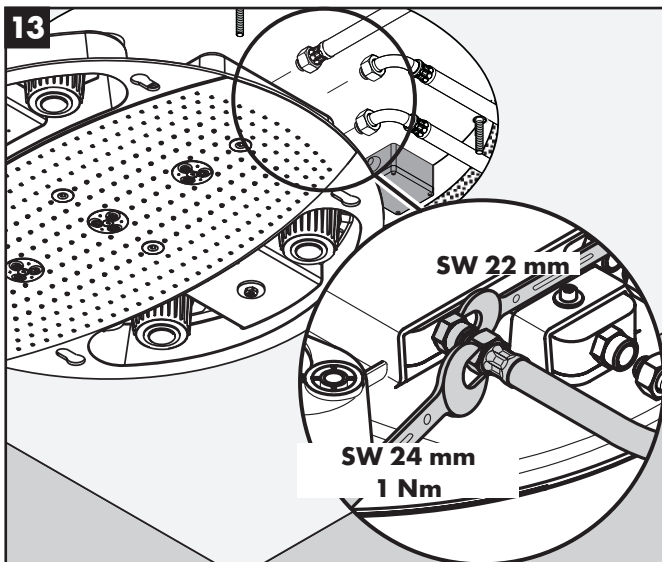
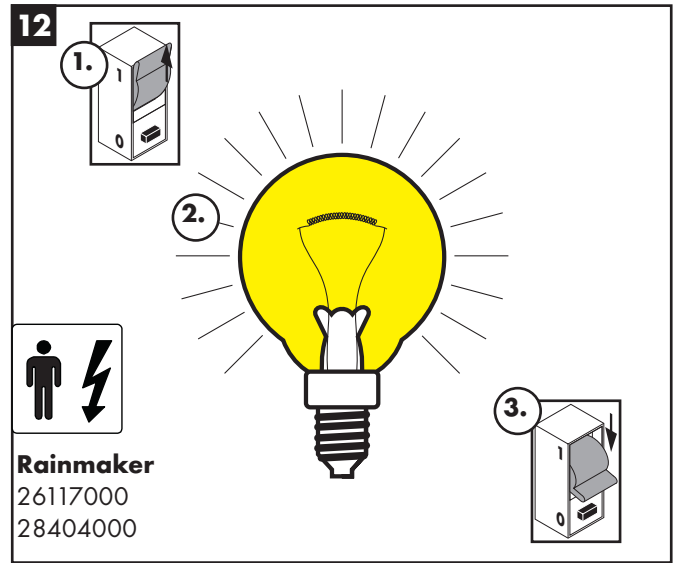
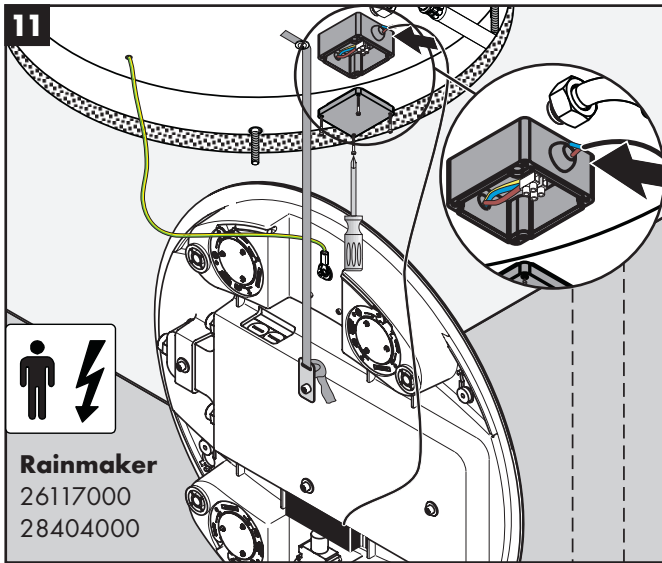
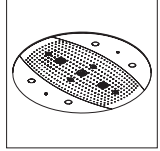

**Bedienung**  
**Instructions de service**  
**Operation**  
**Procedura**

**Manejo**  
**Bediening**  
**Brugsanvisning**  
**Funcionamento**  
**Obsługa**

**Ovládání**  
**Obsluha**  
**操作**  
**Эксплуатация**  
**Használat**

**Käyttö**  
**Hantering**  
**Eksplaatatsioon**  
**Upotreba**  
**Kullanımı**

**Utilizare**  
**Χειρισμός**  
**Upravljanje**  
**Kasutamine**  
**Lietošana**

**Rukovanje**  
**Βετινινγ**  
**Обслужване**  
**Përdorimi**  
**التشغيل**

**Rainmaker**

26115000 / 26117000 /  
 28403000 / 28404000

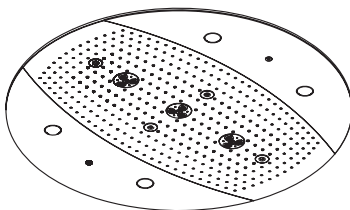

**Rain AIR**

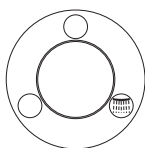

**Whirl AIR + Rain AIR XXL**

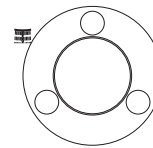

**Rain AIR XXL**

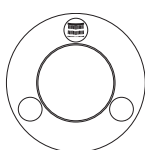

**Whirl AIR + Rain AIR**

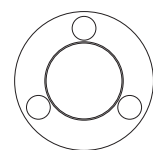

**Whirl AIR**

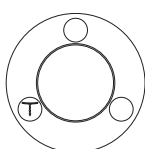

**Rain AIR XXL + Rain AIR**

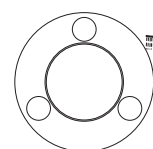

**Ersatzteile**  
**Pièces de rechange**  
**Spare parts**  
**Ricambi**  
**Piezas de recambio**  
**Reserveonderdelen**

**Reservedele**  
**Peças sobressalentes**  
**Części zamienne**  
**Náhradní díly**  
**Náhradné diely**  
**备件**

**Запасные части**  
**Alkatrészek**  
**Varaosat**  
**Atsarginės dalys**  
**Atsarginės dalys**  
**Rezervni dijelovi**

**Yedek parçalar**  
**Piese de schimb**  
**Ανταλλακτικά**  
**Nadomestni deli**  
**Varuosad**  
**Rezerves daļas**

**Rezervni delovi**  
**Reservedeler**  
**Резервни части**  
**Pjesët e këmbimit**  
**قطعة غيار**

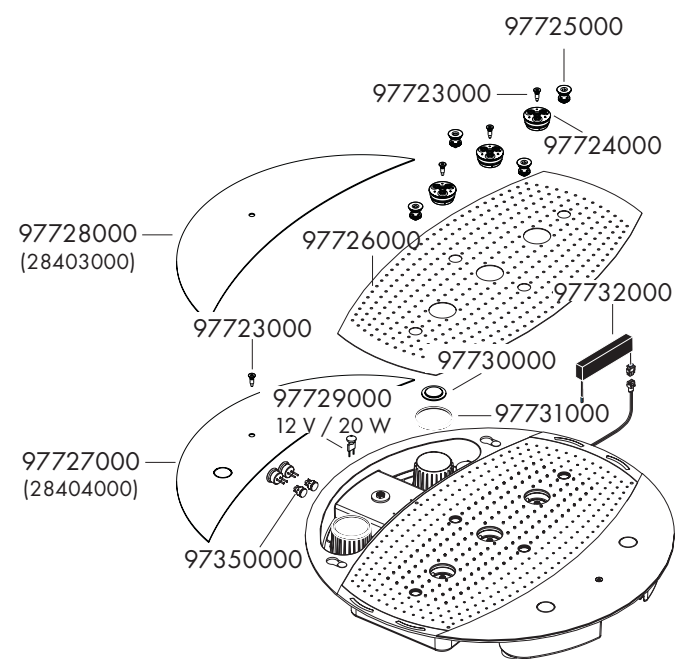
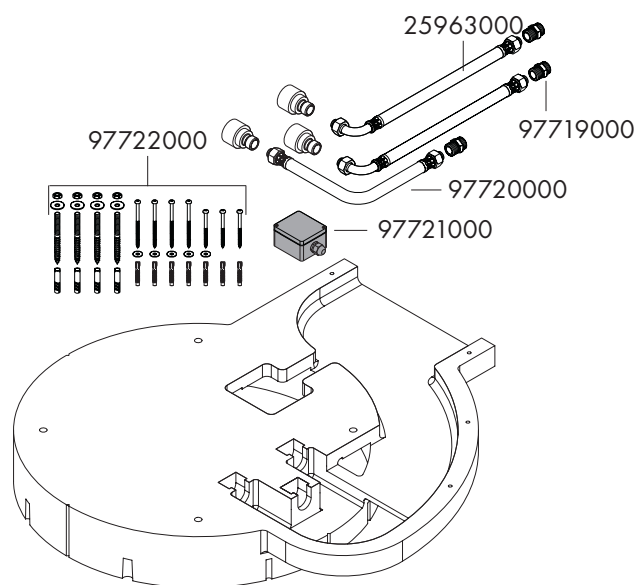

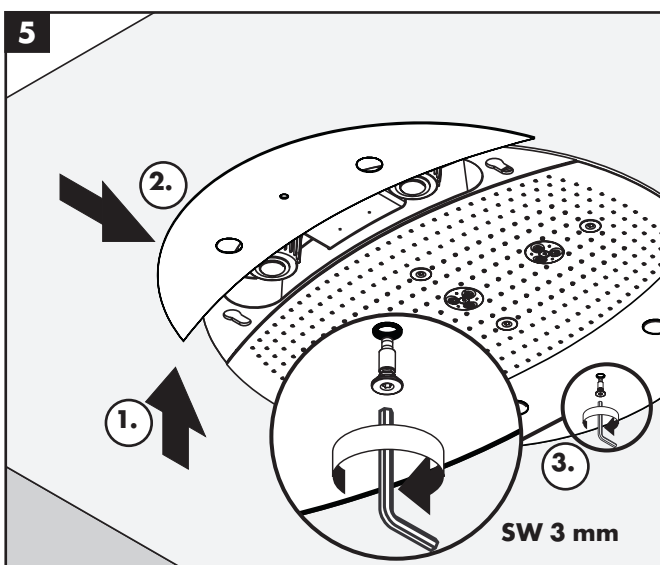
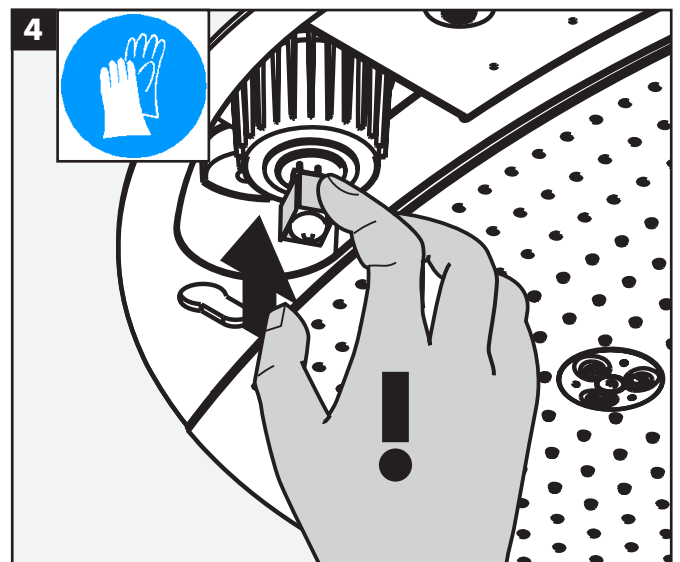
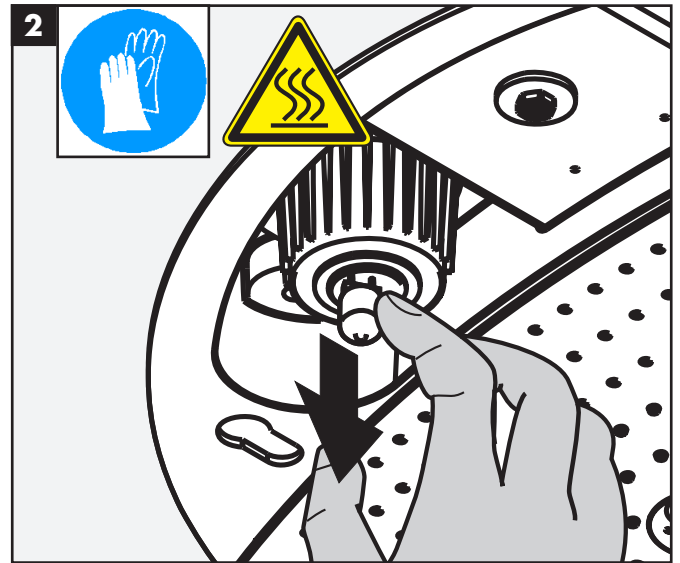
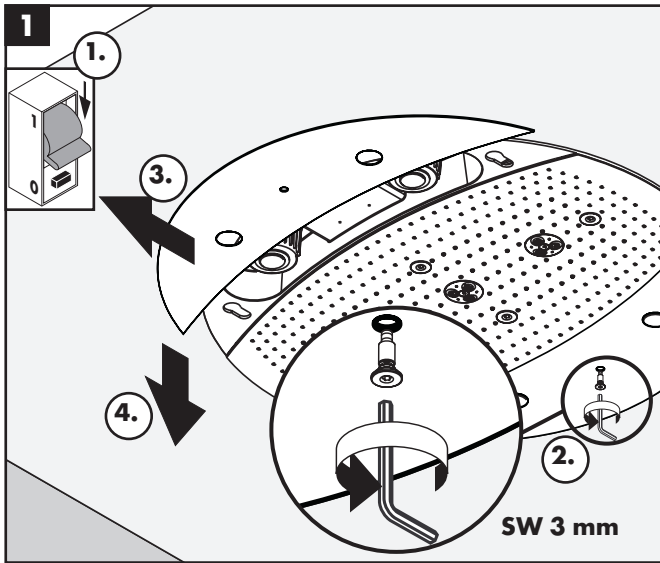

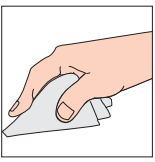

Reinigung  
Nettoyage  
Cleaning  
Pulitura  
Limpiar

Reinigen  
Rengøring  
Limpeza  
Czyszczenie  
Čištění

Čištění  
清洗  
Очистка  
Tisztítás  
Puhdistus

Rengöring  
Valymas  
Čišćenje  
Temizleme  
Curățare

Καθαρισμός  
Puhastamine  
Čišćenje  
Tirišana  
Čišćenje

Rengjøring  
Почистване  
Pastrimi  
التنظيف

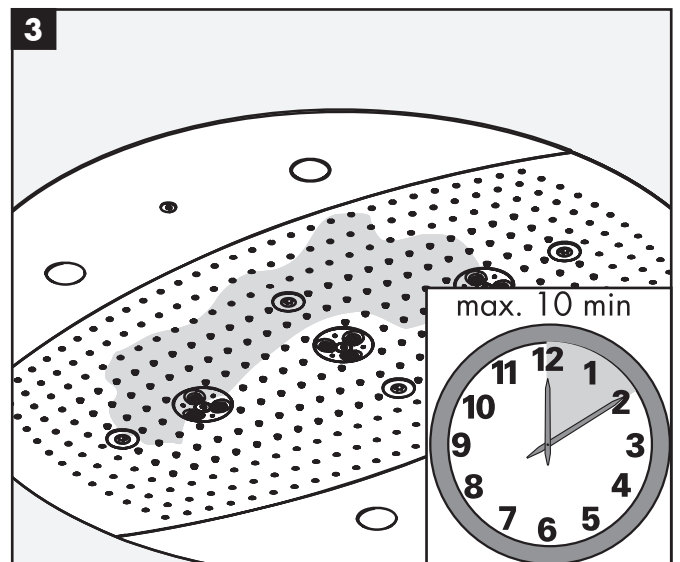
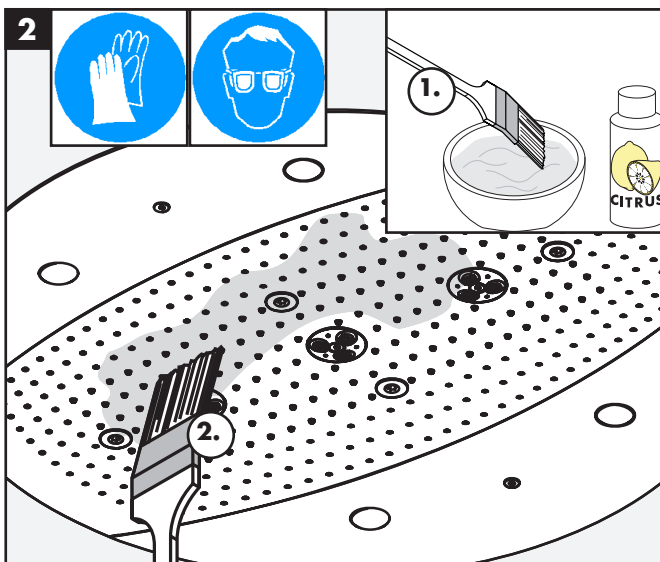
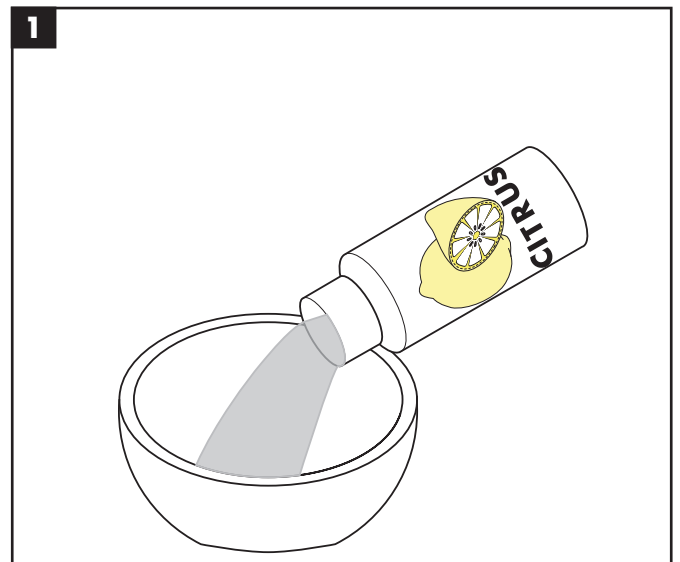
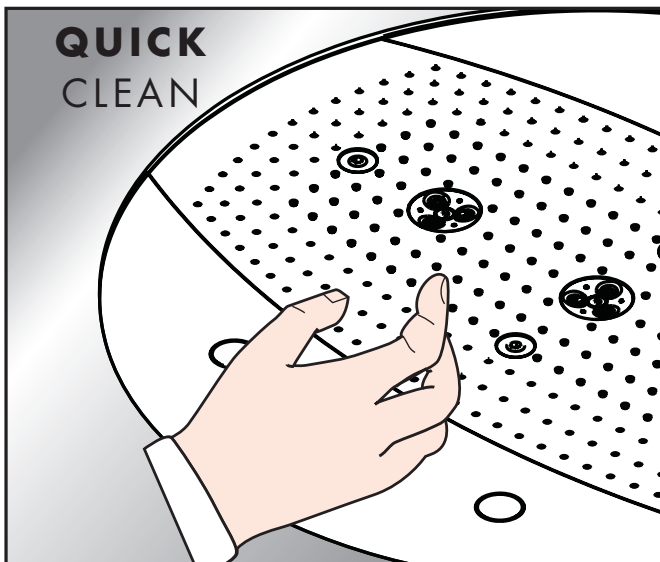

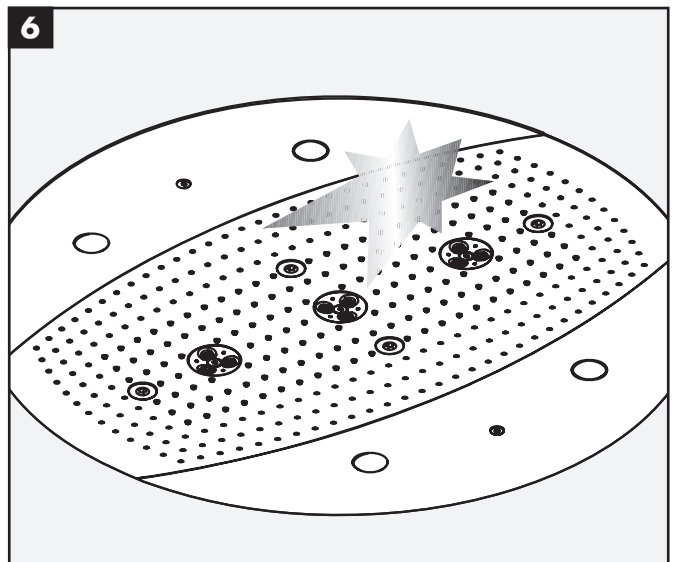
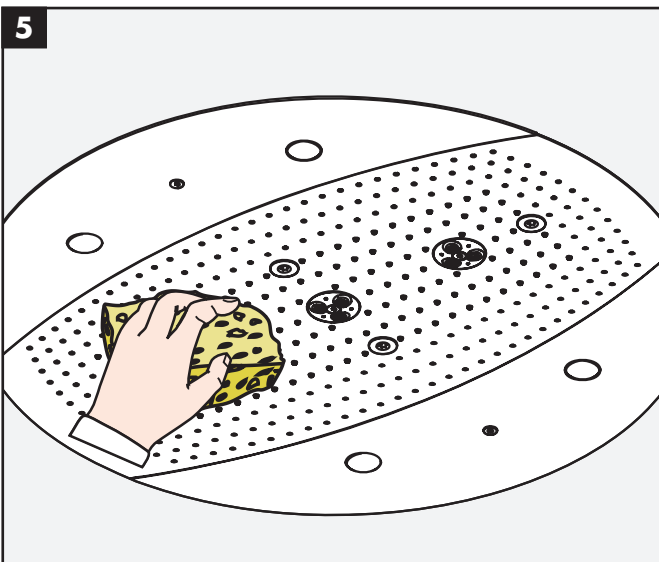
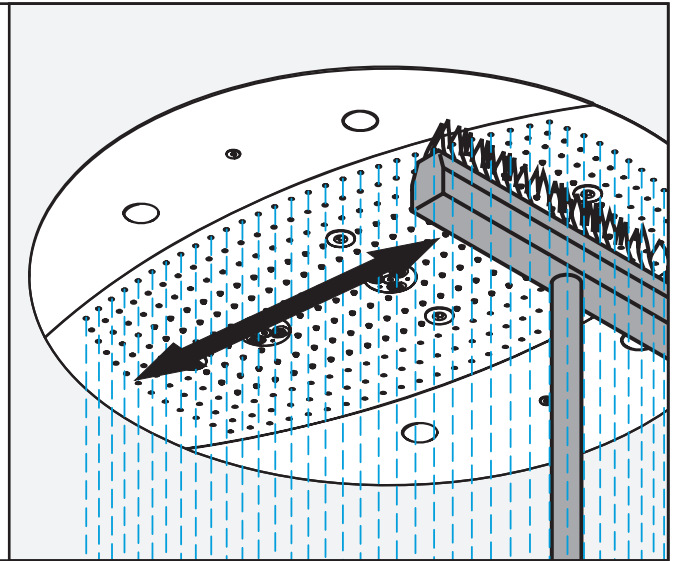
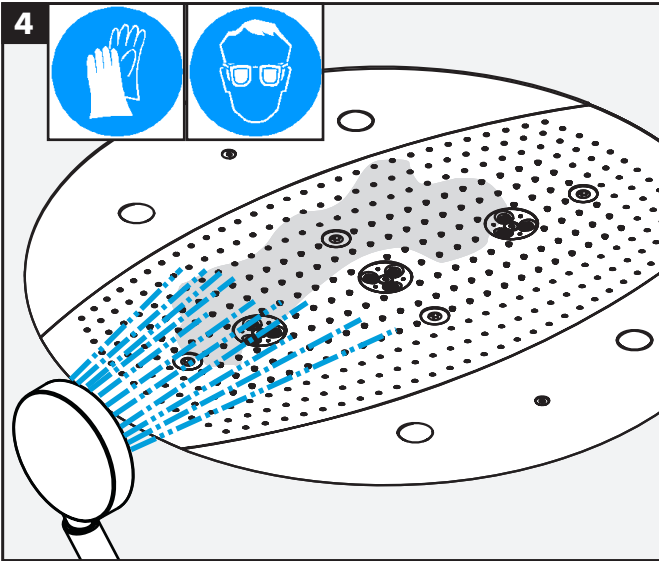
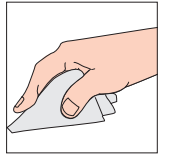

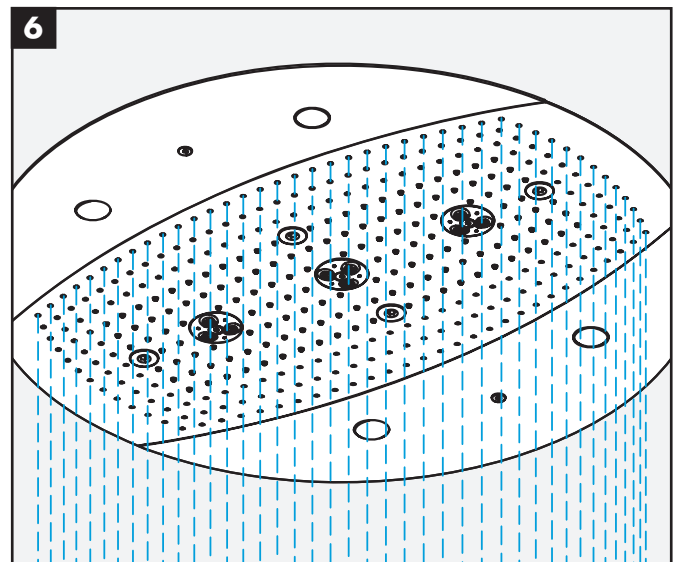
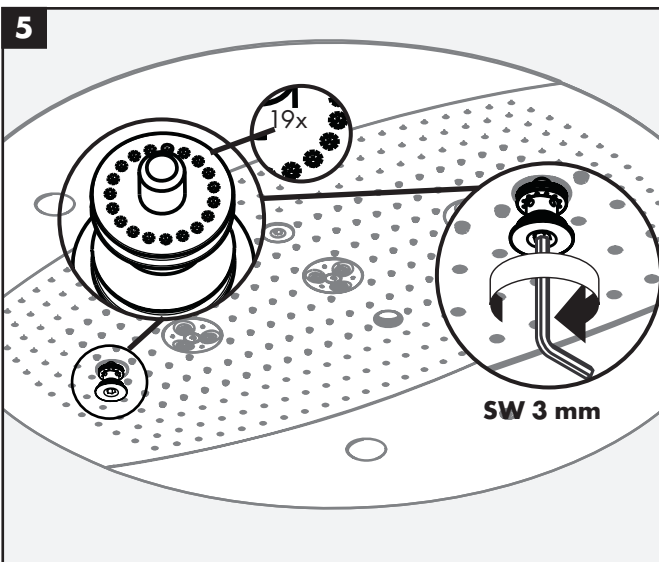
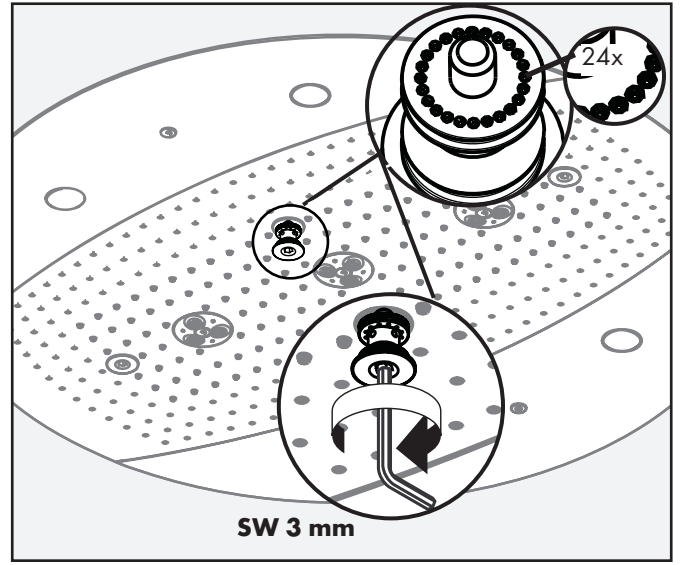
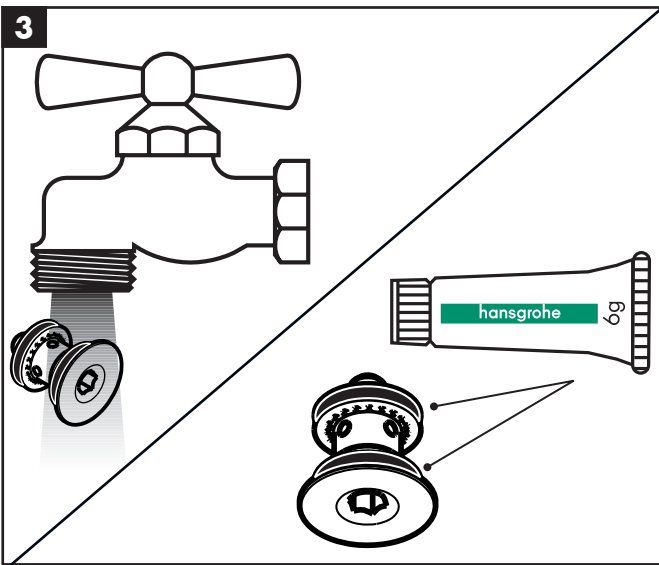
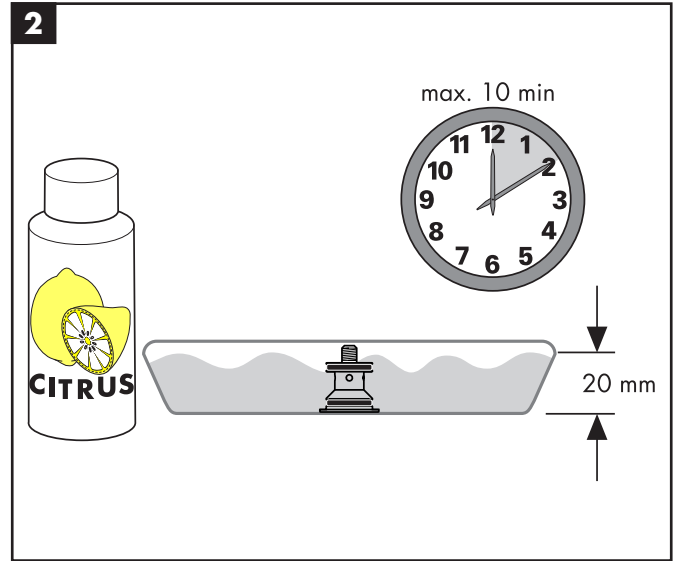
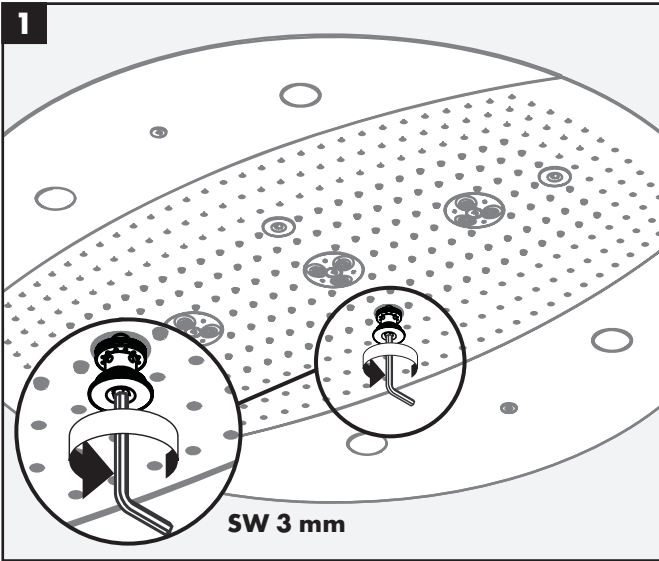
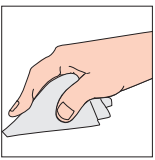

**hansgrohe**

Hansgrohe · Postfach 1145 · D-77761 Schiltach · Telefon +49 (0) 78 36/51-1282 · Telefax +49 (0) 7836/511440  
E-Mail: info@hansgrohe.com · Internet: www.hansgrohe.com

02/2011  
9.05718.06