

MARBLEMATE

(D)	MONTAGEANLEITUNG:	DUSCHWANNE AUS GUSSMARMOR
(GB)	INSTALLATION INSTRUCTIONS:	SHOWER TRAY OF CAST MARBLE
(F)	NOTICE DE MONTAGE:	RECEVEUR EN BETON DE SYNTHÈSE
(CZ)	NÁVOD K MONTÁŽI:	SPRCHOVÁ VANIČKA Z LITÉHO MRAMORU
(PL)	INSTRUKCJA MONTAŻU:	BRODZIK Z LITEGO MARMURU
(SK)	NÁVOD NA MONTÁŽ:	SPRCHOVÁ VANIČKA Z LIATEHO MRAMORU
(H)	SZERELÉSI ÚTMUTATÓ:	ÖNTÖTT MÁRVÁNY ZUHANYTÁL
(E)	INSTRUCCIONES DE MONTAJE:	BAÑERA DE DUCHA DE MÁRMOL COLADO

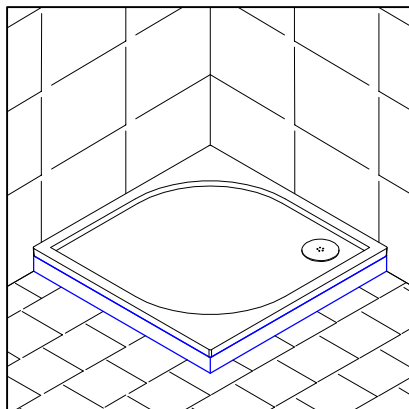
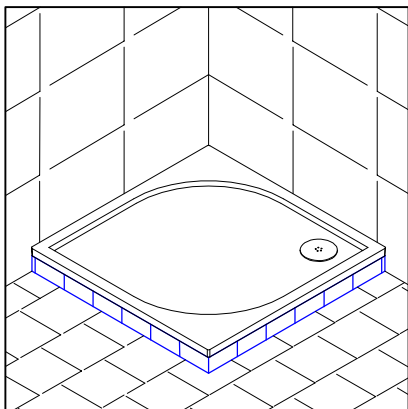
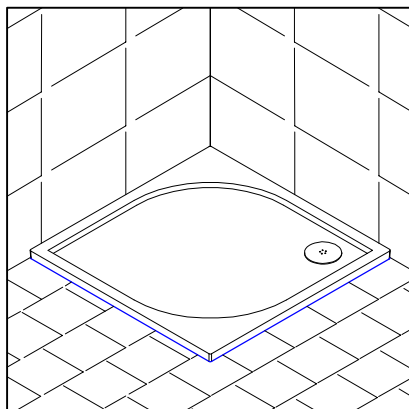
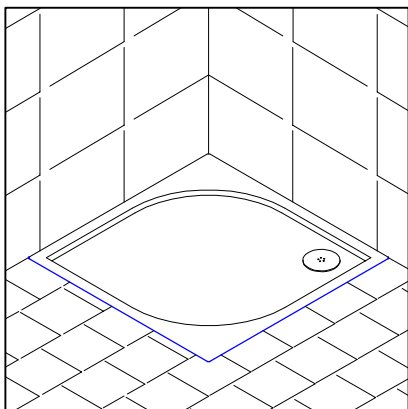

ERONAL®

Benötigtes Werkzeug:

Necessary tools:

Outil Nécessaire:

Nářadí potřebné pro montáž:

Potrzebne narzędzia:

Potrebné náradie:

Szükséges szerszámok:

Herramientas necesarias:

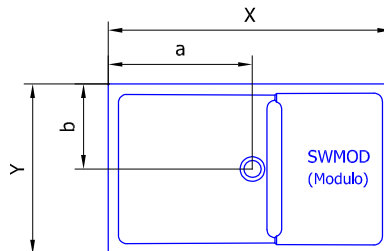
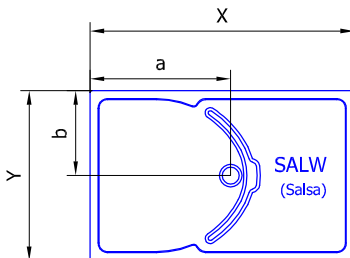
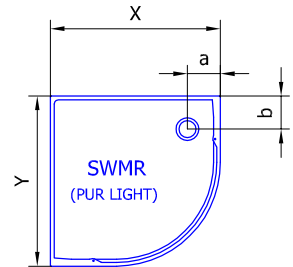
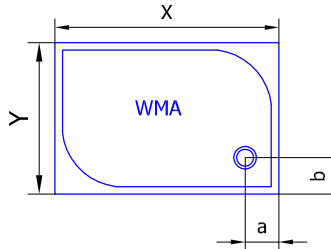
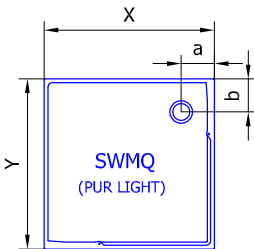
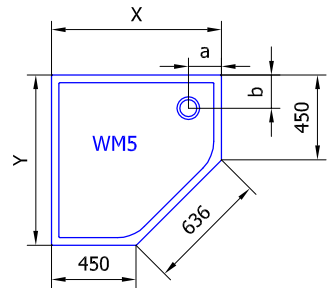
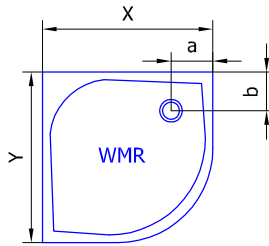
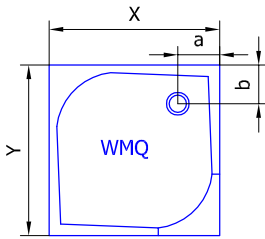
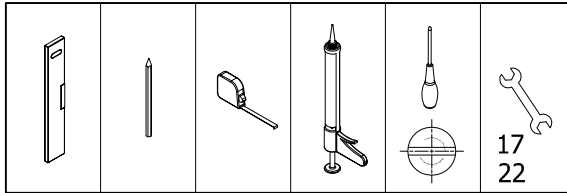

[mm]	X	Y	a	b	t
WMQ/WMR	800	800	150	150	30
	900	900	180	180	30
	1000	1000	WMR 180 WMQ 150	WMR 180 WMR 150	30
WMA	1000	800	150	150	30
	1200	800	150	150	30
	1400	800	150	150	30
SWMQ/SWMR	900	900	175	175	30
WM5	900	900	175	175	30
SWSAL	1400	900	745	450	35
SWMOD	1500	900	765	450	38

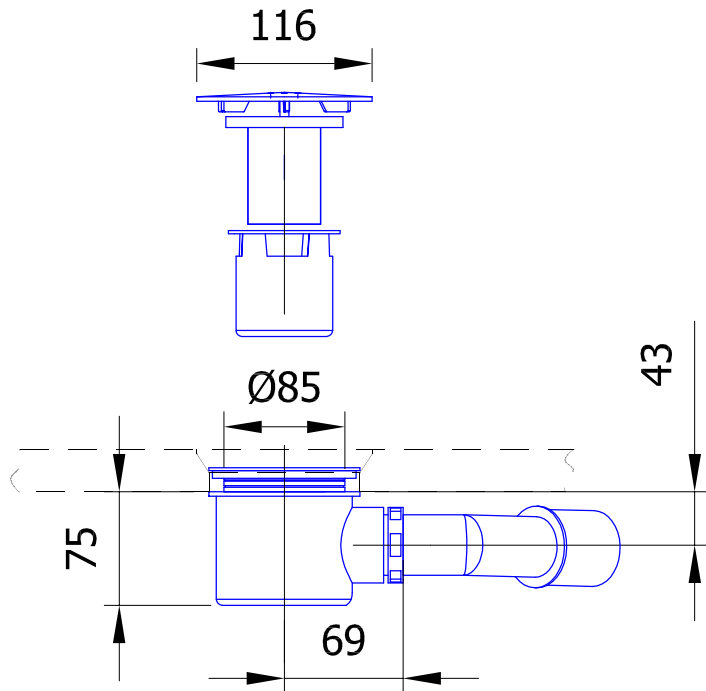

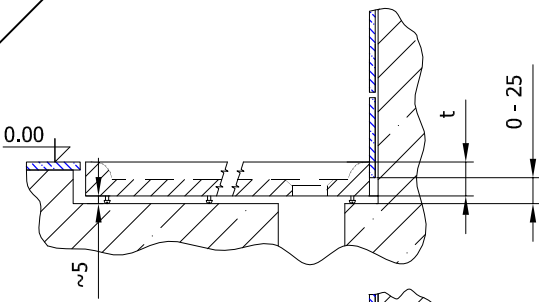

1.

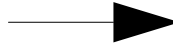
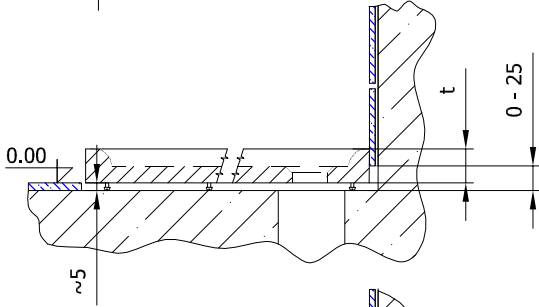

2.

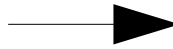
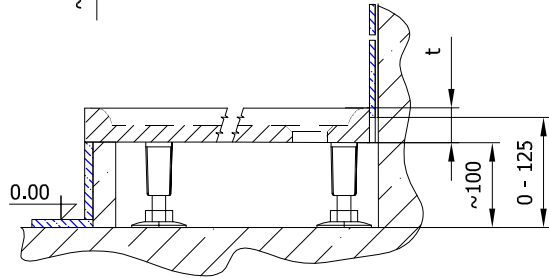

3.

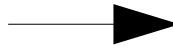
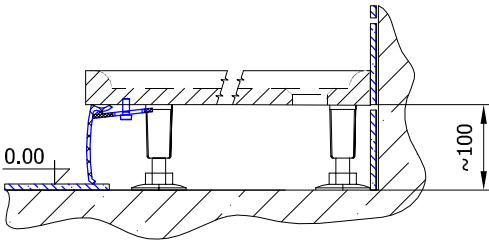

4.

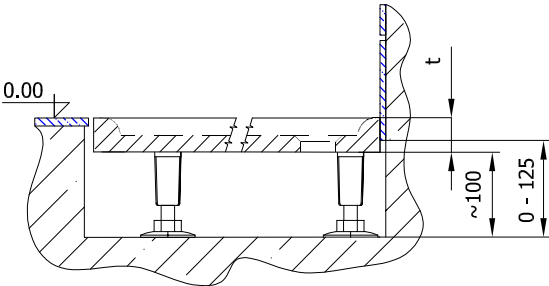

5.

WMP

SWMP

SWMQ

WMS

SWSAL

SWMOD

WMQ

WMA



TANGO
SWING
SWING F
JAZZ
PUR LIGHT
PUR LIGHT S
FUN

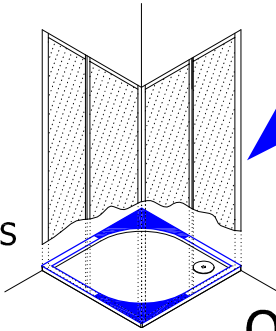

OK

PUR
MOBILE

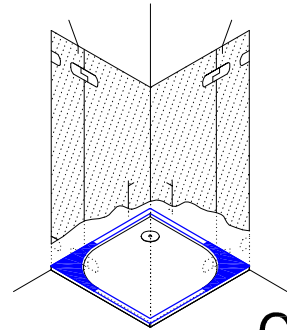
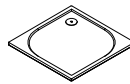
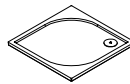
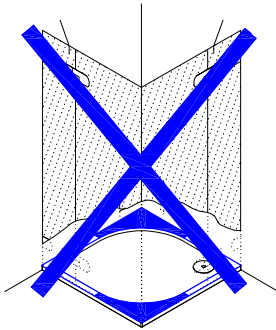

OK

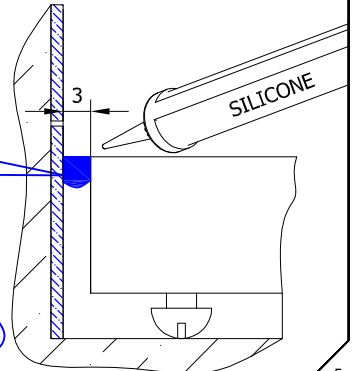
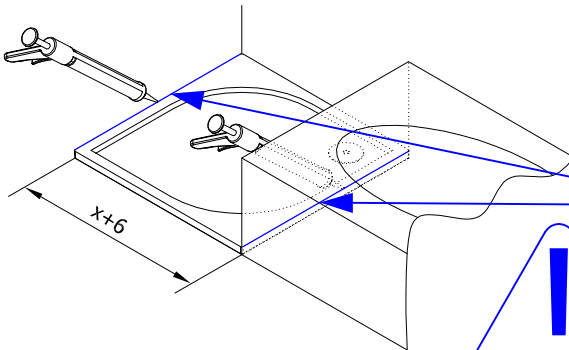

SILICONE

1.

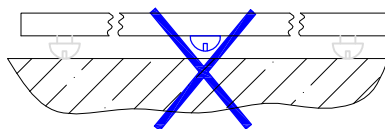
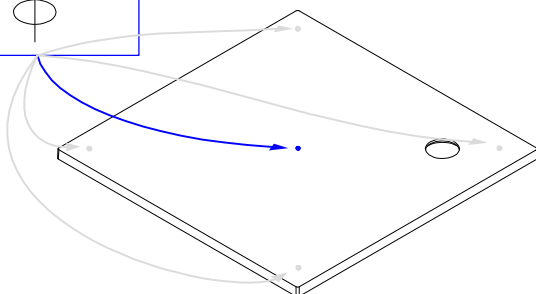
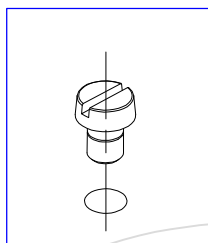
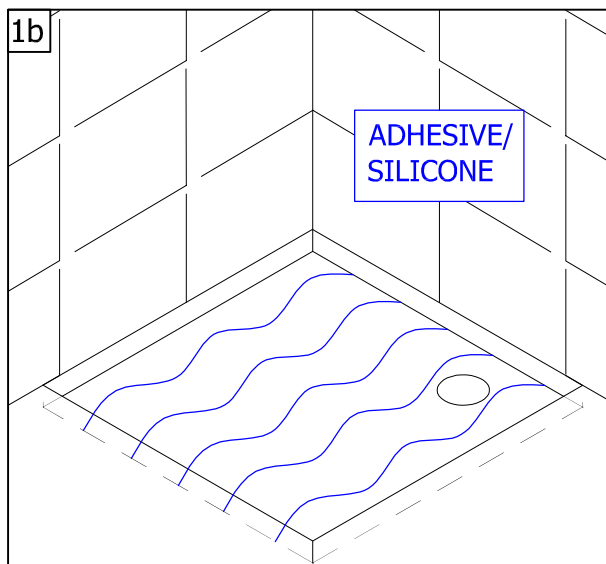
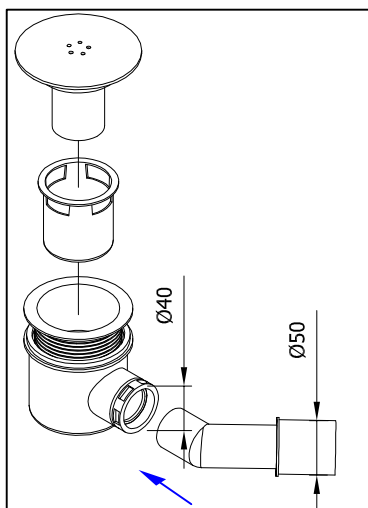
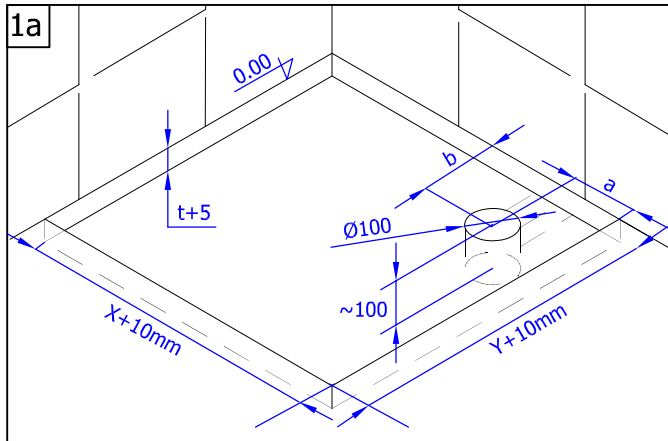

OK

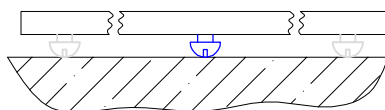

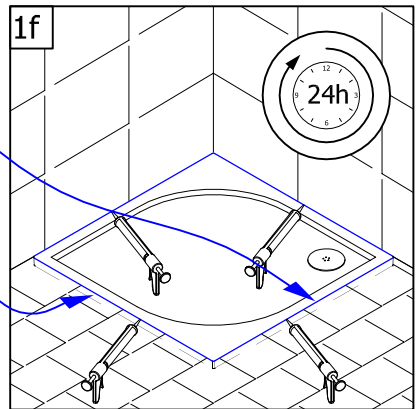
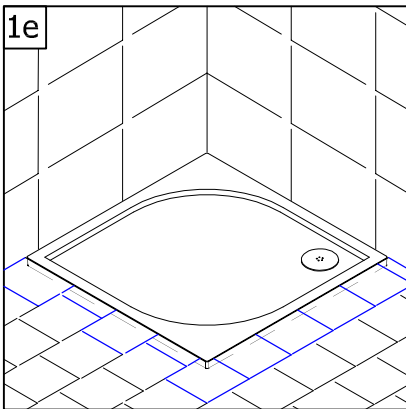
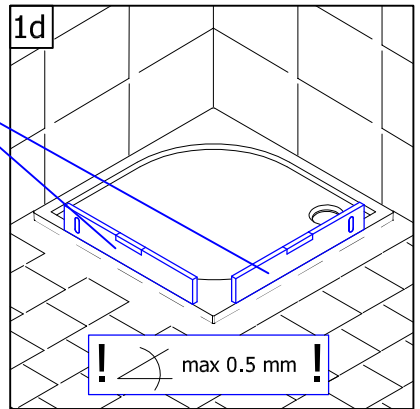
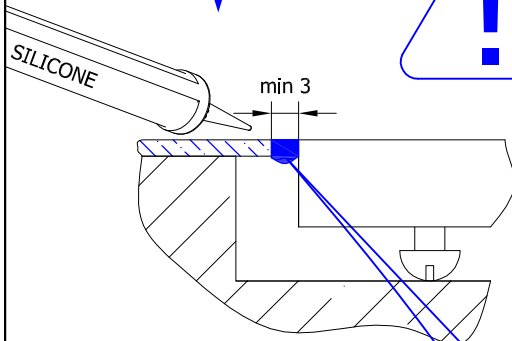
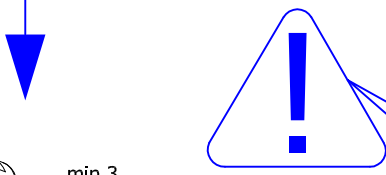
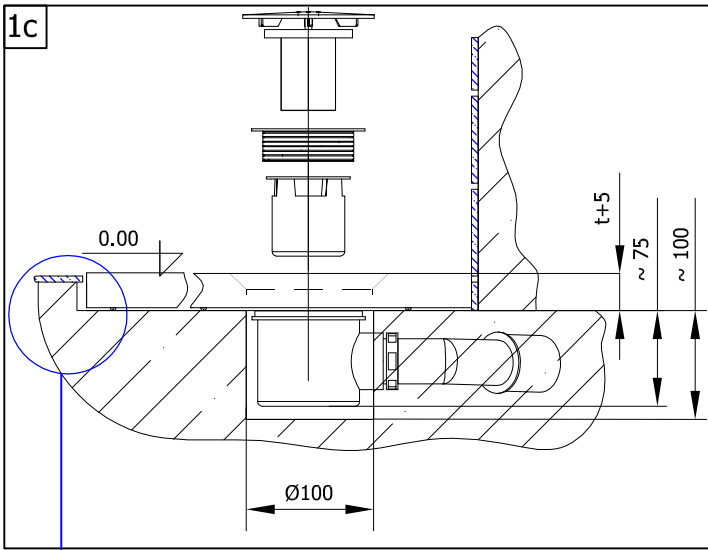

2.

2a

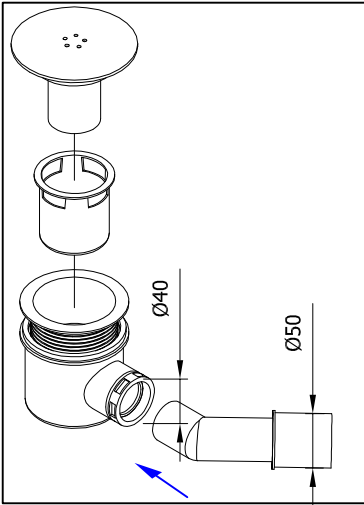
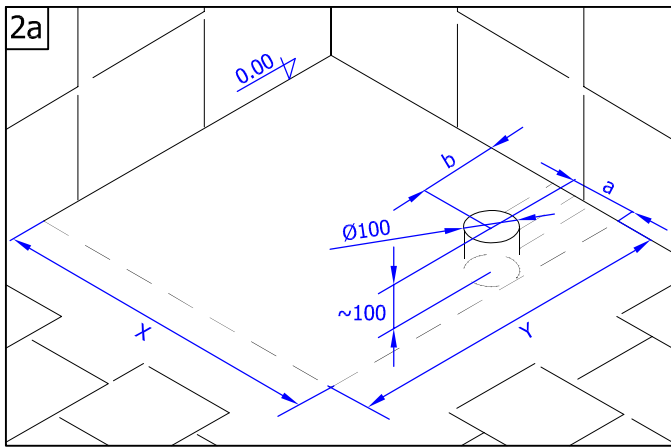

2b

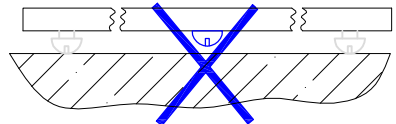
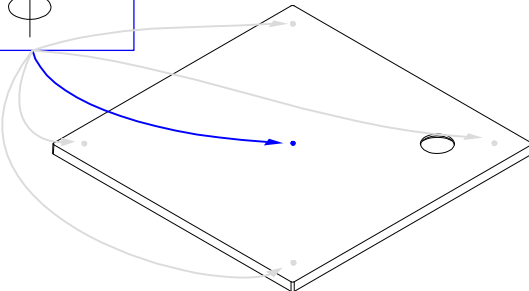
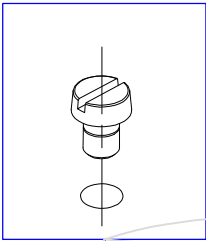
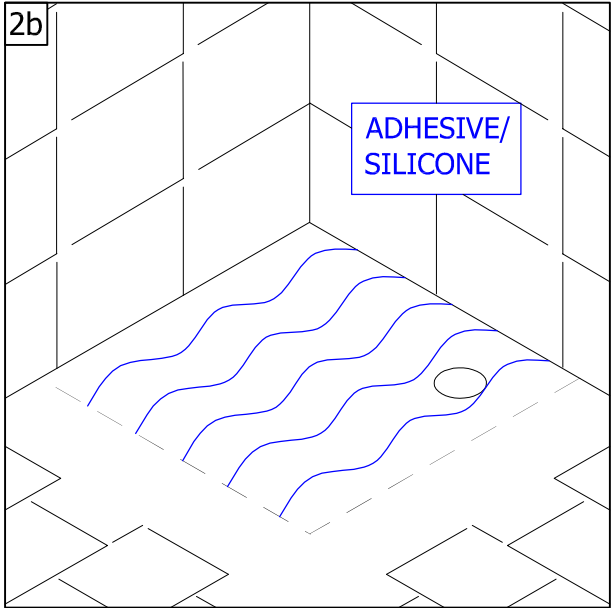

OK

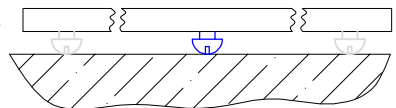

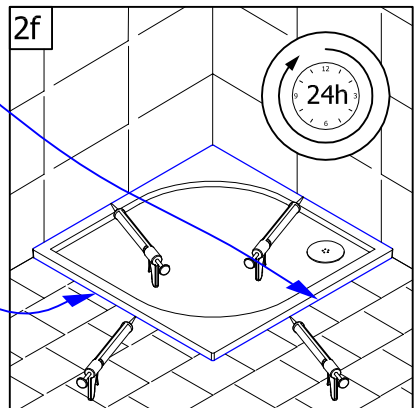
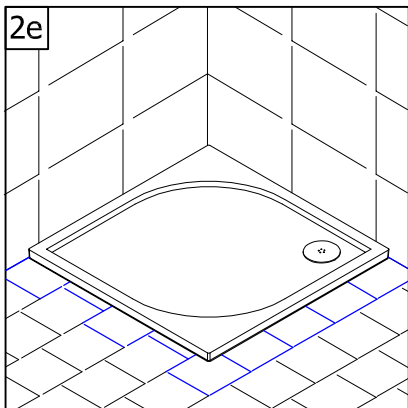
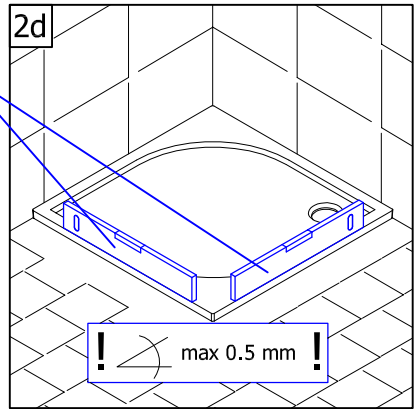
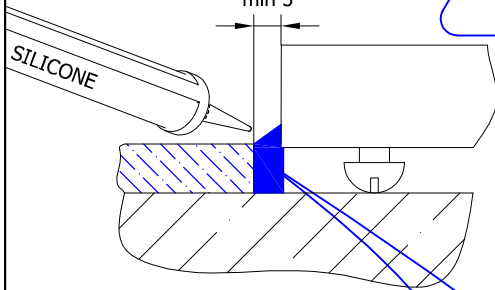
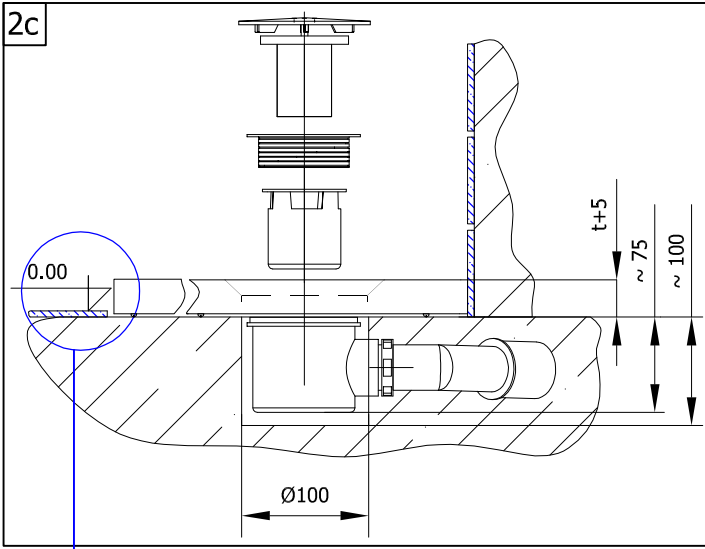

3.

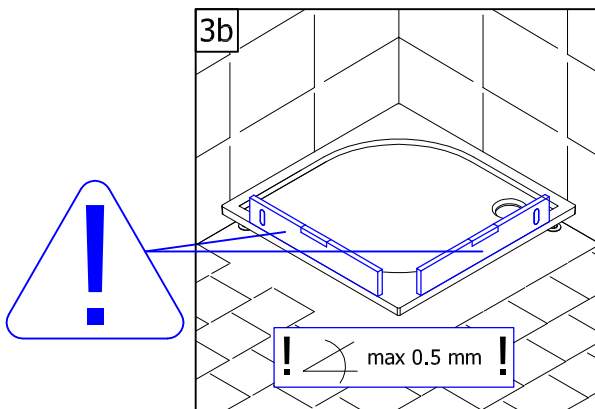
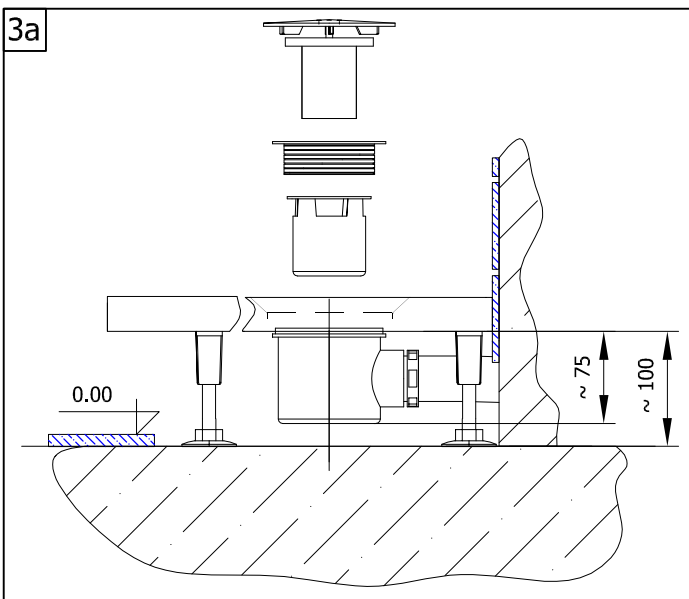
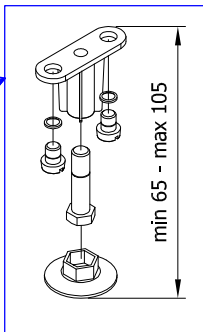
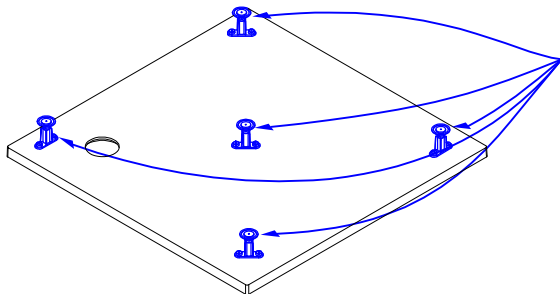

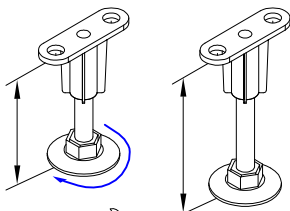
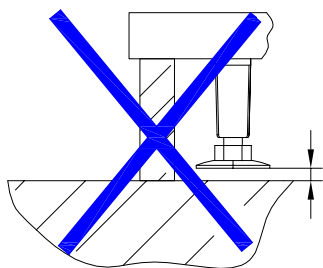

22

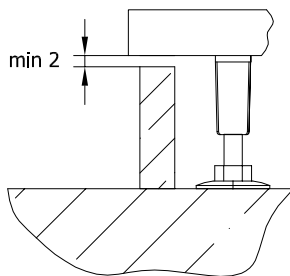

OK

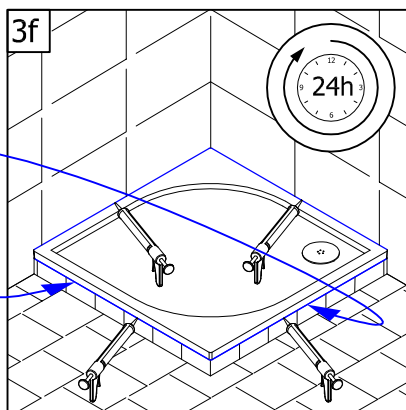
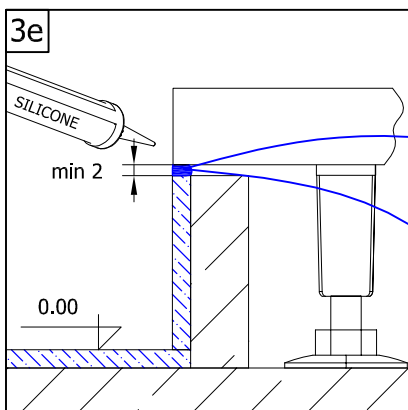
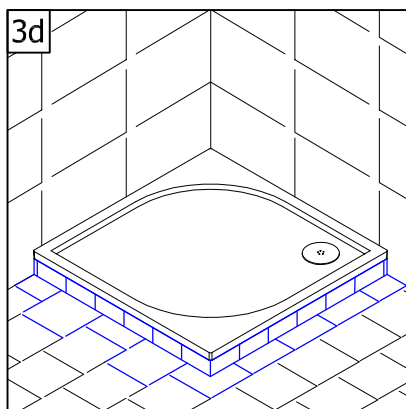
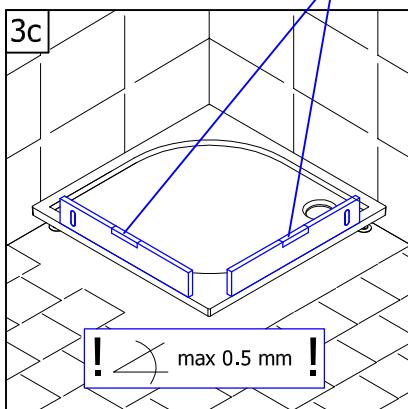

4.

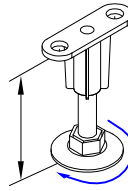
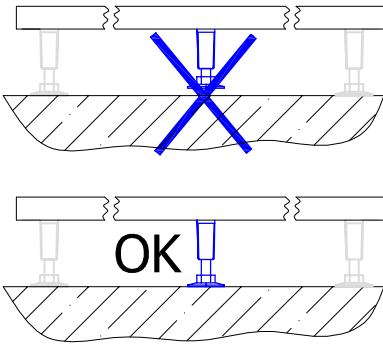
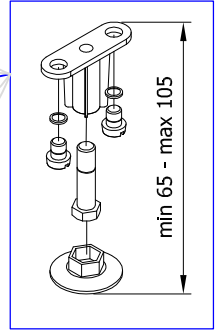
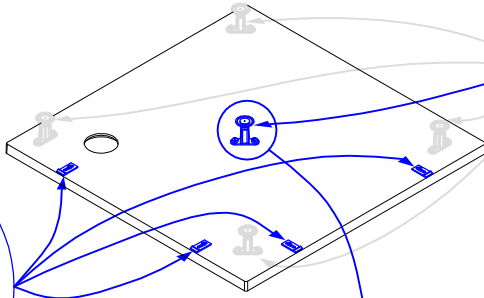
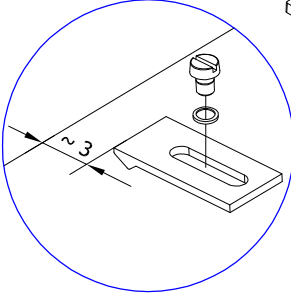

22

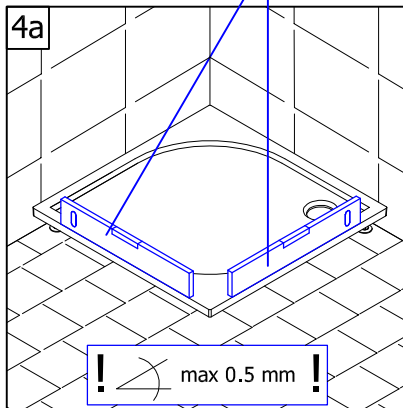
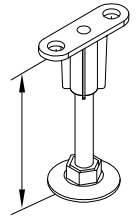

4b

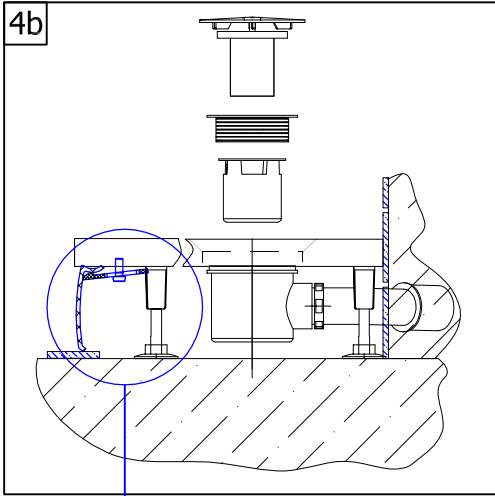

4c

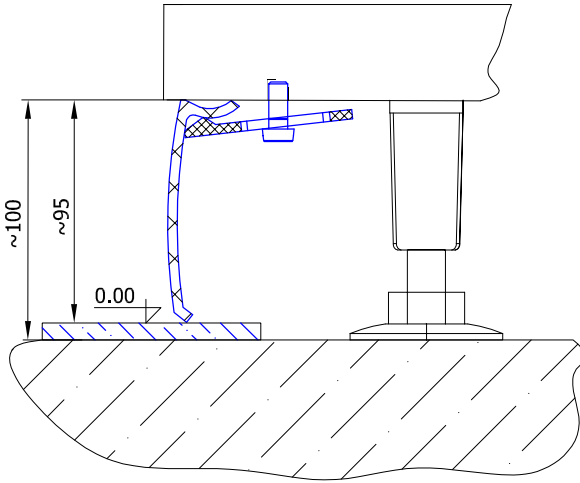
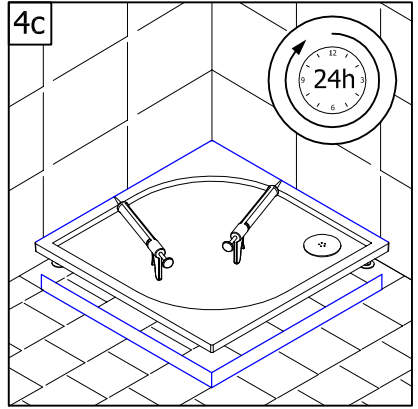

5.

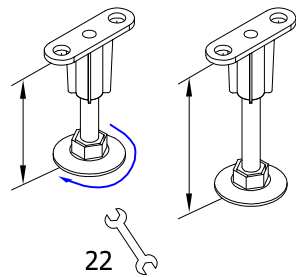
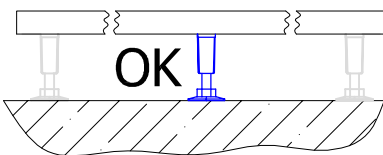
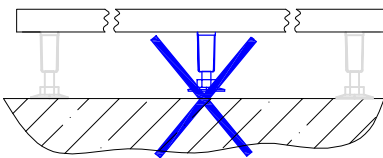
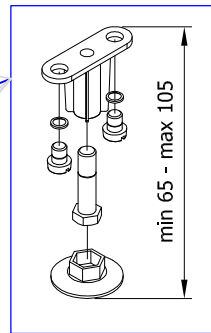
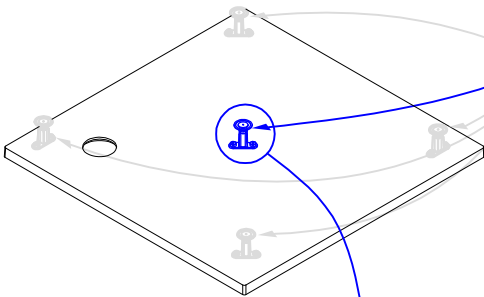
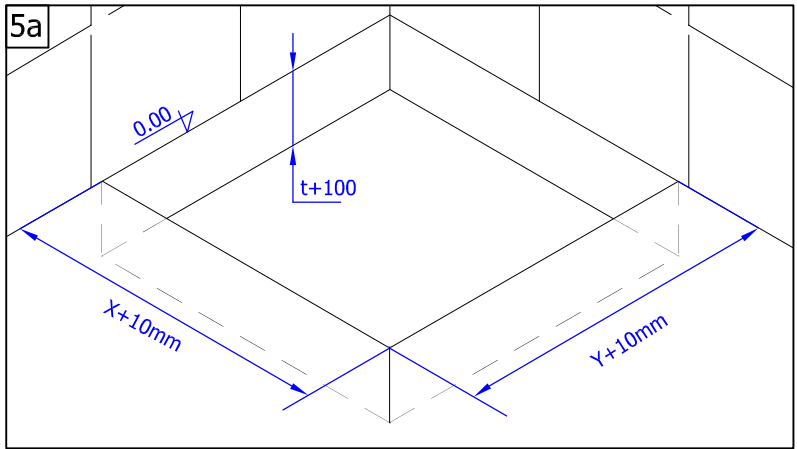

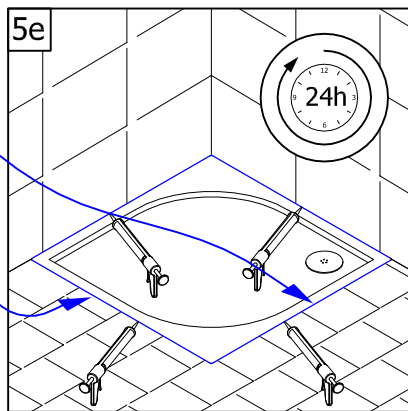
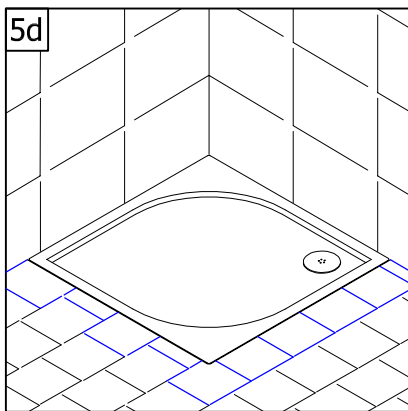
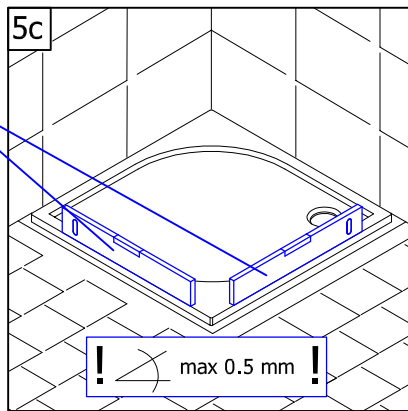
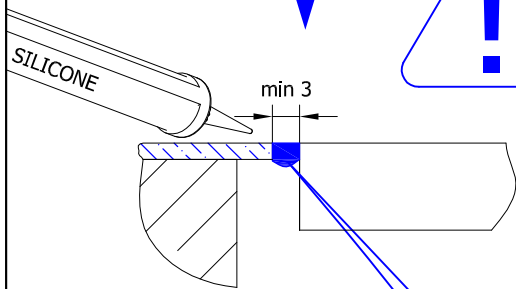
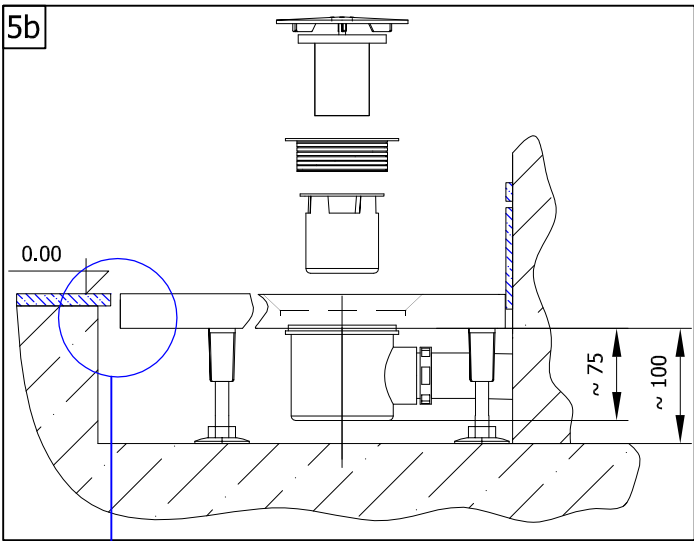

QUALITY CONTROL:

- D** Falls Sie Reklamationen haben, oder Sie unzufrieden mit Ihrem RONAL Produkt sind, beschreiben Sie bitte unten auf diesem Blatt den Produktfehler und übergeben Sie dieses Dokument Ihrem Verkäufer, oder direkt der Firma RONAL. Diese Information hilft uns, die Qualität von unseren Produkten weiter zu verbessern.
- GB** In case of a complaint or Your dissatisfaction with the RONAL product, please describe the defect below and pass this document to Your vendor, or directly to the RONAL company. This information will help us in the next increase of the quality of our products.
- F** En cas de réclamations lors de la livraison ou l'installation de votre paroi de douche RONAL, veuillez, s'il vous plaît, noter vos remarques au bas de la feuille et transmettre les informations à votre revendeur. Elles nous permettront d'améliorer notre qualité et par la même notre service.
- CZ** V případě reklamace, či Vaší nespokojenosti s výrobkem RONAL popište prosím ve spodní části tohoto listu závadu a dokument prosím odevzdejte Vašemu prodejci nebo přímo firmě RONAL. Tato informace nám pomůže v dalším zvýšení kvality našich výrobků.
- PL** Reklamacje , oraz inne niezgoności związane z produktem RONAL prosimy przekazywać sprzedawcy na załącznym druku.
- SK** V prípade reklamácie, alebo Vašej nespokojnosti s výrobkom RONAL, popíšte prosím v spodnej časti tohto listu závalu a dokument prosím odovzdajte Vašemu prodejci, alebo priamo firme RONAL. Táto informácia nám pomôže v ďalšom zvýšení kvality našich výrobkov.
- H** Abban az esetben ha reklamációja vagy panasza van az Ön által vásárolt RONAL termékkel, úgy azt írja meg a lap alján található helyre és adja át a kereskedőjének, vagy küldje el közvetlenül a RONAL cégnek! Ez az információ segít nekünk termékeink minőségének javításában.
- E** En caso de reclamaciones ó si no está satisfecho con su producto RONAL, por favor describan en la parte inferior de esta hoja el fallo del producto y entreguen este documento a su vendedor ó directamente a la empresa RONAL. Esta información nos ayuda a seguir mejorando la calidad de nuestros productos.

.....

.....

.....

.....

.....

.....

.....

.....

.....

.....