



BOSCH

Winkelschleifer

GWS 17-150 S | 3 601 GD0 600

Inhaltsverzeichnis

Abbildung - Typ.....2

Abbildung - Typ - E



Abbildung - Typ - E

3 601 GD0 600

Stand } 22-03-18
Issue } 22-03-18 **Fig./Abb. 2**

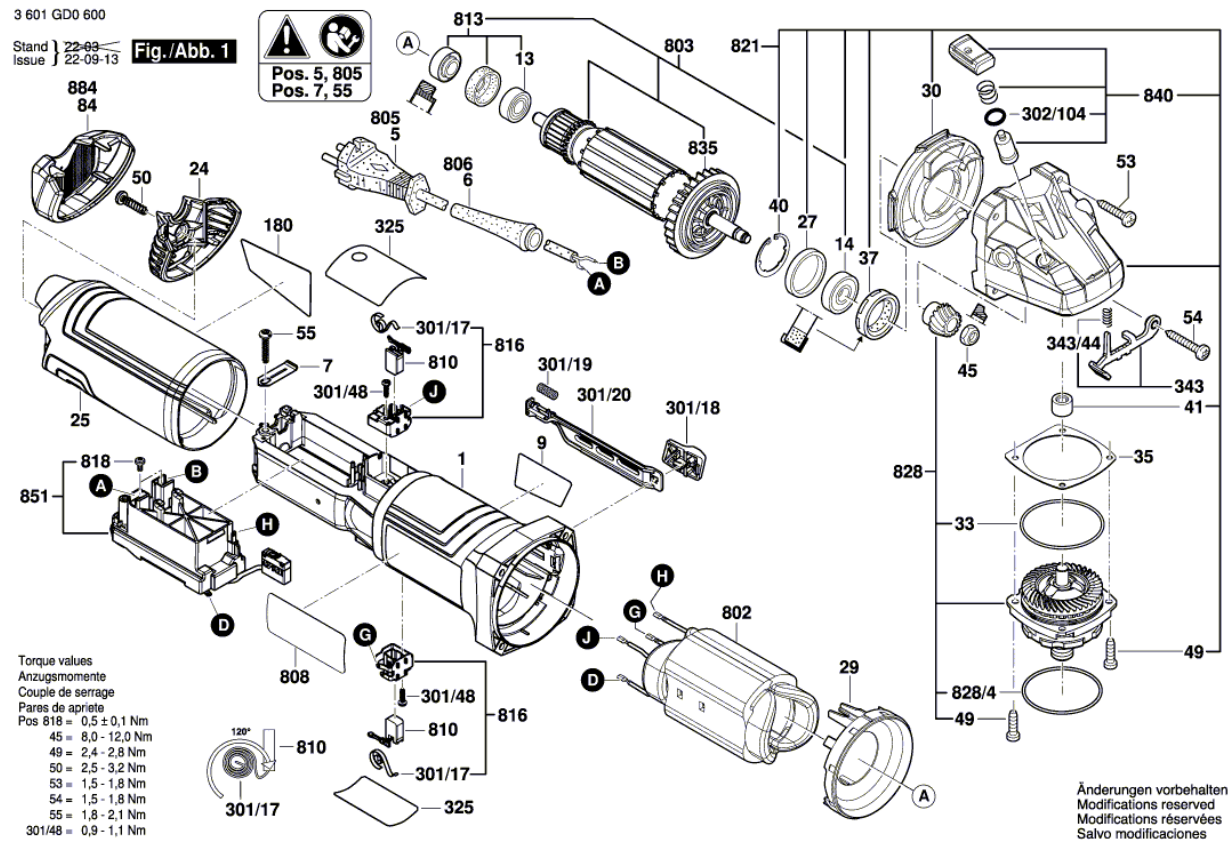
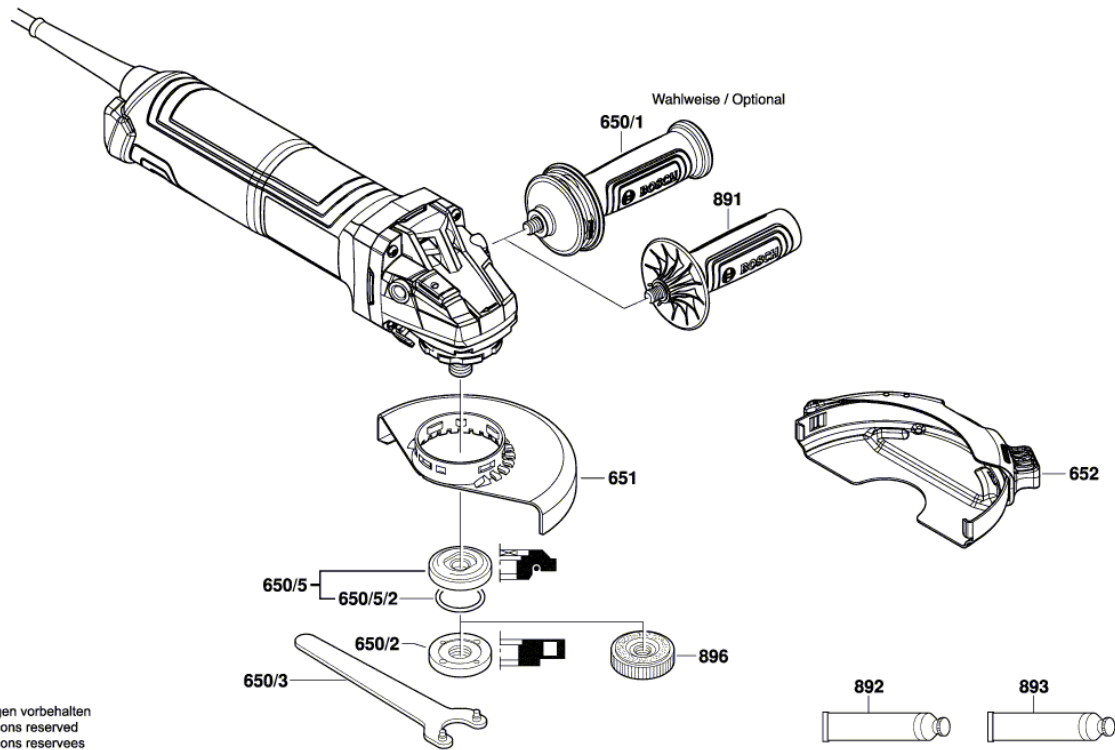

Änderungen vorbehalten
Modifications reserved
Modificaciones reservadas
Salvo modificaciones