



BOSCH

Winkelschleifer

GWX 14-125 S | 3 601 GD2 100

Inhaltsverzeichnis

Abbildung - Typ.....2

Abbildung - Typ - E



Abbildung - Typ - E

3 601 GD2 100

Stand } 22-03-23 **Fig./Abb. 2**
Issue }

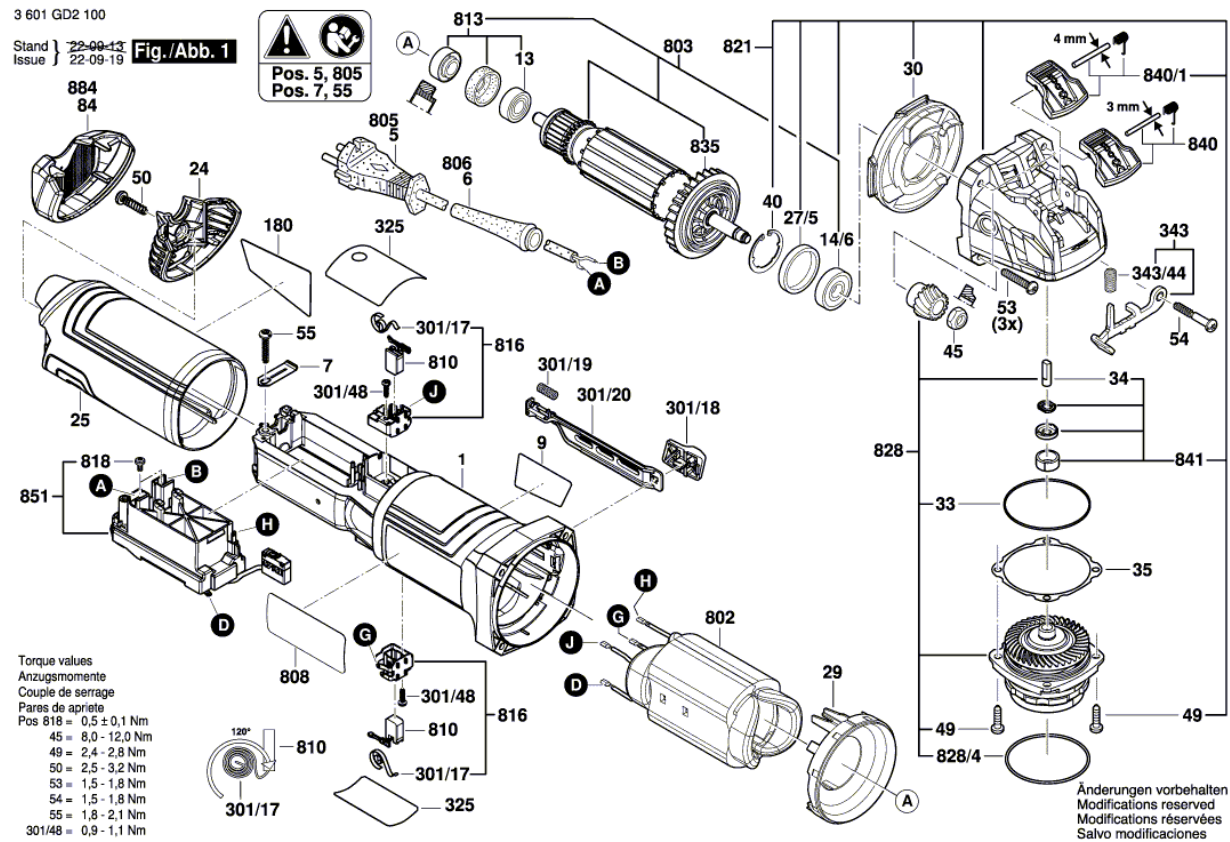
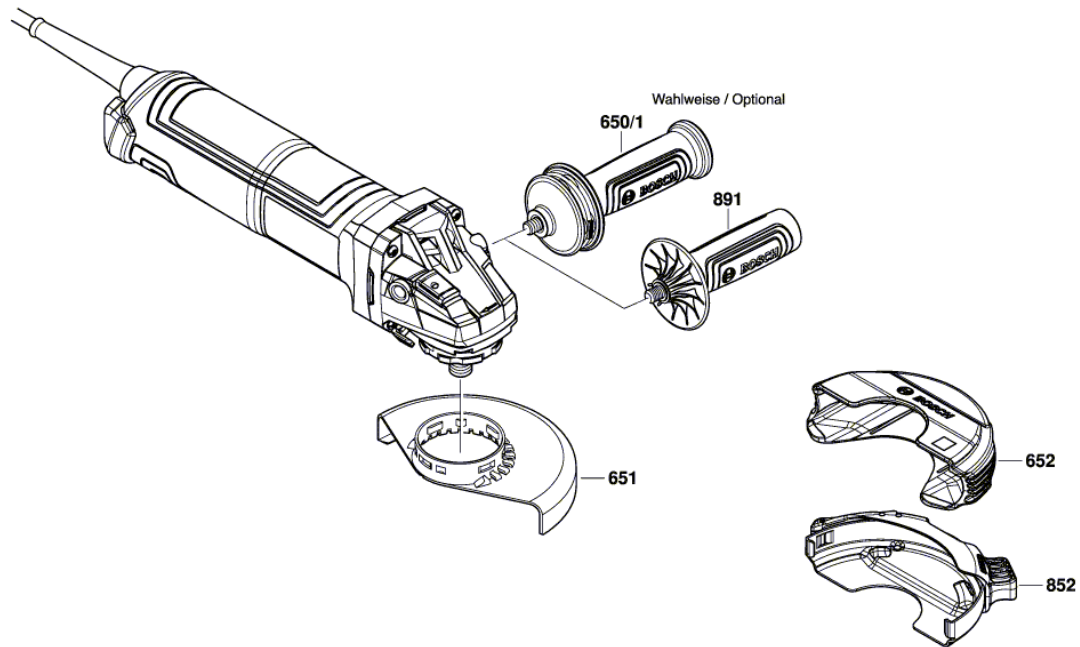

Änderungen vorbehalten
Modifications reserved
Modifications réservées
Salvo modificaciones