

## ELECTRIC TOOL PARTS LIST

### CHAIN SAW Model CS 40Y

2013·4·17  
(E1)

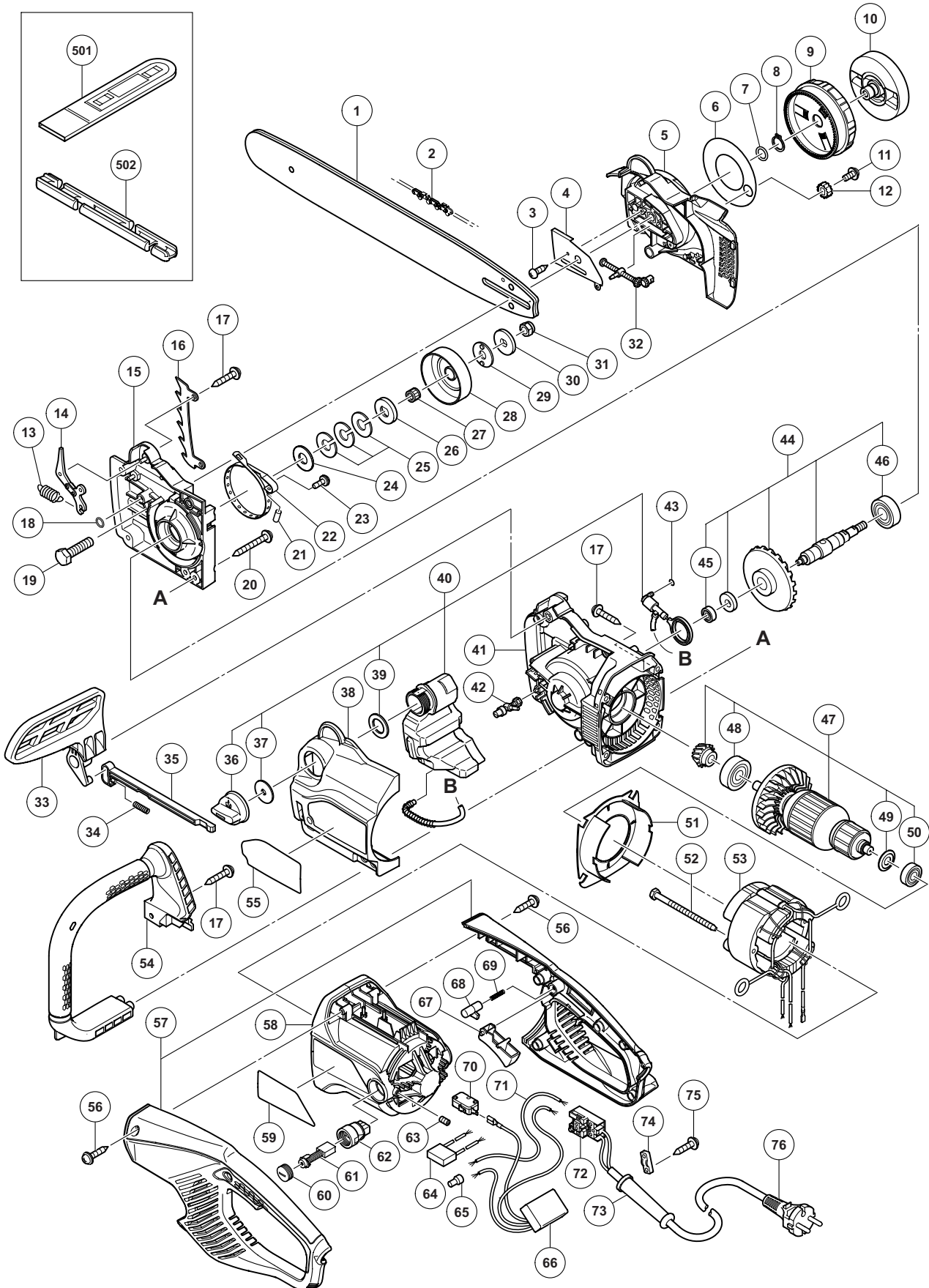

**PARTS**

CS 40Y

ITEM NO.	CODE NO.	DESCRIPTION	NO. USED	REMARKS
1	669-6992	CHAIN BAR 16 INCH 3/8 SPROCKET PRC	1	
2	669-7889	SAW CHAIN (3/8 X 16") 91PX-57XJ	1	
3	696-352	TAPPING SCREW D3	2	
4	335-471	GUIDE PLATE	1	
5	335-470	SIDE COVER (R)	1	
6	335-688	DUST SHEET	1	
7	996-407	O-RING (1AP-12)	1	
8	939-543	RETAINING RING FOR D14 SHAFT (10 PCS.)	1	
9	335-150	TENSION DIAL	1	
10	335-151	KNOB	1	
11	315-500	MACHINE SCREW (W/WASHER) M4 X 8 (BLACK)	1	
12	335-152	TENSION GEAR	1	
13	668-5389	BRAKE SPRING	1	
14	669-8587	BRAKE LINK	1	
15	335-472	INNER COVER	1	
16	335-482	SPIKE BAR	1	
17	305-558	TAPPING SCREW (W/FLANGE) D5 X 25 (BLACK)	8	
18	997-218	O-RING (S-6)	1	
19	949-678	BOLT M8 X 35 (10 PCS.)	1	
20	325-336	TAPPING SCREW D5 X 55	2	
21	668-5391	NEEDLE ROLLER D3	1	
22	668-5390	BRAKE BAND	1	
23	935-196	MACHINE SCREW (W/WASHERS) M4 X 12 (BLACK)	1	
24	335-484	WASHER (E)	1	
25	335-485	SPRING WASHER	3	
26	335-486	COLLAR (B)	1	
27	668-5361	NEEDLE BEARING (D)	1	
28	668-5403	CLUTCH HOUSING	1	
29	335-487	WASHER (C)	1	
30	335-488	WASHER (D)	1	
31	975-348	NYLON NUT M8	1	
32	335-966	CHAIN PULLEY	1	
33	335-479	BRAKE HANDLE	1	
34	335-483	SPRING (C)	1	
35	335-480	SWITCH ROD	1	
36	335-144	TANK CAP	1	
37	335-691	TANK CAP PACKING	1	
38	335-477	SIDE COVER (L)	1	
39	335-490	GASKET	1	
40	335-474	OIL PUMP ASS'Y	1	INCLUD. 36, 37, 39
41	335-476	GEAR CASE	1	
42	335-967	ADJUSTING BOLT	1	
43	981-317	O-RING (S-4)	1	
44	335-473	SPINDLE GEAR ASS'Y	1	INCLUD. 45, 46
45	606-ZZM	BALL BEARING 606VVC2	1	
46	620-2VV	BALL BEARING 6202VVCMP2L	1	
* 47	360-957U	ARMATURE AND PINION SET 110 V-120 V	1	INCLUD. 48-50
* 47	360-957E	ARMATURE AND PINION SET 220 V-230 V	1	INCLUD. 48-50
48	630-1VV	BALL BEARING 6301VVCMP2L	1	
49	302-428	WASHER (A)	1	

PARTS

CS 40Y

ITEM NO.	CODE NO.	DESCRIPTION	NO. USED	REMARKS	
	50	600-0VV BALL BEARING 6000VVCMP2L	1		
	51	335-481 FAN GUIDE	1		
	52	953-121 HEX. HD. TAPPING SCREW D5 X 50	2		
*	53	340-863C STATOR ASS'Y 110 V-120 V	1		
*	53	340-864E STATOR ASS'Y 220 V-230 V	1		
*	53	340-863E STATOR ASS'Y 220 V-230 V	1	FOR IND, ISR	
	54	335-478 FRONT HANDLE	1		
*	55	335-466 CAUTION LABEL	1		
*	55	335-467 CAUTION LABEL	1	FOR USA, CAN	
	56	307-811 TAPPING SCREW (W/FLANGE) D4 X 16 (BLACK)	7		
	57	335-475 HANDLE SET	1		
	58	335-469 HOUSING ASS'Y	1	INCLUD. 62, 63	
	59		1	NAME PLATE	
	60	945-161 BRUSH CAP	2		
*	61	999-065 CARBON BRUSH (1 PAIR)	2		
*	61	999-038 CARBON BRUSH (1 PAIR)	2	FOR USA, CAN	
	62	938-241 BRUSH HOLDER	1		
	63	938-477 HEX. SOCKET SET SCREW M5 X 8	1		
*	64	335-462 NOISE SUPPRESSOR	1	EXCEPT FOR USA, CAN, IND, ISR	
	65	959-141 CONNECTOR 50092 (10 PCS.)	1		
*	66	335-454 CONTROLLER 100 V-127 V	1		
*	66	335-455 CONTROLLER 200 V-240 V	1		
	67	335-463 TRIGGER	1		
	68	335-464 OFF LOCK BUTTON	1		
	69	335-465 SPRING (A)	1		
	70	335-460 MICRO SWITCH	1		
	71	335-461 INTERNAL WIRE	1		
	72	335-453 SWITCH	1		
*	73	953-327 CORD ARMOR D8.8	1		
*	73	938-051 CORD ARMOR D10.1	1		
	74	937-631 CORD CLIP	1		
	75	984-750 TAPPING SCREW (W/FLANGE) D4 X 16	2		
*	76	335-458 CORD (HOL)	1	(CORD ARMOR D8.8)	
*	76	335-459 CORD (HOL)	1	(CORD ARMOR D8.8) FOR RUS	
*	76	335-457 CORD (USA)	1	(CORD ARMOR D10.1) FOR USA, CAN	

