

ELECTRIC TOOL PARTS LIST

■ ROTARY HAMMER Model DH 52ME

2015-5-13
(E1)

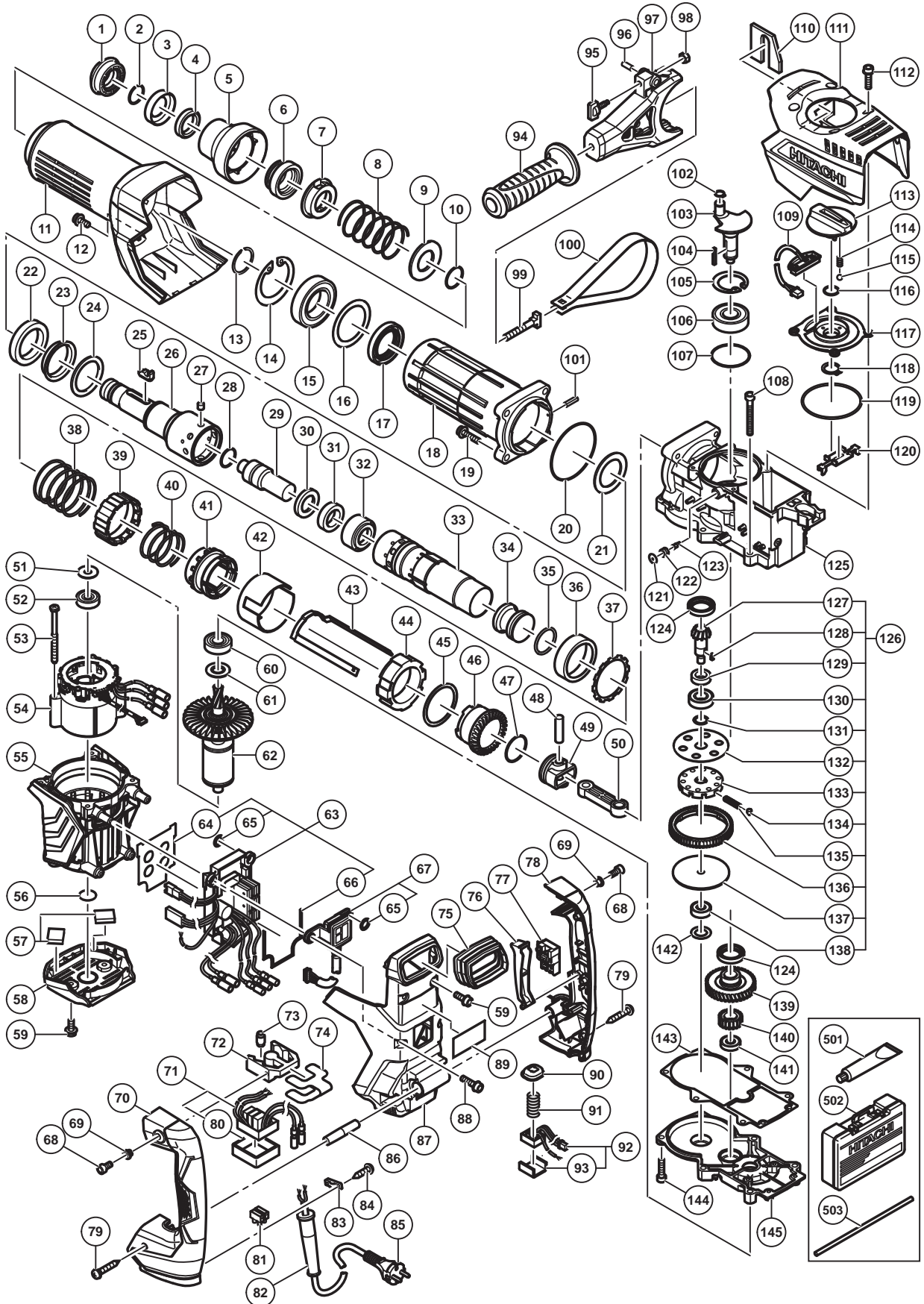

PARTS

DH 52ME

ITEM NO.	CODE NO.	DESCRIPTION	NO. USED	REMARKS
1	337562	FRONT CAP	1	
2	318590	STOPPER RING	1	
3	338155	RETAINER WASHER	1	
4	339053	RETAINER DAMPER (A)	1	
5	338154	GRIP	1	
6	338153	BIT LOCK HOLDER	1	
7	339051	THRUST PLATE	1	
8	339052	RETAINER SPRING	1	
9	337557	SPRING HOLDER (A)	1	
10	872470	O-RING (S-26)	1	
11	338198	CYLINDER CASE COVER	1	
12	998471	HEX. SOCKET HD. BOLT (W/FLANGE) M5 X 12	1	
13	318582	RETAINING RING D40	1	
14	338200	RETAINING RING D68	1	
15	339063	BALL BEARING 6008DDUCM	1	
16	338201	BEARING WASHER	1	
17	318588	OIL SEAL (NBR710)	1	
18	338199	CYLINDER CASE	1	
19	990083	HEX. SOCKET HD. BOLT (W/FLANGE) M8 X 35	4	
20	338222	O-RING (C)	1	
21	338204	RETAINER DAMPER HOLDER	1	
22	338203	RETAINER DAMPER (B)	1	
23	339064	DAMPER SLEEVE	1	
24	338202	RETAINER DAMPER WASHER	1	
25	337554	BIT LOCK	2	
26	338205	RETAINER SLEEVE	1	
27	338210	NEEDLE PIN D8	8	
28	986104	O-RING	1	
29	338206	SECOND HAMMER	1	
30	338207	DAMPER WASHER	1	
31	328887	DAMPER	1	
32	338208	DAMPER HOLDER	1	
33	338209	CYLINDER	1	
34	338214	STRIKER	1	
35	328880	O-RING	1	
36	338211	SPRING HOLDER (B)	1	
37	338216	LOCK SPRING WASHER	1	
38	338217	LOCK SPRING	1	
39	338215	LOCK SLEEVE	1	
40	338212	CLUTCH SPRING	1	
41	338213	CLUTCH	1	
42	338218	SLEEVE	1	
43	338235	SLIDER	1	
44	338219	METAL (A)	1	
45	338220	METAL WASHER	1	
46	338221	BEVEL GEAR	1	
47	328880	O-RING	1	
48	338228	PISTON PIN	1	
49	328877	PISTON	1	
50	328878	CONNECTING ROD	1	

PARTS

DH 52ME

ITEM NO.	CODE NO.	DESCRIPTION	NO. USED	REMARKS
51	944954	BEARING WASHER	1	
52	6201VV	BALL BEARING 6201VVCMP2L	1	
53	961501	HEX. HD. TAPPING SCREW D5 X 60	2	
* 54	340898	STATOR SENSOR PCB SET 100V-127V	1	TILL 12.2014
* 54	340921	STATOR FET PCB SET 100V-127V	1	SINCE 2.2015
* 54	340899	STATOR SENSOR PCB SET 220V-240V	1	
55	338168	HOUSING	1	
56	333225	DUST SEAL	1	
57	339065	PACKING (B)	2	
58	338170	TAIL COVER	1	
59	998485	HEX. SOCKET HD. BOLT (W/FLANGE) M5 X 14	4	
60	6202DD	BALL BEARING 6202DDCMP2L	1	
61	980700	DUST WASHER (B)	1	
* 62	360992	ROTOR	1	
* 62	361015	ROTOR ASS'Y	1	INCLUD. 51,52,60,61 FOR USA,CAN
* 63	338188	CONTROLLER ASS'Y 100V-127V	1	INCLUD.64-66 TILL 12.2014
* 63	339186	CONTROLLER ASS'Y 100V-127V	1	INCLUD.64-66 SINCE 2.2015
* 63	338189	CONTROLLER ASS'Y 220V-240V	1	INCLUD.64-66
64	339056	RUBBER SHEET (C)	1	
65	339055	RUBBER SHEET (A)	4	
66	339057	RUBBER SHEET (D)	1	
67	338184	PANEL ASS'Y	1	INCLUD.65
68	991690	SEAL LOCK HEX. SOCKET HD. BOLT M5 X 12	2	
69	991711	DISTANCE PIECE (B)	2	
70	338173	HANDLE (A)	1	
* 71	338180	FILTER PCB ASS'Y 100V-127V	1	INCLUD.80
* 71	338181	FILTER PCB ASS'Y 220V-240V	1	INCLUD.80
72	310123	TRANSATORY UNIT	1	
73	310124	HANDLE DAMPER	4	
74	338162	HANDLE DAMPER HOLDER	1	
75	338176	BELLOWS	1	
76	337588	TRIGGER	1	
77	337587	SWITCH	1	
78	338174	HANDLE (B)	1	
79	307028	TAPPING SCREW (W/FLANGE) D4 X 25 (BLACK)	5	
80	339058	FILTER PACKING	1	
81	958308Z	PILLAR TERMINAL (A)	1	
* 82	958049	CORD ARMOR D8.2	1	
* 82	940778	CORD ARMOR D10.7	1	
* 82	331335	CORD ARMOR D11.2	1	
83	960266	CORD CLIP	1	
84	984750	TAPPING SCREW (W/FLANGE) D4 X 16	2	
* 85	321537	CORD	1	(CORD ARMOR D10.7)
* 85	930053	CORD	1	(CORD ARMOR D10.7) FOR SIN (110V), MAL (110V),UAE (110V)
* 85	500469Z	CORD	1	(CORD ARMOR D10.7) FOR SIN (230V), MAL (230V),UAE (230V)
* 85	500453Z	CORD	1	(CORD ARMOR D10.7) FOR USA,CAN,PAN
* 85	500483Z	CORD	1	(CORD ARMOR D11.2) FOR GBR (110V)
* 85	337366	CORD	1	(CORD ARMOR D10.7) FOR GBR (230V)

PARTS

DH 52ME

ITEM NO.	CODE NO.	DESCRIPTION	NO. USED	REMARKS
* 85	500206Z	CORD	1	(CORD ARMOR D10.7) FOR PHI
* 85	500457Z	CORD	1	(CORD ARMOR D10.7) FOR CHN
* 85	500502Z	CORD	1	(CORD ARMOR D10.7) FOR TPE
* 85	500488Z	CORD	1	(CORD ARMOR D8.2) FOR BRA
86	338175	HANDLE SHAFT	1	
87	338164	BACK COVER	1	
88	994192	HEX. SOCKET HD. BOLT (W/FLANGE) M5 X 16	4	
89		NAME PLATE	1	
90	338171	ON LOCK BUTTON	1	
91	338172	ON LOCK SPRING	1	
92	338185	ON LOCK PCB (A) ASS'Y	1	INCLUD.93
93	339059	PACKING (A)	1	
94	330209	SIDE HANDLE	1	
95	337577	WING BOLT	1	
96	949859	ROLL PIN D2 X 8 (10 PCS.)	1	
97	338239	MOUNT	1	
98	949556	NUT M6 (10 PCS.)	1	
99	333227	HANDLE BOLT	1	
100	338238	BAND	1	
101	949859	ROLL PIN D2 X 8 (10 PCS.)	1	
102	939542	RETAINING RING FOR D12 SHAFT (10 PCS.)	1	
103	338224	CRANK SHAFT	1	
104	328869	FEATHER KEY 3 X 3 X 25	1	
105	948227	RETAINING RING FOR D47 HOLE	1	
106	6204DD	BALL BEARING 6204DDCMPS2L	1	
107	338227	O-RING (F)	1	
108	986940	SEAL LOCK HEX. SOCKET HD. BOLT M6 X 45	4	
109	338179	ON LOCK PCB (B)	1	
110	339050	FELT PACKING (D)	1	
111	338237	CRANK COVER	1	
112	338177	HEX. SOCKET HD. BOLT (W/FLANGE) M5 X 18	4	
113	338159	CHANGE LEVER	1	
114	337567	LEVER SPRING	1	
115	959149	STEEL BALL D4.76 (10 PCS.)	1	
116	878885	O-RING (S-18)	1	
117	338236	LEVER SHAFT HOLDER	1	
118	939547	RETAINING RING FOR D20 SHAFT (10 PCS.)	1	
119	338160	O-RING (A)	1	
120	338234	CHANGE PLATE	1	
121	339062	FELT PACKING (C)	1	
122	339061	CAP SCREW	1	
123	995396	VALVE	1	
124	328867	OIL SEAL	2	
125	338223	CRANK CASE	1	
126	338242	SLIP CLUTCH ASS'Y	1	INCLUD.127-138
127	338229	BEVEL PINION	1	
128	944109	FEATHER KEY 3 X 3 X 8	1	
129	338230	COLLAR	1	
130	6202DD	BALL BEARING 6202DDCMPS2L	1	
131	313058	WASHER	1	

PARTS

DH 52ME

ITEM NO.	CODE NO.	DESCRIPTION	NO. USED	REMARKS
132	338231	WASHER (A)	1	
133	318554	GEAR HOLDER	1	
134	313057	NEEDLE PIN D6 X 6	8	
135	329095	SPRING (C)	8	
136	338232	SECOND GEAR	1	
137	338233	SPACER	1	
138	629VVM	BALL BEARING 629VVC2PS2L	1	
139	338225	FIRST GEAR	1	
140	338226	SECOND PINION	1	
141	629VVM	BALL BEARING 629VVC2PS2L	1	
142	944525	BEARING WASHER (C)	1	
143	338240	SEAL PACKING	1	
144	321313	SEAL LOCK HEX. SOCKET HD. BOLT M6 X 22	2	
145	338241	GEAR COVER	1	

STANDARD ACCESSORIES

ITEM NO.	CODE NO.	DESCRIPTION	NO. USED	REMARKS
501	981840	GREASE (A) FOR HAMMER.HAMMER DRILL (30G)	1	
502	339066	CASE (PLASTIC)	1	
503	971786	STOPPER ROD	1	

OPTIONAL ACCESSORIES

DH 52ME

ITEM NO.	CODE NO.	DESCRIPTION	NO. USED	REMARKS
601	308471	GREASE FOR HAMMER.HAMMER DRILL (70G)	1	
602	980927	GREASE FOR HAMMER.HAMMER DRILL (500G)	1	
603	320859	SYRINGE (BLOW-OUT BULB TYPE)	1	
604	318085	SYRINGE (BELLOWS TYPE)	1	
605	313448	DRILL BIT (SDS MAX) D16 X 340	1	
606	313456	DRILL BIT (SDS MAX) D16 X 540	1	
607	313449	DRILL BIT (SDS MAX) D19 X 340	1	
608	313457	DRILL BIT (SDS MAX) D19 X 540	1	
609	313450	DRILL BIT (SDS MAX) D22 X 320	1	
610	313458	DRILL BIT (SDS MAX) D22 X 520	1	
611	313451	DRILL BIT (SDS MAX) D25 X 320	1	
612	313459	DRILL BIT (SDS MAX) D25 X 520	1	
613	313452	DRILL BIT (SDS MAX) D28 X 370	1	
614	313460	DRILL BIT (SDS MAX) D28 X 570	1	
615	313453	DRILL BIT (SDS MAX) D32 X 370	1	
616	313461	DRILL BIT (SDS MAX) D32 X 570	1	
617	313454	DRILL BIT (SDS MAX) D38 X 370	1	
618	313462	DRILL BIT (SDS MAX) D38 X 570	1	
619	313455	DRILL BIT (SDS MAX) D40 X 370	1	
620	313463	DRILL BIT (SDS MAX) D40 X 570	1	
621	944460	TAPER SHANK DRILL BIT D11 X 100	1	
622	944461	TAPER SHANK DRILL BIT D12.3 X 110	1	
623	993038	TAPER SHANK DRILL BIT D12.7 X 110	1	
624	944500	TAPER SHANK DRILL BIT D14.5 X 110	1	
625	944477	COTTER	1	
626	313465	ADAPTER (SDS MAX) FOR SDS PLUS SHANK BIT	1	
627	955994	CORE BIT 25MM	1	
628	955995	CORE BIT 29MM	1	
629	955996	CORE BIT 32MM	1	INCLUD.630
630	955997	GUIDE PLATE (FOR CORE BIT 32MM)	1	
631	955998	CORE BIT 35MM	1	INCLUD.632
632	955999	GUIDE PLATE (FOR CORE BIT 35MM)	1	
633	956000	CORE BIT 38MM	1	INCLUD.634
634	956001	GUIDE PLATE (FOR CORE BIT 38MM)	1	
635	955154	CORE BIT 45MM	1	INCLUD.636
636	955166	GUIDE PLATE (FOR CORE BIT 45MM)	1	
637	955155	CORE BIT 54MM	1	INCLUD.638
638	955167	GUIDE PLATE (FOR CORE BIT 54MM)	1	
639	956002	CORE BIT 64MM	1	INCLUD.640
640	956003	GUIDE PLATE (FOR CORE BIT 64MM)	1	
641	955157	CORE BIT 79MM	1	INCLUD.642
642	955168	GUIDE PLATE (FOR CORE BIT 79MM)	1	
643	956004	CORE BIT 94MM	1	INCLUD.644
644	956005	GUIDE PLATE (FOR CORE BIT 94MM)	1	
645	955159	CORE BIT 105MM	1	INCLUD.646
646	955169	GUIDE PLATE (FOR CORE BIT 105MM)	1	
647	956006	CORE BIT 120MM	1	INCLUD.648
648	956007	GUIDE PLATE (FOR CORE BIT 120MM)	1	
649	956728	CORE BIT 150MM	1	INCLUD.650
650	956743	GUIDE PLATE (FOR CORE BIT 150MM)	1	

