

ACTIVE

EN	Installation and service manual	Kitchen Faucet
DE	Installations- und Serviceanleitung	Küchenmischer
FR	Manuel d'installation et d'entretien	Robinet de cuisine
NL	Installatie- en onderhoudshandleiding	Keukenkraan
IT	Manuale per l'installazione e il servizio di assistenza	Rubinetto cucina
ES	Manual de instalación y servicio	Grifo de cocina
PT	Manual de instalação e de assistência	Misturadora de cozinha
EL	Εγκατάσταση και εγχειρίδιο συντήρησης	Μπαταρία κουζίνας
DA	Installations- og servicevejledning	Køkkenblandingsbatteri
NO	Installasjons- og servicemanual	Kjøkkenkran
SV	Installations- och servicehandbok	Köksblandare
FI	Asennus- ja huolto-ohje	Keittiöhana
LT	Montavimas ir techninė priežiūra	Virtuvinis maišytuvas
LV	Uzstādīšanas un apkopes rokasgrāmata	Virtuves jaucējkrāns
ET	Paigaldus- ja hooldusjuhend	Köögikraan
CS	Montážní a servisní návod	Kuchyňská baterie
PL	Instrukcja montażu i serwisowania	Bateria kuchenna
SK	Návod na inštaláciu a obsluhu	Kuchynský kohútik
SL	Priročnik za namestitvev in servisiranje	Kuhinjska pipa
SR	Priručnik za instalaciju i servisiranje	Kuhinjska slavina
HU	Szerelési és szerviz útmutató	Mosogató csaptelep
HR	Priručnik za instalaciju i servis	Kuhinjska slavina
RO	Manual de instalare și service	Robinet de bucătărie
BG	Ръководство за монтаж и обслужване	Кухненски кран
UK	Посібник зі встановлення та обслуговування	Кухонні змішувачі
RU	Руководство по установке и обслуживанию	Кухонный смеситель
TR	Kurulum ve servis kılavuzu	Mutfak Musluğu
ZH	安装和维修手册	厨房龙头
AR	دليل الخدمة والتركيب	صنبور المطبخ

FRANKE



Swivel spout L shape

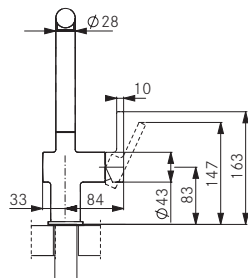
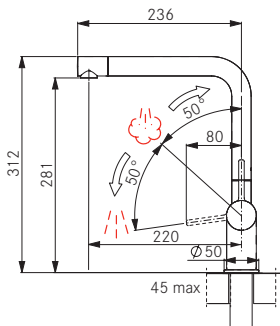
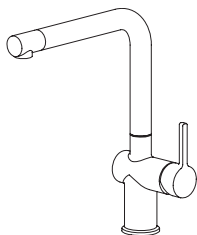

Swivel spout J shape

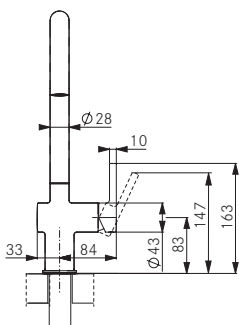
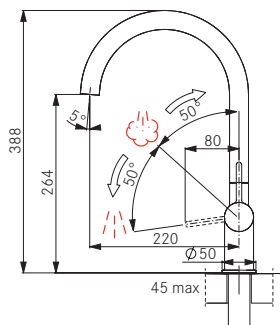
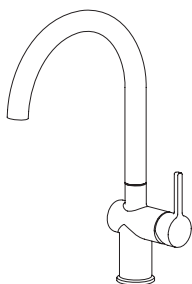

Semi-pro 2 jets

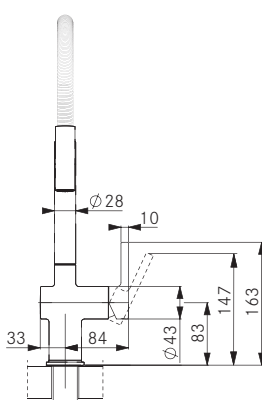
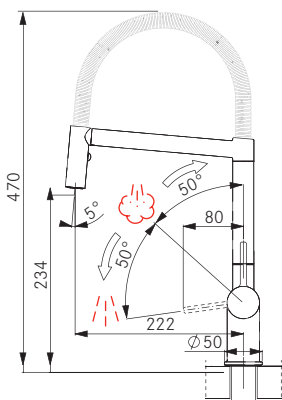
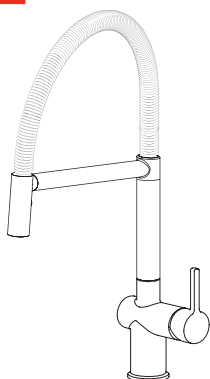

D Pull - out L shape 2 jets

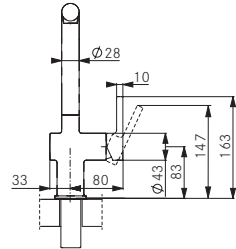
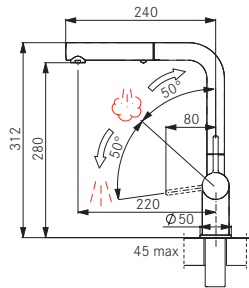
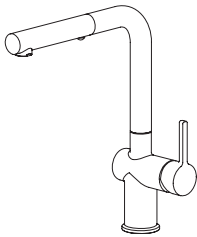

E Pull - down J shape 2 jets

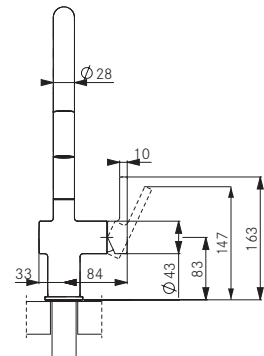
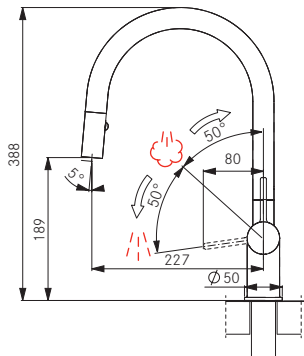
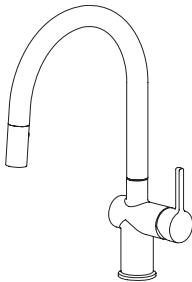

F Window Swivel spout

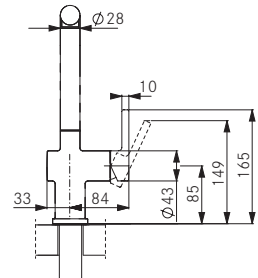
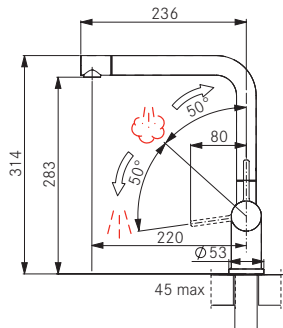
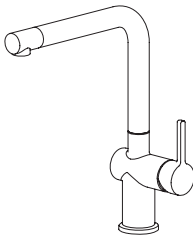

G Window pull-out 2 jets

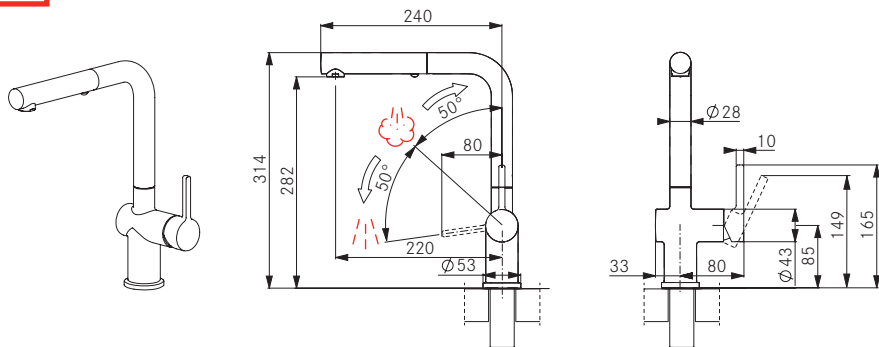

H Window Swivel spout LP

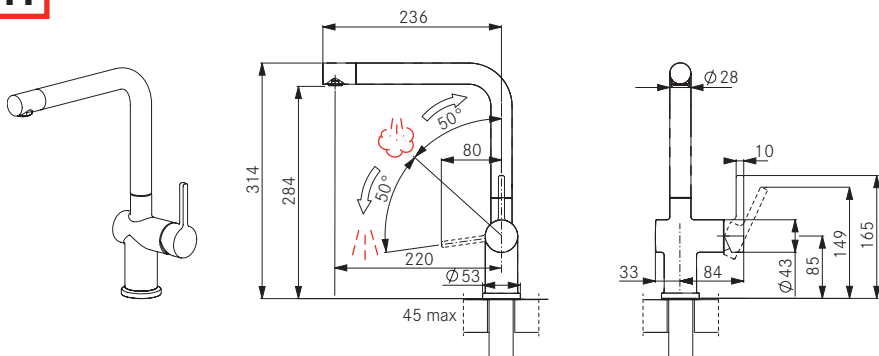

I Window pull-out 1 jet LP

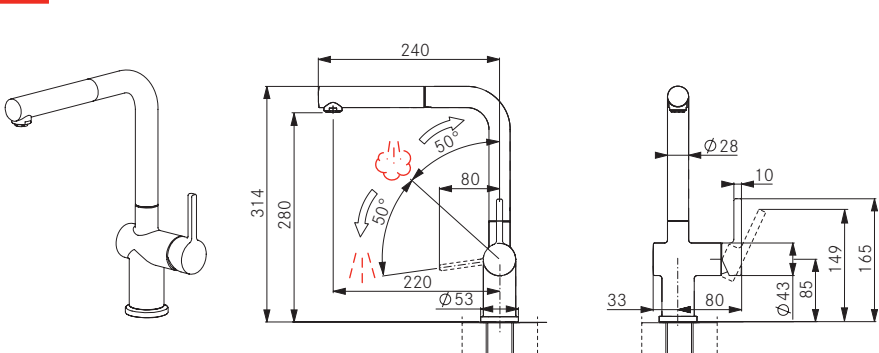

J Pull - out L shape 1 jet

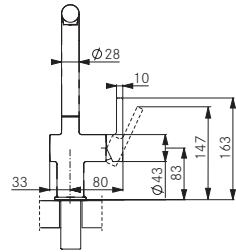
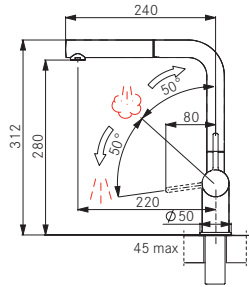
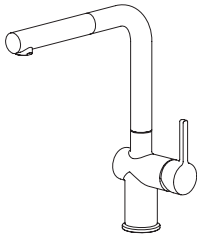

i **1** **C**

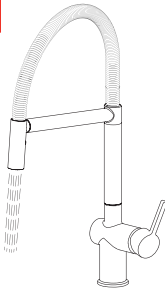

2

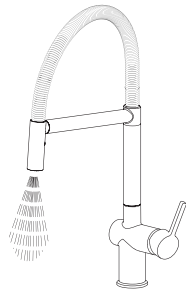
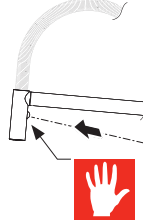

i **1** **D**

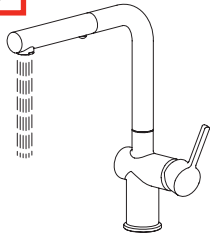

2

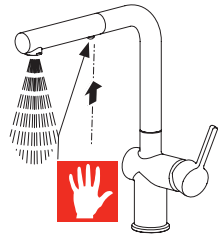

i **1** **E**

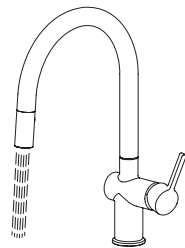

2

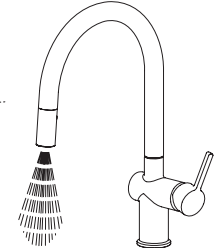
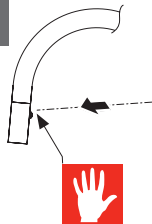

i **1** **G**

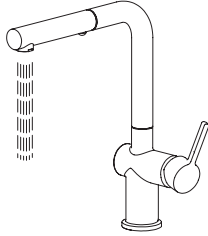

2

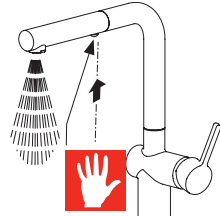

i **F** **H**

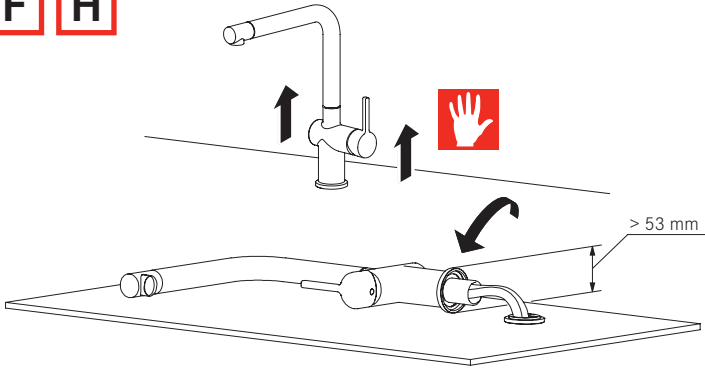

i **G** **I**

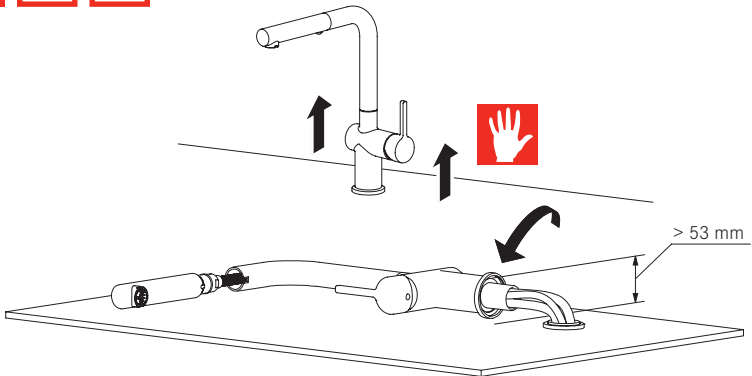

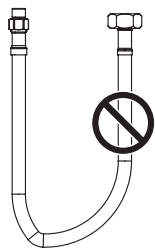

1

A

B

C

F

2

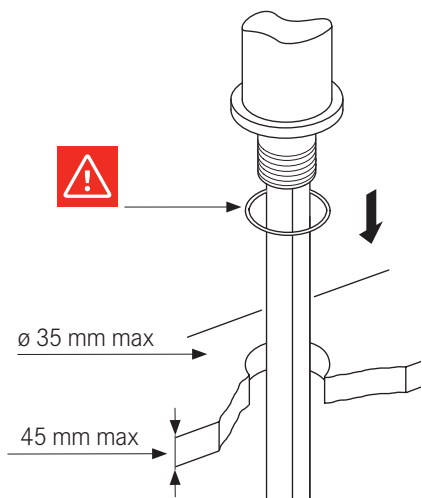

37 mm

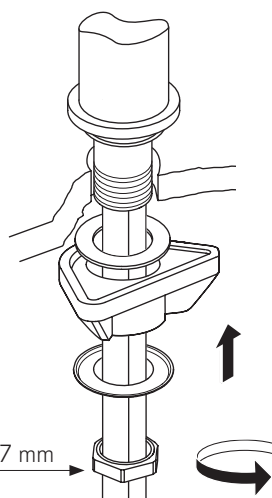



1

H I

2



ø 35 mm max

45 mm max



37 mm

3

H



R max ≥ 50 mm

EU

R max ≥ 50 mm

BOILER

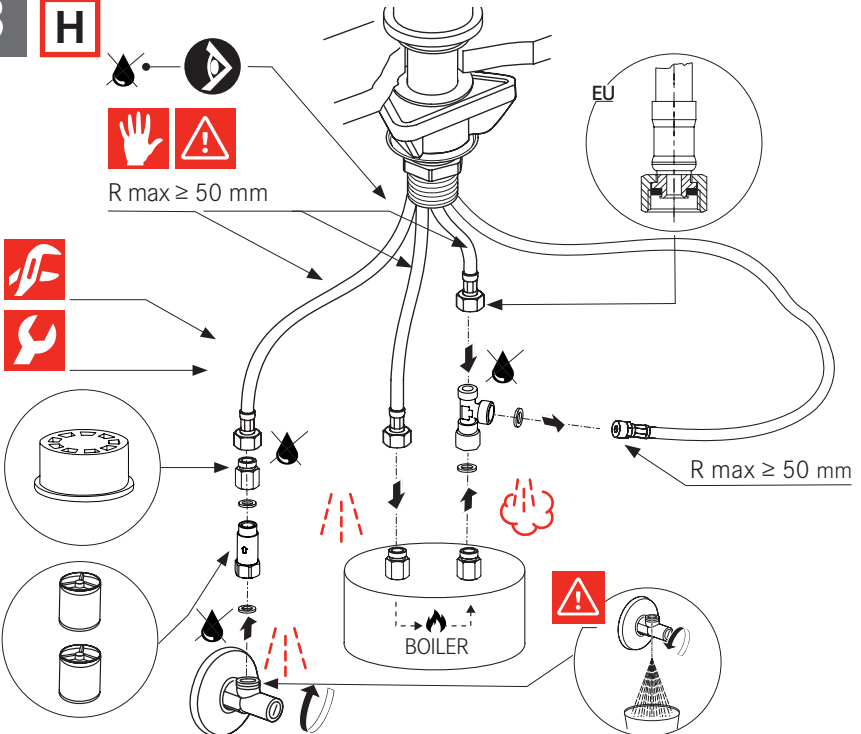

3

I

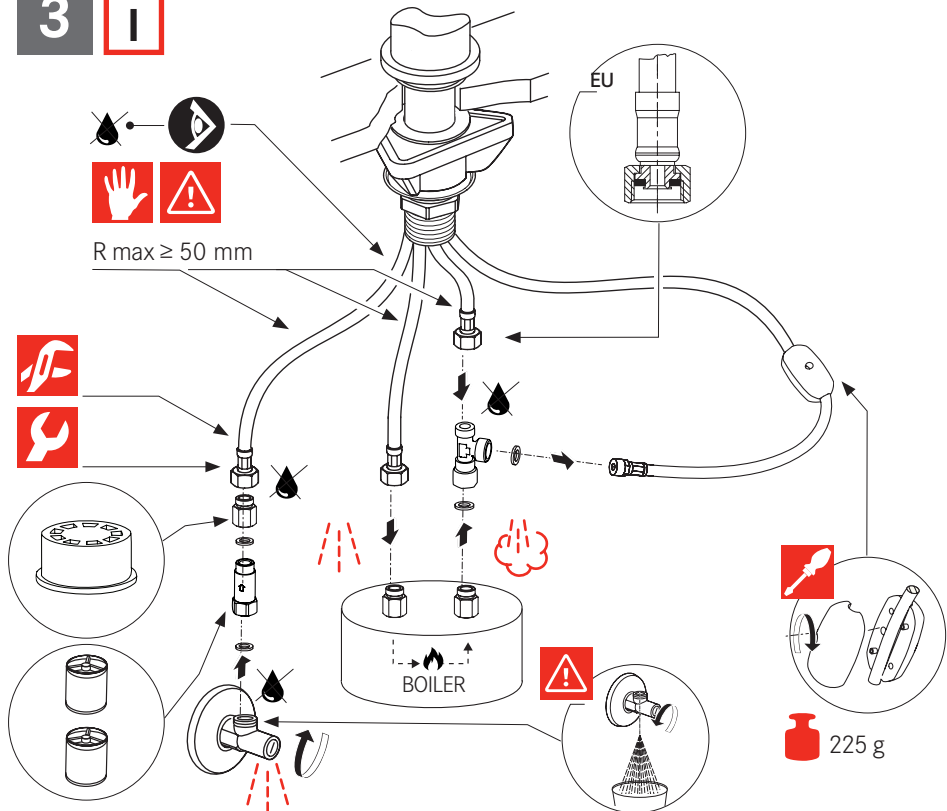

i

A

B

C

D

E

F

G

H

I

J

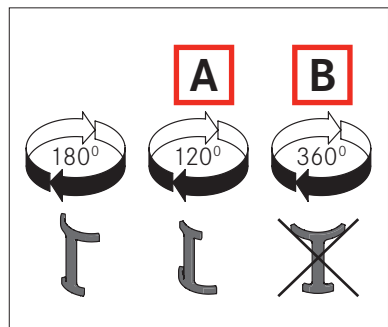
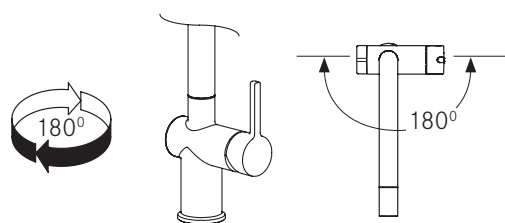



1

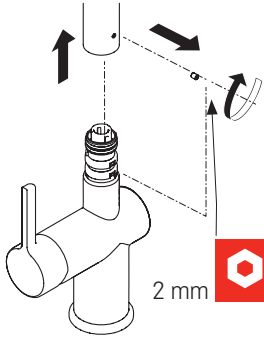

2

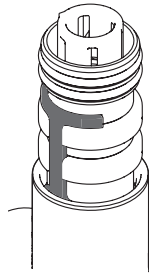

3

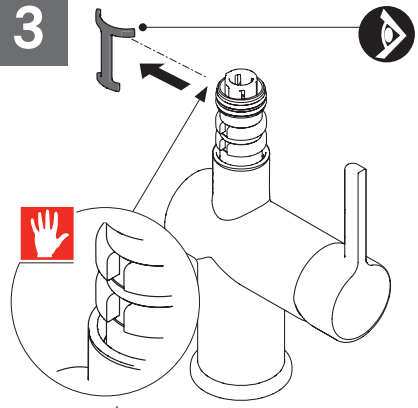

A

4

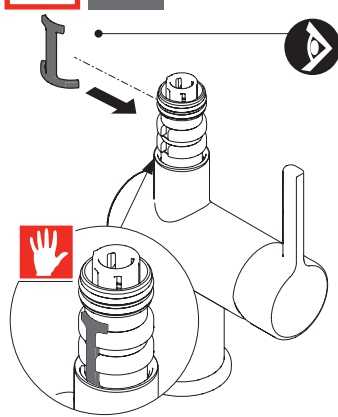

5

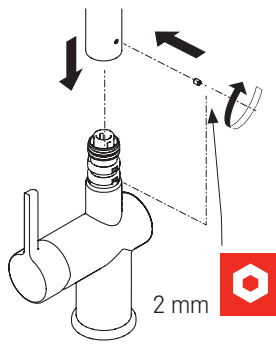

6

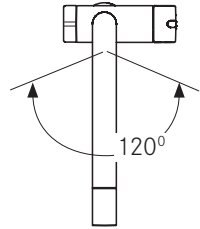

B

4

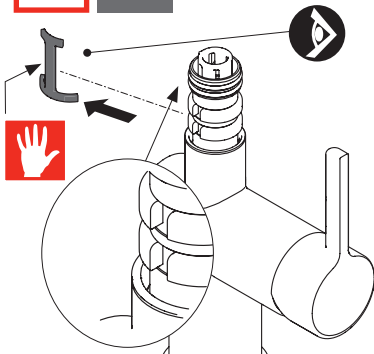

5

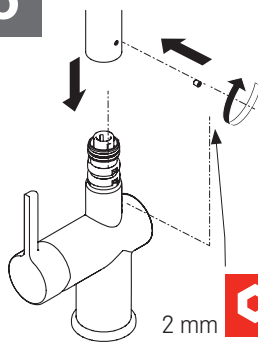

6

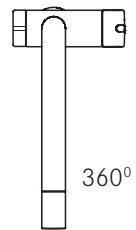



1

A

F

2

A

F

3

A

F

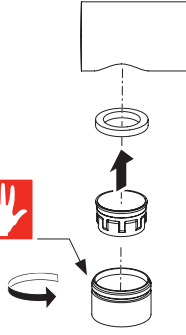
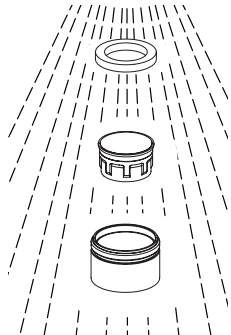
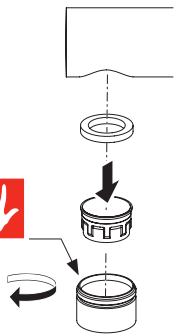

1

B

2

B

3

B

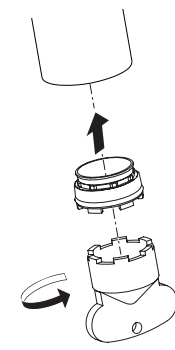
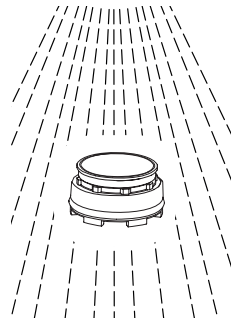
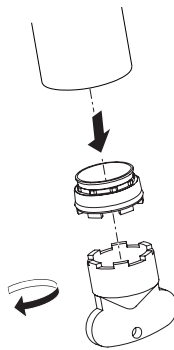

1

D

G

2

D

G

3

D

G

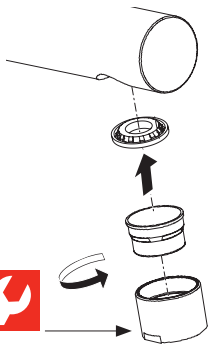
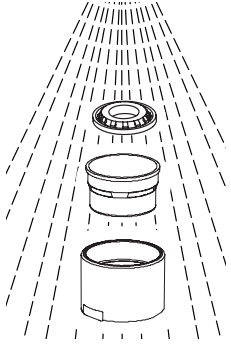
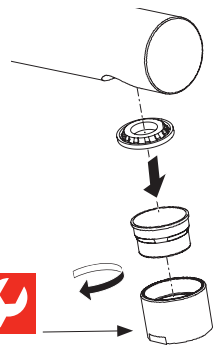

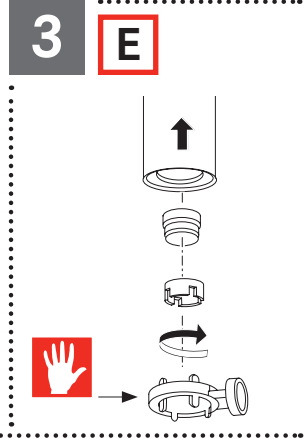
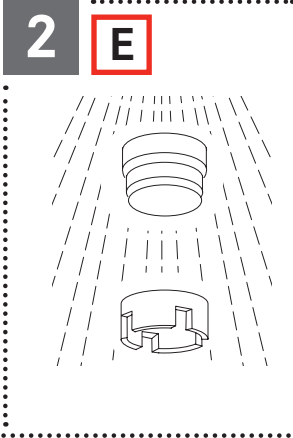
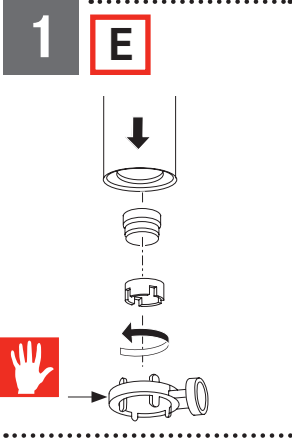
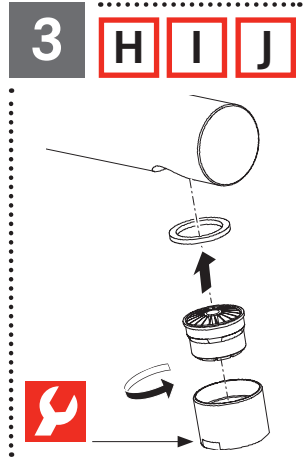
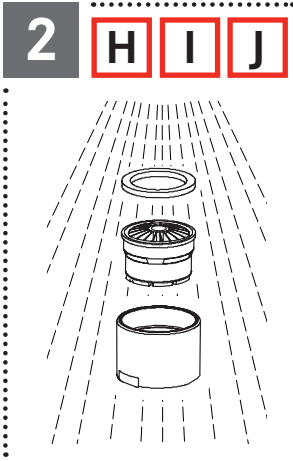
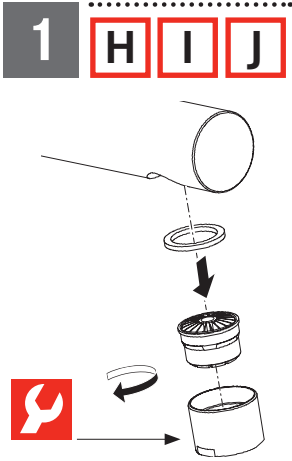
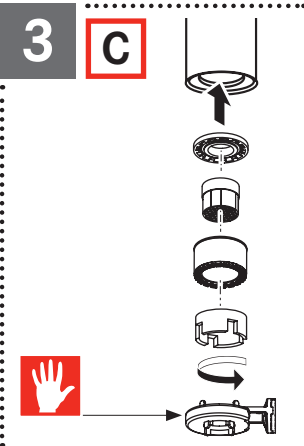
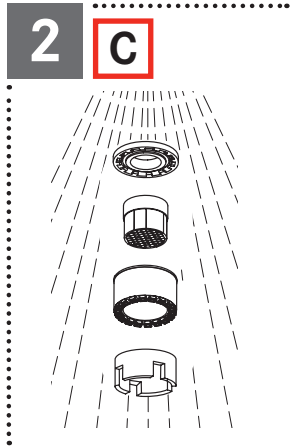
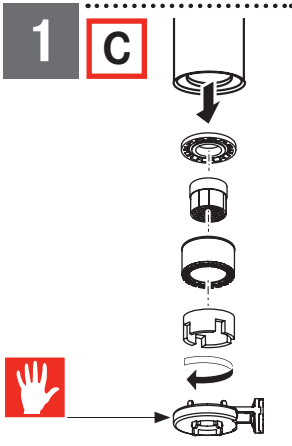

i **C** **D** **E** **G**

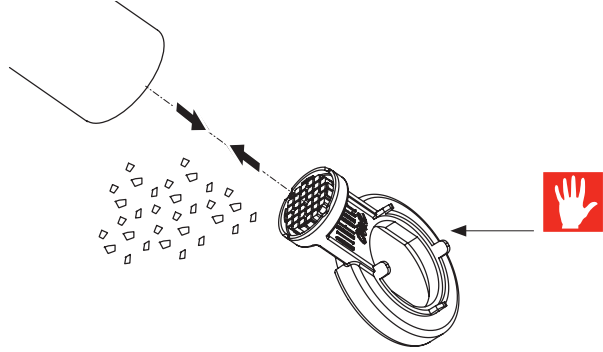

A **B** **C** **D** **E** **F** **G** **H** **I** **J**

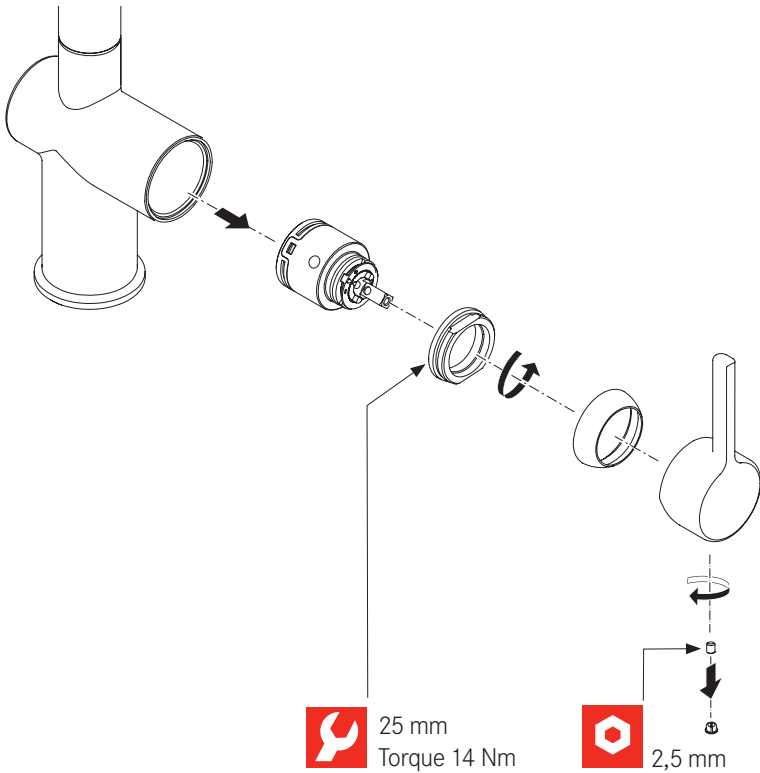

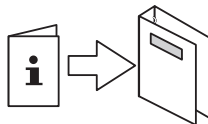
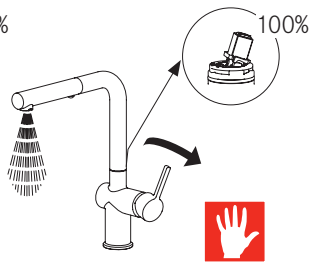
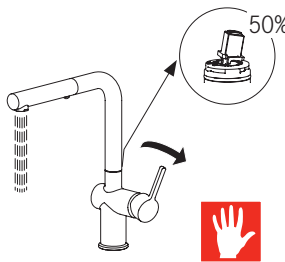
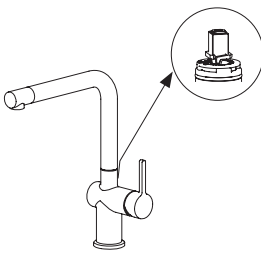
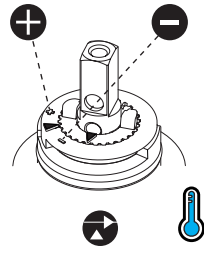
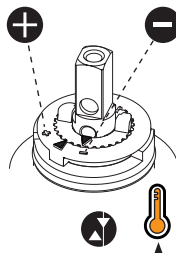
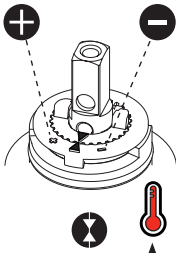
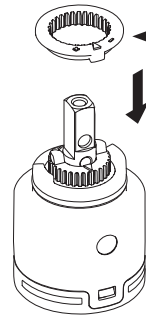
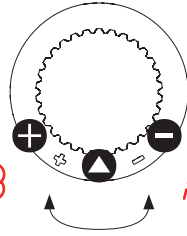
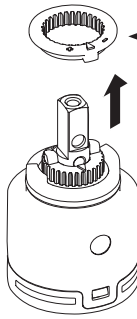

www.franke.com



Periodic checks

- ▶ Check connection and shower hoses periodically for the following:
 - Watertightness
 - Corrosion
 - Mechanical damage
- ▶ Use original spare parts only.
- ▶ Replace damp or dripping hoses.
- ▶ Replace hoses with rusty or oxidized surfaces.
- ▶ Replace hoses that show signs of mechanical damage.

Replacement of the flexibles

- ▶ Don't use a wrench or other items to mount the flexibles on the tap side. Mount these only by hand.



- ▶ Flush all pipes thoroughly before installation.

Operating data	Value		
Operating pressure (ideal)	3 bar	45 PSI	300 kPa
Operating pressure (max.)*	5 bar	70 PSI	500 kPa
Operating pressure (min.)*	1 bar	14.5 PSI	100 kPa
Water temperature (ideal)	60 °C	140 °F	
Water temperature (max.)	70 °C	158 °F	

* Equal pressure is recommended.



Regelmäßige Kontrolle

- ▶ Die Anschluss- und Brausenschläuche periodisch auf folgende Punkte kontrollieren:
 - Dichtheit
 - Korrosionsschäden
 - Mechanische Beschädigung
- ▶ Nur Originalersatzteile verwenden.
- ▶ Feuchte oder tropfende Schläuche ersetzen.
- ▶ Schläuche mit rostiger oder oxidierte Oberfläche ersetzen.
- ▶ Schläuche, die eine mechanische Beschädigung aufweisen, ersetzen.

Austausch der Schläuche

- ▶ Zur Montage der Schläuche am Wasserhahn keine Schlüssel oder andere Werkzeuge verwenden. Nur per Hand montieren.



- ▶ Vor der Montage: Alle Leitungen gründlich spülen.

Betriebsdaten	Wert
Betriebsdruck (ideal)	3 bar
Betriebsdruck (max.)*	5 bar
Betriebsdruck (min.)*	1 bar
Wassertemperatur (ideal)	60 °C
Wassertemperatur (max.)	70 °C

* Druckgleichheit empfehlenswert

FR



Contrôles périodiques

- ▶ Contrôler les flexibles de raccordement et de douche périodiquement sur les points suivants :
 - étanchéité à l'eau
 - corrosion
 - dommage mécanique
- ▶ Utilisez exclusivement des pièces détachées d'origine.
- ▶ Remplacez les flexibles humides ou qui gouttent.
- ▶ Remplacez les flexibles présentant des surfaces rouillées ou oxydées.
- ▶ Remplacez les flexibles qui montrent des signes de dommage mécanique.

Remplacement des tuyaux souples

- ▶ Ne pas utiliser de clé ou d'autre outil pour monter les tuyaux souples côté robinet. Monter les tuyaux souples à la main uniquement.



- ▶ Rincer tous les tuyaux à fond avant l'installation.

Données de fonctionnement	Valeur
Pression de service (idéale)	3 bars
Pression de service (max.)*	5 bars
Pression de service (min.)*	1 bar
Température de l'eau (idéale)	60 °C
Température de l'eau (max.)	70 °C

* Une pression constante est conseillée.



Periodieke controles

- ▶ Controleer regelmatig de aansluit- en doucheslangen op het volgende:
 - Waterdichtheid
 - Corrosie
 - Mechanische schade
- ▶ Gebruik uitsluitend originele onderdelen.
- ▶ Vervang vochtige of druipende slangen.
- ▶ Vervang slangen met roestige of geoxideerde oppervlakken.
- ▶ Vervang slangen die mechanische schade vertonen.

Vervanging van de flexibele slangen

- ▶ Gebruik geen sleutel of andere hulpmiddelen om de slangen aan de kraanzijde te monteren. Monteer ze uitsluitend met de hand.



- ▶ Spoel alle slangen vóór het installeren zorgvuldig door.

Werkingsgegevens	Waarde
Bedrijfsdruk (ideaal)	3 bar
Bedrijfsdruk (max.)*	5 bar
Bedrijfsdruk (min.)*	1 bar
Watertemperatuur (ideaal)	60 °C
Watertemperatuur (max.)	70 °C

* gelijke druk aanbevolen.



Controlli periodici

- ▶ Effettuare periodicamente i seguenti controlli sui flessibili di collegamento e sul flessibile della doccia:
 - Tenuta stagna
 - Corrosione
 - Danni meccanici
- ▶ Utilizzare solo parti di ricambio originali.
- ▶ Sostituire i flessibili che risultano umidi o gocciolano.
- ▶ Sostituire i flessibili che presentano superfici arrugginite o ossidate.
- ▶ Sostituire i flessibili che presentano segni di danni meccanici.

Sostituzione dei raccordi flessibili

- ▶ Non usare chiavi o altri strumenti per montare i raccordi flessibili sul lato del rubinetto. Montarli esclusivamente a mano.



- Far scorrere abbondante acqua in tutti i tubi prima dell'installazione.

Dati di funzionamento	Valore
Pressione di funzionamento (ideale)	3 bar
Pressione di funzionamento (max)*	5 bar
Pressione di funzionamento (min)*	1 bar
Temperatura acqua (ideale)	60 °C
Temperatura acqua (max)	70 °C

* Si consiglia una pressione uniforme.

ES



Comprobaciones periódicas

- En los caños de ducha y los latiguillos de conexión, compruebe periódicamente lo siguiente:
 - Estanqueidad
 - Corrosión
 - Daño mecánico
- Use exclusivamente recambios originales.
- Si los latiguillos o caños están húmedos o gotean, sustitúyalos.
- Si los latiguillos o caños presentan zonas oxidadas o herrumbrosas, sustitúyalos.
- Si los latiguillos o caños presentan signos de daño mecánico, sustitúyalos.

Sustitución de los elementos flexibles

- No utilizar llaves ni otro tipo de herramientas para fijar los elementos flexibles en el lado del grifo. Fijarlos solamente a mano.



- Enjuague a fondo todos los tubos antes de proceder con la instalación.

Datos de funcionamiento	Valor		
Presión de funcionamiento (ideal)	3 bares	45 PSI	300 kPa
Presión de funcionamiento (máx.)*	5 bares	70 PSI	500 kPa
Presión de funcionamiento (mín.)*	1 bar	14,5 PSI	100 kPa
Temperatura del agua (ideal)	60 °C	140 °F	
Temperatura del agua (máx.)	70 °C	158 °F	

* Se recomienda una presión homogénea.



Verificações periódicas

- ▶ Verifique os tubos de ligação e do chuveiro periodicamente quanto ao seguinte:
 - Estanqueidade à água
 - Corrosão
 - Danos mecânicos
- ▶ Utilize apenas peças sobresselentes originais.
- ▶ Substitua os tubos que estejam húmidos ou a pingar.
- ▶ Substitua os tubos com superfícies ferrugentas ou oxidadas.
- ▶ Substitua os tubos que mostrem sinais de danos mecânicos.

Substituição dos flexíveis

- ▶ Não use uma chave de fenda ou outros itens para montar os flexíveis no lado da torneira. Monte usando somente as mãos.



- ▶ Lave bem todos os tubos antes da instalação.

Dados de operação	Valor		
Pressão de operação (ideal)	3 bar	45 PSI	300 kPa
Pressão de operação (máx.)*	5 bar	70 PSI	500 kPa
Pressão de operação (mín.)*	1 bar	14,5 PSI	100 kPa
Temperatura da água (ideal)	60 °C	140 °F	
Temperatura da água (máx.)	70 °C	158 °F	

* É recomendada uma pressão igual.



Περιοδικοί έλεγχοι

- ▶ Ελέγχετε τακτικά τις υδραυλικές συνδέσεις και τον εύκαμπτο σωλήνα του ντους για τα ακόλουθα:
 - Στεγανότητα
 - Διάβρωση
 - Μηχανική βλάβη
- ▶ Χρησιμοποιείτε μόνο αυθεντικά ανταλλακτικά.
- ▶ Αντικαταστήστε σωλήνες με υγρασία ή σταγονίδια.
- ▶ Αντικαταστήστε σωλήνες με σκουριασμένες ή οξειδωμένες επιφάνειες.
- ▶ Αντικαταστήστε σωλήνες που παρουσιάζουν σημάδια μηχανικής βλάβης.

Αντικατάσταση των εύκαμπτων σωλήνων

- ▶ Μην χρησιμοποιείτε γαλλικό κλειδί ή άλλα εργαλεία για την τοποθέτηση των εύκαμπτων σωλήνων στην πλευρά της βρύσης. Τοποθετήστε τους μόνο με το χέρι.



- ▶ Ρίξτε άφθονο νερό στους σωλήνες πριν την εγκατάσταση.

Δεδομένα λειτουργίας	Τιμή		
Πίεση λειτουργίας (ιδανικά)	3 bar	45 PSI	300 kPa
Πίεση λειτουργίας (μέγ.)*	5 bar	70 PSI	500 kPa
Πίεση λειτουργίας (ελάχ.)*	1 bar	14,5 PSI	100 kPa
Θερμοκρασία νερού (ιδανικά)	60 °C	140 °F	
Θερμοκρασία νερού (μέγ.)	70 °C	158 °F	

* Συστήνεται όμοια πίεση.

DA



Periodisk kontrol

- ▶ Undersøg forbindelse og bruseslanger periodisk for følgende:

- Vandtæthed
- Tæring
- Mekanisk skade

- ▶ Brug udelukkende originale reservedele.
- ▶ Udskift fugtige eller dryppende slanger.
- ▶ Udskift slanger med rustbelagte eller oxiderede overflader.
- ▶ Udskift slanger med tegn på mekanisk skade.

Udskiftning af forbindelser

- ▶ Brug ikke en skrueøgle eller andre genstande til at montere forbindelserne på tappesiden. Montér kun disse med hånden.



- ▶ Skyl alle rør grundigt igennem før installation.

Driftsdata	Værdi		
Driftstryk (ideelt)	3 bar	45 PSI	300 kPa
Driftstryk (maks.)*	5 bar	70 PSI	500 kPa
Driftstryk (min.)*	1 bar	14,5 PSI	100 kPa
Vandtemperatur (ideel)	60 °C	140 °F	
Vandtemperatur (maks.)	70 °C	158 °F	

* Ens tryk anbefales.



Jevnlige kontroller

- ▶ Kontroller koblinger og dusjslanger jevnlig for følgende:
 - Vanntetthet
 - Korrosjon
 - Mekanisk skade
- ▶ Bare bruk originale reservedeler.
- ▶ Skift ut fuktige eller dryppende slanger.
- ▶ Skift ut slanger med rustne eller oksiderte overflater.
- ▶ Skift ut slanger som viser tegn på mekanisk skade.

Utskiftning av utstyret

- ▶ Ikke bruk skiftenøkkel eller andre gjenstander for å montere utstyret på tappesiden. Dette skal bare monteres for hånd.



- ▶ Skyll grundig gjennom alle rør før installasjon.

Driftsdata	Verdi		
Driftstrykk (ideelt)	3 bar	45 PSI	300 kPa
Driftstrykk (maks.)*	5 bar	70 PSI	500 kPa
Driftstrykk (min.)*	1 bar	14,5 PSI	100 kPa
Vanntemperatur (ideell)	60 °C	140 °F	
Vanntemperatur (maks.)	70 °C	158 °F	

* Likt trykk anbefales.



Regelbundna kontroller

- ▶ Kontrollera regelbundet anslutningen och duschslangarna med avseende på följande:
 - Vattentäthet
 - Korrosion
 - Mekanisk skada
- ▶ Använd endast originalreservdelar.
- ▶ Byt ut fuktiga eller droppande slangar.
- ▶ Byt ut slangar med rostiga eller oxiderade ytor.
- ▶ Byt ut slangar som visar tecken på mekanisk skada.

Utbyte av flexibla slangar

- ▶ Använd inte en skiftnyckel eller andra föremål för att montera slangar på kranens sida. Montera endast dessa för hand.



- Spola grundligt alla rör före installation.

Driftdata	Värde		
Driftstryck (idealiskt)	3 bar	45 PSI	300 kPa
Driftstryck (max.)*	5 bar	70 PSI	500 kPa
Driftstryck (min.)*	1 bar	14,5 PSI	100 kPa
Vattentemperatur (idealisk)	60 °C	140 °F	
Vattentemperatur (max.)	70 °C	158 °F	

* Lika tryck rekommenderas.

FI



Määraikaistarkastukset

- Tarkasta liitokset ja suihkuletkut säännöllisesti seuraavien seikkojen varalta:
 - Vesitiiviys
 - Korroosio
 - Mekaaniset vauriot
- Käytä vain alkuperäisiä varaosia.
- Vaihda kosteat tai valuvat letkut uusiin.
- Vaihda letkut, joiden pinta on ruosteessa tai hapettunut.
- Vaihda letkut, joissa näkyy mekaanisia vaurioita.

Letkujen vaihtaminen

- Älä käytä jakovainta tai muita vastaavia asentaessasi letkuja hanan sivuun. Asenna ne ainoastaan käsin.



- Huuhtelee kaikki putket huolellisesti ennen asennusta.

Käyttötiedot	Arvo		
Käyttöpaine (sopivin)	3 bar	45 PSI	300 kPa
Käyttöpaine (maksimi)*	5 bar	70 PSI	500 kPa
Käyttöpaine (minimi)*	1 bar	14,5 PSI	100 kPa
Veden lämpötila (sopivin)	60 °C	140 °F	
Veden lämpötila (maksimi)	70 °C	158 °F	

* Tasainen paine on suositeltava.



Reguliarūs patikrinimai

- ▶ Periodiškai patikrinkite, ar jungtys ir dušų žarna neturi šių požymių:
 - Nesandarumas
 - Korozija
 - Mechaniniai pažeidimai
- ▶ Naudokite tik originalias atsargines dalis.
- ▶ Drėgnas ar vandenį leidžiančias žarnas pakeiskite.
- ▶ Pakeiskite žarnas, kurių paviršius surūdijęs arba oksidavęsis.
- ▶ Pakeiskite mechaninių pažeidimų požymius turinčias žarnas.

Žarnelių keitimas

- ▶ Nenaudokite veržliarakčio arba kitų įrankių žarnelėms tvirtinti čiaupo pusėje. Jas tvirtinkite tik rankomis.



- ▶ Prieš montavimą visus vamzdžius gerai praplaukite.

Eksplotaciniai duomenys	Vertė		
Darbinis slėgis (idealus)	3 barai	45 PSI	300 kPa
Darbinis slėgis (maks.)*	5 barai	70 PSI	500 kPa
Darbinis slėgis (maž.)*	1 baras	14,5 PSI	100 kPa
Vandens temperatūra (ideali)	60 °C	140 °F	
Vandens temperatūra (didž.)	70 °C	158 °F	

* Rekomenduojamas vienodas slėgis.



Regulāras pārbaudes

- ▶ Savienojumiem un dušas šļūtenēm regulāri jāpārbauda:
 - ūdensnecaurlaidība
 - korozijas pazīmes
 - mehānisku bojājumu pazīmes
- ▶ Izmantojiet tikai oriģinālās rezerves daļas.
- ▶ Nomainiet mitrās vai pilošās šļūtenes.
- ▶ Nomainiet šļūtenes, ja uz to virsmas redzamas rūsas vai oksidācijas pēdas.
- ▶ Nomainiet šļūtenes, ja tām redzamas mehānisku bojājumu pēdas.

Lokano cauruļu nomaiņa

- ▶ Neizmantojiet uzgriežņu atslēgu vai citus instrumentus, lai lokanās caurules uzstādītu pie krāna. To dariet tikai ar rokām.



- ▶ Pirms uzstādīšanas kārtīgi izskalojiet visas caurules.

Tehniskie dati	Vērtība		
Darbības spiediens (ideālais)	3 bar	45 PSI	300 kPa
Darbības spiediens (maks.)*	5 bar	70 PSI	500 kPa
Darbības spiediens (min.)*	1 bar	14,5 PSI	100 kPa
Ūdens temperatūra (ideālā)	60 °C	140 °F	
Ūdens temperatūra (maks.)	70 °C	158 °F	

* Ieteicams vienmērīgs spiediens.

ET



Periodilised kontrollid

- ▶ Kontrollīge ūhendust ja dušivoolikuid periodiliselst järgneva osas:
 - veetihedus
 - korrosioon
 - mehaanilised kahjustused
- ▶ Kasutage ainult originaalvaruosi.
- ▶ Asendage niisked või tilkuvad voolikud.
- ▶ Asendage roostese või oksüdeerunud pinnaga voolikud.
- ▶ Asendage mehaaniliste kahjustustega voolikud.

Paindosade väljavahetamine

- ▶ Ärge kasutage kraanipoolsete paindosade paigaldamiseks mutrivõtīt ega muid esemeid. Paigaldage need ainult käsitsi.



- ▶ Loputage enne paigaldamist torud korralikult läbi.

Tööandmed	Väärtus		
Töösurve (ideaalne)	3 baari	45 PSI	300 kPa
Töösurve (max)*	5 baari	70 PSI	500 kPa
Töösurve (min)*	1 baar	14,5 PSI	100 kPa
Vee temperatuur (ideaalne)	60 °C	140 F	
Vee temperatuur (max)	70 °C	158 F	

* soovituslik on võrdne surve.



Pravidelné kontroly

- ▶ Pravidelně kontrolujte připojovací hadičky a hadičky spršek:
 - zda jsou vodotěsné
 - zda nejsou zkorodované
 - zda nejsou mechanicky poškozené
- ▶ Používejte pouze originální náhradní díly.
- ▶ Vyměňte vlhké nebo kapající hadičky.
- ▶ Vyměňte hadičky s rezavým nebo zoxidovaným povrchem.
- ▶ Vyměňte hadičky, které vykazují známky mechanického poškození.

Výměna pružných dílů

- ▶ K montáži pružných dílů na stranu kohoutu nepoužívejte klíč ani žádné jiné nářadí. Montáž provádějte ručně.



- ▶ Před montáží důkladně propláchněte všechny trubky.

Provozní údaje	Hodnota		
Provozní tlak (ideální)	3 bar	45 PSI	300 kPa
Provozní tlak (max.)*	5 bar	70 PSI	500 kPa
Provozní tlak (min.)*	1 bar	14,5 PSI	100 kPa
Teplota vody (ideální)	60 °C	140 °F	
Teplota vody (max.)	70 °C	158 °F	

* Doporučuje se vyrovnaný tlak.



Kontrola okresowa

- ▶ Sprawdzać węże przyłączeniowe i węże do wyciąganej wylewki pod kątem:
 - wodoszczelności
 - korozji
 - uszkodzeń mechanicznych
- ▶ Używać wyłącznie oryginalnych części zamiennych.
- ▶ Wymienić nasiąknięte lub nieszczelne węże.
- ▶ Wymienić węże, których powierzchnia jest skorodowana lub utleniona.
- ▶ Wymienić węże, na których widoczne są uszkodzenia mechaniczne.

Wymiana elementów elastycznych

- ▶ Nie używać klucza lub innych narzędzi do montażu elementów elastycznych po stronie kranu. Montować tylko ręcznie.



- ▶ Przed montażem dokładnie przepłukać wszystkie rury.

Dane eksploatacyjne	Wartość
Ciśnienie robocze (optymalne)	3 bary
Ciśnienie robocze (maks.)*	5 barów
Ciśnienie robocze (min.)*	1 bar
Temperatura wody (optymalna)	60 °C
Temperatura wody (maks.)	70 °C

* Wartości ciśnienia powinny być jednakowe.

SK



Pravidelné kontroly

- ▶ Pravidelne preverte spojovacie a sprchovacie hadice vzhľadom na:

- Vodotesnosť
- Koróziu
- Mechanické poškodenie

- ▶ Používajte iba originálne náhradné diely.
- ▶ Vymeňte vlhké alebo netesniace hadice.
- ▶ Vymeňte hadice s hrdzavým alebo zoxidovaným povrchom.
- ▶ Vymeňte hadice, ktoré majú známky mechanického poškodenia.

Výmena hadíc

- ▶ Nepoužívajte kľúč ani iné nástroje na montáž hadíc nastrane kohútika. Namontujte hadice iba ručne.



- ▶ Dôkladne prepláchnite všetky hadice pred inštaláciou.

Prevádzkové údaje	Hodnota		
Prevádzkový tlak (ideálny)	3 bary	45 PSI	300 kPa
Prevádzkový tlak (max.)*	5 barov	70 PSI	500 kPa
Prevádzkový tlak (min.)*	1 bar	14,5 PSI	100 kPa
Teplota vody (ideálna)	60 °C	140 °F	
Teplota vody (max.)	70 °C	158 °F	

* Odporúča sa rovnaký tlak.



Intervalni pregledi

- ▶ Povezavo in cevi tuša preverite glede naslednjega:
 - vodotesnost
 - korozija
 - mehanske poškodbe.
- ▶ Uporabljajte samo originalne rezervne dele.
- ▶ Zamenjajte vlažne cevi oz. cevi, ki puščajo.
- ▶ Zamenjajte cevi z zarjavlimi ali oksidiranimi površinami.
- ▶ Zamenjajte cevi, ki kažejo znake mehanskih poškodb.

Zamenjava gibkih cevi

- ▶ Za namestitev gibkih cevi na armaturo ne uporabljajte ključa ali drugih orodij. Namestite jih izključno z roko.



- ▶ Pred namestitvijo vse cevi temeljito izperite.

Delovni podatki	Vrednost		
Delovni tlak (idealni)	3 bari	45 PSI	300 kPa
Delovni tlak (najv.)*	5 barov	70 PSI	500 kPa
Delovni tlak (najm.)*	1 bar	14,5 PSI	100 kPa
Temperatura vode (idealna)	60 °C	140 °F	
Temperatura vode (najv.)	70 °C	158 °F	

* Priporočen je enakomeren tlak.



Redovne prevere

- ▶ Kod priključka i creva tuša redovno proveravati sledeće:
 - Vodootpornost
 - Korozija
 - Mehaničko oštećenje
- ▶ Koristiti samo originalne rezervne delove.
- ▶ Zameniti creva za paru ili kapanje.
- ▶ Zameniti creva sa zarđalim ili oksidiranim površinama.
- ▶ Zameniti creva na kojima postoje znakovi mehaničkog oštećenja.

Zamena fleksibilnih delova

- ▶ Ne koristite ključ niti druge predmete za montiranje fleksibilnih delova sa strane slavine. Njih montirajte isključivo rukom.



- Temeljno isprati sva creva pre instalacije.

Radni parametri	Vrednost		
Radni pritisak (idealni)	3 bara	45 PSI	300 kPa
Radni pritisak (maks.)*	5 bara	70 PSI	500 kPa
Radni pritisak (min.)*	1 bar	14,5 PSI	100 kPa
Temperatura vode (idealna)	60 °C	140 °F	
Temperatura vode (maks.)	70 °C	158 °F	

* Preporučuje se podjednaki pritisak.

HU



Rendszeres ellenőrzések

- Rendszeresen ellenőrizze a csatlakozót és a zuhanytömlőt a következők tekintetében:
 - vízszivárgás
 - korrózió
 - mechanikus sérülés
- Kizárólag eredeti pótalkatrészeket használjon.
- Cserélje ki a szivárgó vagy csöpögő tömlőket.
- Cserélje ki a rozsdás vagy oxidált felületű tömlőket.
- Cserélje ki a tömlőket, ha mechanikus sérülés van rajtuk.

Flexibilis cső cseréje

- Ne használjon csavarkulcsot vagy egyéb szerszámot a flexibilis cső csapra történő felszereléséhez. Ezeket csak kézzel szerelje fel.



- Szerelés előtt öblítse át alaposan a tömlőket.

Üzemi adatok	Érték		
Üzemi nyomás (ideális)	3 bar	45 psi	300 kPa
Üzemi nyomás (max.)*	5 bar	70 psi	500 kPa
Üzemi nyomás (min.)*	1 bar	14,5 psi	100 kPa
Víz hőmérséklet (ideális)	60 °C	140 °F	
Víz hőmérséklet (max.)	70 °C	158 °F	

* Állandó nyomás biztosítása ajánlott.



Povremene provjere

- ▶ Povremeno provjerite spoj i crijeva za tuševe s obzirom na sljedeće:
 - Vodonepropusnost
 - Korozija
 - Mehanička oštećenja
- ▶ Upotrebljavajte samo originalne rezervne dijelove.
- ▶ Zamijenite crijeva koja su vlažna ili cure.
- ▶ Zamijenite crijeva s hrđavim ili oksidiranim površinama.
- ▶ Zamijenite crijeva koja pokazuju znakove mehaničkog oštećenja.

Zamjena gumenih cijevi

- ▶ Zabranjena je upotreba ključa ili nekih drugih predmeta za postavljanje gumenih cijevi na strani slavine. Postavite ih rukom.



- ▶ Prije instalacije temeljito isperite sve cijevi.

Radni podaci	Vrijednost		
Radni tlak (idealni)	3 bar	45 PSI	300 kPa
Radni tlak (maks.)*	5 bar	70 PSI	500 kPa
Radni tlak (min.)*	1 bar	14,5 PSI	100 kPa
Temperatura vode (idealna)	60 °C	140 °F	
Temperatura vode (maks.)	70 °C	158 °F	

* Preporučuje se jednak tlak.



Verificări periodice

- ▶ Verificați periodic conexiunile și orificiile dușului pentru următoarele:
 - Etanșeitate
 - Coroziune
 - Defecțiuni mecanice
- ▶ Utilizați numai piesele originale de schimb.
- ▶ Înlocuiți furtunurile deteriorate sau care picură.
- ▶ Înlocuiți furtunurile ruginite sau cu suprafața oxidată.
- ▶ Înlocuiți furtunurile care arată semne de deteriorare mecanică.

Înlocuirea componentelor flexibile

- ▶ Nu utilizați o chei fixă sau alte obiecte pentru a monta componentele flexibile pe partea robinetului. Acestea trebuie montate doar manual.



- ▶ Înainte de instalare evacuați complet apa din conducte.

Date de operare	Valoare		
Presiunea de operare (ideală)	3 bari	45 PSI	300 kPa
Presiunea de operare (max.)*	5 bari	70 PSI	500 kPa
Presiunea de operare (min.)*	1 bar	14,5 PSI	100 kPa
Temperatura apei (ideală)	60 °C	140 °F	
Temperatura apei (max.)	70 °C	158 °F	

*Se recomandă presiune constantă.

BG



Периодични проверки

- ▶ Редовно проверявайте свързващите маркучи и маркучите на батерията за следното:
 - Водонепропускливост
 - Корозия
 - Механични повреди
- ▶ Използвайте само оригинални резервни части.
- ▶ Подменяйте влажни или капещи маркучи.
- ▶ Подменяйте маркучи с ръждясали или окислени повърхности.
- ▶ Подменяйте маркучи с признаци за механична повреда.

Смяна на гъвките части

- ▶ Не използвайте гаечен ключ или други елементи за монтиране на гъвките части от страната на крана. Монтирайте ги само на ръка.



- ▶ Продушайте внимателно всички тръби преди монтаж.

Дани за експлоатация	Стойност		
Работно налягане (оптимално)	3 бара	45 PSI	300 kPa
Работно налягане (макс.)*	5 бара	70 PSI	500 kPa
Работно налягане (мин.)*	1 бар	14,5 PSI	100 kPa
Температура на водата (оптимална)	60 °C	140 °F	
Температура на водата (макс.)	70 °C	158 °F	

* Препоръчва се равномерно налягане.



Періодичні перевірки

- ▶ Час від часу слід перевіряти з'єднання та сантехнічні шланги на наявність таких ознак:
 - порушення герметичності
 - корозія
 - механічні пошкодження
- ▶ Використовуйте лише оригінальні запасні частини.
- ▶ Замінійте відсирілі шланги та шланги, що протікають.
- ▶ Замінійте шланги з іржавими поверхнями та поверхнями, що окислилися.
- ▶ Замінійте шланги з ознаками механічних пошкоджень.

Заміна гнучких елементів

- ▶ Не використовуйте гайковий ключ або інші інструменти під час монтажу гнучких елементів на стороні крана. Монтуйте їх тільки вручну.



- ▶ Перед встановленням крана слід ретельно промити всі труби.

Техніко-експлуатаційні дані	Значення		
Робочий тиск (ідеальний)	3 бар	45 фунтів/кв. дюйм	300 кПа
Робочий тиск (макс.)*	5 бар	70 фунтів/кв. дюйм	500 кПа
Робочий тиск (мін.)*	1 бар	14,5 фунта/кв. дюйм	100 кПа
Температура води (ідеальна)	60° C	140° F	
Температура води (макс.)	70° C	158° F	

* Рекомендовано застосовувати однаковий тиск.



Периодические проверки

- ▶ Время от времени следует проверять соединения и сантехнические шланги на наличие следующих признаков:
 - нарушение герметичности
 - коррозия
 - механические повреждения
- ▶ Используйте только оригинальные запасные части.
- ▶ Осуществляйте замену отсыревших или протекающих шлангов.
- ▶ Осуществляйте замену шлангов со ржавыми или окислившимися поверхностями.
- ▶ Осуществляйте замену шлангов с признаками механических повреждений.

Замена гибких трубопроводов

- ▶ Не используйте гаечный ключ или другие инструменты для установки гибких трубопроводов со стороны крана. Устанавливайте их только вручную.



- Перед установкой крана необходимо тщательно промыть все трубы.

Технико-эксплуатационные данные	Значение		
Рабочее давление (идеальное)	3 бар	45 фунтов/кв. дюйм	300 кПа
Рабочее давление (макс.)*	5 бар	70 фунтов/кв. дюйм	500 кПа
Рабочее давление (мин.)*	1 бар	14,5 фунта/кв. дюйм	100 кПа
Температура воды (идеальная)	60° C	140° F	
Температура воды (макс.)	70° C	158° F	

* Рекомендовано применять одинаковое давление.

TR



Periyodik kontroller

- Bağlantı ve dış hortumlarını periyodik olarak aşağıdakiler bakımından kontrol edin:
 - Su geçirmezlik
 - Korozyon
 - Fiziksel hasar
- Sadece orijinal yedek parçaları kullanın.
- Nemli veya su damlatan hortumları değiştirin.
- Yüzeyleri paslı veya oksitlenmiş olan hortumları değiştirin.
- Fiziksel hasar belirtisi gösteren hortumları değiştirin.

Esnek parçaların değişimi

- Musluk tarafına esnek parçaları monte ederken anahtar veya başka bir nesne kullanmayın. Bunları yalnızca elle monte edin.



- Monte etmeden önce tüm boruları iyice yıkayın.

Çalışma verileri	Değer		
Çalışma basıncı (ideal)	3 bar	45 PSI	300 kPa
Çalışma basıncı (maks.)*	5 bar	70 PSI	500 kPa
Çalışma basıncı (min.)*	1 bar	14,5 PSI	100 kPa
Su sıcaklığı (ideal)	60 °C	140°F	
Su sıcaklığı (maks.)	70 °C	158°F	

* Eşit basınç tavsiye edilir.



定期检查

- ▶ 定期检查连接和淋浴软管的以下方面：
 - 不透水性
 - 腐蚀程度
 - 机械损伤
- ▶ 仅使用原厂备件。
- ▶ 更换潮湿或滴水的软管。
- ▶ 更换表面生锈或氧化的软管。
- ▶ 更换有机械损伤迹象的软管。

软管更换

- ▶ 不要使用扳手或者其他工具将软管安装到水龙头一侧。 仅可手工安装。



- ▶ 在安装前彻底冲洗所有管道。

操作数据	值		
操作压力(理想值)	3 bar	45 PSI	300 kPa
操作压力(最大值)*	5 bar	70 PSI	500 kPa
操作压力(最小值)*	1 bar	14.5 PSI	100 kPa
水温(理想值)	60 °C	140°F	
水温(最高值)	70 °C	158°F	

* 建议使用等压。

الفحوصات الدورية

- طيم حوض الاستحمام ووصلاته ابشك لدوري بحثع ان الامور التالية:
- إحكام الربط
- التأكل
- التلف الميكانيكي
- ◀ خدام قطع الغيار الأصلية فقط.
- ◀ استبدال الخراطيم التالفة أو المشققة.
- ◀ خراطيم الصدئة أو الأسط حالمؤكسدة.
- ◀ دال الخراطيم التي يظهر عليها علاتام التلف الميكانيكي.



استبدال الأجزاء المرنة

- ◀ لا تستخدم مفتاح أو أشياء أخرى لتتركيب الأجزاء المرنة بجانب الصنوبر.
- ◀ قم بتركيب هذه الأجزاء باليد فقط.

- ◀ مسح جميع الأنابيب جيداً قبل التركيب.



بيانات التشغيل		القيمة
ضغط التشغيل (المثالي)	٣ بار	٤٥ رطلاً لكل بوصة مربعة
ضغط التشغيل (الحد الأقصى)*	٥ بار	٧٠ رطلاً لكل بوصة مربعة
ضغط التشغيل (الحد الأدنى)*	١ بار	١٤,٥ رطل لكل بوصة المربعة
درجة حرارة الماء (المثالية)	٦٠ درجة سليزيوس	١٤٠ درجة فهرنهايت
درجة حرارة الماء (الحد الأقصى)	٧٠ درجة سليزيوس	١٥٨ درجة فهرنهايت

* ينصح باستخدام الضغط المتعادل.



A

Swivel spout L shape

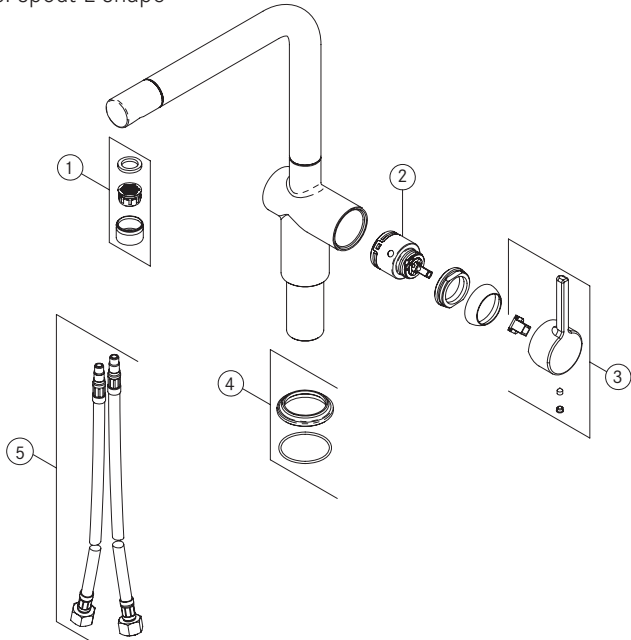

B

Swivel spout J shape

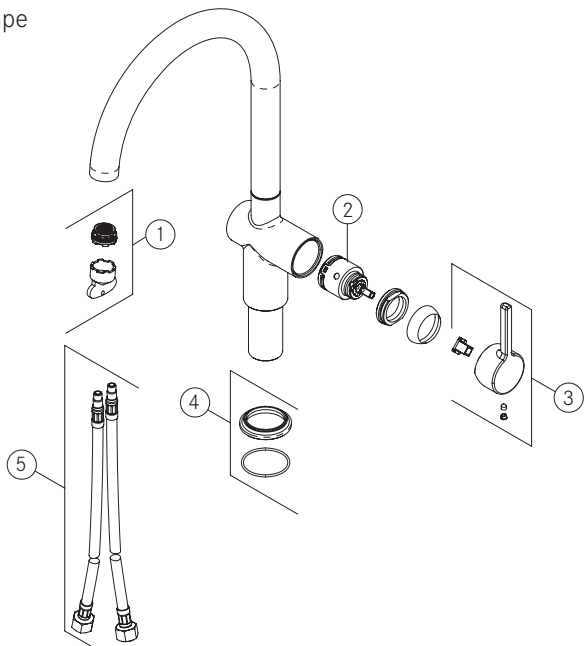



C

Semi-pro 2 jets

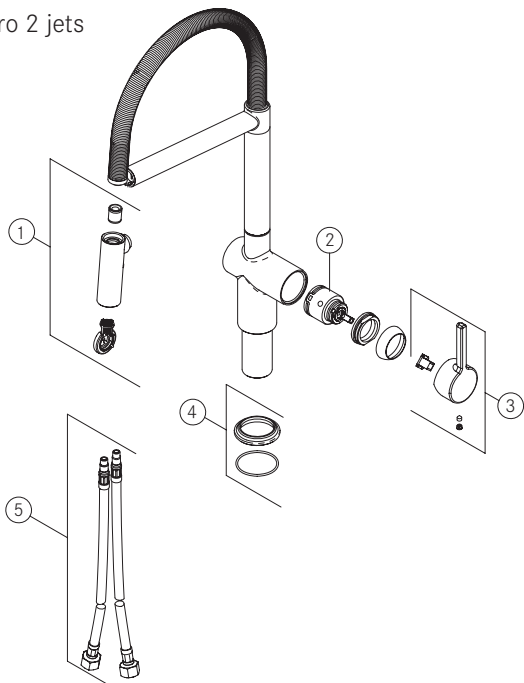

D

Pull-out L shape 2 jets

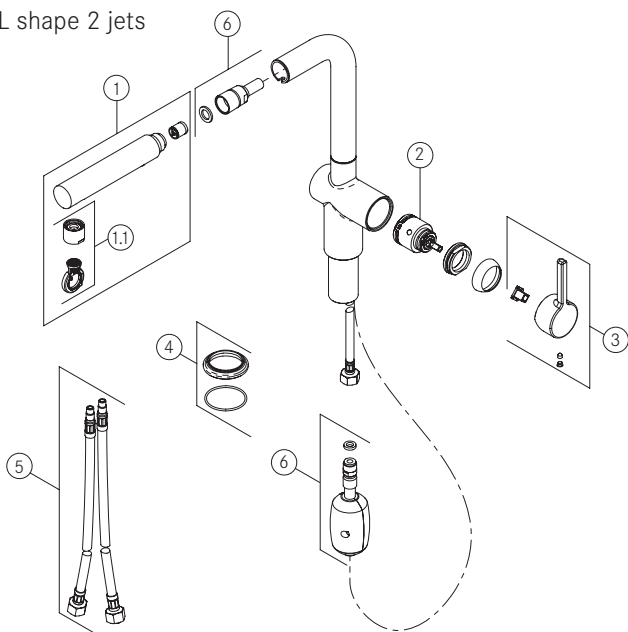



Pull - down J shape 2 jets

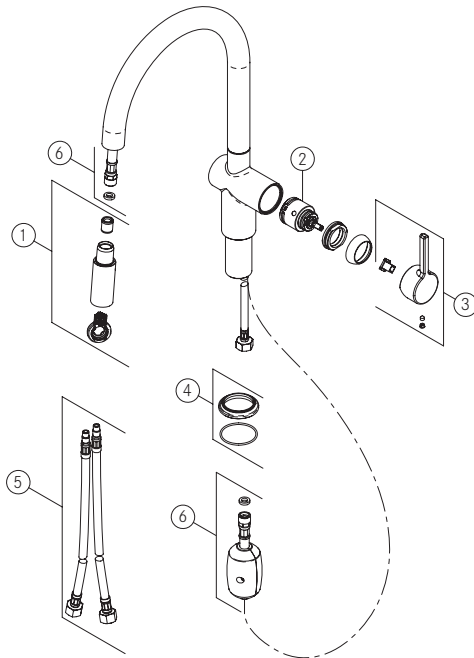

Window Swivel spout

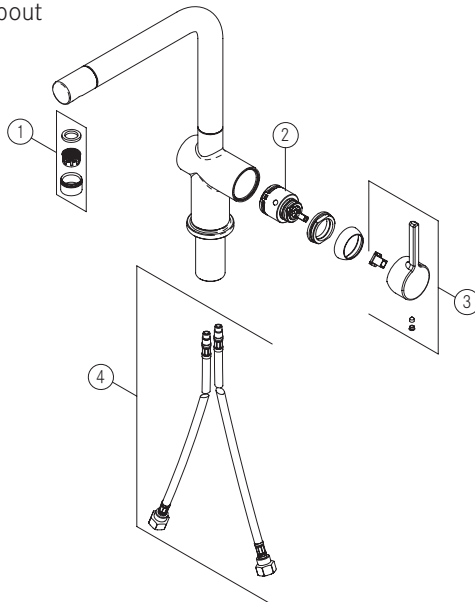



Window pull-out 2 jets

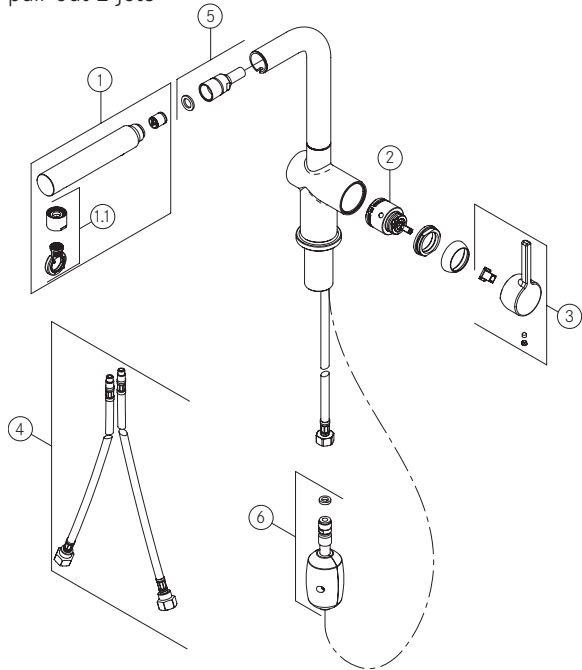

Window Swivel spout LP

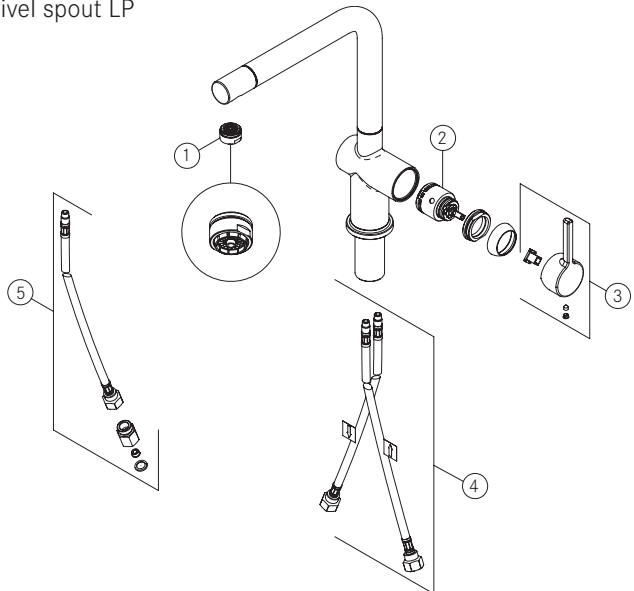



Window pull-out 1 jet LP

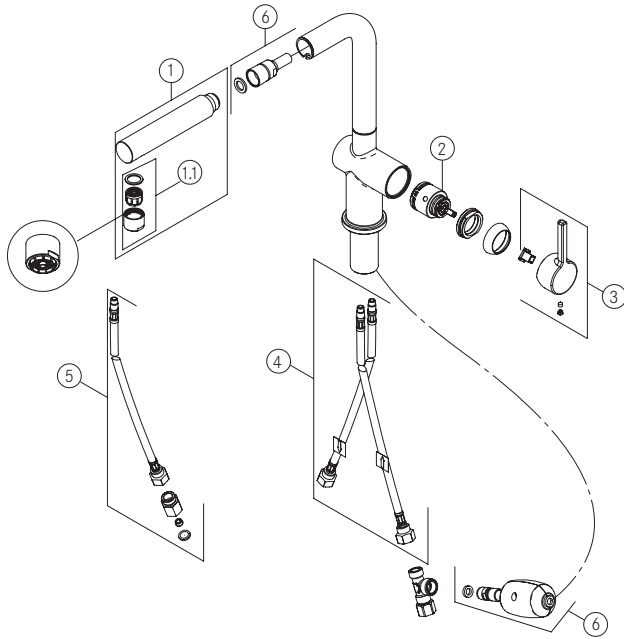

Pull - out L shape 1 jet

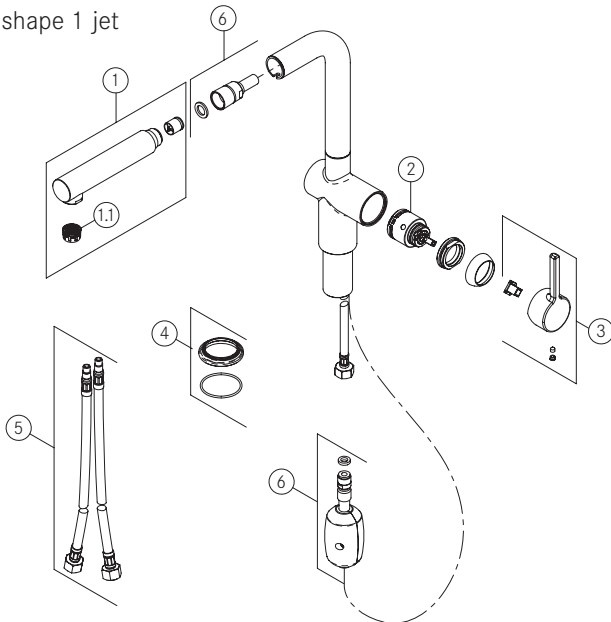

Argentina

Industrias Spar
San Luis S.A.
Buenos Aires 1008
Phone +54 11 4311 7655

Australia

Franke Aus. Pty. Ltd.
(PR Kitchen Systems)
Melbourne 3175
Phone +61 3 9700 9100

Belgium

Franke N.V.
9400 Ninove
Phone +32 54 310 111

Brazil

Franke Sistemas de
Cozinhas do Brasil Ltda.
89219-512 Joinville, SC
Phone +55 47 3431 0501

Canada

Franke Kindred
Canada Ltd.
Midland, ON L4R 4K9
Phone +1 866 687 7465

China

Franke (China) Kitchen
Systems Co., Ltd.
Heshan, Guangdong, 529700
Hotline 400 882 9898

Czech Republic

Franke s.r.o.
190 00 Praha 9
Phone +420 281 090 411

Denmark

Franke KS Denmark
8520 Lystrup
Phone +45 8624 9024

Egypt

Franke Kitchen Systems
Egypt S.A.E.
6th of October City
Hotline 16828

Finland

Franke Finland Oy
76850 Naarajärvi
Phone +358 15 341 11

France

Franke France S.A.S.
60230 Chambly
Phone +33 130 289 400

Germany

Franke GmbH
79713 Bad Säckingen
Phone +49 7761 52 0

Greece

Franke Hellas S.A.
19003 Markopoulo Attikis
(Athens)
Phone +30 22991 500 00

Hong Kong SAR

Franke Asia Hong Kong
Causeway Bay
Phone +852 3184 1900

India

Franke Faber India Pvt Ltd.
Aurangabad - 431 136
Phone 1800 209 3484

Italy

Franke S.p.A.
37019 Peschiera del Garda
Numero Verde 800 359 359

Kazakhstan

Franke Kazakhstan Ltd.
040918 Almaty City
Phone +7 727 297 3812

Morocco

Franke Kitchen System SARL
21 000 Casablanca
Phone +212 522 674 200

Norway

Franke KS Norway
8520 Lystrup, Denmark
Phone +47 35 566 450

Poland

Franke Polska Sp. z o.o.
05-090 Raszyn
Phone +48 22 711 6700

Portugal

Franke Portugal S.A.
2735-531 Cacém
Phone +351 21 426 9670

Romania

Franke Romania SRL
Pantelimon 077145
Phone +40 21 350 1550

Russia

Franke Russia GmbH
199106 St. Petersburg
Phone +7 812 703 1540

Slovak Republic

Franke Slovakia s.r.o.
010 01 Žilina
Phone +421 41 733 6200

South Africa

Franke South Africa
Durban 4052
Phone +27 31 450 6300

Spain

Franke España S.A.U.
08174 Sant Cugat del Vallès
Phone +34 93 565 3535

Sweden

Franke Futurum AB
930 47 Byske
Phone +46 912 405 00

Switzerland

Franke Küchentechnik AG
4663 Aarburg
Phone +41 800 583 243

Thailand

Franke (Thailand) Co., Ltd.
Bangkok 10110
Phone +66 2 013 7900

The Netherlands

Franke Nederland B.V.
5700 AD Helmond
Phone +31 492 585 111

Turkey

Franke Mutfak ve Banyo
Sistemleri Sanayi
ve Ticaret A.S.
41400 Gebze Kocaeli
Phone +90 262 644 6595

Ukraine

Franke Ukraina LLC
02081 Kyiv
Phone +38 044 492 0015

United Arab Emirates

Franke LLC
Ras Al Khaimah
Phone +971 7 203 4700

United Kingdom

Franke UK Ltd.
Manchester M22 5WB
Phone +44 161 436 6280

USA

Franke Kitchen Systems LLC
Smyrna, TN 37167
Phone 800 626 5771



*Make
it
Wonderful*