

ELECTRIC TOOL PARTS LIST

HAMMER Model H 90SG

2014-5-14
(E1)

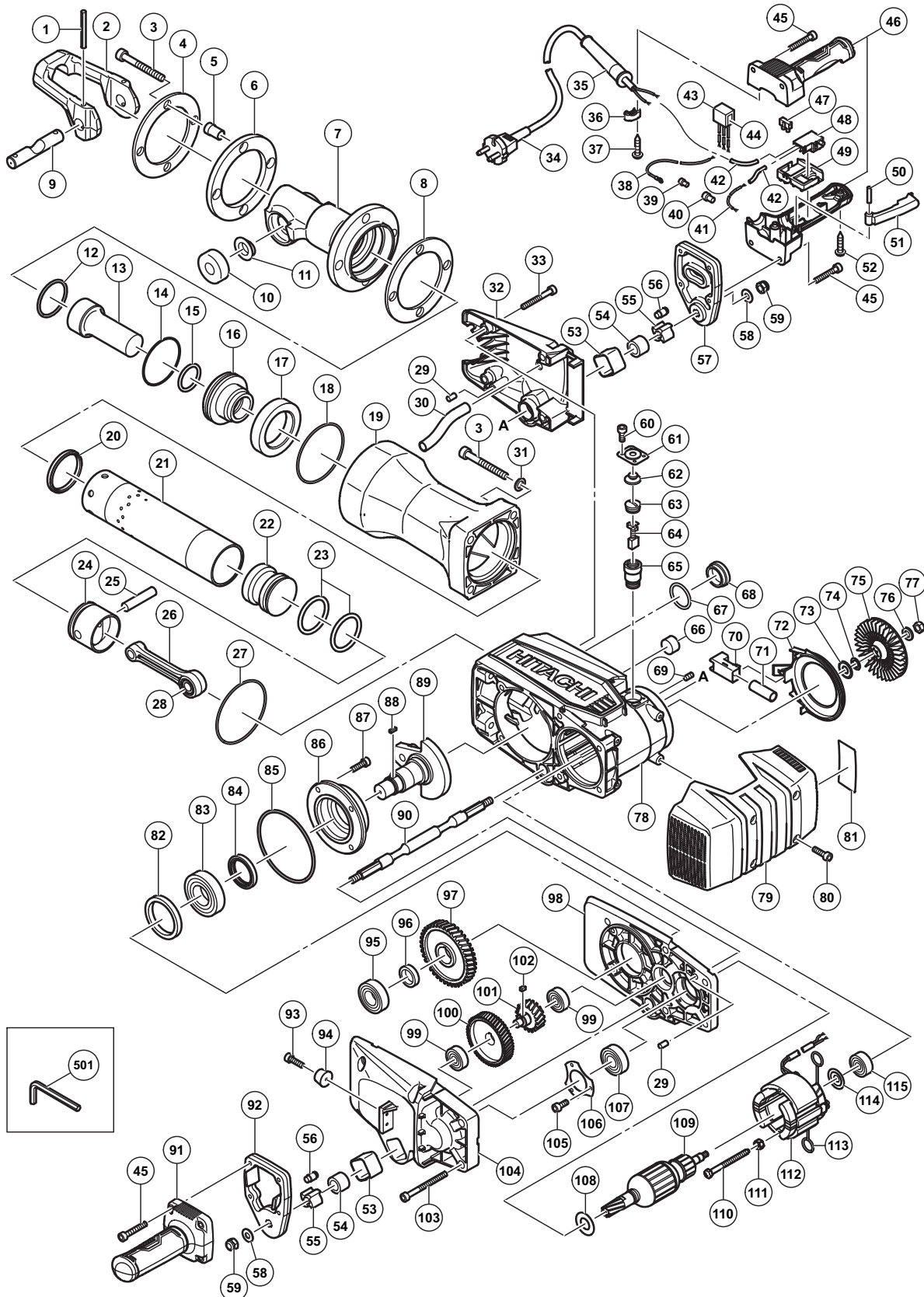

PARTS

H 90SG

ITEM NO.	CODE NO.	DESCRIPTION	NO. USED	REMARKS
1	994416	ROLL PIN D6 X 55	2	
2	337040	RETAINER	1	
3	337028	NYLOCK HIGH TENSION BOLT M12 X 65	8	
4	337037	DAMPER PLATE	1	
5	337036	COLLAR	4	
6	337035	FRONT DAMPER (A)	1	
7	337030	FRONT COVER	1	
8	337034	FRONT DAMPER (B)	1	
9	337041	LEVER PIN	1	
10	337039	RETAINER DAMPER (A)	2	
11	337038	RETAINER DAMPER (B)	2	
12	993188	O-RING	1	
13	337033	SECOND HAMMER	1	
14	992865	O-RING (D)	1	
15	337032	O-RING (A)	1	
16	337031	HAMMER HOLDER	1	
17	992859	DAMPER	1	
18	337029	O-RING (C)	1	
19	337026	CYLINDER CASE	1	
20	337025	CYLINDER DAMPER	1	
21	337023	CYLINDER	1	
22	337024	STRIKER	1	
23	337021	O-RING	2	
24	337020	PISTON	1	
25	337022	PISTON PIN	1	
26	337019	CONNECTING ROD ASS'Y	1	INCLUD.28
27	319685	O-RING	1	
28	956485	NEEDLE BEARING (NSK RLM2220)	1	
29	949480	PIN D8 X 14 (10 PCS.)	2	
30	326541	VINYL TUBE (I.D.9.5 X T0.56 X 85)	1	
31	337027	WASHER D12	4	
32	337012	FAN COVER ASS'Y	1	INCLUD.53
33	985226	SEAL LOCK BOLT M10 X 40	4	
* 34	321537	CORD	1	(CORD ARMOR D10.7)
* 34	337365	CORD	1	(CORD ARMOR D14.2) FOR USA,CAN,MEX,PAN (120V)
* 34	337366	CORD	1	(CORD ARMOR D10.7) FOR SIN,UAE (230V,240V), GBR (230V)
* 34	337367	CORD	1	(CORD ARMOR D10.7) FOR AUS,NZL
* 34	500467Z	CORD	1	(CORD ARMOR D10.7) FOR GBR (110V)
* 34	930053	CORD	1	(CORD ARMOR D10.7) FOR UAE (110V)
* 34	500206Z	CORD	1	(CORD ARMOR D10.7) FOR PHI
* 35	337050	CORD ARMOR D10.7	1	
* 35	337049	CORD ARMOR D14.2	1	
* 36	960266	CORD CLIP	1	
* 36	337053	CORD CLIP	1	FOR USA,CAN,MEX,PAN (120V)
37	956636	TAPPING SCREW (W/WASHER) D4 X 25	2	
* 38	337056	INTERNAL WIRE L350	1	FOR GBR,SAF,EUROPE,NOR, FIN,AUT,TUR,RUS,AUS,NZL
* 39	959140	CONNECTOR 50091 (10 PCS.)	1	FOR GBR,SAF,EUROPE,NOR, FIN,AUT,TUR,RUS,AUS,NZL

PARTS

H 90SG

ITEM NO.	CODE NO.	DESCRIPTION	NO. USED	REMARKS	
* 40	959141	CONNECTOR 50092 (10 PCS.)	1	FOR GBR,SAF,EUROPE,NOR, FIN,AUT,TUR,RUS,AUS,NZL	
* 40	959141	CONNECTOR 50092 (10 PCS.)	2	FOR UAE,IND,PHI,SIN,PAN (220V)	
* 41	337055	INTERNAL WIRE (BLACK)	1	EXCEPT FOR UAE (110V),GBR (110V), USA,CAN,MEX,PAN (120V)	
* 41	337054	INTERNAL WIRE (WHITE)	1	FOR UAE (110V),GBR (110V)	
	42	996438	VINYL TUBE (A) (I.D.7 X T0.5 X 50)	2	
* 43	930153	SUPPORT (B)	1	FOR GBR,SAF,EUROPE,NOR, FIN,AUT,TUR,RUS,AUS,NZL	
* 44	317491	NOISE SUPPRESSOR	1	FOR GBR,SAF,EUROPE,NOR, FIN,AUT,TUR,RUS,AUS,NZL	
	45	993496	SEAL LOCK HEX. SOCKET HD. BOLT M6 X 30	8	
	46	337057	HANDLE (A).(B) SET	1	
* 47	938307	PILLAR TERMINAL	1	FOR GBR,SAF,EUROPE,NOR,FIN,AUT,TUR, RUS,AUS,NZL,USA,CAN,MEX,PAN (120V)	
	48	337051	SWITCH	1	
	49	337052	SUPPORT	1	
	50	337363	PIN D6 X 28	1	
	51	337058	SWITCH LEVER	1	
	52	307028	TAPPING SCREW (W/FLANGE) D4 X 25 (BLACK)	2	
	53	337013	HOLDER (B)	2	
	54	337042	HANDLE DAMPER (B)	2	
	55	337044	HOLDER (A)	2	
	56	337045	HANDLE DAMPER (A)	8	
	57	337046	HANDLE HOLDER (B)	1	
	58	949434	BOLT WASHER M10 (10 PCS.)	2	
	59	337048	LOCK NUT (NYLON INSERT) M10	2	
	60	878356	SEAL LOCK HEX. SOCKET HD. BOLT M4 X 10	4	
	61	337017	CAP COVER	2	
	62	992894	CAP RUBBER	2	
	63	937949	BRUSH CAP	2	
	64	999086	CARBON BRUSH (AUTO STOP TYPE) (1 PAIR)	2	
	65	305597	BRUSH HOLDER	2	
	66	336997	FELT PACKING	1	
	67	980717	O-RING (S-38)	1	
	68	990945	OIL CAP ASS'Y	1	INCLUD.67
	69	938477	HEX. SOCKET SET SCREW M5 X 8	2	
	70	336999	SLEEVE	1	
	71	336998	VINYL TUBE	1	
	72	337010	FAN GUIDE	1	
	73	337387	DUST WASHER (FW)	1	
	74	337386	RUBBER WASHER (FW)	1	
	75	337011	FAN	1	
	76	323212	BOLT WASHER M8 (BLACK)	1	
	77	949558	NUT M8 (10 PCS.)	1	
	78	336996	HOUSING ASS'Y	1	INCLUD.65,69
	79	337018	HOUSING COVER	1	
	80	990935	SEAL LOCK HEX. SOCKET HD. BOLT M6 X 16	4	
	81		NAME PLATE	1	
	82	337003	DISTANCE RING (C)	1	

