



BOSCH

KOSIARKA DO TRAWY

AdvancedRotak 36-850 | 3 600 HB9 802

Spis treści

Rysunek złożeniowy..... 2

Rysunek złożeniowy - E

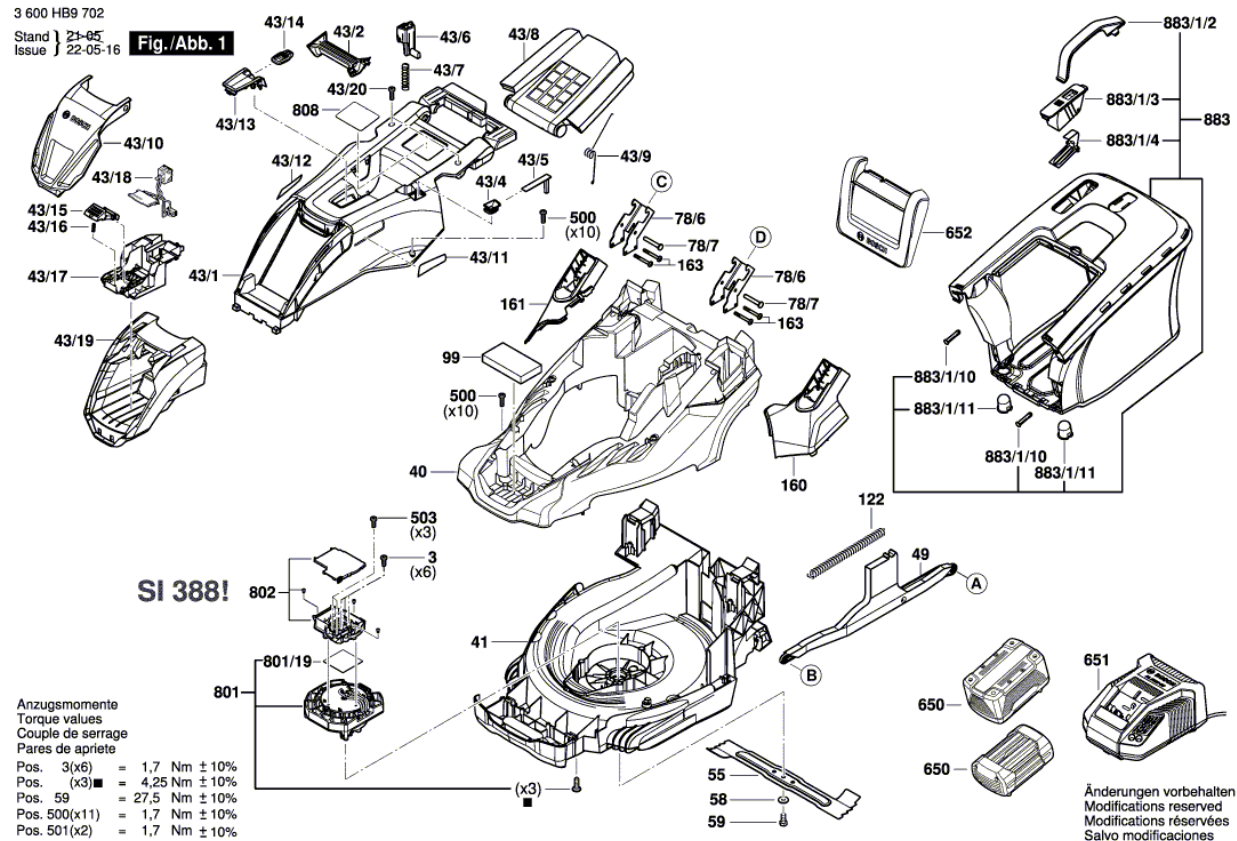

Rysunek złożeniowy - E

3 600 HB9 702

Stand | 21-05-10
Issue | 21-06-01 **Fig./Abb. 2**

