



PARCEL BOX

EN ASSEMBLY INSTRUCTIONS FR INSTRUCTIONS DE MONTAGE GE MONTAGEANLEITUNG NL MONTAGEVOORSCHRIFT
ES INSTRUCCIONES DE MONTAJE IT ISTRUZIONI DI MONTAGGIO PT INSTRUÇÕES DE MONTAGEM



Made in Israel by | Fabriqué en Israël par | Fabricado en Israel por | Hergestellt in Israel von |
Gemaakt in Israël door | Realizzato in Israele da | Fabricado em Israel por
Keter Plastic Ltd., 2 Sapir St. Industrial Area, Herzliya 46852, Israel

5000136

- EN IMPORTANT: Please contact Customer Service if you have any problems or discover any missing parts.
- FR IMPORTANT: Veuillez contacter notre Service Clientèle pour tout problème ou pièce manquante.
- GE WICHTIG: Bitte wenden Sie sich an unseren Kundenservice, falls Sie irgendwelche Probleme haben oder feststellen, daß Teile fehlen.
- ES IMPORTANTE: Sírvase contactar con nuestro Servicio al Cliente por cualquier problema, o pieza que pudiera faltar.
- IT IMPORTANTE: Si prega di contattare il Servizio Clienti per eventuali necessità.
- NL BELANGRIJK: Neemt u in geval van problemen of missende onderdelen a.u.b. contact op met de klantenservice.
- PT IMPORTANTE: favor entrar em contato com o Serviço ao Cliente se houver problemas ou se faltar peças.



USA & Canada:

1-(888)-374-4262

UK: Tel: 0121-5060008

Fax: 0121-4220808

Other European Countries:











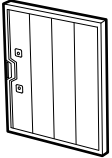

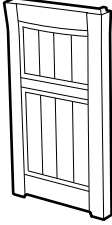
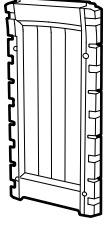

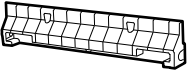
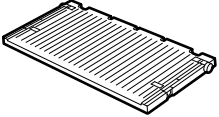
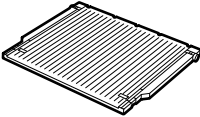
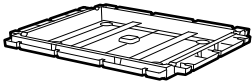
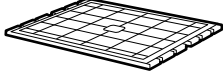
Tel: +31-1612-28301

Fax: +31-1612-28322

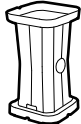
WWW.KETER.COM

EN ASSEMBLY PARTS FR PIÈCES À ASSEMBLER GE MONTAGETEILE NL MONTAGESTUKKEN ES PIEZAS DE ENSAMBLE
IT PARTI DA MONTARE PT PEÇAS DE MONTAGE

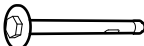
EN Please check all parts and components to ensure that there are no damages or missing items BEFORE starting the construction of the product FR Assurez-vous que les parties et les éléments ne sont pas endommagés et qu'aucun ne manque AVANT de commencer le montage de ce produit GE Bitte überprüfen Sie alle Einzelteile und jegliches Zubehör, um sicherzugehen, dass keine Teile beschädigt sind oder fehlen, BEVOR Sie mit der Montage des Produkts beginnen NL Controleer alle onderdelen en componenten om te verzekeren dat er geen schade of ontbrekende items zijn VOOR dat u het product in elkaar begint te zetten ES ANTES de comenzar la construcción del producto, compruebe todas las partes y componentes para asegurarse de que no hay daños y de que no falta ningún elemento IT Si prega di controllare tutti i pezzi ed i componenti per accertarsi che non ci siano danni o elementi mancanti PRIMA di montare il prodotto PT Por favor, verifique todas as peças e componentes para garantir que não há danos ou itens incompletos ANTES de iniciar a construção do produto

				
PBD (X1)	PBF (X1)	PBB (X1)	PBS (X2)	PBC (X1)
				
BSS (X1)	PSS (X1)	PSL (X1)	FLD (X1)	PFT (X1)
				
PMH (X1)	PML (X2)	PCC (X4)	FLC (X1)	
				
		PP (X19)	HS (X2)	
MTC (X4)				
		JS (X4)	S14 (X14)	

JS(x4) Screws attached are for use on cement surface | JS(x4) Les vis attachées sont destinées à être utilisées sur une surface en ciment | JS(x4) Die beigefügten Schrauben sind für Zementoberflächen | JS(x4) Bijgevoegde schroeven zijn voor gebruik op cementoppervlak | JS(x4) Los tornillos que se incluyen son para usarse en una superficie de cemento | JS(x4) Le viti fissate sono da utilizzare su una superficie di cemento | JS(x4) Os parafusos inclusos são para utilização em superfícies de cimento

It is recommended to secure the box to a cement or wood surface | Il est recommandé de fixer le boîtier sur une surface en ciment ou en bois | Es wird empfohlen, die Box mit einer Zement- oder Holzoberfläche zu verschrauben | Het wordt aanbevolen om de box op een cement- of houtoppervlak te bevestigen | Se recomienda fijar la caja a una superficie de cemento o madera | Si consiglia di fissare la scatola a una superficie di cemento o legno | Recomenda-se fixar a caixa em uma superfície de cimento ou madeira

REQUIRED TOOLS | OUTILS EXIGÉS | HERRAMIENTAS NECESARIAS | BENÖTIGTE WERKZEUGE | BENODIGD GEREEDSCHAP | ATTREZZATURA OCCORRENTE | FERRAMENTAS NECESSÁRIAS

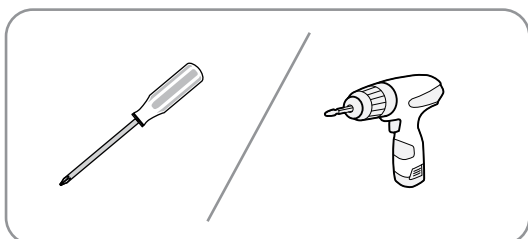

1



PBD (X1)



S14 (X7)

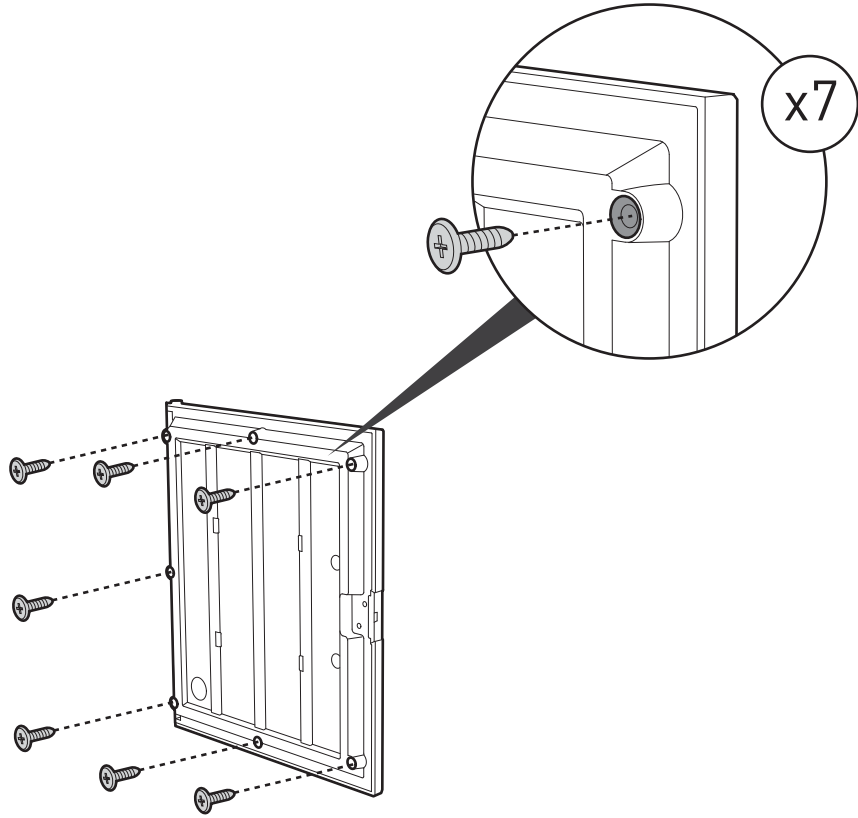

2



PMH (X1)



HS (X2)

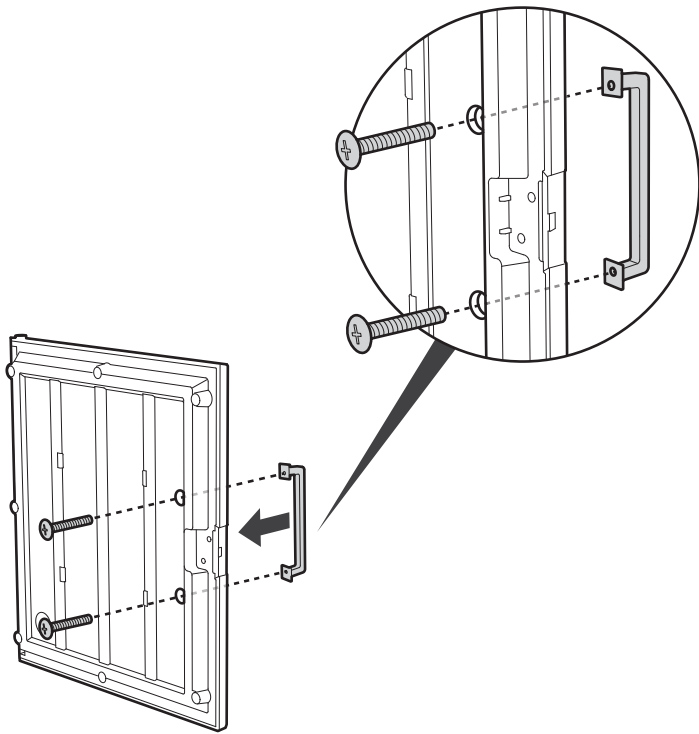

3



PML (X1)



S14 (X2)

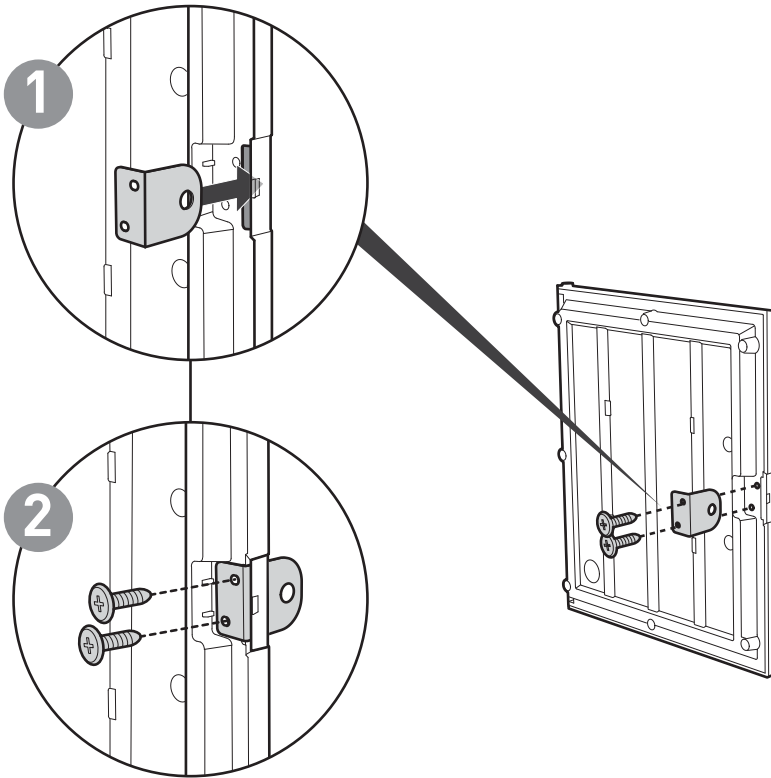

4



PBF (X1)



PML (X1)



S14 (X2)

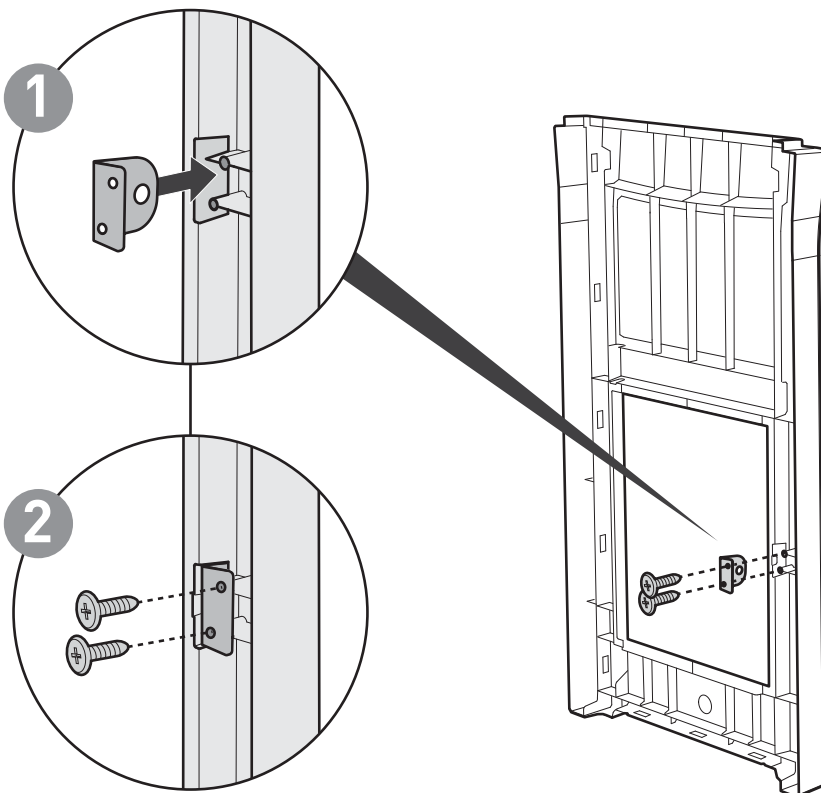

5



PBF+PML



PBD+PMH+PML

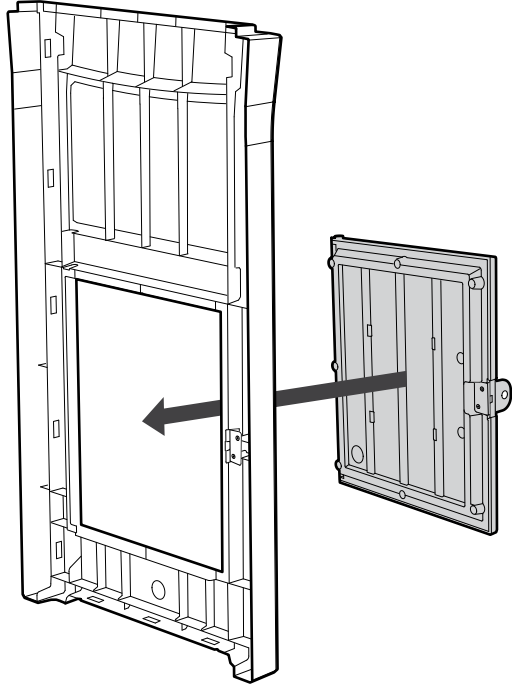

6



PP (X2)

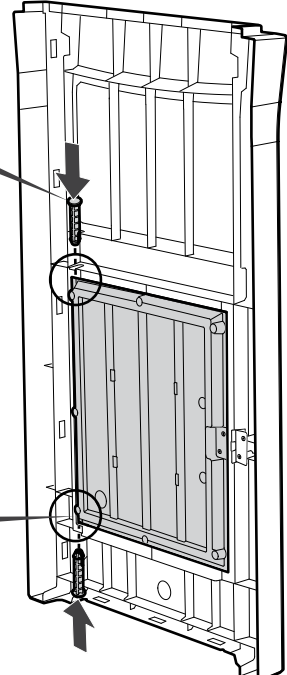
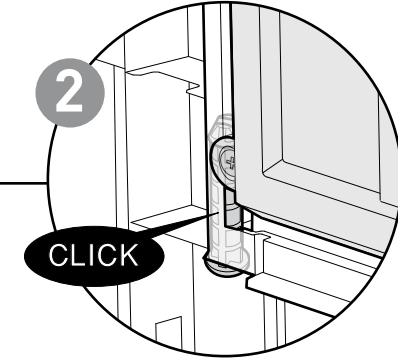
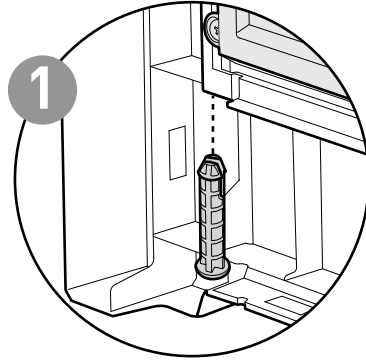
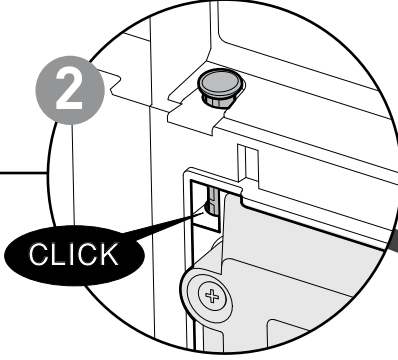
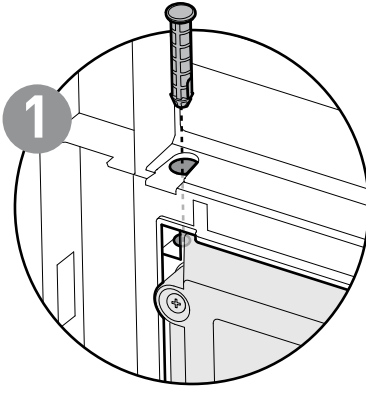

7

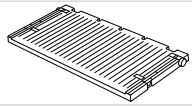

PSS (X1)



MTC (X2)



PP (X2)

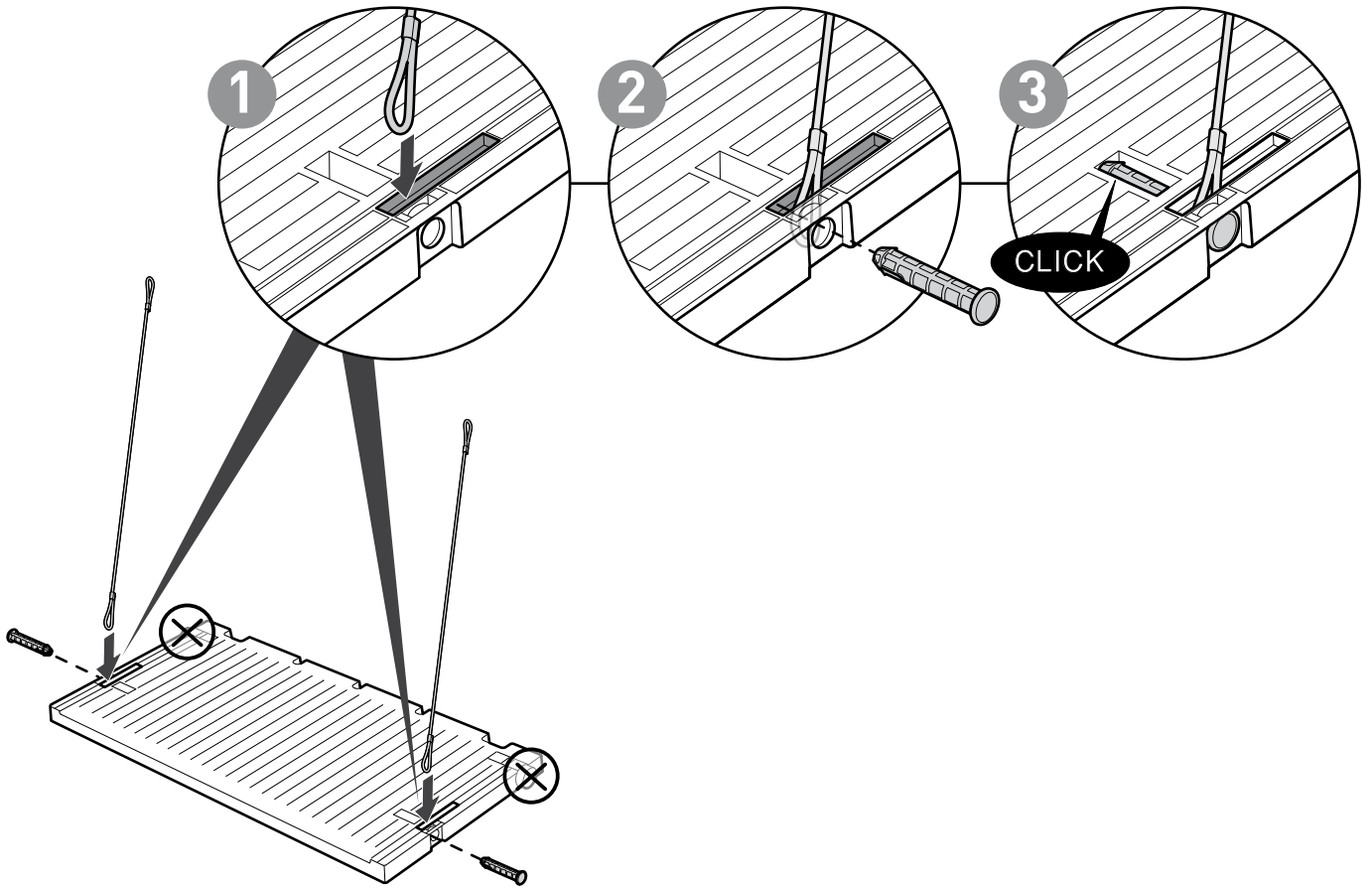

8

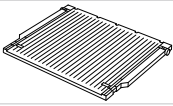

PSL (X1)



MTC (X2)



PP (X2)

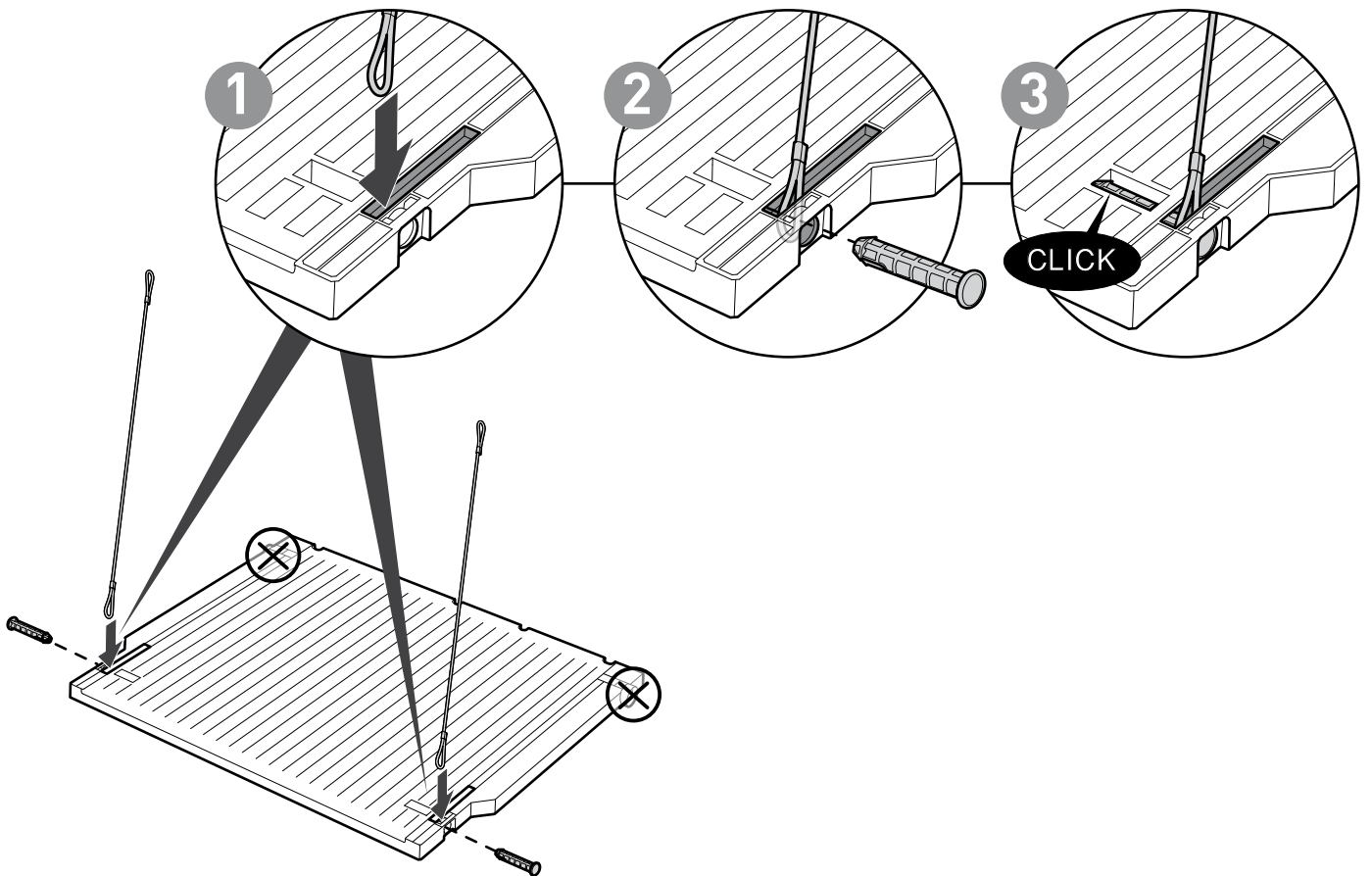

9



PBS (X2)

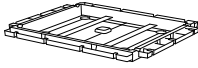

FLD (X1)

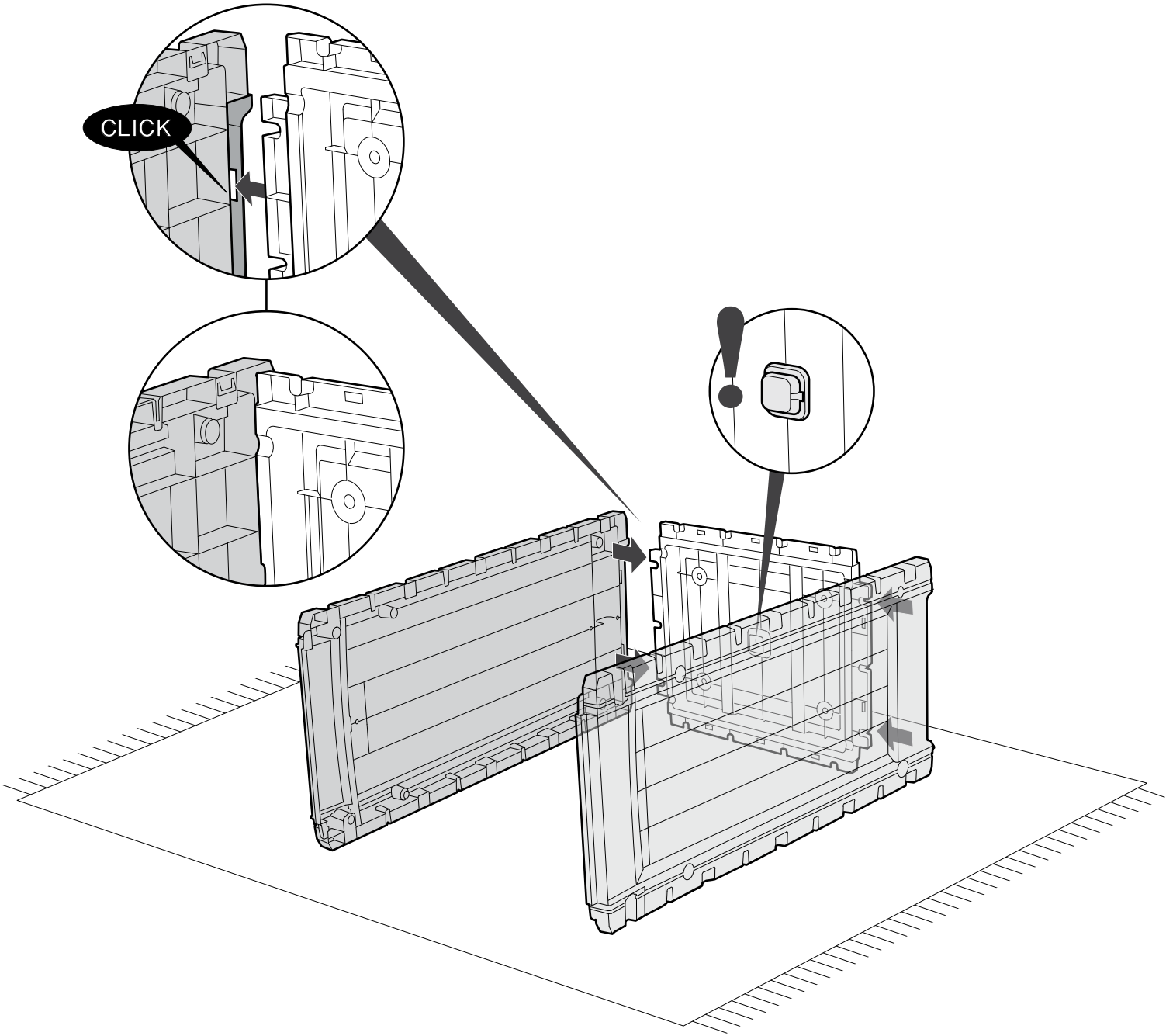

10

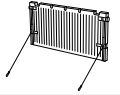

PSS+MTC



PP (X2)

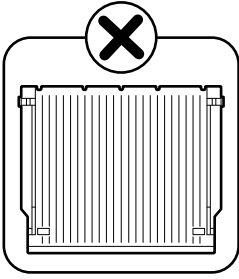
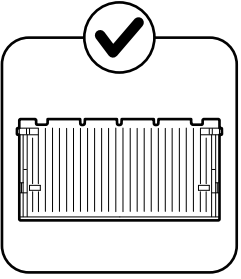

1

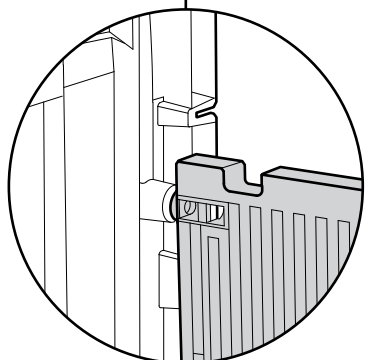
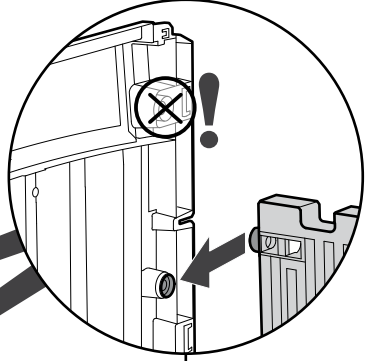
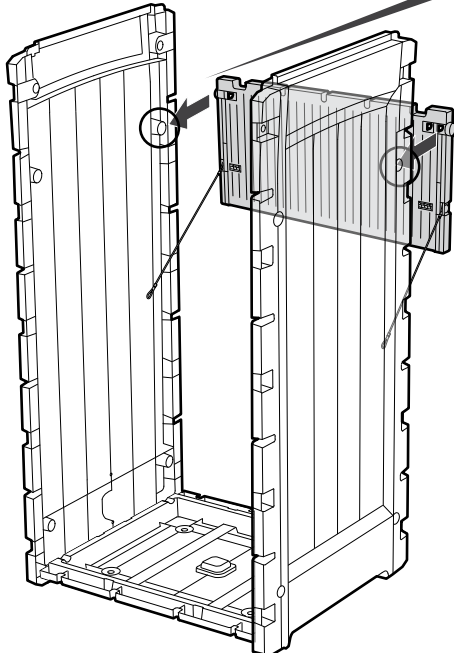

2

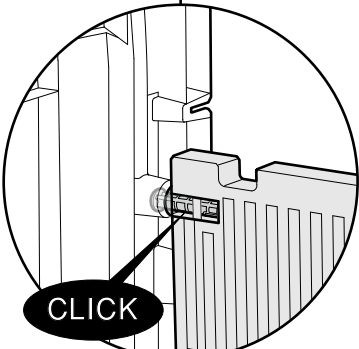
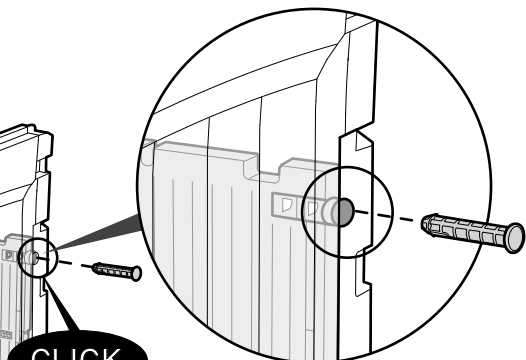
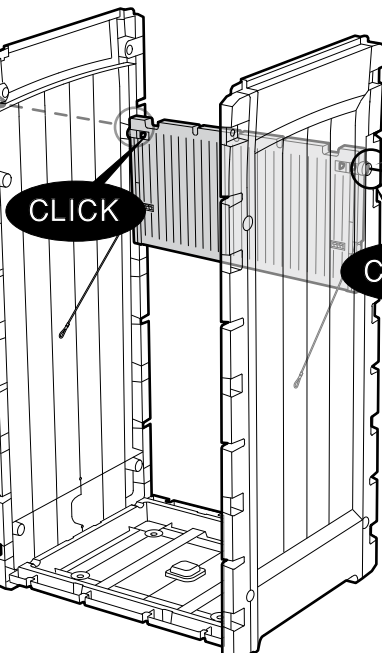
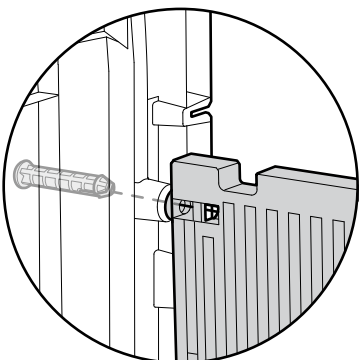

CLICK

CLICK

CLICK

11



PSL+MTC

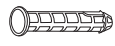

PP (X2)

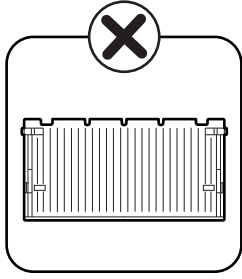
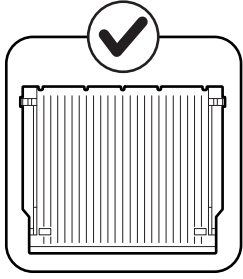

1

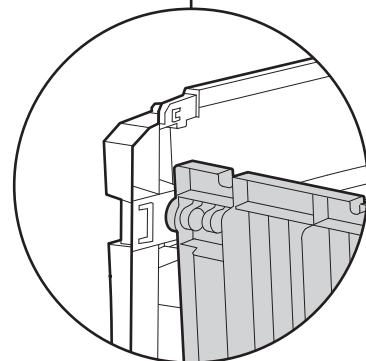
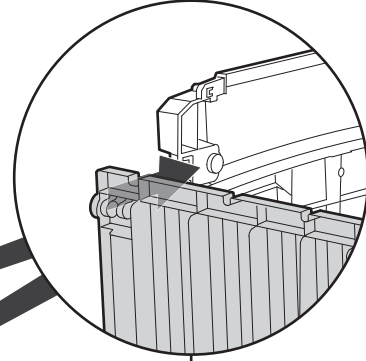
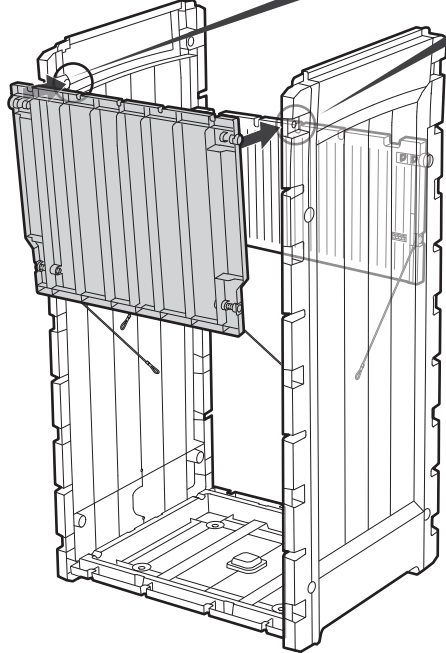

2

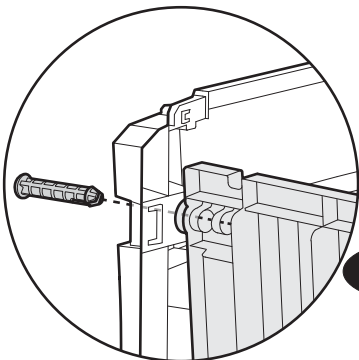

CLICK

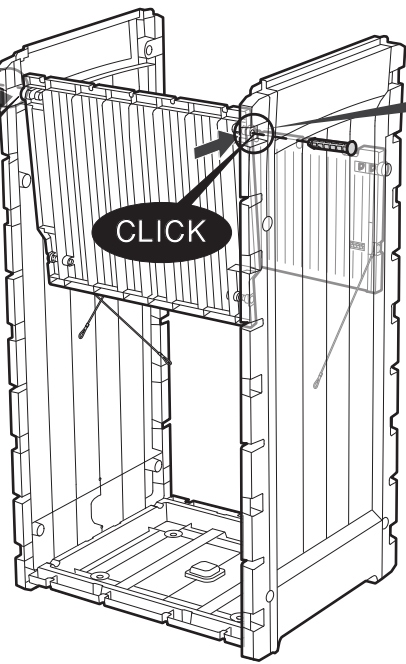

CLICK

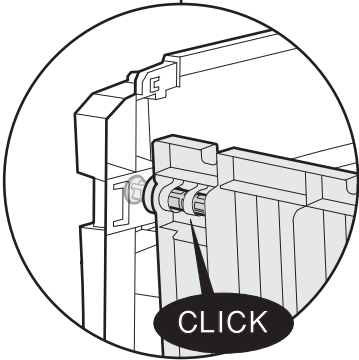
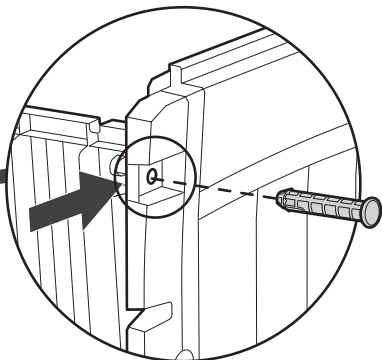

CLICK

12



PBF (X1)

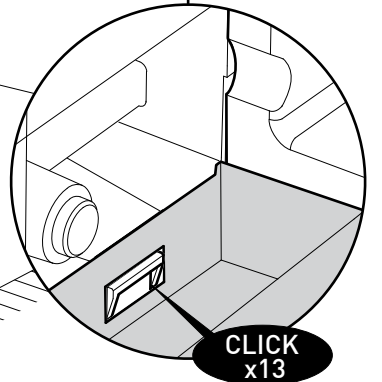
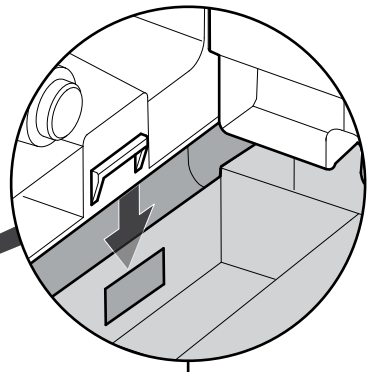
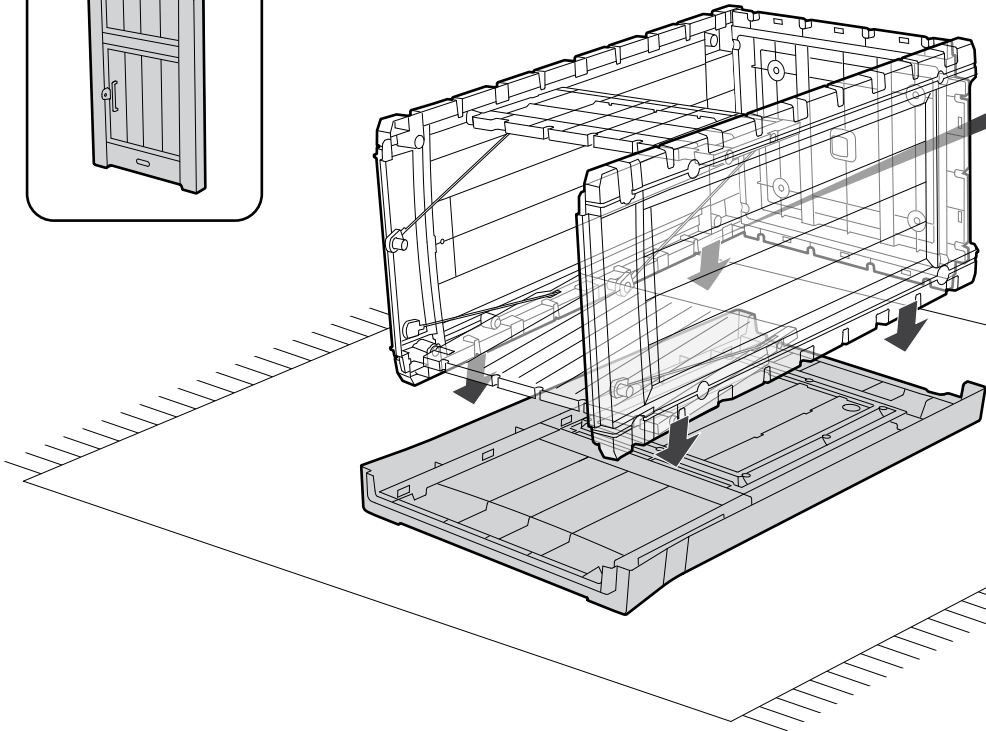
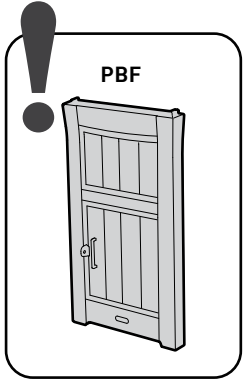

13



PBB (X1)

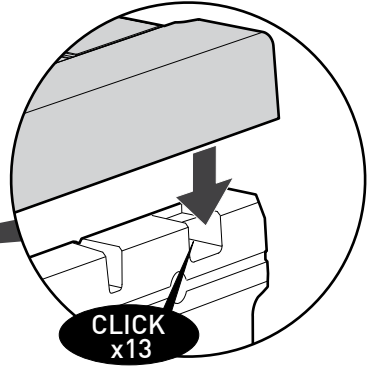
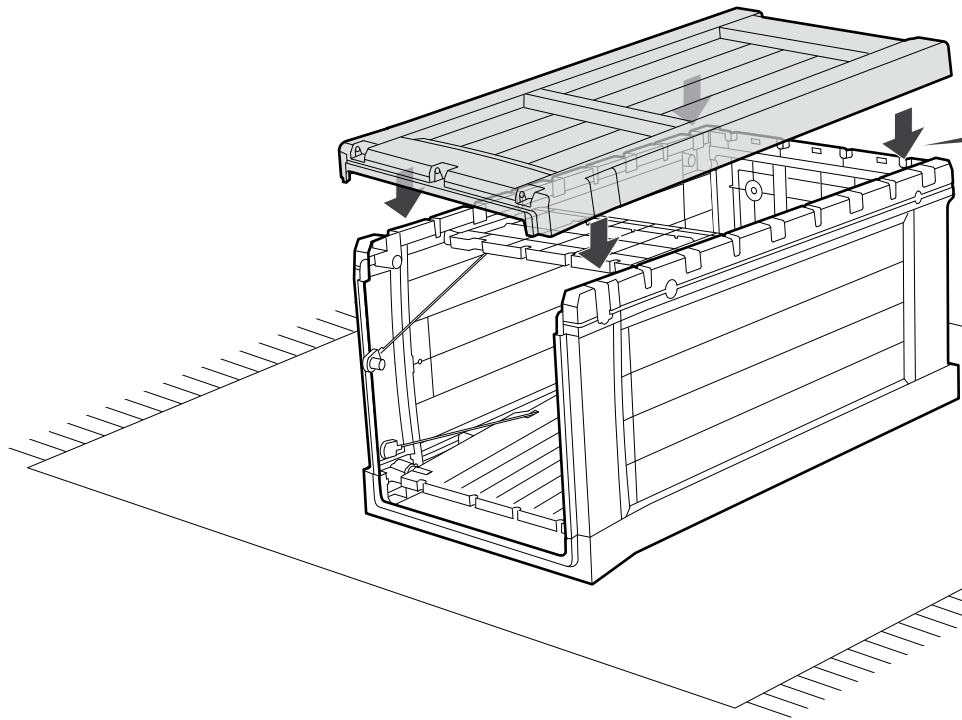

14

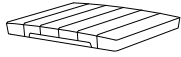

PBC (X1)



PP (X3)

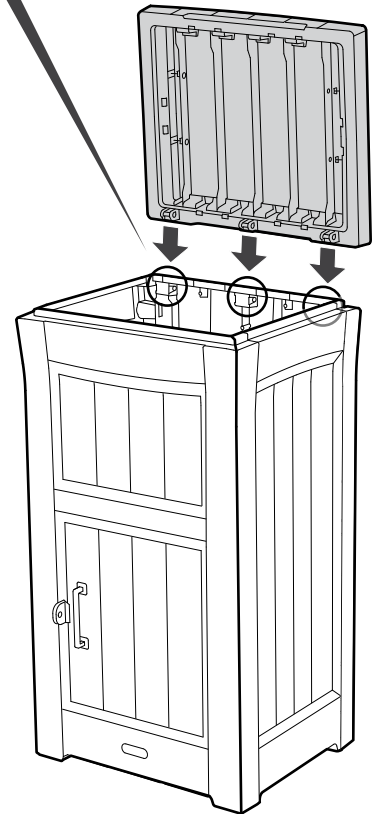
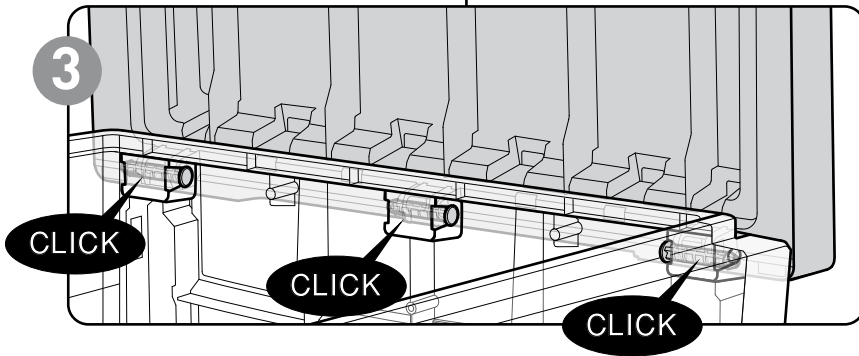
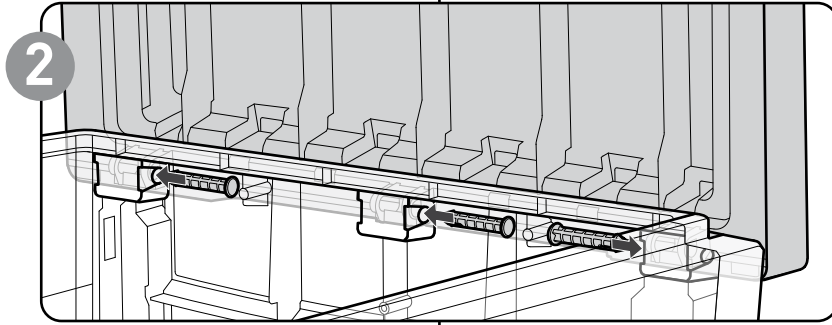
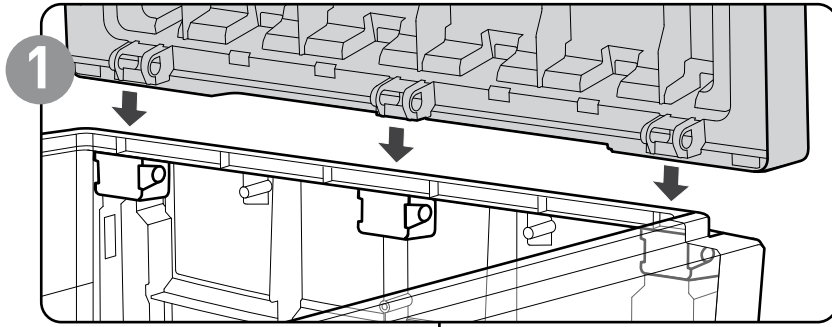

15

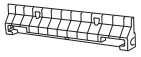

BSS (X1)



S14 (X3)

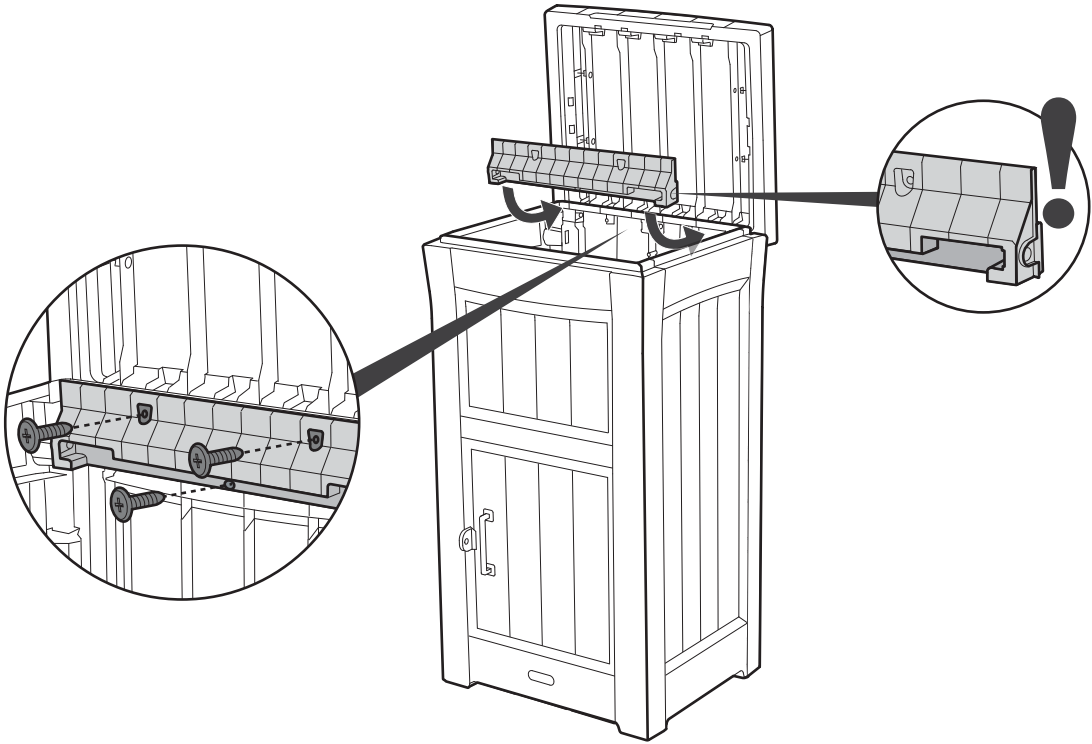

16



PP (X2)

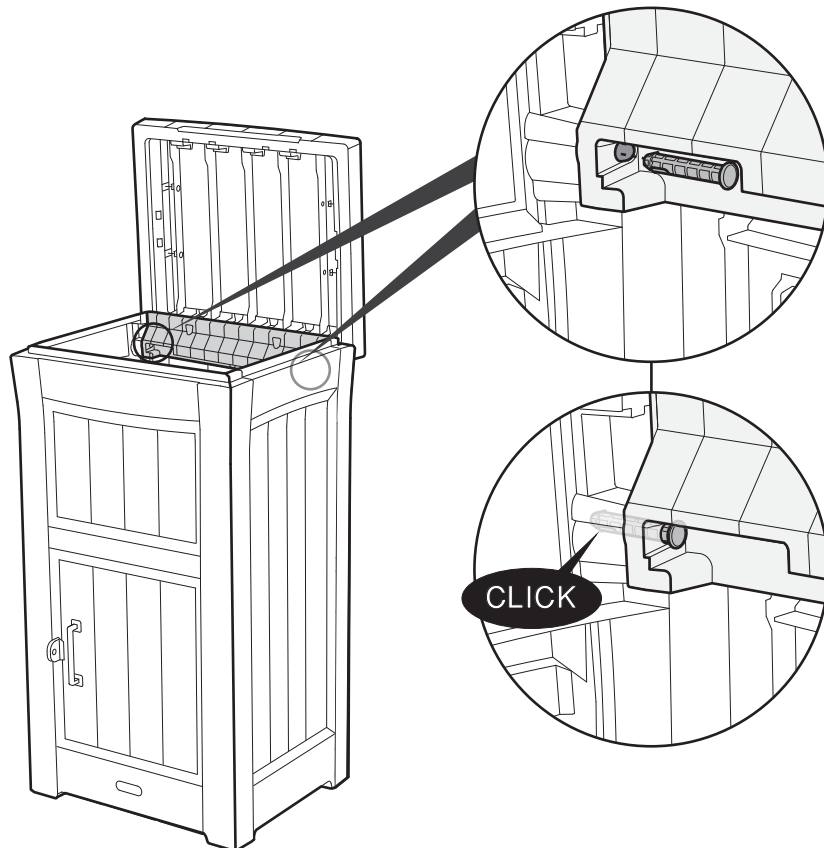



PSS+MTC



PCC (X2)

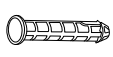

PP (X2)

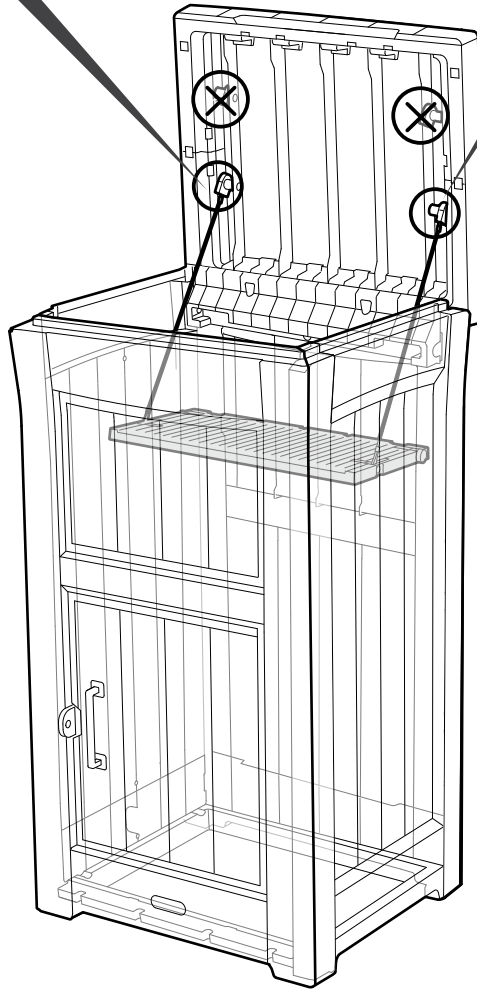
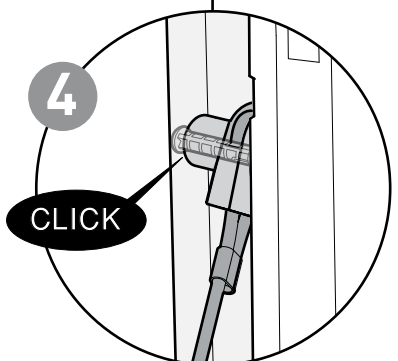
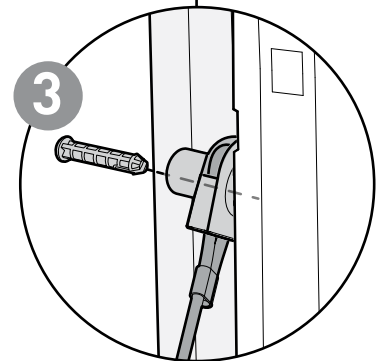
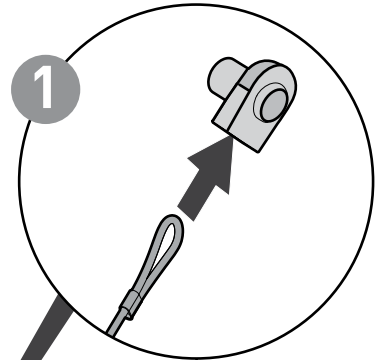
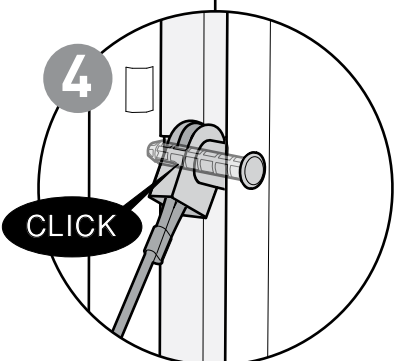
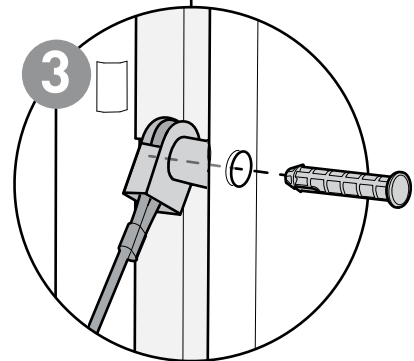
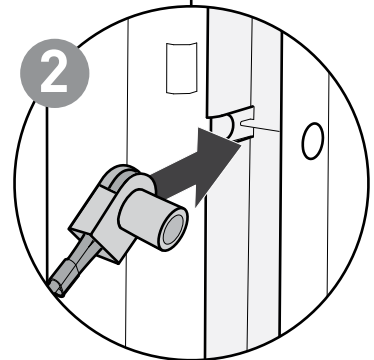
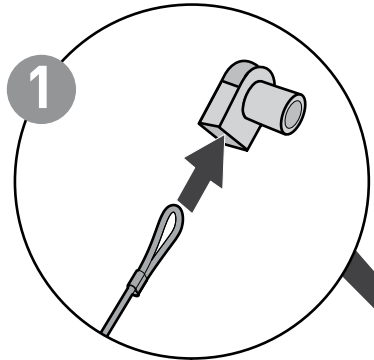
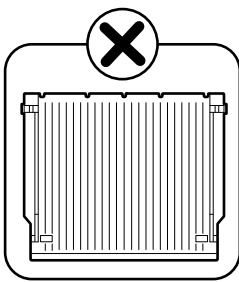
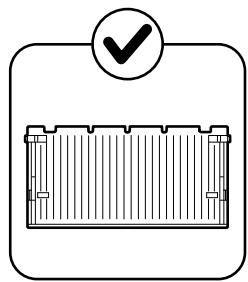

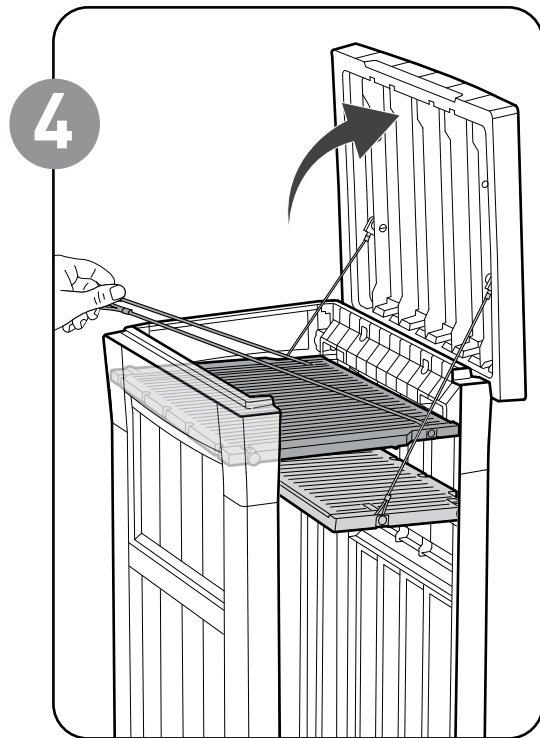
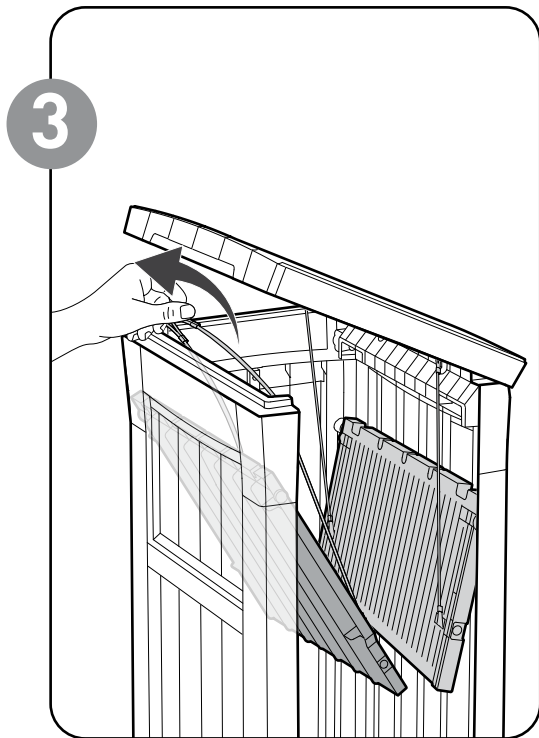
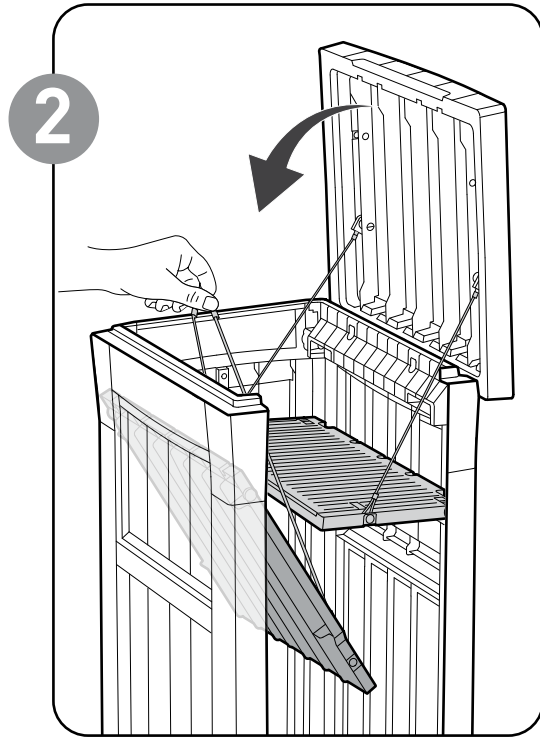
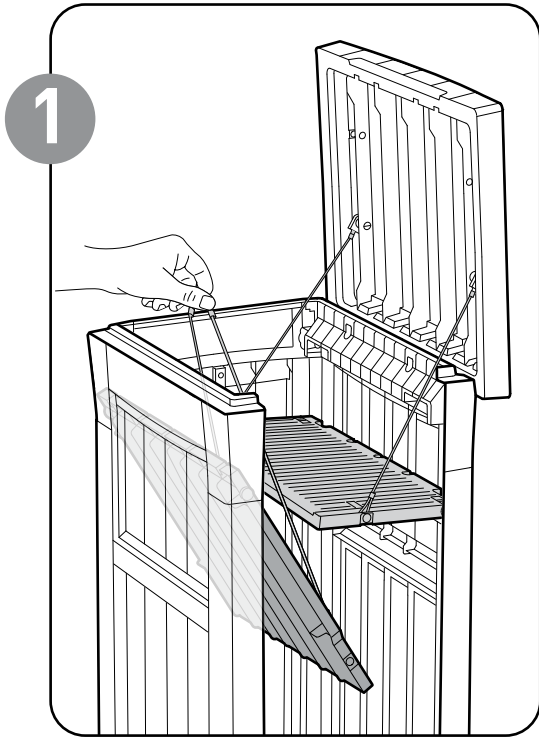

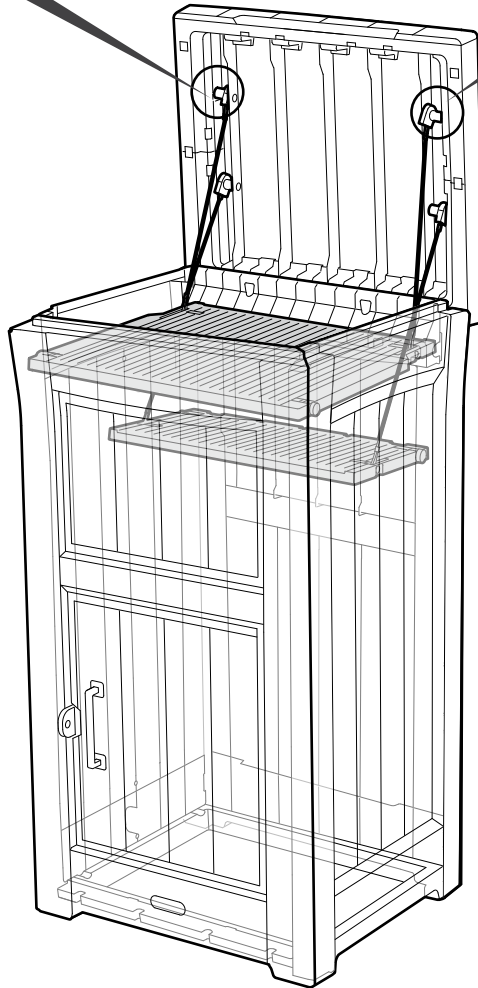
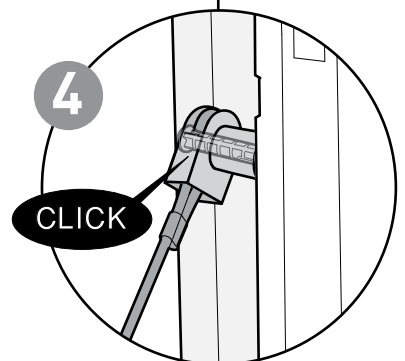
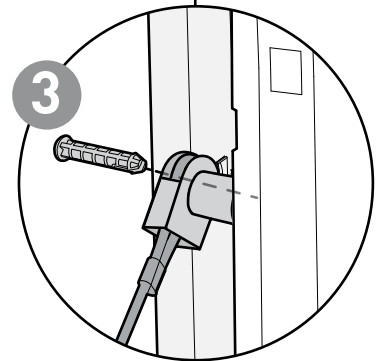
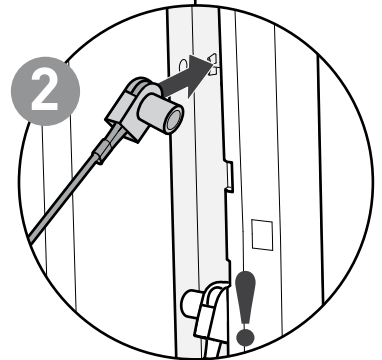
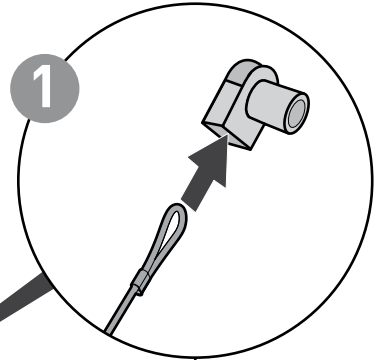
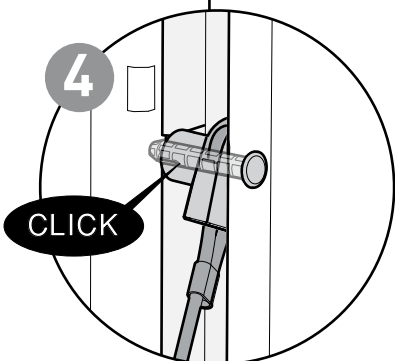
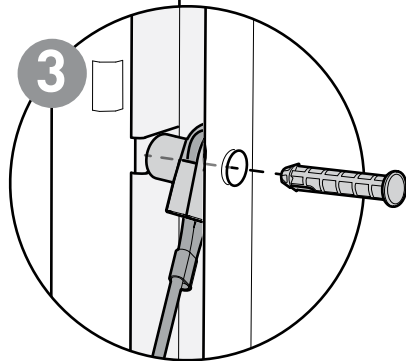
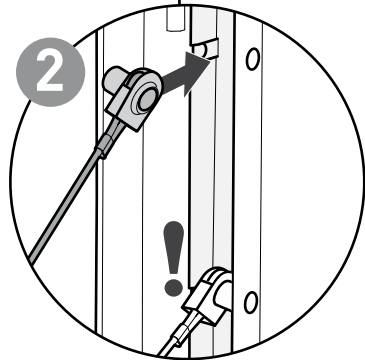
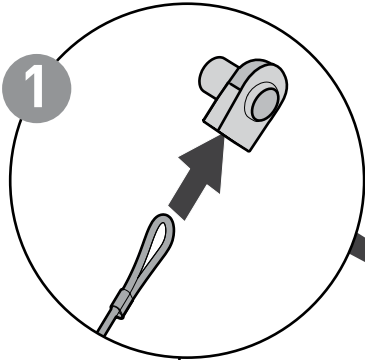
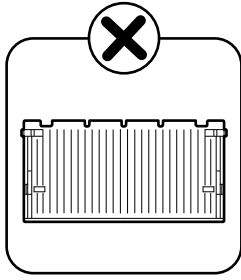
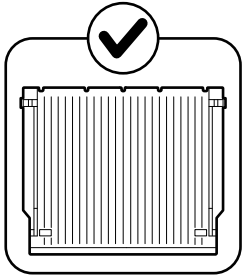

20



FLC (X1)

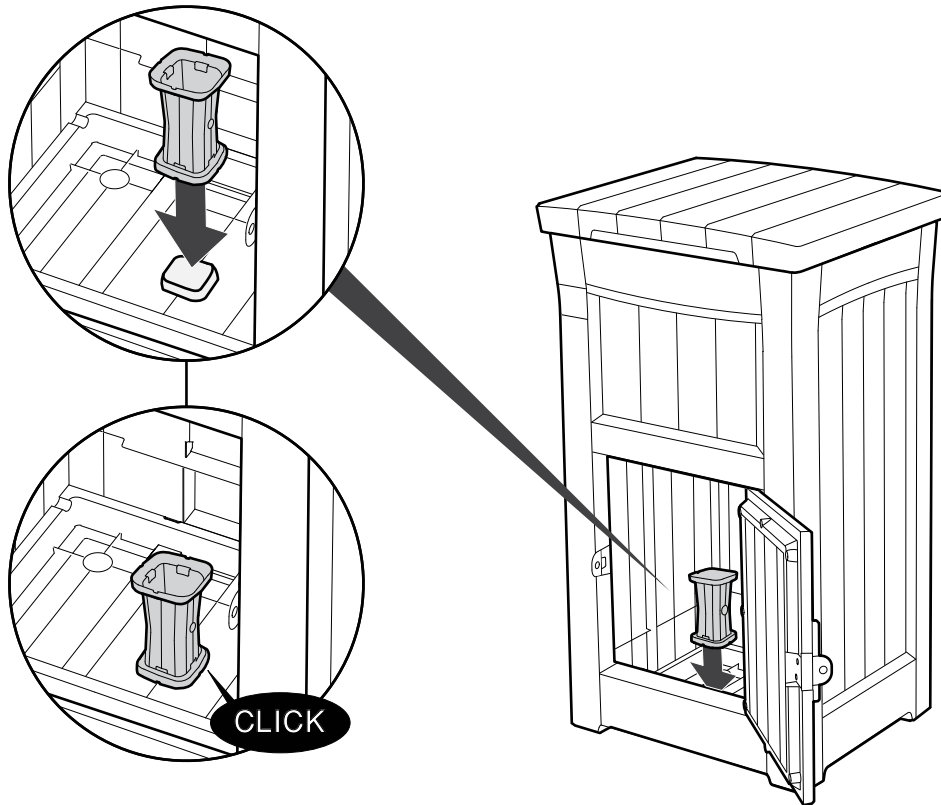

21

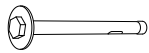

JS (X4)

REQUIRED TOOLS | OUTILS EXIGÉS | HERRAMIENTAS NECESARIAS | BENÖTIGTE WERKZEUGE | BENODIGD GEREEDSCHAP | ATTREZZATURA OCCORRENTE | FERRAMENTAS NECESSÁRIAS

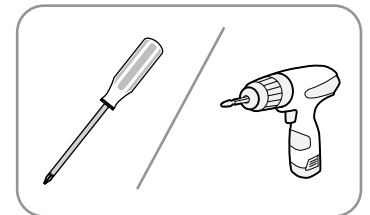
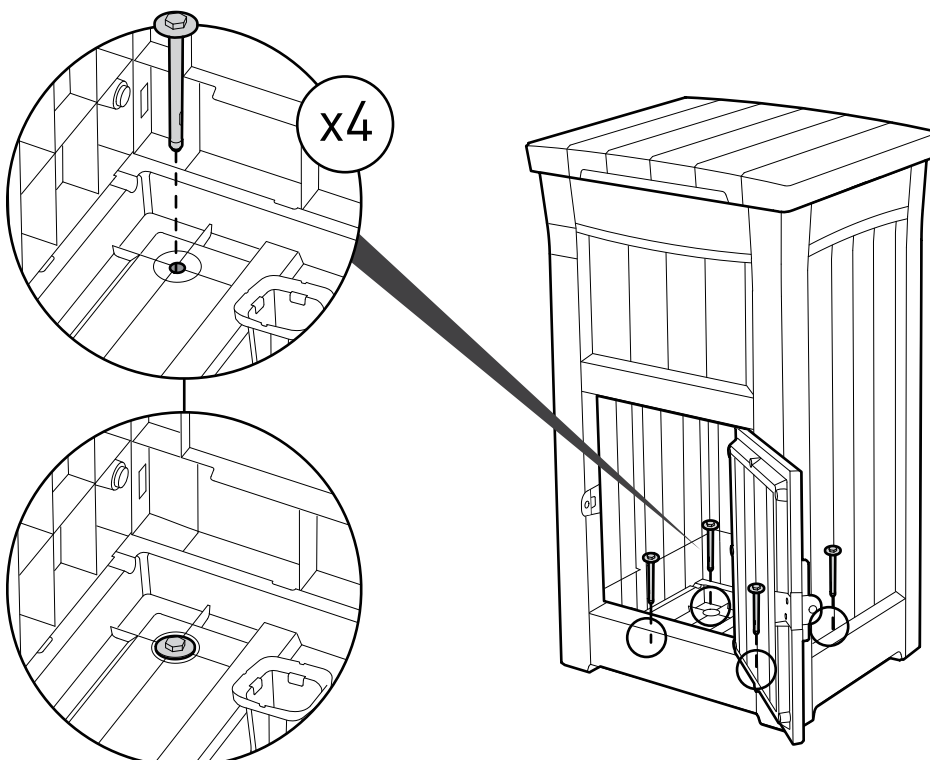

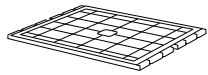

PFT (X1)

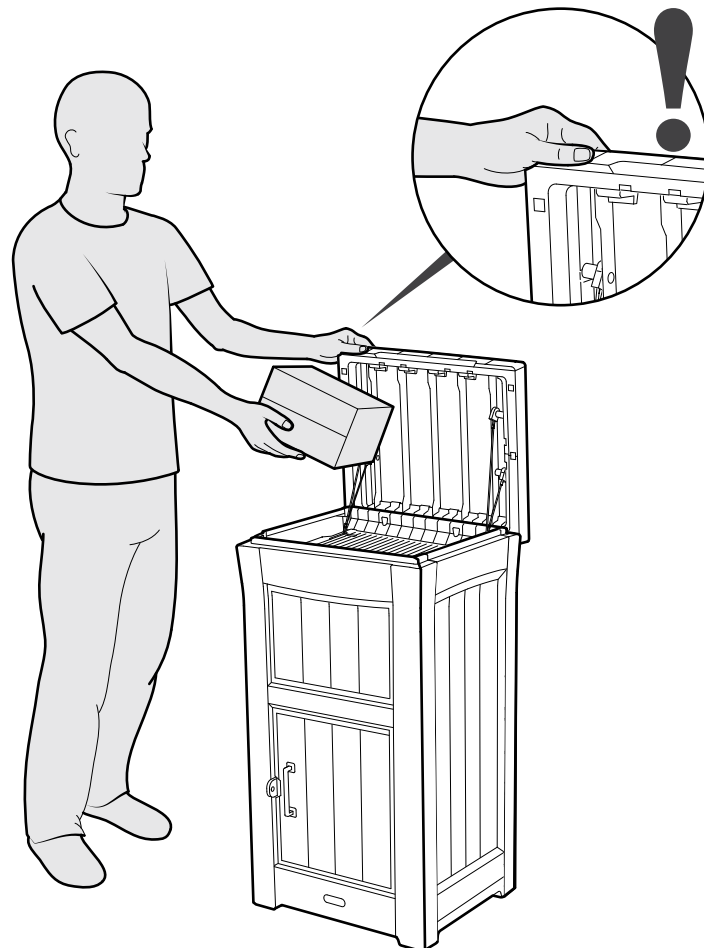
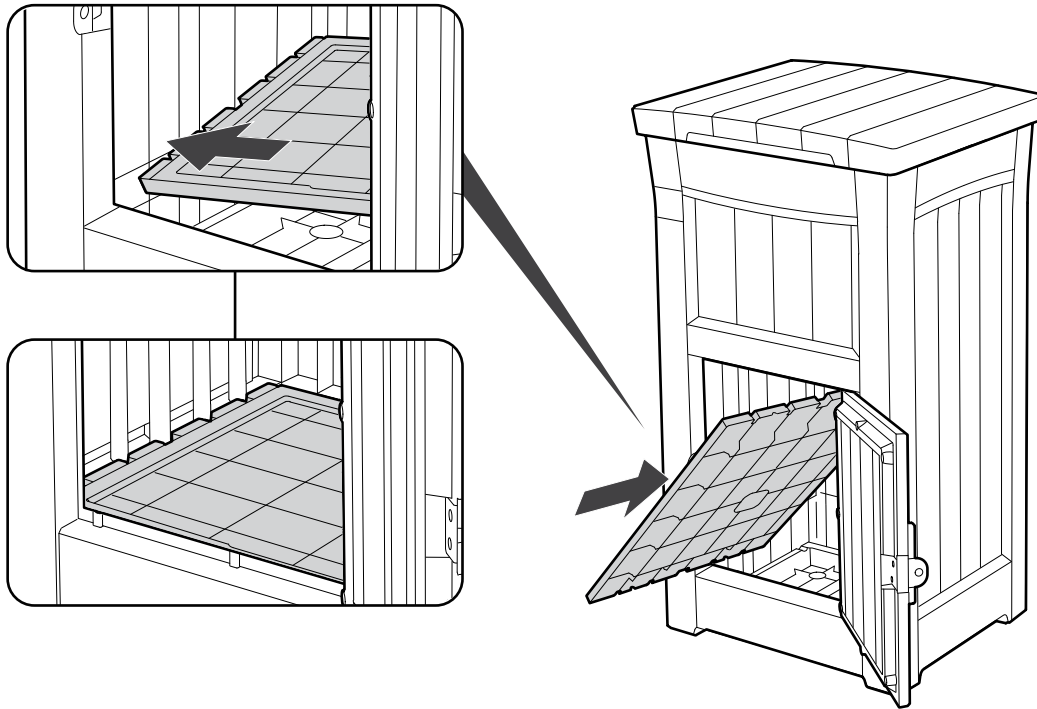

LIMITED 2-YEAR WARRANTY

Keter's renowned reputation for fine products is a result of its dedication and commitment to quality, design and innovation. The entire range of sheds and boxes is manufactured from high quality materials under rigorous control and supervision. In case a problem should occur, please address your claim to customer service either by phone or through our website: www.keter.com. The warranty is valid as of the date of purchase and a dated proof of purchase should be presented on request. Keter continuously tests its products for durability & stability and will replace, at its discretion, any product or part which fails due to structural defect or faulty workmanship, or which fails due to fading of color, for a 2-year period from the initial date of purchase. Damage caused by: use of force, incorrect handling, inappropriate use, neglect, commercial use or use other than for personal or household purposes; damages resulting from alteration, painting, or assembly not in accordance with the User's Manual and damages caused as a result of storage above the capacity load of the product, are excluded from this warranty. In addition, this limited warranty does not apply to damage resulting from exceptional wind effects (including, but not limited to, storms). After a claim has been settled, the guarantee period will continue to be counted and shall terminate upon its expiry date. Keter shall not be responsible for any damage caused by any reason whatsoever to goods stored in the Product. Please note that the products are produced from the finest raw materials, which are "clear": non-toxic and completely recyclable.

GARANTIE LIMITÉE DE 2 ANS

La renommée croissante de Keter pour l'excellence de ses produits est le fruit de son engagement pour la qualité, la création et l'innovation. La gamme complète d'abris de jardin et de coffres a été fabriquée avec des matériaux de qualité, sous contrôle rigoureux. En cas de problème, veuillez adresser votre réclamation au service clientèle, par téléphone ou par le biais de notre site Internet: www.keter.com. La garantie prend effet à compter de la date d'achat, et une preuve d'achat datée devra être présentée sur demande. Keter teste constamment la solidité et la stabilité de ses produits et remplacera, si elle le juge nécessaire, tout produit ou partie de produit avéré défectueux du fait d'un défaut de fabrication ou de l'altération des couleurs, pendant une période de 2 ans à compter de la date d'achat. Les dommages causés par l'usage de la force, un maniement impropre, une utilisation inappropriée du produit, une négligence, un usage commercial ou un usage à des fins non privées ; de même que les dommages résultant d'une modification, d'une coloration ou d'un assemblage non effectué en conformité avec le manuel de l'utilisateur ; ainsi que les dommages causés par un stockage dépassant la capacité pondérale du produit, sont exclus de cette garantie. En outre, cette garantie limitée ne s'applique pas aux dommages résultant des effets exceptionnels du vent (y compris, mais pas limité aux tempêtes). Après avoir formulé votre réclamation, la période de la garantie restera valide jusqu'à sa date d'expiration. Keter décline toute responsabilité pour tout dommage de quelque nature que ce soit des biens emmagasinés dans le produit. À noter que les articles sont fabriqués avec des matières premières de qualité supérieure, déclarées "écologiques": non toxiques et entièrement recyclables.

2 JAHRES -GARANTIE MIT BESCHRÄNKTER HAFTUNG

Der gute Ruf von Keters Produkten begründet sich auf die Verpflichtung zu Qualität, Design und Innovation. Das gesamte Produkt-Spektrum der Gartenschuppen und Truhen wird aus hochwertigen Materialien unter strenger Kontrolle hergestellt. Sollte ein Problem auftreten, wenden Sie sich bitte telefonisch oder über unsere Homepage www.keter.com an unseren Kundendienst. Die Garantiezeit beginnt mit dem Kaufdatum. Bitte bewahren Sie die datierte Kaufquittung für eventuelle Rückfragen auf. Keter prüft seine Produkte ständig auf lange Lebensdauer und Stabilität. Sollten trotzdem Mängel auftreten, die auf Material- oder Verarbeitungsfehler zurückzuführen sind, oder sollte die Farbe verblassen, wird jedes mangelhafte Produkt oder Teil innerhalb eines Zeitraums von 2 Jahren ab dem Kaufdatum ersetzt. Von dieser Garantie ausgeschlossen sind Schäden, die durch Gewaltanwendung, unsachgemäße Bedienung oder Behandlung, Nachlässigkeit, kommerzielle Nutzung oder andere Nutzungen außer zu persönlichen Zwecken oder im Haushalt verursacht wurden. Schäden, die durch Veränderungen am Produkt, das Anstreichen oder unsachgemäße, vom Benutzerhandbuch abweichende Montage auftreten, ebenso wie Schäden, die auf das Überschreiten der zugelassenen Ladekapazität zurückzuführen sind, sind ebenfalls von der Garantie ausgeschlossen. Darüber hinaus deckt diese beschränkte Garantie Schäden, die auf außergewöhnliche Windbelastung (einschließlich, aber nicht nur Sturmschäden) zurückzuführen sind, nicht. Im Falle einer erledigten Reklamation wird die Garantiezeit weiterlaufen und der Garantieanspruch gilt nur bis zum ursprünglichen Ablaufdatum. Keter kann keine Verantwortung für Schäden an Waren übernehmen, die im Produkt gelagert werden, ganz egal aus welchen Gründen diese Schäden verursacht wurden. Bitte beachten Sie, dass unsere Produkte aus hochwertigen, umweltfreundlichen Rohmaterialien hergestellt werden und absolut ungiftig und vollständig recyclebar sind.

GARANTÍA LIMITADA POR 2 AÑOS

La afamada reputación que Keter ha ganado por sus excelentes productos es el resultado de su dedicación y compromiso hacia la calidad, el diseño y la innovación. La gama completa de cobertizos y cajas se fabrica con materiales de óptima calidad y bajo estrictos controles y supervisión. En caso de surgir algún inconveniente, rogamos tenga a bien elevar su queja al servicio de atención al cliente, ya sea vía telefónica o a través de nuestro sitio en la Web: www.keter.com. La garantía es válida a partir de la fecha de compra y, a solicitud, deberá presentarse un comprobante de compra con fecha. Keter pone a prueba sus productos en forma constante para determinar la durabilidad y estabilidad de los mismos. A criterio de Keter se reemplazará todo producto o parte del mismo que presente fallas como consecuencia de un defecto estructural o de mano de obra, o que se deteriore por decoloración, durante un período de 2 años, contados a partir de la fecha de compra inicial. Los daños causados por: el uso de la fuerza, la manipulación incorrecta, la utilización inadecuada, el descuido, el uso comercial o con un propósito diferente del personal o doméstico; los daños que resultaran de modificaciones, pinturas o armado no realizados de conformidad con las explicaciones del Manual de instrucciones y los daños causados por exceder la capacidad de carga de almacenamiento del producto, quedan excluidos de esta garantía. Además, esta garantía limitada no se aplica a los daños que resulten de los efectos de un viento excepcional (incluso, aunque no taxativamente, de las tormentas). Una vez que se haya remediado un reclamo, el período de garantía seguirá contando y finalizará en su fecha de vencimiento. Keter no asume responsabilidad alguna por ningún daño que hubiera sufrido cualquier artículo almacenado en el producto, cualquiera fuera su causa. Tenga en cuenta que los productos se fabrican con materias primas de excelente calidad, que son "ecológicas": es decir, no tóxicas y completamente reciclables.

2-JARIGE BEPERKTE GARANTIE

Keter heeft aan zijn toewijding en verplichtingen ten opzichte van kwaliteit, ontwerp en vernieuwing voor zijn prachtige producten, zijn vermaarde reputatie te danken. De gehele serie schuurtjes en dozen zijn, onder strenge controle en met toezicht van kwaliteitsmaterialen vervaardigd. In geval dat zich een probleem voordoet, dient u deze of via de telefoon, of via onze website, bij de klantenservice voor te leggen. Het adres voor onze website is: www.keter.com. De garantie is vanaf de aankoopdatum geldig en bij verzoek moet een aankoopbewijs met datum worden getoond. Keter test zijn producten continu op houdbaarheid & betrouwbaarheid en zal, gedurende een periode van 2 jaar vanaf de eigenlijke aankoopdatum, naar eigen goeddunken elk product of onderdeel met constructiefouten, of met kleurvervaging, vervangen. De garantie dekt niet de hierop volgende aangegeven schade: schade veroorzaakt door gewelddadig gebruik, onjuist gebruik, verwaarlozing, handelsgebruik anders dan persoonlijk of huishoudelijk gebruik, schade berokkent door aangebrachte veranderingen, verven of montage verricht op een andere wijze als beschreven wordt in de handleiding en schade veroorzaakt door het opslaan boven het vermogenonderdeel van het product. Daarnaast is deze beperkte garantie niet van toepassing op schade die ontstaan is als resultaat van buitengewone windeffecten (inclusief, maar niet beperkt tot, stormen). Nadat een claim is gevestigd, gaat de garantieperiode gewoon door tot de vervaldatum, waarop het zal worden beëindigd. Keter kan niet aansprakelijk worden gesteld voor enige schade die door een of andere reden is ontstaan tijdens het opslaan van het product. Denk eraan dat de producten van de fijnste ruwe materialen zijn gemaakt die geheel "zuiver" zijn: niet giftig en geheel recyclebaar.

GARANZIA LIMITATA DI 2 ANNI

L'ottima reputazione di cui gode Keter per i suoi prodotti è il risultato di una dedizione e di un impegno costante verso la qualità, il design e l'innovazione. L'intera gamma degli armadietti e dei box viene prodotta con materiali di prima qualità, sotto un controllo e una supervisione rigorosi. Se dovesse presentarsi un problema, presentare reclamo al servizio d'assistenza, per telefono o attraverso il nostro sito Web: www.keter.com. La garanzia è valida a partire dalla data di acquisto e su richiesta deve essere presentata una prova di acquisto datata. Keter tiene continuamente sotto controllo la durevolezza e la solidità dei suoi prodotti ed è pronta a sostituire, a sua discrezione, qualsiasi prodotto o parte di esso presentante un'alterazione provocata da un difetto strutturale o dal processo di produzione, o un'alterazione causata da un colore sbiadito, per un periodo di 2 anni a partire dalla data di acquisto. I danni causati da: uso di forza, uso non corretto, utilizzo inappropriato, negligenza, uso commerciale o uso diverso da quello personale o per fini domestici; danni derivanti da alterazione, pittura, o montaggio non eseguito in conformità con il manuale d'istruzioni; e danni provocati in conseguenza di condizioni di magazzinaggio eccedenti la capacità di carico del prodotto, sono esclusi dalla presente garanzia. Inoltre, questa garanzia limitata non si applica ai danni causati dagli effetti di condizioni meteo eccezionali (inclusi, ma non limitati ai temporali). Dopo aver stabilito un reclamo, il periodo di garanzia continuerà ad essere calcolato e terminerà alla sua data di scadenza. Keter non sarà ritenuta responsabile per danni causati da una qualunque ragione ai beni contenuti nel Prodotto. Si noti che i prodotti sono costruiti dalle migliori materie prime, che sono "sicure": non tossiche e completamente riciclabili.

GARANTIA LIMITADA DE 2 ANOS

A célebre reputação da Keter pelos seus produtos distintos é resultante da sua dedicação e compromisso com a qualidade, o design e a inovação. Toda a gama de abrigos de jardim e caixas é produzida com materiais de elevada qualidade que são sujeitos a um controlo e supervisão rigorosos. Se ocorrer algum problema com o produto, faça a sua reclamação junto do serviço de apoio ao cliente, através do telefone ou do nosso site: www.keter.com. A Garantia é válida a partir da data de compra e deve ser apresentada uma prova de compra, se solicitado. A Keter testa continuamente os seus produtos quanto a durabilidade e estabilidade, e procederá, da forma que achar conveniente, à substituição de qualquer produto ou parte do mesmo que esteja danificada como consequência de defeito na estrutura, defeito de fabrico ou descoloração do produto, durante um período de 2 anos, a contar da data da compra. Os danos causados pelo uso da força, manuseamento incorrecto, utilização indevida, negligência, uso comercial ou outro uso que não o relacionado com fins domésticos ou pessoais, danos causados por alteração, pintura ou montagem que não sejam em conformidade com o Guia do Utilizador, assim como danos causados pelo armazenamento de artigos acima da capacidade de carga do produto, estejam excluídos desta garantia. A lém disso, esta garantia limitada não abrange danos resultantes dos efeitos de ventos anormais (incluindo, entre outros, tempestades). A pós a resolução de uma reclamação, o período da garantia continuará a ser contado e deve terminar após o fim da data de validade. A Keter não será responsável por nenhuns danos causados por qualquer motivo nos bens armazenados no Produto. Note que os produtos são produzidos a partir das melhores matérias-primas, as quais são "limpas": não-tóxicas e totalmente recicláveis.

CARE & SAFETY

In case of fire, do not attempt to extinguish any burning polypropylene with water.
It is of utmost importance to assemble all of the parts according to the directions. Do not skip any step.
Wear safety goggles and always follow the manufacturer's instructions when using power tools.
Using a stiff brush or abrasive cleaner could damage the box.
Hot items such as recently used grills, blowtorches, etc., must not be stored in the box.
Not designed for carrying items.
After rain, wipe box with cloth before opening.
Unsuitable for storage of flammable or corrosive substances.
Do not stand on lid.
To prevent risk of suffocation, do not allow children to play inside the box.
For domestic use.

PRÉCAUTIONS ET SÉCURITÉ

En cas d'incendie, ne pas tenter d'éteindre le polypropylène brûlé avec de l'eau.
Il est impératif de monter toutes les parties selon les instructions. Ne pas omettre une quelconque étape.
Portez des lunettes de protection et suivez toujours les instructions du fabricant lorsque vous utilisez des outils électriques.
Utiliser une brosse dure ou un produit d'entretien abrasif risquerait de l'endommager.
Des articles chauds, tels que des grills non refroidis, des chalumeaux, etc., ne doivent pas être entreposés dans la boîte.
Non conçue pour le transport d'objets.
Après la pluie, essuyer la boîte avec un chiffon avant de l'ouvrir.
Ne convient pas pour le stockage de substances inflammables ou caustiques.
Ne pas se tenir debout sur le couvercle.
Pour empêcher tout risque d'étouffement, ne pas laisser les enfants jouer à l'intérieur de la boîte.
Pour usage domestique.

PFLEGE - UND SICHERHEITSHINWEISE

Im Brandfall sollten Sie nicht versuchen, brennendes Polypropylen mit Wasser zu löschen.
Es ist äußerst wichtig, dass alle Teile der Anleitung zufolge montiert werden. Bitte lassen Sie keine Schritte aus.
Tragen Sie beim Gebrauch von Elektrowerkzeugen eine Schutzbrille und folgen Sie stets der Anleitung des Herstellers.
Die Verwendung von harten Bürsten oder anderen ungeeigneten Putzgeräten kann das Material beschädigen.
Noch heiße Gegenstände wie Grillgeräte, Fackeln usw. dürfen nicht in der Truhe aufbewahrt werden.
Nicht zum Transport von Gegenständen geeignet.
Nach einem Regen sollte die Truhe vor dem Öffnen mit einem Tuch abgewischt werden.
Nicht zur Aufbewahrung von entzündbaren oder ätzenden Mitteln vorgesehen.
Bitte nicht auf den Deckel treten.
Um einer Erstickungsgefahr vorzubeugen, sollte Kindern das Spielen in der Truhe untersagt werden.
Für den Privatgebrauch.

CUIDADO Y SEGURIDAD

En caso de incendio, no intente extinguir polipropileno en llamas con agua.
Es de suma importancia armar todas las partes de acuerdo con las instrucciones. No omita ninguno de los pasos.
Use anteojos protectores; al usar herramientas eléctricas, siga siempre las instrucciones del fabricante.
La utilización de un cepillo duro o de un producto de limpieza abrasivo podría dañar el arcón.
Los objetos calientes - como por ejemplo, las parrillas recién usadas, sopletes, etc. - no deben guardarse en el arcón.
No está diseñado para el traslado de objetos.
Después de una lluvia, limpiar el arcón con un paño antes de abrirlo.
No es apropiado para el almacenamiento de sustancias inflamables o cáusticas.
No pararse sobre la tapa.
Para evitar el riesgo de asfixia, no permita que los niños jueguen dentro del arcón.
Para uso doméstico.

ZORG EN VEILIGHEID

In geval van brand NIET proberen om brandend polypropyleen met water te blussen.
Het is uitermate belangrijk alle onderdelen volgens de richtlijnen te monteren. Sla geen van de stappen over.
Draag een veiligheidsbril en volg altijd de instructies van de fabrikant als u elektrisch gereedschap gebruikt.
Een harde borstel of schuurmiddel kan schade veroorzaken aan het schuurtje.
U mag geen warme voorwerpen zoals een pas gebruikte grill, soldeerlamp, enz. in de kist opslaan.
De kist is niet ontworpen om voorwerpen te dragen.
Nadat het heeft geregend, dient u de kist met een doek af te vegen alvorens u deze opent.
Ongeschikt voor het opslaan van brandbare of gevaarlijke materialen.
U mag niet op de klep staan.
Om de kans op verstikking te voorkomen, raden wij u aan kinderen niet in de kist te laten spelen.
Voor huishoudelijk gebruik.

MANUTENZIONE E SICUREZZA

In caso di incendio, non usare l'acqua per spegnere il fuoco sugli oggetti in polipropilene.
È della massima importanza assemblare tutte le parti seguendo accuratamente le istruzioni. Non saltare nessuno dei passaggi descritti.
Indossare occhiali di sicurezza e seguire sempre le istruzioni del produttore durante l'utilizzo di strumenti elettrici.
L'uso di una spazzola dura o di un detersivo abrasivo, potrebbe danneggiarlo.
Non riporre nell'armadietto elementi roventi, come una graticola usata di recente, un bruciatore di saldatura, ecc.
L'armadietto non è stato progettato per sorreggere altri utensili.
Dopo la pioggia, asciugare il contenitore con un panno prima di aprirlo.
Non adatto per la conservazione di sostanze infiammabili o corrosive.
Non appoggiarsi al coperchio.
Per prevenire il rischio di soffocamento, non permettere ai bambini di giocare all'interno del contenitore.
Per uso domestico.

MANUTENÇÃO E SEGURANÇA

Em caso de incêndio, não tente apagar material de polipropileno em combustão com água.
É de extrema importância que monte todas as partes de acordo com as instruções. Não omita nenhum passo.
Utilize sempre óculos de proteção e siga as instruções do fabricante quando utilizar ferramentas elétricas.
Se utilizar uma escova dura ou um detergente abrasivo, poderá danificar a caixa.
Elementos que estejam quentes, como, por exemplo, grelhas utilizadas recentemente, maçaricos, etc. não devem ser guardados na caixa.
Este produto não foi concebido para transportar artigos.
Se apanhar chuva, seque a caixa com um pano antes de a abrir.
Não deve ser utilizado para guardar substâncias inflamáveis ou corrosivas.
Não se apoie na tampa da unidade.
Para evitar riscos de asfixia, não deixe as crianças brincarem dentro da caixa.
Para utilização doméstica.