

# AXOR<sup>®</sup>

**hansgrohe**

<b>DE</b>	Gebrauchsanleitung / Montageanleitung	<b>2</b>			
<b>FR</b>	Mode d'emploi / Instructions de montage	<b>4</b>			
<b>EN</b>	Instructions for use / assembly instructions	<b>6</b>			
<b>IT</b>	Istruzioni per l'uso / Istruzioni per Installazione	<b>8</b>			
<b>ES</b>	Modo de empleo / Instrucciones de montaje	<b>10</b>			
<b>NL</b>	Gebruiksaanwijzing / Handleiding	<b>12</b>			
<b>DK</b>	Brugsanvisning / Monteringsvejledning	<b>14</b>			
<b>PT</b>	Instruções para uso / Manual de Instalação	<b>16</b>			
<b>PL</b>	Instrukcja obsługi / Instrukcja montażu	<b>18</b>			
<b>CS</b>	Návod k použití / Montážní návod	<b>20</b>			
<b>SK</b>	Návod na použitie / Montážny návod	<b>22</b>			
<b>ZH</b>	用户手册 / 组装说明	<b>24</b>			
<b>RU</b>	Руководство пользователя / Инструкция по монтажу	<b>26</b>			
<b>HU</b>	Használati útmutató / Szerelési útmutató	<b>28</b>			
<b>FI</b>	Käyttöohje / Asennusohje	<b>30</b>			
<b>SV</b>	Bruksanvisning / Monteringsanvisning	<b>32</b>			
<b>LT</b>	Vartotojo instrukcija / Montavimo instrukcijos	<b>34</b>			
<b>HR</b>	Upute za uporabu / Uputstva za instalaciju	<b>36</b>			
<b>TR</b>	Kullanım kılavuzu / Montaj kılavuzu	<b>38</b>			
<b>RO</b>	Manual de utilizare / Instrucțiuni de montare	<b>40</b>			
<b>EL</b>	Οδηγίες χρήσης / Οδηγία συναρμολόγησης	<b>42</b>			
<b>SL</b>	Navodilo za uporabo / Navodila za montažo	<b>44</b>			
<b>ET</b>	Kasutusjuhend / Paigaldusjuhend	<b>46</b>			
<b>LV</b>	Lietošanas pamācība / Montāžas instrukcija	<b>48</b>			
<b>SR</b>	Uputstvo za upotrebu / Uputstvo za montažu	<b>50</b>			
<b>NO</b>	Bruksanvisning / Montasjeveiledning	<b>52</b>			
<b>BG</b>	Инструкция за употреба / Инструкция за употреба	<b>54</b>			
<b>SQ</b>	Udhëzuesi i përdorimit / Udhëzime rreth montimit	<b>56</b>			
<b>AR</b>	دليل الاستخدام / تعليمات التجميع	<b>59</b>			



**Starck**  
10715000

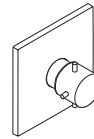

**Starck X**  
10717000



**Montreux**  
16815XXX



**Carlton**  
17712XXX



**Carlton**  
17716XXX

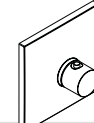

**Massaud**  
18741000

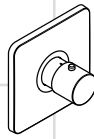

**Citterio M**  
34716000



**Steel**  
35715800

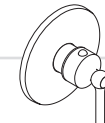

**Terrano**  
37711000

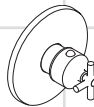

**Terrano**  
37716000



**Uno**  
38715000

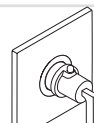

**Citterio**  
39711000

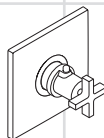

**Citterio**  
39716000



**Bouroullec**  
19702000



## Sicherheitshinweise

- ⚠ Bei der Montage müssen zur Vermeidung von Quetsch- und Schnittverletzungen Handschuhe getragen werden.
- ⚠ Das Produkt darf nur zu Bade-, Hygiene- und Körperreinigungszwecken eingesetzt werden.
- ⚠ Kinder, sowie Erwachsene mit körperlichen, geistigen und / oder sensorischen Einschränkungen dürfen nicht unbeaufsichtigt das Produkt benutzen. Personen die unter Alkohol- oder Drogeneinfluss stehen, dürfen das Produkt nicht benutzen.
- ⚠ Große Druckunterschiede zwischen den Kalt- und Warmwasseranschlüssen müssen ausgeglichen werden.

## Montagehinweise

Die Armatur muss nach den gültigen Normen montiert, gespült und geprüft werden!

## Technische Daten

Betriebsdruck:	max. 1 MPa
Empfohlener Betriebsdruck:	0,1 - 0,5MPa
Prüfdruck:	1,6MPa
(1 MPa = 10 bar = 147 PSI)	
Heißwassertemperatur:	max. 80 °C
Empfohlene Heißwassertemperatur:	65 °C
Durchflussleistung bei 0,3 MPa:	ca. 58 l/min
Eigensicher gegen Rückfließen	

## Symbolerklärung



Kein essigsäurehaltiges Silikon verwenden!

## max. Safety Function (siehe Seite 62)

≈ 42 °C

Dank der Safety Function lässt sich die gewünschte Höchsttemperatur von z. B. max. 42 °C voreinstellen.



## Einjustieren (siehe Seite 63)

Nach erfolgter Montage muss die Auslauftemperatur des Thermostaten überprüft werden. Eine Korrektur ist erforderlich wenn die an der Entnahmestelle gemessene Temperatur von der am Thermostaten eingestellten Temperatur abweicht.



## Wartung (siehe Seite 64)

- Um die Leichtgängigkeit der Regeleinheit zu gewährleisten, sollte der Thermostat von Zeit zu Zeit auf ganz warm und ganz kalt gestellt werden.
- Der Thermostat ist mit Rückflussverhindern ausgestattet. Rückflussverhinderer müssen gemäß DIN EN 1717 regelmäßig in Übereinstimmung mit nationalen oder regionalen Bestimmungen (DIN 1988 einmal jährlich) auf ihre Funktion geprüft werden. Überprüfen Sie bei dieser Gelegenheit auch die Schmutzfänger, welche sich auf der BTC-Regeleinheit (A) befinden. Nach Montage der BTC-Regeleinheit (96633000) unbedingt die Auslauftemperatur überprüfen, wie unter Punkt "Einjustieren" beschrieben. Überprüfen Sie unbedingt zuvor, ob die Warmwasserversorgung eingeschaltet ist und die max. Warmwassertemperatur an der Zapfstelle anliegt.



## Maße (siehe Seite 66)



## Serviceteile (siehe Seite 68)

XXX = Farbcodierung  
 000 chrom  
 090 chrom/gold-optik  
 800 edelstahl-optik  
 820 brushed nickel  
 830 polished nickel



## Bedienung (siehe Seite 70)



## Reinigung

siehe beiliegende Broschüre.



## Prüfzeichen (siehe Seite 67)



## Montage siehe Seite 60



<b>Störung</b>	<b>Ursache</b>	<b>Abhilfe</b>
Wenig Wasser	- Versorgungsdruck nicht ausreichend	- Leitungsdruck prüfen
	- Schmutzfangsieb der Regeleinheit verschmutzt	- Schmutzfangsiebe reinigen
	- Siebdichtung der Brause verschmutzt	- Siebdichtung zwischen Brause und Schlauch reinigen
Kreuzfluss, warmes Wasser wird bei geschlossener Armatur in die Kaltwasserleitung gedrückt oder umgekehrt	- Rückflussverhinderer verschmutzt / defekt	- Rückflussverhinderer reinigen ggf. austauschen
Auslauftemperatur stimmt nicht mit der eingestellten Temperatur überein	- Thermostat wurde nicht justiert	- Thermostat justieren
	- Zu niedere Warmwassertemperatur	- Warmwassertemperatur erhöhen auf 42 °C bis 65 °C
Temperaturregelung nicht möglich	- Temperaturregeleinheit verschmutzt oder verkalkt	- Temperaturregeleinheit reinigen ggf. austauschen
	- Bei Neuinstallation Grundkörper falsch angeschlossen (Soll: kalt rechts, warm links) oder 180° verdreht eingebaut	- Funktionsblock um 180° verdreht einbauen
Druckknopf der Sicherheitsperre ohne Funktion	- Feder defekt - Druckknopf verkalkt	- Feder bzw. Druckknopf reinigen u. leicht fetten, ggf. austauschen





## Consignes de sécurité

- ⚠ Lors du montage, porter des gants de protection pour éviter toute blessure par écrasement ou coupure.
- ⚠ Le système de douche ne doit servir qu'à se laver et à assurer l'hygiène corporelle.
- ⚠ Il est interdit aux enfants ainsi qu'aux adultes ayant des insuffisances physiques, psychiques et/ou motoriques d'utiliser la douche sans surveillance. De même, il est interdit à des personnes sous influence d'alcool ou de drogues d'utiliser la douche.
- ⚠ Il est conseillé d'équilibrer les pressions de l'eau chaude et froide.

## Instructions pour le montage

La robinetterie doit être installée, rincée et contrôlée conformément aux normes valables!

## Informations techniques

Pression de service autorisée:	max. 1 MPa
Pression de service conseillée:	0,1 - 0,5MPa
Pression maximum de contrôle:	1,6MPa
(1 MPa = 10 bar = 147 PSI)	
Température d'eau chaude:	max. 80 °C
Température recommandée:	65 °C
Débit à 0,3 MPa:	environ 58 l/min
Avec dispositif anti-retour	

## Description du symbole



Ne pas utiliser de silicone contenant de l'acide acétique!

## max. Safety Function (voir page 62)

≈ 42 °C

Grâce à la fonction Safety, il est possible de pré-régler la température maximale par exemple max. 42 °C souhaitée.



## Réglage (voir page 63)

Le montage terminé, contrôler la température de l'eau puisée au mitigeur thermostatique. Un étalonnage est nécessaire si la température de l'eau mitigée mesurée au point de puisage diffère sensiblement de celle affichée sur le thermostat.



## Entretien (voir page 64)

- Pour assurer le mouvement facile de l'élément thermostatique, le thermostat devrait être placé de temps en temps en position très chaude et très froide.
- Le mitigeur thermostatique est équipé de clapets anti-retour. Les clapets anti-retour doivent être examinés régulièrement conformément à la norme EN 1717 ou conformément aux dispositions nationales ou régionales quant à leur fonction (au moins une fois par an). Contrôler par la même occasion les filtres qui se trouvent sur la cartouche thermostatique BTC (A). Après le montage de la cartouche thermostatique BTC (96633000) vérifier obligatoirement la température au point de vidange, comme il est décrit pour le réglage. Vérifier absolument auparavant si l'alimentation d'eau chaude et la température maximale se trouvent au point de vidange.



## Dimensions (voir page 66)



## Pièces détachées (voir pages 68)

XXX = Couleurs  
 000 chromé  
 090 chromé/or l'optique  
 800 stainless steel optic  
 820 brushed nickel  
 830 polished nickel



## Instructions de service (voir page 70)



## Nettoyage

voir la brochure ci-jointe.



## Classification acoustique et débit (voir page 67)









<b>Dysfonctionnement</b>	<b>Origine</b>	<b>Solution</b>
Pas assez d'eau	- Pression d'alimentation insuffisante	- Contrôler la pression
	- Filtre de l'élément thermostatique encrassé	- Nettoyer les filtres
	- Joint-filtre de douche encrassé	- Nettoyer le joint-filtre entre la douche et le flexible
Circulation opposée, l'eau chaude est comprimée dans l'arrivée d'eau froide et vice versa avec robinet fermé	- Clapet anti-retour encrassé ou défectueux	- Nettoyer le clapet anti-retour ou le changer éventuellement
La température à la sortie ne correspond pas à la température de réglage	- Le thermostat n'a pas été réglé	- Régler le thermostat
	- Température d'eau chaude trop basse, pas d'eau froide	- Augmenter la température d'eau chaude entre 42°C et 65°C
Le réglage de la température n'est pas possible	- L'élément thermostatique est encrassé ou entartré	- Nettoyer l'élément thermostatique ou le changez éventuellement
	- La pièce de base a une alimentation inversée (l'eau froide doit être à droite et l'eau chaude à gauche) ou elle est montée à l'envers	- Montez le bloc de fonction à 180°
Bouton à pression du verrouillage de sécurité défectueux	- Ressort défectueux	- Nettoyer le ressort ou bien le bouton à pression, le changer éventuellement
	- Bouton à pression entartré	





## Safety Notes

-  Gloves should be worn during installation to prevent crushing and cutting injuries.
-  The shower system may only be used for bathing, hygienic and body cleansing purposes.
-  Children as well as adults with physical, mental and/or sensoric impairments must not use this shower system without proper supervision. Persons under the influence of alcohol or drugs are prohibited from using this shower system.
-  The hot and cold supplies must be of equal pressures.

## Installation Instructions

The fitting must be installed, flushed and tested after the valid norms!

## Technical Data

Operating pressure:	max. 1 MPa
Recommended operating pressure:	0,1 - 0,5MPa
Test pressure:	1,6MPa
(1 MPa = 10 bar = 147 PSI)	
Hot water temperature:	max. 80 °C
Recommended hot water temp.:	65 °C
Rate of flow by 0,3 MPa:	approx. 58 l/min
anti-pollution function	

## Symbol description



Do not use silicone containing acetic acid!

## max. Safety Function (see page 62)

≈ 42 °C

The desired maximum temperature for example max. 42° C can be pre-set thanks to the safety function.



## Adjustment (see page 63)

After the installation, the output temperature of the thermostat must be checked. A correction is necessary if the temperature measured at the output differs from the temperature set on the thermostat.



## Maintenance (see page 64)

- To guarantee the smooth running of the thermostat, it is necessary from time to time to turn the thermostat from total hot to total cold.
- The mixer is equipped with non return valves. The non return valves must be checked regularly according to DIN EN 1717 in accordance with national or regional regulations (at least once a year). At this time, please also check the filter (A) situated on the BTC-thermoelement (96633000). After assembling the BTC-thermoelement, it is necessary to check the water temperature at the take off point as described under the headline „adjustment“. Before the adjustment, please check, if the warm water supply is activated and the maximum temperature of the warm water is available at the take off point.



## Dimensions (see page 66)



## Spare parts (see page 68)

XXX = Colors  
 000 chrome plated  
 090 chrome plated/gold plated  
 800 stainless steel optic  
 820 brushed nickel  
 830 polished nickel



## Operation (see page 70)



## Cleaning

see enclosed brochure.



## Test certificate (see page 67)



## Assembly see page 60







<b>Fault</b>	<b>Cause</b>	<b>Remedy</b>
Insufficient water	- Supply pressure inadequate	- Check water pressure (If a pump has been installed check to see if the pump is working).
	- Regulator filter dirty	- Clean filters
	- Shower filter seal dirty	- Clean filter seal between shower and hose
Crossflow, hot water being forced into cold water pipe, or vice versa, when mixer is closed	- Backflow preventers dirty or leaking	- Clean backflow preventers, exchange if necessary
Spout temperature does not correspond with temperature set	- Thermostat has not been adjusted	- Adjust thermostat
	- Hot water temperature too low	- Increase hot water temperature to 42 °C to 65 °C
Temperature regulation not possible	- Temperature regulator dirty or calcified	- Clean temperature regulator, exchange if necessary
	- For new installations: basic body incorrectly connected (should be: cold right, hot left) or installed with 180° rotation	- Install function block turned through 180°
Safety stop button not operating	- Spring defective	- Clean spring and/or button, exchange if necessary
	- Button calcified	





## **Indicazioni sulla sicurezza**

-  Durante il montaggio, per evitare ferite da schiacciamento e da taglio bisogna indossare guanti protettivi.
-  Il sistema doccia deve essere utilizzato esclusivamente per l'igiene del corpo.
-  I bambini e gli adulti affetti da menomazioni fisiche, psichiche e/o sensoriali devono utilizzare il sistema doccia solo sotto sorveglianza. Il prodotto non deve essere utilizzato da persone sotto l'effetto di droghe o alcolici.
-  **Attenzione!** Compensare le differenze di pressione tra i collegamenti dell'acqua fredda e dell'acqua calda.

## **Istruzioni per il montaggio**

La rubinetteria deve essere installata, pulita e testata secondo le istruzioni riportate!

## **Dati tecnici**

Pressione d'uso:	max. 1 MPa
Pressione d'uso consigliata:	0,1 - 0,5MPa
Pressione di prova:	1,6MPa
(1 MPa = 10 bar = 147 PSI)	
Temperatura dell'acqua calda:	max. 80 °C
Temp. dell'acqua calda consigliata:	65 °C
Potenza di erogazione a 0,3 MPa:	circa 58 l/min
Sicurezza antiriflusso	

## **Descrizione simbolo**



Non utilizzare silicone contenente acido acetico!

## **max. Safety Function** (vedi pagg. 62) **≈ 42 °C**

Grazie alla funzione antiscottature Safety la temperatura massima per esempio max. 42° C desiderata è facilmente regolabile.



## **Taratura** (vedi pagg. 63)

Effettuata l'installazione del miscelatore termostatico bisogna controllare la temperatura di uscita. La taratura è necessaria quando la temperatura dell'acqua misurata sul punto di prelievo non corrisponde a quella fissata sul termostato.



## **Manutenzione** (vedi pagg. 64)

- Per garantire la scorrevolezza dell'elemento di regolazione, di tanto in tanto si dovrebbe regolare il termostatico passando da tutto caldo a tutto freddo.
- Il miscelatore termostatico è dotato di una valvola antiritorno. La valvola di non ritorno deve essere controllata regolarmente come da DIN EN 1717, secondo le normative nazionali e regionali (almeno una volta all'anno). In tale occasione controllate anche i filtri che si trovano sulla cartuccia termostatica BTC (A). Dopo aver montato la cartuccia termostatica BTC (96633000), è necessario controllare la temperatura di erogazione come descritto nel paragrafo "Taratura". Prima controllate assolutamente se l'alimentazione di acqua calda funziona e che la temperatura massima non superi i valori consigliati.



## **Ingombri** (vedi pagg. 66)



## **Parti di ricambio** (vedi pagg. 68)

XXX = Trattamento  
 000 cromo  
 090 cromo/dorato ottica  
 800 acciaio inox acciaio  
 820 brushed nickel  
 830 polished nickel



## **Procedura** (vedi pagg. 70)



## **Pulitura**

vedi il prospetto accluso.



## **Segno di verifica** (vedi pagg. 67)











<b>Problema</b>	<b>Possibile causa</b>	<b>Rimedio</b>
Scarsità d'acqua	- Pressione di erogazione insufficiente	- Provare la pressione di erogazione
	- Filtro dell'unità di regolazione sporco	- Pulire il filtro
	- Guarnizione del filtro della doccia sporca	- Pulire la guarnizione del filtro tra doccia e flessibile
Flusso incrociato; l'acqua calda viene spinta nella tubatura acqua fredda a rubinetteria chiusa o viceversa	- Antiriflusso sporco o non ermetico	- Pulire o sostituire l'antiriflusso
La temperatura di erogazione diversa da quella impostata	- Il termostatico non è stato regolato	- Regolare il termostatico
	- Temperatura dell'acqua calda	- Aumentare la temperatura acqua calda tra 42 °C e 65 °C
Impossibile la regolazione temperatura	- Elemento termostatico sporco o con depositi calcarei	- Pulire o sostituire l'unità di regolazione
	- In caso di nuova installazione - collegato male il termostatico (deve essere: acqua fredda a destra e calda a sinistra) o installato ruotato di 180°	- Ruotare di 180° l'unità di regolazione
Tasto antiscottatura non funzionante	- Molla difettosa - Tasto con depositi calcarei	- Pulire o sostituire la molla o il tasto





## Indicaciones de seguridad

-  Durante el montaje deben utilizarse guantes para evitar heridas por aplastamiento o corte.
-  La grifería solo debe ser utilizada para fines de baño, higiene y limpieza corporal.
-  Niños, así como adultos con limitaciones corporales, mentales y/o sensoriales no deben utilizar el sistema de duchas sin vigilancia. Personas que se encuentran bajo el efecto de alcohol o drogas, no deben utilizar el sistema de duchas.
-  Grandes diferencias de presión en servicio entre agua fría y agua caliente deben equilibrarse.

## Indicaciones para el montaje

El grifo tiene que ser instalado, probado y testado, según las normas en vigor.

## Datos técnicos

Presión en servicio:	max. 1 MPa
Presión recomendada en servicio:	0,1 - 0,5MPa
Presión de prueba:	1,6MPa
(1 MPa = 10 bar = 147 PSI)	
Temperatura del agua caliente:	max. 80 °C
Temp. recomendada del agua caliente:	65 °C
Caudal a 0,3 MPa:	aprox. 58 l/min
Seguro contra el retorno	

## Descripción de símbolos



No utilizar silicona que contiene ácido acético!

## max. Safety Function (ver página 62)

≈ 42 °C

Gracias al tope de temperatura se puede graduar la temperatura máxima por ejemplo max. 42° C.



## Puesta a punto (ver página 63)

Después del montaje deberá comprobarse la temperatura del agua del termostato, en la salida del caño. Una corrección se efectuará siempre y cuando la temperatura del agua tomada a la salida del caño, no corresponda con la indicada en el volante del termostato.



## Mantenimiento (ver página 64)

- Para garantizar el funcionamiento duradero del termostato, el mando del mismo debería girarse de vez en cuando del extremo frío al extremo caliente.
- El termostato está equipado con válvula, la cual evita el retorno del agua a la tubería. Las válvulas anti-retorno tienen que ser controladas regularmente según la norma DIN EN 1717, en acuerdo con las regulaciones nacionales o regionales (una vez al año, por lo menos). Conviene comprobar al mismo tiempo el filtro del termoelemento (A). Después de poner el termoelemento se ha de ajustar el termoelemento a la temperatura (ver "Puesta a punto"). Asegúrese de que el agua caliente esté conectada.



## Dimensiones (ver página 66)



## Repuestos (ver página 68)

XXX = Acabados  
 000 cromado  
 090 cromo/oro óptica  
 800 acero especial  
 820 brushed nickel  
 830 polished nickel



## Manejo (ver página 70)



## Limpiar

ver el folleto adjunto.



**Marca de verificación** (ver página 67)



## Montaje ver página 60



<b>Problema</b>	<b>Causa</b>	<b>Solución</b>
Sale poca agua	- presión insuficiente	- comprobar presión
	- filtro del termoelemento sucio	- limpiar filtro
	- filtro de la ducha sucio	- limpiar/cambiar filtros entre flexo y ducha
Flujo de agua cruzada agua caliente entra en la tubería del agua fría o al revés	- válvula antirretorno sucia o pierde	- limpiar / cambiar válvula
Temperatura del agua no corresponde a lo marcado	- termostato no ha sido ajustado	- ajustar termostato
	- temperatura del agua demasiado baja no hay	- aumentar temperatura del agua caliente a 42° - 65° C.
No es posible regular la temperatura	- termoelemento sucio/lleño de cal	- limpiar / cambiar termoelemento
	- cuerpo empotrado mal montado (debe estar: frío = derecha) o instalado girado en 180°	- girar embellecedor en 180°
Botón de tope no funciona	- muelle defecto	- Limpiar y aplicar una fina capa de grasa en el muelle y el pulsador
	- botón lleño de cal	





## Veiligheidsinstructies

- ⚠ Bij de montage moeten ter voorkoming van knel- en snijwonden handschoenen worden gedragen.
- ⚠ Het douchesysteem mag alleen voor het wassen, hygiënische doeleinden en voor de lichaamreiniging worden gebruikt.
- ⚠ Kinderen en volwassenen met lichamelijke, geestelijke en/of sensorische beperkingen mogen het douchesysteem niet zonder toezicht gebruiken. Personen onder invloed van alcohol of drugs mogen het douchesysteem niet gebruiken.
- ⚠ Grote drukverschillen tussen de kouden warm wateraansluitingen dienen vermeden te worden.

## Montage-instructies

Leidingen doorspoelen volgens Norm. De mengkraan vervolgens monteren en controleren!

## Technische gegevens

Werkdruk: max.	max. 1 MPa
Aanbevolen werkdruk:	0,1 - 0,5MPa
Getest bij:	1,6MPa
(1 MPa = 10 bar = 147 PSI)	
Temperatuur warm water:	max. 80 °C
Aanbevolen warm water temp.:	65 °C
Doorvoercapaciteit bij 0,3 MPa:	ca. 58 l/min
Beveiligd tegen terugstromen	

## Symboolbeschrijving



Gebruik geen zuurhoudende silicone!

## max. Safety Function (zie blz. 62)

≈ 42 °C

Dankzij de Safety Function kan de gewenste maximale temperatuur van bijv. max. 42° C van te voren worden ingesteld.



## Correctie (zie blz. 63)

Na montage dient de uitstroomtemperatuur van de thermostaat gecontroleerd te worden. Een correctie is noodzakelijk als de aan het tappunt gemeten temperatuur afwijkt van de op de thermostaat ingestelde temperatuur.



## Onderhoud (zie blz. 64)

- Om het soepel lopen van de regelaar te garanderen moet de thermostaat van tijd tot tijd op heel koud en heel warm worden ingesteld.
- De thermostaat is voorzien van terugslagkleppen. Keerklappen moeten volgens DIN EN 1717 regelmatig en volgens plaatselijk geldende eisen op het functioneren gecontroleerd worden. (Tenminste een keer per jaar). Tevens moeten de zeefjes op het thermoelement worden gecontroleerd (A). Na montage van het BTC thermo-element moet de uitstroomtemperatuur gecontroleerd worden. Zie hiervoor 'correctie'. Controleer vooraf of de warmwater voorziening functioneert en wat de maximale watertemperatuur bij het tappunt is.



## Maten (zie blz. 66)



## Service onderdelen (zie blz. 68)

XXX = Kleuren  
 000 verchromd  
 090 chroom/verguld-look  
 800 RVS-look  
 820 brushed nickel  
 830 polished nickel



## Bediening (zie blz. 70)



## Reinigen

zie bijgevoegde brochure.



## Keurmerk (zie blz. 67)



## Montage zie blz. 60







Storing	Oorzaak	Oplossing
Weinig water	- Druk te laag	- Druk controleren
	- Vuilzeef van thermo-element verstopt	- Vuilzeef reinigen
	- Zeefdichting handdouche verstopt	- Zeefdichting handdouche reinigen
Kruisstroom, warm water stroomt in gesloten toestand in koud water leiding of omgekeerd	- Terugslagkleppen vervuild of defect	- Terugslagkleppen reinigen dan wel uitwisselen
Uitstroomtemperatuur komt niet met ingestelde temperatuur overeen	- Thermostaat niet ingesteld	- Thermostaat instellen
	- Temperatuur van warm water te laag	- Warmwater toevoer verhogen min. 42°C naar 65°C
Temperatuur niet regelbaar	- Thermo-element vervuild of verkalkt	- Thermo-element reinigen dan wel uitwisselen
	- Bij nieuwe installaties: basisgarnituur verkeerd aangesloten (moet zijn koud rechts en warm links) of 180° gedraaid gemonteerd	- Functieblok 180° draaien
Safety Stop knop op thermostaatgreep functioneert niet	- Veer defect	- Veer en/of drukknop reinigen dan wel uitwisselen
	- Drukknop verkalkt	





## Sikkerhedsanvisninger

-  Ved monteringen skal der bruges handsker for at undgå kvæstelser og snitsår.
-  Brusersystemet må kun bruges til bade-, hygiejne og rengøringsformål.
-  Børn som også voksne med fysiske, mentale og / eller sensoriske begrænsninger må ikke bruge brusersystemet uden opsyn. Personer som er under indflydelse af alkohol eller narkotika må ikke bruge brusersystemet.
-  Større trykforskelle mellem koldt og varmt vand bør udjævnes.

## Monteringsanvisninger

Ifølge gældende regler, skal armaturet monteres, skylles igennem og afprøves.

## Tekniske data

Driftstryk:	max. 1 MPa
Anbefalet driftstryk:	0,1 - 0,5MPa
Prøvetryk:	1,6MPa
(1 MPa = 10 bar = 147 PSI)	
Varmtvandstemperatur:	max. 80 °C
Anbefalet varmtvandstemperatur:	65 °C
Gennemstrømningsydelse ved 0,3 MPa:	ca. 58 l/min
Med indbygget kontraventil	

## Symbolbeskrivelse



Der må ikke benyttes eddikesyreholdig silikone!

## max. Safety Function (se s. 62)

≈ 42 °C

Takket være Safety varmtvandsbegrænsningen kan maksimaltemperaturen forudindstilles eksempel max. 42° C.



## Justering (zie blz. 63)

Efter monteringen skal termostatsens udløbstemperatur kontrolleres. Såfremt den målte vandtemperatur afviger fra den på termostaten viste forindstilling er en korrigerig af skalagrebet nødvendig.



## Service (se s. 64)

- For at sikre optimal funktion af termostaten, bør termostaten fra tid til anden motioneres (stilles skiftevis helt varm og helt kold).
- Termostaten er forsynet med kontraventil . Ifølge DIN EN 1717 skal gennemstrømningsbegrænsere i overensstemmelse med nationale regler afprøves regelmæssigt (mindst en gang om året). lejlighed bør smudsfangsien efterses – den befinder sig på termostatelementet (A). Efter montering af termostatelementet (96633000) er det vigtigt, at udløbstemperaturen kontrolleres (se under punktet "Justering"). Kontrolér at varmtvandsforsyningen er tilsluttet, og at temperaturen ikke overstiger max. temperatur.
- OBS! Det er vigtig at motionere termostaten jævnligt ved at dreje termostatgrebet skiftevis på kold og varm.



## Målene (se s. 66)



## Reserve dele (se s. 68)

- XXX = Overflade
- 000 Krom
- 090 Krom/guld optic
- 800 Stainless steel optic
- 820 Brushed nickel
- 830 Polished nickel



## Brugsanvisning (se s. 70)



## Rengøring

se venligst den vedlagte brochure.



## Godkendelse (se s. 67)



## Montering se s. 60



Fejl	Årsag	Hjælp
For lidt vand	- Forsyningstrykket er ikke højt nok	- Afprøv forsyningstrykket
	- Smudsfang sien er snavset	- Rengør smudsfang sien
	- Sien mellem bruser og slange er snavset	- Rengør sien mellem bruser og slange
Kryds-flow, varmt vand i koldt vandsledning og omvendt	- Kontraventilen er snavset eller utæt.	- Rengør kontraventilen eller udskift den evt.
Udløbstemperaturen stemmer ikke overens med den indstillede temperatur	- Termostaten er ikke justeret	- Juster termostaten!
	- For lav varmtvands-temperatur	- Forhøj varmtvands-temperaturen fra 42°C til 65°C
Temperaturregulering ikke mulig	- Termostatelementet er snavset eller tilkalket	- Rengør termostat-elementet eller udskift det evt.
	- Ved ny-installation er vandtilslutningen forbyttet (skal være koldt til højre - varmt til venstre eller også er grundkroppen drejet 180°)	- Vend indbygningsdelen 180°
Sikkerhedsspærren er ude af funktion	- Defekt fjeder - Trykknappen tilkalket	- Rengør fjeder og tryknap eller udskift delene





## Avisos de segurança

- ⚠ Durante a montagem devem ser utilizadas luvas de protecção, de modo a evitar ferimentos resultantes de entalamentos e de cortes.
- ⚠ O sistema de duche só pode ser utilizado para fins de higiene pessoal.
- ⚠ Crianças e adultos com deficiências motoras, mentais e/ou sensoriais não podem utilizar o sistema de duche sem monitorização. Pessoas que estejam sob a influência de álcool ou drogas não podem utilizar o sistema de duche.
- ⚠ Grandes diferenças entre as pressões das águas quente e fria devem ser compensadas.

## Avisos de montagem

A misturadora deve ser instalada, purgada e testada de acordo com as normas em vigor!

## Dados Técnicos

Pressão de funcionamento:	max. 1 MPa
Pressão de func. recomendada:	0,1 - 0,5MPa
Pressão testada:	1,6MPa
(1 MPa = 10 bar = 147 PSI)	
Temperatura da água quente:	max. 80 °C
Temp. água quente recomendada:	65 °C
Caudal o 0,3 MPa:	ca. 58 l/min
Função anti-retorno e anti-vácuo	

## Descrição do símbolo



Não utilizar silicone que contenha ácido acético!

## max. Safety Function (ver página 62)

≈ 42 °C

Graças à função de segurança pode-se regular a temperatura máxima por exemplo max. 42°C.



## Afinação (ver página 63)

É necessária correcção se a temperatura medida no ponto de saída diferir da temperatura marcada na escala.



## Manutenção (ver página 64)

- Para garantir um funcionamento suave do elemento termostático é necessário de vez em quando rodar totalmente o manípulo da termostática da posição quente para a fria.
- A misturadora está equipada com válvulas anti-retorno. As válvulas anti-retorno devem ser verificadas regularmente de acordo com a DIN EN 1717 segundo os regulamentos nacionais ou regionais (pelo menos uma vez por ano). Verifique nesta ocasião também a sujidade e o estado do cartucho (A). Depois da montagem do cartucho (96633000) testar a temperatura da água, como descrito no ponto "Afinação". Verifique previamente se o abastecimento de água quente está ligado e se está no máximo da temperatura.



## Medidas (ver página 66)



## Peças de substituição (ver página 68)

XXX = Acabamentos  
 000 cromado  
 090 cromado/ouro ótica  
 800 aço imaculado ótica  
 820 brushed nickel  
 830 polished nickel



## Funcionamento (ver página 70)



## Limpeza

consultar a seguinte brochura.



## Marca de controlo (ver página 67)











<b>Falha</b>	<b>Causa</b>	<b>Solução</b>
Água insuficiente	- Pressão não adequada	- Verificar a pressão da água
	- Filtro do regulador sujo	- Limpar os filtros
	- Filtro do vedante do chuveiro sujo	- Limpar o filtro entre o chuveiro e o tubo flexível
Fluxos cruzados, água quente a ser forçada a entrar no tubo da água fria, ou vice-versa, quando a misturadora está fechada.	- Válvula anti-retorno suja ou com fugas	- Limpar a válvula antiretorno, substitua se necessário
A temperatura da água não corresponde à temperatura seleccionada	- A misturadora termos tática não foi ajustada	- Ajustar a misturadora termostática
	- Temperatura da água quente muito baixa	- Aumentar a temperatura da água quente para 42° C a 65° C.
Não é possível regular a temperatura	- Regulador da temperatura sujo ou calcificado	- Limpar o regulador de temperatura, substitua se necessário
	- Para novas instalações: Corpo instalado incorrectamente (deve ser: fria direita, quente esquerda) ou instalado com uma rotação de 180°	- Instalar o corpo virado 180°
Botão de segurança não funciona	- Mola defeituosa	- Limpar a mola e/ou o botão, substitua se necessário
	- Botão calcificado	





## Wskazówki bezpieczeństwa

-  Aby uniknąć zranień, takich jak zgniecenia czy przecięcia, podczas montażu należy nosić rękawice.
-  Prysznica może być używany tylko do kąpieli, higieny i czyszczenia ciała.
-  Zarówno dzieci, jak i dorośli z fizycznymi, psychicznymi i/lub sensorycznymi ograniczeniami nie mogą korzystać z prysznica bez opieki. Osoby znajdujące się pod wpływem alkoholu lub narkotyków nie mogą korzystać z prysznica.
-  Znaczne różnice ciśnień na dopływach ciepłej i zimnej wody muszą zostać wyrównane.

## Wskazówki montażowe

Armatura musi być zamontowana, przepłukana i wypróbowana według obowiązujących norm!

## Dane techniczne

Ciśnienie robocze:	maks. 1 MPa
Zalecane ciśnienie robocze:	0,1 - 0,5MPa
Ciśnienie próbne:	1,6MPa
(1 MPa = 10 bary = 147 PSI)	
Temperatura wody gorącej:	maks. 80 °C
Zalecana temperatura wody gorącej:	65 °C
Wydajność przepływu przy 0,3 MPa:	ok. 58 l/min
Samoistnie zabezpieczony przed przepływem zwrotnym	

## Opis symbolu



Nie stosować silikonów zawierających kwas octowy!

## max. Safety Function (patrz strona 62)

≈ 42 °C

Dzięki funkcji zabezpieczającej można przestawić żądaną maksymalną temperaturę np. na maks. 42°C.



## Regulacja (patrz strona 63)

Po ukończeniu montażu należy sprawdzić temperaturę ciepłej wody na wylocie z termostatu. Korekta będzie konieczna wtedy, gdy zmierzona temperatura na wylocie różni się od temperatury nastawionej na termostacie.



## Konserwacja (patrz strona 64)

- Aby zachować łatwość obsługi termostatu, od czasu do czasu należy go przekręcić na całkiem zimną i na całkiem ciepłą wodę.
- Termostat wyposażony został w zabezpieczenia przed przepływem zwrotnym. Działanie zabezpieczeń przed przepływem zwrotnym, zgodnie z normą DIN EN 1717 i miejscowymi przepisami, musi być kontrolowane (DIN 1988, raz w roku). Przy okazji należy także sprawdzić łapacze zanieczyszczeń, które znajdują się na termostacie BTC (A) Po montażu termostatu BTC (96633000) należy koniecznie sprawdzić temperaturę wypływającej wody w sposób opisany w punkcie "Regulacja". Przedtem należy koniecznie sprawdzić czy włączone jest zasilanie ciepłej wody i czy w miejscu poboru jest maks. temperatura ciepłej wody.



## Wymiary (patrz strona 66)



## Części serwisowe (patrz strona 68)

XXX = kody wykończenia powierzchni  
 000 chrom  
 090 chrom/złoty szlachetna  
 800 stal szlachetna  
 820 nikiel szorowany  
 830 nikiel polerowany



## Obsługa (patrz strona 70)



## Czyszczenie

patrz dołączona broszura.



## Znak jakości (patrz strona 67)



**Montaż patrz strona 60**







<b>Usterka</b>	<b>Przyczyna</b>	<b>Pomoc</b>
Mała ilość wody	- Zbyt niskie ciśnienie zasilające	- Sprawdzić ciśnienie w instalacji
	- Zabrudzone sitko przy wkładzie termostatycznym	- Wyczyścić sitka
	- Zabrudzona uszczelka z sitkiem w prysznicu	- Oczyszczyć uszczelkę z sitkiem pomiędzy prysznicem a węzłem
Przepływ krzyżowy, woda ciepła przy zamkniętej armaturze wpływa do przewodu wody zimnej lub odwrotnie	- Zabrudzone / uszkodzone zabezpieczenie przed przepływem zwrotnym	- Wyczyścić wzgl. wymienić zabezpieczenie przed przepływem zwrotnym
Temperatura wody nie zgadza się z ustawioną wartością	- Termostat nie został wyregulowany	- Przeprowadzić regulację termostatu
	- Za niska temperatura ciepłej wody	- Podwyższyć temperaturę wody ciepłej na 42°C do 65°C
Brak możliwości regulacji temperatury	- Zabrudzony lub zakamieniony termostat	- Wyczyścić lub wymienić termostat
	- Przy nowej instalacji niewłaściwie podłączony korpus (powinno być: zimna po prawej, ciepła po lewej) albo zamontowano z przekręceniem o 180°.	- Blok funkcyjny obrócić o 180°
Złe funkcjonowanie przycisku zabezpieczającego	- Uszkodzona sprężynka - przycisk zakamieniony	- Wyczyścić wzgl. wymienić sprężynkę lub przycisk i lekko nasmarować





## **Bezpečnostní pokyny**

-  Pro zabránění řezným zraněním a pohmožděninám je nutné při montáži nosit rukavice.
-  Produkt smí být používán pouze ke koupání a za účelem tělesné hygieny.
-  Děti a dospělí osoby s tělesným, duševním a / nebo smyslovým postižením nesmí produkt používat bez dozoru. Osoby pod vlivem alkoholu nebo drog nesmí produkt používat.
-  Je nutné vyrovnat velké rozdíly tlaku mezi přípoji studené a teplé vody.

## **Pokyny k montáži**

Armatura se musí montovat, proplachovat a testovat podle platných norem!

## **Technické údaje**

Provozní tlak:	max. 1 MPa
Doporučený provozní tlak:	0,1 – 0,5MPa
Zkušební tlak:	1,6MPa
(1 MPa = 10 bar = 147 PSI)	
Teplota horké vody:	max. 80 °C
Doporučená teplota horké vody:	65 °C
Průtokové množství při 0,3 MPa:	cca 58 l/min
Vlastní jištění proti zpětnému nasátí.	

## **Popis symbolů**



Nepoužívat silikon s obsahem kyseliny octové!

## **max. Safety Function** (viz strana 62) **≈ 42 °C**

Díky Safety Function je možné předem nastavit nejvyšší požadovanou teplotu, např. max. 42°C.



## **Nastavení** (viz strana 63)

Po ukončení montáže se musí zkontrolovat teplota vody vytékající z termostatu. Pokud se teplota změnená v místě odběru liší od teploty nastavené na termostatu, je nutné provést korekci.



## **Údržba** (viz strana 64)

- Aby byl zajištěn lehký chod regulační jednotky, měl by se termostat čas od času nastavit na úplně horkou a úplně studenou vodu.
- Termostat je vybaven omezovačem zpětného toku. U zpětných ventilů se musí podle DIN EN 1717 v souladu s národními nebo regionálními předpisy testovat jejich funkčnost (alespoň jednou ročně). Zkontrolujte při této příležitosti také lapače nečistot, které se nacházejí na BTC regulační jednotce (A). Po montáži BTC regulační jednotky (96633000) zkontrolujte bezpodmínečně teplotu na výtoku, jak je popsáno v bodu „Nastavení“. Předtím rozhodně zkontrolujte, jestli je zapnuto zásobování teplou vodou a jestli je v místě odběru voda s maximální teplotou k dispozici.



## **Rozměry** (viz strana 66)



## **Servisní díly** (viz strana 68)

XXX = kód povrchové úpravy  
 000 chrom  
 090 chrom/zlato ocel  
 800 nerezová ocel  
 820 brushed nickel  
 830 polished nickel



## **Ovládání** (viz strana 70)



## **Čištění**

viz příložená brožura.



## **Zkušební značka** (viz strana 67)





<b>Porucha</b>	<b>Příčina</b>	<b>Odstranění</b>
Málo vody	- Nízký tlak v přívodu. - Zanesený lapač nečistot v regulační jednotce - Sítko v těsnění u sprchy zanesené	- Zkontrolovat tlak v potrubí - Vyčistit sítko lapačů nečistot - Vyčistit sítko v těsnění mezi sprchou a hadicí
Křížení toků, teplá voda se při zavřené armatuře tlačí do přívodu studené vody nebo naopak	- Znečištěný nebo netěsný zpětný ventil	- Zpětný ventil vyčistit, případně vyměnit
Teplota u výtoku nesouhlasí s nastavenou teplotou	- Teplota u výtoku nesouhlasí s nastavenou teplotou - nízká teplota teplé vody	- Nastavit termostat - Teplotu horké vody zvýšit na 42°C až 65°C
Nelze regulovat teplotu	- Regulační jednotka teploty znečištěná nebo zanesená vodním kamenem - U nové instalace: obráceně připojené základní těleso (má být studená vpravo, teplá vlevo) nebo zabudované otočené o 180°	- Regulační jednotku teploty vyčistit, případně vyměnit - Funkční blok zabudovat otočený o 180°
Tlačítko bezpečnostní pojistky je nefunkční	- Vadná pružina - Tlačítko zanesené vodním kamenem	- Pružinu nebo tlačítko očistit a lehce potřít tukem, případně vyměnit





## Bezpečnostné pokyny

- ⚠ Pri montáži musíte nosiť rukavice, aby ste predišli pomliaždeninám a rezným poraneniam.
- ⚠ Produkt sa smie používať len na kúpanie a telesnú hygienu.
- ⚠ Produkt nesmú bez dozoru používať deti, ako aj dospelé osoby s telesným, duševným a/alebo zmyslovým postihnutím. Produkt nesmú používať ani osoby, ktoré sú pod vplyvom alkoholu alebo drog.
- ⚠ Veľké rozdiely v tlaku medzi prípojkami studenej a teplej vody musia byť vyrovnané.

## Pokyny pre montáž

Batéria sa musí montovať, preplachovať a testovať podľa platných noriem!

## Technické údaje

Prevádzkový tlak:	max. 1 MPa
Doporučený prevádzkový tlak:	0,1 – 0,5MPa
Skúšobný tlak:	1,6MPa
(1 MPa = 10 bar = 147 PSI)	
Teplota teplej vody:	max. 80 °C
Doporučená teplota teplej vody:	65 °C
Prietokové množstvo pri 0,3 MPa:	asi 58 l/min
Vlastná poisťka proti spätnému nasatiu.	

## Popis symbolov



Nepoužívať silikón s obsahom kyseliny octovej!

## max. Safety Function (viď strana 62) ≈ 42 °C

Vďaka Safety Function je možné vopred nastaviť najvyššiu požadovanú teplotu, napr. max. 42°C.



## Nastavenie (viď strana 63)

Po ukončení montáže sa musí skontrolovať teplota vody vytekajúcej z termostatu. Pokiaľ sa teplota nameraná na mieste odberu líši od teploty nastavenej na termostate, je nutné vykonať korekciu.



## Údržba (viď strana 64)

- Aby bol zaistený ľahký chod regulačnej jednotky, mal by sa termostat z času čas nastavíť na maximálne horúcu a maximálne studenú vodu.
- Batéria je vybavená spätným uzáverom. Pri spätných ventiloch sa musí podľa DIN EN 1717 v súlade s národnými alebo regionálnymi predpismi testovať ich funkčnosť (aspoň raz ročne). Skontrolujte pri tejto príležitosti aj lapače nečistôt, ktoré sa nachádzajú na BTC regulačnej jednotke (A). Po montáži BTC regulačnej jednotky (96633000) skontrolujte bezpodmienečne teplotu na výtok, ako je popísané v bode „Nastavenie“. Predtým rozhodne skontrolujte, či je zapnuté zásobovanie teplou vodou a či je v mieste odberu voda s maximálnou teplotou k dispozícii.



## Rozmery (viď strana 66)



## Servisné diely (viď strana 68)

XXX = kód povrchovej úpravy  
 000 chróm  
 090 chróm/zlato ocel  
 800 nerezova ocel  
 820 brushed nickel  
 830 polished nickel



## Obsluha (viď strana 70)

## Čistenie

nájdete v priloženej brožúre.

**Osvedčenie o skúške** (viď strana 67)





Porucha	Príčina	Pomoc
Málo vody	- Nízky tlak v prívode.	- Skontrolovať tlak v potrubí
	- Zanesený lapač nečistôt v regulačnej jednotke	- Vyčistiť sitká lapačov nečistôt
	- Sitko v tesnení sprchy je znečistené	- Vyčistiť sitko tesnení medzi sprchou a hadicou
Kríženie tokov, teplá voda sa pri uzavretej armatúre tlačí do prívodu studenej alebo naopak	- Znečistený alebo netesný spätný ventil	- Spätný ventil vyčistiť, prípadne vymeniť
Teplota na výtoku nesúhlasí s nastavenou teplotou	- Nebol nastavený termostat	- Nastavíť termostat
	- Nízka teplota teplej vody	- Teplotu teplej vody zvýšiť na 42°C až 65°C
Nie je možné regulovať teplotu	- Regulačná jednotka teploty znečistená alebo zanesená vodným kameňom.	- Regulačnú jednotku teploty vyčistiť, prípadne vymeniť
	- Pri novej inštalácii: naopak pripojené základné teleso (má byť studená vpravo, teplá vľavo) alebo zabudované otočené o 180°	- Funkčný blok zabudovať o 180°
Tlačidlo bezpečnostnej poisťky je nefunkčné	- Vadná pružina - Tlačidlo zanesené vodným kameňom	- Pružinu alebo tlačidlo vyčistiť a zľahka potrieť tukom, prípadne vymeniť





## 安全技巧

- △ 装配时为避免挤压和切割受伤，必须戴上手套。
- △ 淋浴系统只允许作为洗浴、卫生和洁身之用。
- △ 不得让儿童和肢体、精神和/或意识有障碍的成人在不受监管的情况下使用淋浴系统。受酒精或毒品影响的人员不得使用淋浴系统。
- △ 冷热水管间过大的压力差必须予以平衡。

## 安装提示

必须按照现行的规定安装，冲洗和测试产品！

## 技术参数

工作压力:	最大 1 MPa
推荐工作压力:	0,1 0,5MPa
测试压强:	1,6MPa
(1 MPa = 10 bar = 147 PSI)	
热水温度:	最大 80° C
推荐热水温度:	65° C
流量 钟0,3 MPa:	大约 58 升/分钟
自动防止回流	



## 保养 (参见第 64 页)

- 为了保证恒温器的稳定运转，请务必定期从最热到最冷转动调温器。
- 此恒温龙头带有单向阀。单向阀必须在符合国家或当地的法律的情况下按照DIN EN 1717定期检查（至少一年一次）。在此情况下，请同时检查BTC恒温阀芯（A）上的过滤网。在安装BTC恒温阀芯（A）后，请务必在拿掉“调节器”的情况下检测水温。在调节时，请检查热水供水是否正常及热水能提供的最高温度。

## 符号说明



请勿使用含有乙酸的硅！

**max.**  
**≈ 42° C**

### 安全功能 (参见第 62 页)

恒温阀芯的安全功能可以预先设定所希望的最高出水温度，例如最高温度为42°C



### 校准 (参见第 63 页)

安装完成后必须检查调温器的出水温度。如在取水处测量所得的温度与调温器上设定的温度有偏差，那么必须进行调整。



## 大小 (参见第 66 页)



### 备用零件 (参见第 68 页)

XXX = 颜色代码

- 000 镀铬
- 090 镀铬/黑色
- 800 不锈钢表面
- 820 镍拉丝
- 830 镍抛光



### 操作 (参见第 70 页)



### 清洗

附有小手册  
检验标记 (参见第 67 页)



## 安装 参见第 60 页





问题	原因	补救
龙头出水量小	-水压不足	-检查总水压
	-调压器过滤网脏污	-清洗过滤网
	-花洒滤网有垃圾堵塞	-清洗花洒和软管间的过滤密封件
串水，在龙头关闭的状态下，热水被强迫流入冷水管路，或者相反。	-单向阀有垃圾堵塞或漏水	-清洗单向阀，如有必要则更换新的
龙头出水温度和温度设定的不符	-恒温器未被调节	-调节恒温器
	-热水温度过低	-将热水温度从42°C升高到65°C
水温无法调节	-温度调节器脏污或结垢	-清洁温度调节器，视需要更换
	-对于新的安装：基体连接不正确（可能是：右冷，左热）或者安装时旋转180°	-安装功能块时，旋转180°
安全停止按钮不工作	-弹簧损坏	-清洁弹簧和/或按钮，并视需要更换
	-按钮僵化	





## Указания по технике безопасности

-  Во время монтажа следует надеть перчатки во избежание прищемления и порезов.
-  Изделие разрешается использовать только в гигиенических целях: для принятия ванны и личной гигиены.
-  Дети, а также взрослые с физическими, умственными и/или сенсорными недостатками должны пользоваться изделием только под присмотром. Запрещается пользоваться изделием в состоянии алкогольного или наркотического опьянения.
-  донного клапа. Перед установкой смесителя необходимо регулировочными кранами выровнять давление холодной и горячей воды при помощи вентилей регулирующих подачу воды в квартиру.

## Указания по монтажу

Смеситель должен быть смонтирован по действующим нормам и в соответствии с настоящей инструкцией, проверен на герметичность и безупречность работы

## Технические данные

Рабочее давление:	не более. 1 МПа
Рекомендуемое рабочее давление:	0,1 – 0,5 МПа
Давление:	1,6 МПа
(1 МПа = 10 bar = 147 PSI)	
Температура горячей воды:	не более. 80 °С
Рекомендуемая темп. гор. воды:	65 °С
Расход при 0,3 МПа:	ок. 58 л/мин
укомплектован клапаном обратного тока воды	

## Описание символов



Не применяйте силикон, содержащий уксусную кислоту.

## max. Safety Function (см. стр. 62)

≈ 42 °С

С помощью функции Safety Function может быть задана максимальная температура воды, например 42 °С.



## Настройка (см. стр. 63)

После монтажа следует проверить температуру на выходе из термостата. Скорректируйте температуру воды, если она отличается от установленной на термостате.



## Техническое обслуживание

(см. стр. 64)

- Для гарантии плавного изменения температуры и долгого срока службы необходимо периодически поворачивать ручку регулировки температуры из положение максимально горячая в положение максимально холодная вода.
- Термостат оснащен клапанами обратного течения. Защита обратного тока должна регулярно проверяться (минимум один раз в год) по стандарту DIN EN 1717 или в соответствии с национальными или региональными нормативами Состояние фильтра (A), установленного на термостатическим картридже. После замены термoeлементa необходимо проверить работу смесителя и, проверив условия водоснабжения, произвести настройку (см. выше), изменяя положение стопорного кольца. Для гарантии плавного изменения температуры и долгого срока службы необходимо периодически поворачивать ручку регулировки температуры из положение максимально горячая в положение максимально холодная вода.



## Размеры (см. стр. 66)



## Комплект (см. стр. 68)

XXX = Код цвета поверхности  
 000 хром  
 090 хром/глянцевое золото  
 800 сталь  
 820 brushed nickel  
 830 polished nickel



## Эксплуатация (см. стр. 70)



## Очистка

см прилагаемая брошюра



**Знак технического контроля**  
 (см. стр. 67)



## Монтаж см. стр. 60







Неисправность	Причина	Устранение неисправности
недостаточный давление (если устан напор воды)	- Проблемы водоснабжения	- Проверить овлен насос проверить работу насоса
	- Фильтр термоэлемента загрязнен	- Очистить фильтр
	- Фильтр душа загрязнен	- Очистить фильтр
Подмес воды, в закрытом положене горячая вода стремится в подводку холодной воды или наоборот	- Клапан обратного тока воды загрязнен или неисправен	- Очистить кланан или заменить при необходимости
Температура смешанной воды не соответствует шкале	- Термостат не настроен	- Настроить термостат
	- Температура горячей воды слишком низкая	- Поднять температуру горячей воды с 42 град.С до 65 град.С
Регулировка температура не производится	- Термоэлемент загрязнен или покрыт известью	- Очистить термоэлемент при необходимости заменить термоэлемент
	- для вновь установленного изделия: ошибка установки, холод ная вода подводится справа горячая слева, или установлено с 180 град поворотом.	- повернуть внутренний блок
Красная кнопка защиты от ожога не работает	- Износ пружины кнопки - Заизвесткованность кнопки	- Очистите пружину или кнопку и слегка смажьте, при необходимости замените





## Biztonsági utasítások

-  A szerelésnél a zúzódások és vágási sérülések elkerülése érdekében kesztyűt kell viselni.
-  A terméket csak fürdéshez, mosakodáshoz, és egészségügyi tisztálkodáshoz szabad használni.
-  Gyermekek, valamint testileg, szellemileg fogyatékos és / vagy érzékelésben korlátozott személyek nem használhatják felügyelet nélkül a terméket. Alkohol és kábítószer befolyása alatt álló személyek nem használhatják a terméket.
-  A hidegvíz- és a melegvíz-csatlakozások közötti nagy nyomáskülönbséget kikell egyenlíteni!

## Szerelési utasítások

A csaptelepet az érvényben lévő előírásoknak megfelelően kell felszerelni, átöblíteni és ellenőrizni!

## Műszaki adatok

Üzemi nyomás:	max. 1 MPa
Ajánlott üzemi nyomás:	0,1 - 0,5MPa
Nyomáspróba:	1,6MPa
(1 MPa = 10 bar = 147 PSI)	
Forróvíz hőmérséklet:	max. 80 °C
Forróvíz javasolt hőmérséklete:	65 °C
Átfolyási teljesítmény 0,3 MPa:	kb. 58 l/perc
Visszafolyás gátlóval	

## Szimbólumok leírása



Ne használjon ecetsavtartalmú szilikont!

## max. Safety Function (Biztonsági funkció) (lásd a 62. oldalon)

≈ 42 °C

A biztonsági funkciónak köszönhetően a kívánt hőmérsékletet pl. 42 Celsius fokban maximálhatjuk.



## Beszerezés (lásd a 63. oldalon)

A sikeres felszerelést követően ellenőrizni kell a termosztát kifolyási hőmérsékletét. Helyesbítés szükséges, ha a vízkivétel helyén mért hőmérséklet eltér a termosztátban beállított hőmérséklettől.



## Karbantartás (lásd a 64. oldalon)

- Ahhoz, hogy a szabályozóegység jól működjön, a termosztátot időről időre teljesen megrege és teljesen hidegre kell állítani.
- A termosztát visszafolyás-gátlóval van felszerelve. A visszafolyásgátlók működése a DIN EN 1717 szabványnak megfelelően, a nemzeti vagy területi rendelkezésekkel összhangban, évente egyszer ellenőrizendő! Ellenőrizze ilyenkor a szennyeződést felfogó szűrőt is, amely az BTC-szabályozóegységben (A) található. Az BTC-szabályozóegység (96633000) beszerelése után feltétlenül ellenőrizze a kifolyó víz hőmérsékletét, mint azt a „Beszabályozás” pont alatt leírtuk. Előzetesen feltétlenül ellenőrizze, hogy a melegvíz ellátás be van-e kapcsolva és hogy a melegvíz maximális hőmérséklete a csapnál rendelkezésre áll-e.



## Méretet (lásd a 66. oldalon)



## Tartozékok (lásd a 68. oldalon)

XXX = Színkódok  
 000 króm  
 090 króm/arany-hatású  
 800 acéloptika  
 820 brushed nickel  
 830 polished nickel



## Használat (lásd a 70. oldalon)



## Tisztítás

lásd a mellékelt brosúrát.



## Vizsgajel (lásd a 67. oldalon)



**Szerelés lásd a 60. oldalon**



Hiba	Ok	Megoldás
Kevés víz	- a nyomás nem megfelelő	- a vezetékek nyomását ellenőrizni kell
	- a szabályozóegység szennyeződést felfogó szűrője koszos	- a szűrőt tisztítani kell
	- a zuhany szűrőtömitése koszos	- a zuhany és a cső közötti szűrőt ki kell tisztítani
Kereszfolyás, a melegvíz a csap zárt állapotában a hidegvíz vezetékbe áramlik és fordítva	- a visszafolyásgátló piszkos vagy hibás	- a visszafolyásgátlót tisztítani kell ill. ki kell cserélni
A kifolyóvíz hőmérséklete nem egyezik a termosztáton beállított hőmérséklettel	- a termosztát nem lett be szabályozva	- a termosztátot be kell szabályozni
	- túl alacsony melegvíz hőmérséklet	- a melegvíz hőmérsékletét 65 fokra kell felemelni
Nem lehetséges a hőmérséklet-szabályozás	- a hőmérséklet szabályozóegység koszos vagy vízköves	- a szabályozó egységet tisztítani ill cserélni kell
	- Újrainstallálásnál az alaptest rosszul csatlakozik (a hideget jobbra, a meleget balra vagy 180 fokkal elforgatva kell beszerelni)	- A funkcióblokkot 180 fokkal való elforgatás után beszerelni.
A biztonsági zár nyomógombja nem működik	- a rugó hibás - a nyomógomb vízköves	- a rugót ill. a nyomógombot ki kell tisztítani és enyhén be kell zsírozni ill. ki kell cserélni





## Turvallisuusohjeet

- △ Asennuksessa on käytettävä käsineitä puristumien ja viiltojen aiheuttamien tapaturmien estämiseksi.
- △ Suihkujärjestelmää saa käyttää ainoastaan kylpy-, hygienia- ja puhdistustarkoituksiin.
- △ Lapset ja ruumiillisesti, henkisesti ja/tai aistillisesti rajoittuneet aikuiset eivät saa käyttää suihkujärjestelmää ilman valvontaa. Alkoholin tai huumeiden vaikutuksessa olevat henkilöt eivät saa käyttää suihkujärjestelmää.
- △ Suuret paine-erot kylmä- ja kuumavesiliitäntöjen välillä on tasattava.

## Asennusohjeet

Kaluste on asennettava, huuhdeltava ja tarkastettava voimassa olevien määräysten mukaisesti!

## Tekniset tiedot

Käyttöpaine:	maks. 1 MPa
Suosittelut käyttöpaine:	0,1 – 0,5MPa
Koestuspaine:	1,6MPa
(1 MPa = 10 bar = 147 PSI)	
Kuuman veden lämpötila:	maks. 80 °C
Kuuman veden suosituslämpötila:	65 °C
Läpivirtausmäärä 0,3 MPa paineella:	n. 58 l/min

Estää itsestään paluuvirtauksen

## Merkin kuvaus



Älä käytä etikkahappopitoista silikonial!

## max. Safety Function (katso sivu 62)

≈ 42 °C

Safety Function:ista johtuen haluttu maksimilämpötila voidaan esiasettaa, esimerkiksi maks. 42° C.



## Säätö (katso sivu 63)

Asennuksen jälkeen termostaatin ulostulolämpötila on tarkastettava. Säätö on tarpeen, jos käyttöpisteessä mitattu veden lämpötila eroaa termostaattiin säädetystä lämpötilasta.



## Huolto (katso sivu 64)

- Sääätöyksikön kevytkäyttöisyyden takaamiseksi, säädä sääätöyksikkö ajoittain täysin kylmälle ja täysin kuumalle.
- Termostaatti on varustettu vastaventtiileillä. Vastaventtiilien toiminta on tarkastettava säännöllisesti paikallisten ja kansallisten määräysten mukaisesti (DIN 1988, kerran vuodessa). Tarkasta tässä yhteydessä myös likasidit, jotka ovat BTC-sääätöyksikössä (A). BTC-sääätöyksikön (96633000) asentamisen jälkeen ulostulevan veden lämpötila on tarkastettava kuten kohdassa "Säätö" on kuvattu. Tarkasta ehdottomasti sitä ennen, onko kuuman veden syöttö kytketty päälle ja, että syöttöpisteessä on kuuman veden maks. lämpötila.



## Mitat (katso sivu 66)



## Varaosat (katso sivu 68)

XXX = Värikoodi

000 kromi

090 kromi/kultaoptiikka

800 inox-optinen

820 harjattu nikkeli

830 kiillotettu nikkeli



## Käyttö (katso sivu 70)



## Puhdistus

katso oheinen esite

## Koestusmerkki (katso sivu 67)



# Asennus katso sivu 60







Häiriö	Syy	Toimenpide
Vähän vettä	- Syöttöpaine ei ole riittävä	- Tarkasta putkiston paine
	- Lämpötilan säätöyksikön likasihti likaantunut	- Puhdista likasihdit
	- Käsisuihkun sihtitiiviste likaantunut	- Puhdista suihkukahvan ja letkun välissä oleva sihtitiiviste
Ristiinvirtaus, hanan ollessa kiinni lämmin vesi pääsee virtaamaan kylmänveden putkeen tai päinvastoin.	- Suuntaisventtiili likaantunut / viallinen	- Puhdista suuntaisventtiili, vaihda tarvittaessa
Veden ulostulolämpötila ei vastaa säädettyä lämpötilaa	- Termostaattia ei ole säädetty	- Sääddä termostaatti
	- Lämminveden lämpötila liian alhainen	- Kohota lämminveden lämpötila arvoon välillä 42°C ja 65°C
Lämpötilan säätö ei ole mahdollista	- Lämpötilansäätöyksikkö likaantunut tai kalkkeutunut	- Puhdista lämpötilansäätöyksikkö, vaihda tarvittaessa
	- Liitokset perusrunkoon on asennettaessa tehty väärin (pitää olla: kylmä oikealla, lämmin vasemmalla) tai perusrunko on asennettu 180°-käännettynä	- Asenna toimintalohko 180° käännettynä paikalleen
Veden lämpötilan turvarajoittimen painonappi ei toimi	- Jousi ei toimi	- Puhdista ja voitele kevyesti jousi ja/
	- Painonappi on kalkkeutunut	tai painonappi, vaihda tarvittaessa





## **Säkerhetsanvisningar**

-  Handskar ska bäras under monteringsarbetet så att man kan undvika kläm- och skärskadorgen werden.
-  Produkten får bara användas till kroppshygien med bad och dusch.
-  Barn samt vuxna med fysiska, psykiska eller sensoriska funktionshinder får inte använda produkten ensamma. Personer som är påverkade av alkohol- eller droger får inte använda produkten.
-  Stora tryckskillnader mellan anslutningarna för varmt och kallt vatten måste utjämnas.

## **Monteringsanvisningar**

Blandaren måste installeras, genomspolas och testas enligt gällande föreskrifter.

## **Tekniska data**

Driftstryck:	max. 1 MPa
Rek. driftstryck:	0,1 – 0,5MPa
Tryck vid provtryckning:	1,6MPa
(1 MPa = 10 bar = 147 PSI)	
Varmvattentemperatur:	max. 80 °C
Rek. varmvattentemp.:	65 °C
Flödeskapacitet vid 0,3 MPa:	ca. 58 l/min
Självspärr mot återflöde	

## **Simbolio aprašymas**



Använd inte silikon som innehåller ättiksyra!

## **max. Safety Function** (se sidan 62)

≈ 42 °C

Med hjälp av Safety Function kan du ställa in den önskade maximaltemperaturen till exempelvis 42°C och så förhindra skållningsrisk för barn.



## **Inställning av maxtemperatur** (se sidan 63)

När monteringen är klar måste termostatens tömningstemperatur kontrolleras. En justering är nödvändig om den uppmätta temperaturen vid tappningsstället avviker från den som är inställd på termostaten.



## **Skötsel** (se sidan 64)

- För att garantera att termostaten ej kalkar igen, ska den regelbundet, en gång per vecka, konditioneras. Det sker genom att man några gånger snabbt slås om temperaturen från hett till kallt och tillbaka.
- Termostaten är utrustad med backventiler. Backventilers funktion måste kontrolleras regelbundet enligt nationella eller regionala bestämmelser (DIN 1988 en gång per år) i ilighet med DIN EN 1717. Kontrollera även smutsfiltren som sitter på termosensorn (A) vid detta tillfälle. När termosensorn (96633000) har monterats måste uttemperaturen kontrolleras, enligt beskrivning under avsnitt "Inställning". Kontrollera först om varmvattenförsörjningen är inkopplad och att max. varmvattentemperatur är uppnådd vid tappstället.



## **Måtten** (se sidan 66)



## **Reservdelar** (se sidan 68)

XXX = Färgkodning  
 000 krom  
 090 krom/guld-optik  
 800 rostfri-optik  
 820 borstad nickel  
 830 polerad nickel



## **Hantering** (se sidan 70)



## **Rengöring**

se den medföljande broschyren



## **Testsgill** (se sidan 67)



## **Montering se sidan 60**





<b>Störning</b>	<b>Orsak</b>	<b>Åtgärd</b>
För lite vatten	- Vattentrycket är för lågt	- Kontrollera ledningstryck
	- Smutsfilter i styrenheten igensatt	- Rengör smutsfilter
	- Silfiltret i duschen smutsigt	- Rengör silfiltret mellan slangen och termostaten
Korsflöde – varmt vatten pressas vid avstängd ermostat in i kallvatten- inloppet, och vice versa	- Backventil är igensmutsad eller otät	- Rengör backventil, byt ut om nödvändigt
Den faktiska vatten- temperaturen stämmer inte överens med den inställda	- Termostaten ställdes inte in	- Justera termostaten
	- Varmvattentemperaturen är för låg	- Höj varmvattentemperaturen till mellan 42°C och 65°C
Temperaturen kan ej ställas in	- Temperaturinställning smutsig eller täckt av kalk	- Rengör temperaturinställningen, byt ut om nödvändigt
	- Grundkonstruktionen anslöts på fel sätt vid nyinstallation (ska vara: kallt höger, varmt vänster) eller monterades med 180° förskjutning	- Montera funktionsblocket med 180° förskjutning
Tryckknappen till säkerhetspärren har ingen funktion	- Fjäder defekt - Tryckknapp förkalkad	- Rengör fjäder eller tryckknapp och smörj in något, eller byt ut om detta behövs





## Saugumo technikos nurodymai

- ⚠️ Apsaugai nuo užspaudimo ir įsijovimo montavimo metu mūvėkite pirštines.
- ⚠️ Gaminys turi būti naudojamas tik maudymuisi, kūno higienai ir švarai palaikyti.
- ⚠️ Gaminį draudžiama naudoti vaikams, taip pat suaugusiems su fizine, dvasine negale ir (arba) sensorikos sutrikimais. Gaminį taip pat draudžiama naudoti asmenims, apsvaigusiems nuo alkoholio arba narkotikų.
- ⚠️ Turi būti išlyginti šalto ir karšto slėgio nelygumai.

## Montavimo instrukcija

Maišytuvas privalo būti montuojamas, išleidžiamas ir patikrinamas pagal galiojančias normas!

## Techniniai duomenys

Darbinis slėgis: ne daugiau kaip 1 MPa  
 Rekomenduojamas slėgis: 0,1 – 0,5MPa  
 Bandomasis slėgis: 1,6MPa  
 (1 MPa = 10 barų = 147 PSI)  
 Karšto vandens temperatūra: ne daugiau kaip 80 °C  
 Rekomenduojama karšto vandens temperatūra: 65 °C  
 Vandens pralaidumas, esant 0,3 MPa slėgiui: apie 58 l/min  
 Su atbuliniu vožtuvu

## Simbolio aprašymas



Nenaudokite silikono, kurio sudėtyje yra acto rūgšties!

## max. Apsaugos funkcija (žr. psl. 62) ≈ 42 °C

“Safety” funkcija karšto vandens temperatūra gali būti iš anksto ribota iki, pvz., ne aukštesnės kaip 42 °C.



## Nustatymas (žr. psl. 63)

Sumontavus, būtina patikrinti vandens, išeinančio iš termostato, temperatūrą. Pakoreguokite vandens temperatūrą, jei būtina.



## Techninis aptarnavimas (žr. psl. 64)

- Tam, kad būtų garantuotas tolygus temperatūros reguliavimas ir ilgas naudojimasis, būtina periodiškai temperatūros rankenėlę pasukti į karščiausios ir šalčiausios temperatūros padėtį.
- Termostatas yra su grįžtamosios srovės sustabdymo vožtuvais. Atbulinio vožtuvo apsauga privalo būti tikrinama reguliariai (mažiausiai kartą per metus pagal DIN 1988) pagal DIN EN1717 arba pagal galiojančias nacionalines arba regionines normas. Tuo pačiu būtina patikrinti filtrą, kuris yra ant termoelemento sienelės (A). Pakeitus termoelementą (96633000), būtina patikrinti vandens temperatūrą ir nustatyti karšto vandens ribojimą (žr. temperatūros nustatymą). Prieš reguliavimą patikrinkite, ar tiekiamas karštas vanduo ir kokia jo didžiausia temperatūra iškėlimo vietoje.



## Išmatavimai (žr. psl. 66)



## Atsarginės dalys (žr. psl. 68)

XXX = Spalva  
 000 chrom  
 090 chrominė (aukso optika)  
 800 plienas  
 820 brushed nickel  
 830 polished nickel



## Eksplotacija (žr. psl. 70)



## Valymas

žr. pridedamoje brošiūroje.



## Bandyimo pažyma (žr. psl. 67)









<b>Gedimas</b>	<b>Priežastis</b>	<b>Priemonė</b>
Per maža srovė	- Slėgis nepakankamas	- Patikrinti vamzdžių spaudimą
	- Užsikimšęs temperatūros regulatoriaus filtras	- Išvalyti filtrą
	- Dušo galvos filtras užsikimšęs	- Išvalyti dušo galvos filtrą
Kryžminis tekėjimas, uždarius maišytuvą, karštas vanduo papuola į šalto vandens vamzdį	- Atbulinis vožtuvas užsikimšęs / pažeistas	- Išvalyti arba pakeisti atbulinį vožtuvą
Vandens temperatūra nesutampa su nustatyta temperatūra	- Termostatas nereguliuotas	- Reguluoti termostatą
	- Per maža karšto vandens temperatūra	- Karšto vandens temperatūrą pakelti nuo 42 °C bis 65 °C
Temperatūros reguliavimas neįmanomas	- Temperatūros reguliatorius užsikimšęs arba apkalkėjęs	- Išvalyti arba pakeisti temperatūros reguliatorių
	- Neteisingai prijungti vamzdžiai: karštas turi būti kairėje, šaltas - dešinėje	- Sumontuoti funkcijos blokažimą 180°
Ribotuvo mygtukas neveikia	- Spyruoklė pažeista - Mygtukas apkalkėjęs	- Išvalyti spyruoklę/mygtuką ir sutepti arba keisti





## Sigurnosne upute

-  Prilikom montaže se radi sprječavanja prignječenja i posjekotina moraju nositi rukavice.
-  Proizvod se smije primjenjivati samo za kupanje, tuširanje i osobnu higijenu.
-  Djeca, kao i tjelesno, mentalno i/ili senzorno hendikepirane odrasle osobe ne smiju se koristiti proizvodom bez nadzora. Osobe koje su pod utjecajem alkohola ili droga ne smiju se koristiti proizvodom.
-  Velika razlika u pritisku između vruće i hladne vode mora biti izbalansirana.

## Upute za montažu

Cijevi moraju biti postavljene, isprane i testirane prema važećim normama!

## Tehnički podaci

Najveći dopušteni tlak:	tlak 1 MPa
Preporučeni tlak:	0,1 – 0,5MPa
Probni tlak:	1,6MPa
(1 MPa = 10 bar = 147 PSI)	
Temperatura vruće vode:	tlak 80 °C
Preporučena temperatura vruće vode:	65 °C
Protok vode uz tlak od 0,3 MPa:	oko 58 l/min
Funkcije samo-čišćenja	

## Opis simbola



Nemojte koristiti silikon koji sadrži octenu kiselinu!

## max. Safety Funkcija (pogledaj stranicu 62) **≈ 42 °C**

Zahvaljujući Safety funkciji može se podesiti željena maksimalna temperatura, npr. i 42° C



## Regulacija (pogledaj stranicu 63)

Nakon instalacije treba ispitati izlaznu temperaturu termostata. Korekcija je neophodna, ako izmjerena temperatura na mjestu uzimanja odstupa od temperature koja je namještena na termostatu.



## Održavanje (pogledaj stranicu 64)

- Kako bi se olakšala prohodnost i produžio vijek trajanja regulacijske jedinice, potrebno je s vremena na vrijeme podesiti termostat iz položaja maksimalno tople u položaj maksimalno hladne vode.
- Termostat je opremljen nepovratnim ventilom. Ispravnost nepovratnog ventila mora se redovito provjeravati prema standardu DIN EN 1717 i u skladu sa važećim propisima (najmanje jednom godišnje). Također ispitajte ispravnost filtera za prljavštinu koji se nalazi na BTC regulacijskoj jedinici. (A) Nakon instalacije BTC regulacijske jedinice (96633000) obavezno ispitajte toplinu vode na slavini kao što je opisano pod točkom "Regulacija". No prije toga svakako ispitajte je li uključen sustav za opskrbu toplom vodom i izlazi li na probnom mjestu voda s maksimalnom temperaturom u odnosu na dispoziciju



## Mjere (pogledaj stranicu 66)



## Rezervni dijelovi (pogledaj stranicu 68)

XXX = Boje  
 000 krom  
 090 optika krom/zlato  
 800 plemeniti čelik  
 820 brushed nickel  
 830 polished nickel



## Upotreba (pogledaj stranicu 70)



## Čišćenje

se u priloženoj brošuri.



## Oznaka testiranja (pogledaj stranicu 67)



## Sastavljanje pogledaj stranicu 60



<b>Greška</b>	<b>Uzrok</b>	<b>Otklanjanje</b>
Nedovoljno vode	- Prenizak pritisak vode	- Ispitajte tlak u cijevima
	- Očistite rešetkasti filter regulacijske jedinice	- Očistite rešetkasti filter ispred termostata i na regulacijskoj jedinici
	- Filter tuša je prljav	- Očistite filter između tuša i crijeva
Križni tok vode, kod zatvorene armature vruća voda ulazi u cijev s hladnom vodom i obrnuto	- Nepovratni ventil je prljav/ neispravan	- Očistite ili zamijenite nepovratni ventil
Temperatura na slavini ne podudara se s podešenom temperaturom	- Termostat nije podešen	- Podesite termostat
	- Preniska temperatura tople vode	- Povećajte temperaturu vruće vode na 42-65 °C
Reguliranje temperature nije moguće	- Regulator temperature je prljav ili obložen naslagama kamenca	- Očistite ili zamijenite regulator temperature.
	- Pri ponovnoj instalaciji tijelo je pogrešno priključeno (potrebno je priključiti hladnu vodu desno, a vruću lijevo) ili je zakrenuto za 180 stupnjeva.	- Unutarnji blok okrenite za 180 stupnjeva
Tipkalo sigurnosnog prekida je van funkcije	- Opruga je neispravna - Tipkalo je začepljeno slojem kamenca	- Očistite i podmažite oprugu, tj. tipkalo, u slučaju potrebe tipkalo možete zamijeniti novim





## Güvenlik uyarıları

- ⚠ Montaj esnasında ezilme ve kesilme gibi yaralanmaları önlemek için eldiven kullanılmalıdır.
- ⚠ Duş sistemi yalnızca banyo, hijyen ve beden temizliği amaçları doğrultusunda kullanılabilir.
- ⚠ Bedensel, ruhsal ve/veya sensörük engelli çocuk ve yetişkinler gözetimsiz olarak duş sistemini kullanmamalıdır. Alkol veya uyuşturucu etkisinde olanlar duş sistemini kullanmamalıdır.
- ⚠ Sıcak ve soğuk su bağlantıları arasında büyük basınç farklılıkları varsa, bu basınç farklılıklarının dengelenmesi gerekir.

## Montaj açıklamaları

Batarya geçerli normlara göre monte edilmeli, yıkanmalı ve kontrol edilmelidir!

## Teknik bilgiler

İşletme basıncı:	azami 1 MPa
Tavsiye edilen işletme basıncı:	0,1 - 0,5MPa
Kontrol basıncı:	1,6MPa
(1 MPa = 10 bar = 147 PSI)	
Sıcak su sıcaklığı:	azami 80 °C
Tavsiye edilen su ısısı:	65 °C
0,3 MPa'daki debi:	yaklaşık 58 l/dak
Geri emme önleyici	

## Simge açıklaması



Asetik asit içeren silikon kullanmayın!

## max. Safety Function (Bakınız sayfa 62)

≈ 42 °C

Emniyet fonksiyonu sayesinde, istenen maksimum sıcaklık Örn; maks. 42° C önceden ayarlanabilir.



## Ayarlama (Bakınız sayfa 63)

Montaj tamamlandıktan sonra, termostatların çıkış sıcaklığı kontrol edilmelidir. Alma noktasında ölçülen sıcaklık termostatta ayarlanan sıcaklıktan farklıysa, bir düzeltme gereklidir.



## Bakım (Bakınız sayfa 64)

- Ayar ünitesinin kolay hareket etmesini sağlamak için, termostat belirli aralıklarla tamamen sıcak ve soğuk konuma getirilmelidir.
- Termostat, çek valflerle donatılmıştır. DIN EN 1717 ve ulusal standartlar doğrultusunda Çek valfler düzenli olarak kontrol edilmelidir. ( en az yılda bir kez) Bu fırsatı kullanarak, BTC ayar ünitesinde (A) bulunan kir tutucuları da kontrol edin. BTC ayar ünitesini (96633000) taktıktan sonra, "Ayarlama" maddesinde tarif edildiği gibi çıkış sıcaklığını da mutlaka kontrol edin. Daha önce, muylu noktasında sıcak su beslemesi ve maksimum sıcak su sıcaklığının mevcut olup olmadığını da mutlaka kontrol edin.



## Ölçüleri (Bakınız sayfa 66)



## Yedek Parçalar (Bakınız sayfa 68)

XXX = Renkler

000 krom

090 krom/altın-optik

800 paslanmaz çelik - optik

820 brushed nickel

830 polished nickel



## Kullanımı (Bakınız sayfa 70)



## Temizleme

birlikte verilen broşür

## Kontrol işareti (Bakınız sayfa 67)









<b>arıza</b>	<b>sebep</b>	<b>yardım</b>
Az su geliyor	- Besleme basıncı yeterli değil - Ayar ünitesinin filtresi kirlenmiş - Duşun süzgeci tıkanmış olabilir	- Hat basıncını kontrol edin - Filtreleri temizleyin - El duşu ile hortum arasındaki hortumu yıkayın
Çapraz akış, batarya kapalıyken sıcak su soğuk su hattına gönderiliyor ya da tam tersi	- Çek valf kirlenmiş / arızalı	- Çek valfi temizleyin ya da değiştirin
Çıkış sıcaklığı ayarlanan sıcaklıkla aynı değil	- Termostat ayarlanmadı - Sıcak suyun derecesi çok düşük	- Termostatı ayarlayın - Sıcak su sıcaklığını 42 °C ila 65 °C'ye yükseltin
Sıcaklık ayarı mümkün değil	- Sıcaklık ayar ünitesi kirlenmiş ya da kireçlenmiş - Yeni montaj sırasında ana gövde yanlış bağlanmış (Olması gereken: soğuk sağ tarafa, sıcak sol tarafa) ya da 180° döndürülerek takılmış	- Sıcaklık ayar ünitesini temizleyin, gerekirse değiştirin - Fonksiyon bloğunu 180° döndürerek takın
Emniyet kilidinin düğmesi çalışmıyor	- Yay arızalı - Düğme kireçlenmiş	- Yayı ya da düğmeyi temizleyin ve hafifçe gres sürün, gerekirse değiştirin





## Instrucțiuni de siguranță

-  La montare utilizați mănuși pentru evitarea contuziunilor și tăierii mâinilor.
-  Sistemul de duș poate fi utilizat doar pentru spălarea, menținerea igienei și curățarea corpului.
-  Copiii și adulții cu dizabilități corporale, min-tale și senzoriale nu pot utiliza sistemul de duș nesupravegheați. De asemenea este interzisă utilizarea sistemului de duș de către persoane, care se află sub influența alcoolului sau a drogurilor.
-  Diferențele de presiune mari între alimentarea cu apă rece și apă caldă trebuie echilibrate.

## Instrucțiuni de montare

Bateria trebuie montată, clătită și verificată conform normelor în vigoare.

### Date tehnice

Presiune de funcționare:	max. 1 MPa
Presiune de funcționare recomandată:	0,1 - 0,5MPa
Presiune de verificare:	1,6MPa
(1 MPa = 10 bar = 147 PSI)	
Temperatura apei calde:	max. 80 °C
Temperatura recomandată a apei calde:	65 °C
Debit de apă la 0,3 MPa:	cca. 58 l/min
Asigurat contra scurgere înapoi	

## Descrierea simbolurilor



Nu utilizați silicon cu conținut de acid acetic!

**max. Funcția de siguranță** (vezi pag. 62)  
**≈ 42 °C**

Datorită funcției de siguranță puteți preregla temperatura maximă, de ex. 42° C.



**Reglare** (vezi pag. 63)

După montare verificați temperatura de ieșire la termostat. În cazul în care există o diferență între temperatura măsurată la goler și temperatura reglată la termostat trebuie efectuată o corecție.



**Întreținere** (vezi pag. 64)

- Pentru garantarea mișcării ușoare a unității de reglare, vă recomandăm să setați termostatul pe pozițiile limită cald și rece.
- Termostatul este dotat cu supape antiretur. Supapele de reținere trebuie verificate regulat conform DIN EN 1717 și standardele naționale sau regionale (anual conform DIN 1988). Verificați cu această ocazie și sita pentru impurități aflată pe unitatea de reglare BTC (A). După montarea unității de reglare BTC (96633000) verificați temperatura de ieșire conform celor descrise în cap. "Reglare". Verificați neapărat în prealabil, dacă s-a pornit alimentarea cu apă caldă și apa are temperatura maximă la intrare.



**Dimensiuni** (vezi pag. 66)



**Piese de schimb** (vezi pag. 68)

XXX = cod de culori  
 000 crom  
 090 crom/auriu optic  
 800 otel inox  
 820 nichel mat  
 830 nichel lucios



**Utilizare** (vezi pag. 70)



**Curățare**

vezi broșura alăturată.



**Certificat de testare** (vezi pag. 67)



**Montare vezi pag. 60**









<b>Deranjament</b>	<b>Cauza</b>	<b>Măsuri de remediere</b>
Prea puțină apă	- Presiune de alimentare insuficientă.	- Verificați presiunea din conducte.
	- Murdărie în sita de impurități a unității de reglare.	- Curățați sitele de impurități.
	- S-a murdărit garnitura de sită a capătului de duș.	- Curățați garnitura sită dintre capătul duș și furtun.
Curgere încuciată, apa caldă intră în conducta de apă rece sau invers, când bateria este închisă.	- S-a murdărit / s-a defectat supapa antiretur.	- Curățați sau schimbați supapa antiretur dacă este cazul.
Temperatura apei la ieșire nu corespunde cu temperatura reglată.	- Termostatul nu a fost reglat.	- Reglați termostatul.
	- Temperatura apei calde este prea mică	- Ridicați temperatura apei calde la o temperatură între 42 °C și 65 °C.
Temperatura nu poate fi reglată.	- Unitatea de reglare a temperaturii murdar sau cu depuneri de calcar.	- Curățați sau schimbați unitatea de reglare a temperaturii dacă este cazul.
	- Bateria a fost racordată incorect la prima instalare. (instalați rece - dreapta, cald - stânga) sau rotit cu 180°.	- Montați invers blocul de funcții (rotit cu 180°).
Butonul de pe întrerupătorul de siguranță nu funcționează.	- Arc defect	- Curățați și ungeți puțin arcul și butonul sau schimbați-le dacă este cazul.
	- Depuneri de calcar pe buton	





## Υποδειξεις ασφαλείας

-  Για να αποφύγετε τραυματισμούς κατά τη συναρμολόγηση πρέπει να φοράτε γάντια.
-  Το προϊόν επιτρέπεται να χρησιμοποιείται μόνο σαν μέσο λουτρού, υγιεινής και καθαρισμού του σώματος.
-  Παιδιά ή ενήλικες με μειωμένες σωματικές, διανοητικές και/ή αισθητήριες ανεπάρκειες δεν επιτρέπεται να χρησιμοποιούν το προϊόν χωρίς επιτήρηση. Άτομα υπό την επήρεια οινοπνεύματος ή ναρκωτικών δεν επιτρέπεται να χρησιμοποιούν σε καμία περίπτωση το προϊόν
-  Οι διαφορές της πίεσης μεταξύ της σύνδεσης κρύου και ζεστού νερού θα πρέπει να αντισταθμίζονται.

## Οδηγίες συναρμολόγησης

Η κεντρική βάνα πρέπει να τοποθετηθεί, να πλυθεί και να ελεγχθεί με βάση τους ισχύοντες κανόνες υδραυλικής τέχνης!

## Τεχνικά Χαρακτηριστικά

Λειτουργία πίεσης:	έως 1 MPa
Συνιστώμενη λειτουργία πίεσης:	0,1 - 0,5MPa
Πίεση ελέγχου:	1,6MPa
(1 MPa = 10 bar = 147 PSI)	
Θερμοκρασία ζεστού νερού:	έως 80 °C
Συνιστώμενη θερμοκρασία ζεστού νερού:	65 °C
Κατανάλωση νερού στα 0,3 MPa:	περ. 58 l/min
Περιλαμβάνει βαλβίδα αντεπιστροφής.	

## Περιγραφή συμβόλων



Μην χρησιμοποιείτε σιλικόνη που περιέχει οξικό οξύ!

**max. Safety Function** (Λειτουργία ασφαλείας) (βλ. σελίδα 62)

≈ 42 °C

Χάρη στη λειτουργία ασφαλείας Safety Function, είναι δυνατή η προρρύθμιση της επιθυμητής μέγιστης θερμοκρασίας (π.χ. 42° C).



**Ρύθμιση** (βλ. σελίδα 63)

Αφότου πραγματοποιηθεί η συναρμολόγηση, θα πρέπει να ελεγχθεί η θερμοκρασία του στομίου εκροής του θερμοστάτη. Μία διόρθωση είναι απαραίτητη όταν η μετρούμενη στο σημείο λήψης θερμοκρασία αποκλίνει από τη ρυθμισμένη στο θερμοστάτη θερμοκρασία.



**Συντήρηση** (βλ. σελίδα 64)

- Για να διασφαλίσετε την καλή λειτουργία της μονάδας ρύθμισης, θα πρέπει να ρυθμίζετε το θερμοστάτη από καιρού εις καιρόν σε εντελώς ζεστό ή εντελώς κρύο.
- Ο θερμοστάτης είναι εξοπλισμένος με μία βαλβίδα αντεπιστροφής. Οι βαλβίδες αντεπιστροφής πρέπει να ελέγχονται τακτικά ως προς τη λειτουργία τους, σύμφωνα με τις οδηγίες DIN EN 1717, σε σχέση με τους ισχύοντες εθνικούς ή τοπικούς κανόνες (το ελάχιστο μια φορά το χρόνο, σύμφωνα με το πρότυπο DIN 1988) Με την ευκαιρία αυτή, ελέγξτε τους συλλέκτες ακαθαρσιών, οι οποίοι βρίσκονται επάνω στη μονάδα ρύθμισης BTC (A). Μετά τη συναρμολόγηση της μονάδας ρύθμισης BTC (96633000), να ελέγχετε οπωσδήποτε τη θερμοκρασία εκροής, όπως περιγράφεται στην ενότητα "Ρύθμιση". Ελέγξτε οπωσδήποτε προκαταβολικά, εάν η παροχή νερού είναι ενεργοποιημένη και εάν η θερμοκρασία του νερού στο σημείο λήψης έχει τη μέγιστη τιμή της.



**Διαστάσεις** (βλ. σελίδα 66)



**Ανταλλακτικά** ( βλ. σελίδα 68 )

XXX = Χρώματα  
000 Επιχρωμασμένο  
090 Επιχρωμασμένο/οπτική χρυσού  
800 οπτική ανοξείδωτου χάλυβα  
820 νίκελ ματ  
830 νίκελ γυαλιστερό



**Χειρισμός** (βλ. σελίδα 70)



**Καθαρισμός**

βλ. συνημμένο φυλλάδιο



**Σήμα ελέγχου** (βλ. σελίδα 67)









<b>Βλάβη</b>	<b>Αιτία</b>	<b>Διόρθωση</b>
Ανεπαρκές νερό	<ul style="list-style-type: none"> <li>- Η πίεση παροχής δεν είναι επαρκής</li> <li>- Βρώμικο φίλτρο συλλογής ακαθαρσιών της μονάδας ρύθμισης</li> <li>- Βρώμικη στεγανοποιητική σήτα του καταιονιστήρα</li> </ul>	<ul style="list-style-type: none"> <li>- Ελέγξτε την πίεση των αγωγών αποχέτευσης/ύδρευσης</li> <li>- Καθαρίστε τα φίλτρα συλλογής ακαθαρσιών</li> <li>- Καθαρίστε και, εάν χρειαστεί, αλλάξτε τη στεγανοποιητική σήτα μεταξύ καταιονιστήρα και σπιράλ</li> </ul>
Η σταυροειδής ροή και το ζεστό νερό ρυθμίζονται με κλειστή βάνα στον αγωγό κρύου νερού, πατώντας τη βάνα ή αντίστροφα	<ul style="list-style-type: none"> <li>- Βρώμικη/ελαττωματική βαλβίδα αντεπιστροφής</li> </ul>	<ul style="list-style-type: none"> <li>- Καθαρίστε και, εάν χρειαστεί, αλλάξτε τη βαλβίδα αντεπιστροφής</li> </ul>
Η θερμοκρασία εκροής δεν συμφωνεί με τη ρυθμισμένη θερμοκρασία	<ul style="list-style-type: none"> <li>- Ο θερμοστάτης δεν έχει ρυθμιστεί</li> <li>- Χαμηλή θερμοκρασία ζεστού νερού</li> </ul>	<ul style="list-style-type: none"> <li>- Ρυθμίστε το θερμοστάτη</li> <li>- Αυξήστε τη θερμοκρασία του ζεστού νερού μεταξύ των 42°C και των 65°C</li> </ul>
Δεν είναι δυνατή η ρύθμιση της θερμοκρασίας	<ul style="list-style-type: none"> <li>- Η μονάδα ρύθμισης θερμοκρασίας είναι βρώμικη ή φέρει άλατα</li> <li>- Σε νέα εγκατάσταση: Λάθος σύνδεση βασικού κορμού (θα πρέπει: κρύο δεξιά, ζεστό αριστερά) ή ο βασικός κορμός έχει εγκατασταθεί περιστρεφόμενος κατά 180°</li> </ul>	<ul style="list-style-type: none"> <li>- Καθαρίστε και, εάν χρειαστεί, αλλάξτε τη μονάδα ρύθμισης θερμοκρασίας</li> <li>- Εγκαταστήστε το σώμα λειτουργίας περιστρέφοντάς το κατά 180°</li> </ul>
Πιεστικό κουμπί ή διάταξη φραγής ασφαλείας χωρίς λειτουργία	<ul style="list-style-type: none"> <li>- Ελαττωματικό ελατήριο</li> <li>- Αφαλατωμένο πιεστικό κουμπί</li> </ul>	<ul style="list-style-type: none"> <li>- Καθαρίστε και λιπάνετε ελαφρά, και, εάν χρειαστεί, αλλάξτε το ελατήριο ή/και το πιεστικό κουμπί</li> </ul>





## Varnostna opozorila

-  Pri montaži je treba nositi rokavice, da se preprečijo poškodbe zaradi zmečkanja ali urezov.
-  Ta izdelek se sme uporabljati le z namenom umivanja, vzdrževanja higiene in telesne nege.
-  Otroci kot tudi odrasle osebe z omejenimi telesnimi, duševnimi in/ali senzoričnimi sposobnostmi ne smejo nenadzorovano uporabljati tega izdelka. Osebe, ki so pod vplivom alkohola ali drog, tega izdelka ne smejo uporabljati.
-  Il est conseillé d'équilibrer les pressions de l'eau chaude et froide.

## Navodila za montažo

Armaturu je potrebno montirati, sprati in testirati v skladu z veljavnimi normami!

## Tehnični podatki

Delovni tlak:	maks. 1 MPa
Priporočeni delovni tlak:	0,1 – 0,5MPa
Preskusni tlak:	1,6MPa
(1 MPa = 10 bar = 147 PSI)	
Temperatura tople vode:	maks. 80 °C
Priporočena temperatura tople vode:	65 °C
Pretok vode pri 0,3 MPa:	ca. 58 l/min
Zaščita proti povratnemu toku	

## Opis simbola



Ne smete uporabiti silikona, ki vsebuje ocetno kislino!

## max. Varnostna funkcija . (glejte stran 62)

≈ 42 °C

Varnostna funkcija omogoča, da vnaprej nastavimo najvišjo želeno temperaturo npr. 42° C.



## Nastavitev (glejte stran 63)

Po opravljeni montaži je treba preveriti iztočno temperaturo na termostatu. Če na odvzemnem mestu izmerjena temperatura odstopa od temperature, nastavljene na termostatu, je potreben popravek.



## Vzdrževanje (glejte stran 64)

- Da bi zagotovili gladko delovanje enote za uravnavanje, je potrebno termostat občasno nastaviti popolnoma na toplo in popolnoma na mrzlo.
- Termostat je opremljen s protipovratnim ventilom. Delovanje protipovratnega ventila je potrebno v skladu z DIN EN 1717 in skladno z državnimi in regionalnimi določili (DIN 1988 enkrat letno) redno testirati. Ob tej priložnosti preverite tudi filtre, ki se nahajajo na enoti za uravnavanje BTC (A). Po montaži BTC-enote (96633000) nujno preverite temperaturo izliva, kot je to opisano pod točko "Justiranje". Pred tem nujno preverite, da je oskrba s toplo vodo vključena in da je maksimalna temperatura tople vode na mestu odvzema na voljo.



## Mere (glejte stran 66)



## Rezervni deli (glejte stran 68)

XXX = Barve

- 000 krom
- 090 krom/pozlačena
- 800 videz legiranega jekla
- 820 brushed nickel
- 830 polished nickel



## Upravljanje (glejte stran 70)



## Čiščenje

glejte priloženi brošuri.



## Preskusni znak (glejte stran 67)





<b>Napaka</b>	<b>Vzrok</b>	<b>Pomoč</b>
Malo vode	- Ne zadosten oskrbovalni tlak	- Preverite tlak v ceveh
	- Filter enote za uravnavanje je umazan	- Očistite filtre
	- Filtrirna mrežica prhe je umazana	- Očistite filtrirno mrežico med prho in gibko cevjo
Križni tok, toplo vodo ob zaprti armaturi potiska v cevi mrzle vode ali obratno	- Protipovratni ventil je umazan/pokvarjen	- Očistite oz. po potrebi zamenjajte protipovratni ventil
Temperatura vode pri izlivu ne ustreza temperaturi, ki ste jo nastavili.	- Termostat ni bil justiran	- Justirajte termostat
	- Prenizka temperatura tople vode	- Povišajte temperaturo tople vode na 42 °C do 65 °C
Uravnavanje temperature ni mogoče	- Enota za uravnavanje temperature je umazana ali poapnena	- Očistite oz. po potrebi zamenjajte enoto za uravnavanje temperature
	- Pri novi inštalaciji je osnovni del napačno priključen (moralo bi biti: mrzlo desno, toplo levo) ali vgrajen z zasukom za 180°.	- Vgradite funkcijski blok za 180° obrnjeno
Gumb varnostne zapore ne deluje	- Pokvarjena vzmet	- Očistite in rahlo namastite oz. po potrebi zamenjajte vzmet oz. gumb
	- Gumb je poapnen	





## Ohutusjuhised

- △ Kandke paigaldamisel muljumis- ja löikevigastuste vältimiseks kindaid.
- △ Toodet tohib kasutada ainult pesemis-, hügieeni- ja kehapihustamisesmärkidel.
- △ Lapsed, samuti kehaliste, vaimsete või tajupiiirangutega täiskasvanud ei tohi dušisüsteemi järelevalveta kasutada. Alkoholi või narkootikumide mõju all olevad isikud ei tohi dušisüsteemi kasutada.
- △ Kui külma ja kuumu vee ühenduste surve on väga erinev, tuleb need tasakaalustada.

## Paigaldamisjuhised

Segisti paigaldamine, loputamine ja kontroll peab toimuma vastavalt kehtivatele normidele!

## Tehnilised andmed

Töörõhk	maks. 1 MPa
Soovitatav töörõhk:	0,1 – 0,5MPa
Kontrollsurve:	1,6MPa
(1 MPa = 10 baari = 147 PSI)	
Kuumu vee temperatuur:	maks. 80 °C
Soovitatav kuumu vee temperatuur:	65 °C
Läbivool, kui rõhk on 0,3 MPa:	u. 58 l/min

tagasivooluklapp

## Sümbolite kirjeldus



Ärge kasutage äädikhapet sisaldavat silikooni!

## max. Turvafunktsioon (vt lk 62)

≈ 42 °C

Tänu ohutusfunktsioonile on võimalik soovitud maksimaaltemperatuuri eelnevalt sisestada (nt maks. 42 °C).



## Reguleerimine (vt lk 63)

Paigaldamise järel tuleb kontrollida termostaadi väljundtemperatuuri. Kui väljavoolu kohas mõõdetud temperatuur erineb termostaadiga sisestatud, tuleb seda reguleerida.



## Hooldus (vt lk 64)

- Termostaadi hea toimimise tagamiseks on tarvis termostaati keerata aeg-ajalt päris kuumu ja päris külma peale.
- Termostaati on varustatud tagasilöögiklappidega. Tagasilöögiklappide toimimist tuleb kooskõlas riiklike ja regionaalsete määrustega regulaarselt kontrollida vastavalt standardile DIN EN 1717 (DIN 1988 - kord aastas). Kontrollige sel puhul ka mustusefiltreid, mis asuvad BTC-regulaatori (A) peal. BTC-regulaatori paigaldamise järel kontrollige kindlasti ka väljavoolava vee temperatuuri, nagu kirjeldatud teema "Reguleerimine" all. Vaadake kindlasti enne järele, kas kuum vesi on sisse lülitatud ning kas maksimaalselt kuum vesi on veevõtukohal saadaval.



## Mõõtude (vt lk 66)



## Varuosad (vt lk 68)

XXX = Värvikood  
 000 kroom  
 090 kroom/kuld optik  
 800 roostevaba optik  
 820 brushed nickel  
 830 polished nickel



## Kasutamine (vt lk 70)



## Puhastamine

vt kaasasolevast brošüürist.



## Kontrollsertifikaat (vt lk 67)



## Paigaldamine vt lk 60



Rike	Põhjus	Lahendus
Vähe vett	- Surve ebapiisav	- Kontrollige vee survet torudes (kui pump on installeeritud, kontrollige kas pump töötab)
	- Regulaatori filter on määrdunud	- Puhastage filtrid
	- Duši sõelatihend must	- Puhastage duši ja vooliku vaheline sõelatihend
Ristvool, soe vesi surutakse suletud segisti korral külmaveetoru või vastupidi, kui segisti on suletud	- Tagasilöögiklapp määrdunud/katki	- Tagasilöögiklapp puhastada ja vajadusel välja vahetada
Väljavoolava vee temperatuur ei vasta seatud temperatuurile	- Termostaati pole reguleeritud	- Reguleerige termostaati
	- Sooja vee temperatuur liiga madal	- Tõstke sooja vee temperatuuri 42 °C kuni 65 °C
Termoregulatsioon pole võimalik	- Termoregulaator määrdunud või lupjunud	- Termoregulaator puhastada või vajadusel välja vahetada
	- Uuel paigaldusel põhikorpus valesti ühendatud (peab olema külm paremal, soe vasakul) või 180° pööratud	- Paigaldage funktsiooniblokk 180° pöördega
Ohutusnupp ei tööta	- Vedru on vigastatud või veaga - Gumb je poapnen	- Puhastage ning määrige kergelt vedru või nuppu, vajadusel vahetage ära





## Drošības norādes

- △ Montāžas laikā, lai izvairītos no saspiedumiem un iegriezumiem, nepieciešams nēsāt cimdus.
- △ Šo produktu drīkst izmantot tikai, lai mazgātos, higiēnai un ķermeņa tīrīšanai.
- △ Bērni, kā arī pieaugušie ar fiziskiem, garīgiem un / vai sensoriskiem ierobežojumiem nedrīkst lietot šo produktu bez uzraudzības. Personas, kas atrodas alkohola vai narkotisko vielu iespaidā, nedrīkst lietot šo dušas sistēmu.
- △ Jāizlīdzina spiediena atšķirības starp aukstā un karstā ūdens pievadiem.

## Norādījumi montāžai

Armatūra jāuzstāda, jāizskalo un jāpārbauda atbilstoši spēkā esošajām normām!

## Tehniskie dati

Darba spiediens:	maks. 1 MPa
Ieteicamais darba spiediens:	0,1 – 0,5MPa
Pārbaudes spiediens:	1,6MPa
(1 MPa = 10 bar = 147 PSI)	
Karstā ūdens temperatūra:	maks. 80 °C
Ieteicamā karstā ūdens temperatūra:	65 °C
Caurteces intensitāte pie 0,3 MPa:	apm. 58 l/min
Drošības vārsts	

## Simbolu nozīme



Neizmantojiet silikonu, kas satur etiķskābi!

## max. Drošības funkcija (skat. 62. lpp.) ≈ 42 °C

Pateicoties drošības funkcijai, vēlamo augstāko temperatūru, piem., maks. 42 °C, var iestatīt jau iepriekš.



## Ieregulēšana (skat. 63. lpp.)

Pēc montāžas jāpārbauda termostata iztekas temperatūra. Korektūra ir nepieciešama gadījumā, ja temperatūra iztekas vietā atšķiras no termostatā iestatītās temperatūras.



## Apkope (skat. 64. lpp.)

- Lai nodrošinātu regulatora nevainojamu darbību, termostatu laiku pa laikam jāiestata uz maksimāli aukstu un maksimāli karstu ūdeni.
- Termostats ir aprīkots ar pretvārstu. Regulāri jāpārbauda pretvārsta funkcija saskaņā ar DIN EN 1717 saistībā ar nacionālajiem vai vietējiem noteikumiem (DIN 1988 vienreiz gadā). Pārbaudiet arī filtrus, kas atrodas uz BTC regulatora (A). Pēc BTC regulatora (96633000) montāžas obligāti jāpārbauda ūdens temperatūra pēc principa, kas aprakstīts punktā «Ieregulēšana». Pirms tam obligāti pārbaudiet, vai ir pieslēgta karstā ūdens padeve un vai ūdens padeves vietā ir maksimāla karstā ūdens temperatūra.



## Izmērus (skat. 66. lpp.)



## Rezerves daļas (skat. 68. lpp.)

XXX = Krāsas  
000 hroma  
090 hroma/zelta  
800 tērauda  
820 brushed nickel  
830 polished nickel



## Lietošana (skat. 70. lpp.)



## Tīrīšana

skatiet pievienotajā brošūrā.

## Pārbaudes zīme (skat. 67. lpp.)



## Montāža skat. 60. lpp.









<b>Traucējums</b>	<b>Iemesls</b>	<b>Bojājumu novēršana</b>
Maz ūdens	<ul style="list-style-type: none"> <li>- Problēmas ar ūdens apgādi</li> <li>- Netīrs regulatora filtrs</li> <li>- Netīrs dušas filtra blīvējums</li> </ul>	<ul style="list-style-type: none"> <li>- Pārbaudīt spiedienu ūdenvadā</li> <li>- Tīrīt filtrus</li> <li>- Iztīrīt filtra blīvējumu starp dušu un šūteni</li> </ul>
Ūdens sajaukšanās, karstais ūdens slēgtā stāvoklī tiek spiests aukstā ūdens cauruļvados un otrādi.	<ul style="list-style-type: none"> <li>- Pretvārsts ir netīrs / bojāts</li> </ul>	<ul style="list-style-type: none"> <li>- Tīrīt, nepieciešamības gad. nomainīt pretvārstu</li> </ul>
Ūdens temperatūra nesaskan ar iestatīto temperatūru	<ul style="list-style-type: none"> <li>- Termostats nav pieregulēts</li> <li>- Pārāk zema ūdens temperatūra</li> </ul>	<ul style="list-style-type: none"> <li>- Pieregulēt termostatu</li> <li>- Paaugstināt karstā ūdens temperatūru no 42 °C līdz 65 °C</li> </ul>
Nav iespējama temperatūras regulēšana	<ul style="list-style-type: none"> <li>- Termoregulators ir aizkaļķojies vai netīrs</li> <li>- Jaunas instalācijas gadījumā pamatelements ir nepareizi pieslēgts (jābūt: aukstais ūdens pa labi, karstais pa kreisi) vai ir pārgriezts par 180°.</li> </ul>	<ul style="list-style-type: none"> <li>- Iztīrīt, nepieciešamības gad. nomainīt termoregulatoru</li> <li>- Pagriezt par 180° iekšējo bloku</li> </ul>
Nestrādā sarkanā poga, kas pasargā pret apdedzināšanos	<ul style="list-style-type: none"> <li>- Bojāta atspere</li> <li>- Poga ir aizkaļķojusies</li> </ul>	<ul style="list-style-type: none"> <li>- Iztīrīt un ieeļļot, ja nepieciešams, nomainīt atspēri vai pogu</li> </ul>





## Sigurnosne napomene

-  Prilikom montaže se radi sprečavanja prignječenja i posekotina moraju nositi rukavice.
-  Proizvod sme da se koristi samo za kupanje, tuširanje i ličnu higijenu.
-  Deca, kao i telesno, mentalno i/ili senzorno hendikepirane odrasle osobe ne smeju da koriste proizvod bez nadzora. Osobe koje su pod uticajem alkohola ili droga ne smeju da koriste proizvod.
-  Velika razlika u pritisku između vruće i hladne vode mora biti izbalansirana.

## Instrukcije za montažu

Armatura mora biti postavljena, isprana i testirana prema važećim normama!

## Tehnički podaci

Radni pritisak:	maks. 1 MPa
Preporučeni radni pritisak:	0,1 – 0,5MPa
Probni pritisak:	1,6MPa
(1 MPa = 10 bar = 147 PSI)	
Temperatura vruće vode:	maks. 80°C
Preporučena temperatura vruće vode:	65°C
Protok vode pri pritisku od 0,3 MPa:	oko 58 l/min
Zaštita od povratnog toka	

## Opis simbola



Nemojte koristiti silikon koji sadrži sirćetnu kiselinu!

## max. Safety funkcija (vidi stranu 62)

≈ 42°C

Zahvaljujuću Safety funkciji, može se podesiti željena maksimalna temperatura, npr. maks. 42°C.



## Podešavanje (vidi stranu 63)

Nakon instalacije potrebno je ispitati izlaznu temperaturu termostata. Korekcija je neophodna, ako izmerena temperatura odstupa od temperature koja je nameštena na termostatu.



## Održavanje (vidi stranu 64)

- Kako bi se olakšala prohodnost i produžio vek trajanja regulacione jedinice, potrebno je s vremena na vreme podesiti termostat na položaje za maksimalno toplu i maksimalno hladnu vode.
- Termostat je opremljen nepovratnim ventilom. Ispravno funkcionisanje nepovratnog ventila se mora redovno proveravati prema standardu DIN EN 1717 i u skladu s važećim nacionalnim ili regionalnim propisima (DIN 1988 jednom godišnje). Takođe ispitajte ispravnost hvatača prljavštine koji se nalazi na BTC regulacionoj jedinici. (A). Posle instalacije BTC regulacione jedinice (96633000) obavezno proverite izlaznu temperaturu vode na slavini, kao što je opisano pod tačkom "Podešavanje". Pre toga svakako ispitajte da li je uključen sistem za snabdevanje toplom vodom i izlazi li na probnom mestu voda s maksimalnom temperaturom.



## Mere (vidi stranu 66)



## Rezervni delovi (vidi stranu 68)

XXX = Oznake boja  
 000 hrom  
 090 dezen hrom/zlatna  
 800 dezen plemeniti čelik  
 820 brushed nickel  
 830 polished nickel



## Rukovanje (vidi stranu 70)



## Čišćenje

vidi priloženoj brošuri.



## Ispitni znak (vidi stranu 67)





<b>Smetnja</b>	<b>Uzrok</b>	<b>Pomoć</b>
Nedovoljno vode	<ul style="list-style-type: none"> <li>- Prenizak pritisak vode</li> <li>- Očistite mrežicu za hvatanje prljavštine regulacione jedinice</li> <li>- Mrežasta zaptivka tuša je prljava</li> </ul>	<ul style="list-style-type: none"> <li>- Ispitajte pritisak u cevima</li> <li>- Očistite mrežicu za hvatanje prljavštine ispred termostata i na regulacionoj jedinici</li> <li>- Očistite mrežastu zaptivku između tuša i crijeva</li> </ul>
Ukršteni tok vode, kod zatvorene armature vruća voda ulazi u cev s hladnom vodom i obrnuto	<ul style="list-style-type: none"> <li>- Nepovratni ventil je prljav / neispravan</li> </ul>	<ul style="list-style-type: none"> <li>- Očistite ili, po potrebi, zamenite nepovratni ventil</li> </ul>
Temperatura na slavini se ne podudara s podešenom temperaturom	<ul style="list-style-type: none"> <li>- Termostat nije podešen</li> <li>- Preniska temperatura tople vode</li> </ul>	<ul style="list-style-type: none"> <li>- Podesite termostat</li> <li>- Povećajte temperaturu vruće vode na 42-65 °C</li> </ul>
Regulisanje temperature nije moguće	<ul style="list-style-type: none"> <li>- Regulator temperature je prljav ili obložen naslagama kamenca</li> <li>- Pri ponovnoj instalaciji telo je pogrešno priključeno (potrebno je priključiti hladnu vodu desno, a vruću levo) ili je zakrenuto za 180 stepeni.</li> </ul>	<ul style="list-style-type: none"> <li>- Očistite ili zamenite regulator temperature.</li> <li>- Unutrašnji blok okrenite za 180 stepeni</li> </ul>
Dugme sigurnosnog prekida je van funkcije	<ul style="list-style-type: none"> <li>- Opruga je neispravna</li> <li>- Dugme je začepljeno slojem kamenca</li> </ul>	<ul style="list-style-type: none"> <li>- Očistite i podmažite oprugu, tj. dugme, u slučaju potrebe dugme možete zameniti novim</li> </ul>





## Sikkerhetshenvisninger

- ⚠ Bruk hansker under montasjen for å unngå klem- og kuttskader.
- ⚠ Dusjsystemet skal kun brukes for bade-, hygiene- og kroppshygiene.
- ⚠ Barn og voksne med fysiske og psykiske og/eller sensoriske handicap skal ikke bruke dusjsystemet uten oppsyn. Personer som er påvirket av alkohol eller narkotika skal ikke bruke dusjsystemet.
- ⚠ Store trykkdifferanser mellom kaldt- og varmtvannstilkoblinger skal utlignes.

## Montagehenvisninger

Armaturen skal monteres iht. gyldige standarder. De skal spyles og sjekkes!

## Tekniske data

Driftstrykk	maks. 1 MPa
Anbefalt driftstrykk:	0,1 – 0,5MPa
Prøvetrykk	1,6MPa
(1 MPa = 10 bar = 147 PSI)	
Varmtvannstemperatur	maks. 80 °C
Anbefalt temperatur for varmt vann	65 °C
Gjennomstrømningsytelse ved 0,3 MPa: omtrent 58 l/min	
Egensikker mot tilbakeflyt	

## Symbolbeskrivelse



Ikke bruk silikon som inneholder eddiksyre!

## max. Safety Function (se side 62)

≈ 42 °C

Takket være egenskapen "Safety Function" kan det forhåndsinnstilles en ønsket maks. temperatur, f.eks. 42 °C.



## Justering (se side 63)

Etter avsluttet montering skal termostatens utløpstemperatur kontrolleres. Det er nødvendig med korrektur når temperaturen målt ved uttaksstedet avviker fra temperaturen som er innstilt på termostaten.



## Vedlikehold (se side 64)

- For å holde regulerings-enheten bevegelig, skal termostaten stilles fra tid til annen på helt varmt og helt kaldt.
- Termostaten er utstyrt med returløpssperre. Funksjonen til returløpssperren skal iht. DIN EN 1717 og i samsvar med de nasjonale og lokale forskrifter sjekkes regelmessig (DIN 1988 en gang i året). Ved denne anledningen skal du også sjekke smussfangere som finns på BTC regulerings-enheten (A). Etter montering av BTC regulerings-enheten (96633000) skal utløpstemperaturen absolutt sjekkes som beskrevet under punkt „Justering“. Sjekk i hvert tilfelle at vannforsyningen er slått på og at den maksimale varmtvannstemperaturen ligger opp til tappestedet.



## Mål (se side 66)



## Service deler (se side 68)

XXX = Označe boja  
 000 hrom  
 090 dezen hrom/zlatna  
 800 dezen plemeniti čelik  
 820 brushed nickel  
 830 polished nickel



## Betjening (se side 70)



## Rengjøring

se vedlagt brosjyre.



## Prøvemerket (se side 67)









Feil	Årsak	Feilrettelse
Lite vann	- Forsyningstrykk er ikke tilstrekkelig	- Ledningstrykk sjekkes
	- Smussfangersil til reguleringseheten skitten.	- Smussfangersil rengjøres
	- Dusjens silpakning er skitten	- Silpakning mellom dusj og slangen rengjøres
Krysstrømning, varmt vann presses ved lukket armatur inn i kaldtvannsledning eller omvendt	- Returløpstopper skitten / defekt	- Returløpstopper rengjøres, byttes hvis nødvendig
Utløpstemperatur samsvarer ikke med innstilt temperatur	- Termostat ble ikke justert	- Termostat justeres
	- For lav varmtvannstemperatur	- Varmtvannstemperatur økes til mellom 42 °C og 65 °C
Temperaturregulering er ikke mulig	- Reguleringsenhet for temperatur er skitten eller forkalket	- Reguleringsenhet for temperatur rengjøres og byttes hvis nødvendig
	- Ved nyinstallasjon: basiselement feilaktig tilkoblet (riktig: kaldt høyre, varmt venstre) eller bygd inn 180° forvrent	- Funksjonsblokk bygges inn 180° forvrent
Trykknapp til sikkerhetssperren uten funksjon	- Fjær defekt - Kalk på trykknapp	- Fjær hhv. Trykknapp rengjøres og smøres lett inn, byttes hvis nødvendig





## **Указания за безопасност**

-  При монтажа трябва да се носят ръкавици, за да се избегнат наранявания поради притискане или порязване.
-  Позволено е използването на продукта само за къпане, хигиена и цели на почистване на тялото.
-  Не е позволено деца, както и възрастни с физически, умствени и / или сензорни ограничения да използват продукта без надзор. Не е позволено използването на системата на продукта от лица, употребили алкохол или дрога.
-  Големите разлики в налягането между изводите за студената и топлата вода трябва да се изравняват.

## **Указания за монтаж**

Арматурата трябва да се монтира, промие и провери в съответствие с валидните норми!

## **Технически данни**

Работно налягане:	макс. 1 МПа
Препоръчително работно налягане:	0,1 – 0,5МПа
Контролно налягане:	1,6МПа
(1 МПа = 10 bar = 147 PSI)	
Температура на горещата вода:	макс. 80 °С
Препоръчителна температура на горещата вода:	65 °С
Мощност на потока при 0,3 МПа:	прибл. 58 л/мин
Самозащитен против обратно изтичане	

## **Описание на символите**



Не използвайте силикон, съдържащ оцетна киселина!

**max. Safety Function** (Функция за безопасност) (вижте стр. 62)

Благодарение на Safety Function (функция за безопасност) желаната максимална температура може да се настрои предварително напр. на макс. 42 °С.



**Юстиране** (вижте стр. 63)

След извършен монтаж трябва да се провери температурата на крайника на термостата. Ако измерената температура на мястото на водоземане се различава от настроената на термостата температура, е необходима корекция.



**Поддръжка** (вижте стр. 64)

- За да се гарантира лекоподвижността на регулиращото звено, от време на време термостатът трябва да се поставя на максимално топло и на максимално студено.
- Термостатът е оборудван с предпазител за обратен поток. Съгласно DIN EN 1717 редовно трябва да се проверява функционирането на приспособленията за предотвратяване на обратния поток в съответствие с националните или регионални изисквания (DIN 1988 веднъж годишно). При тази възможност проверявайте и уловителите на мръсотия, които се намират на регулиращия елемент ВТС (А). След монтажа на регулиращото звено ВТС (96633000) непременно проверете температурата на изхода, както е описано в точка „Настройка“. Непременно проверете предварително, дали захранването с топла вода е включено и дали на мястото на източване е налична макс. температура на топлата вода.



**Размери** (вижте стр. 66)



**Сервизни части** (вижте стр. 68)

XXX = Označe boja  
 000 hrom  
 090 dezen hrom/zlatna  
 800 dezen plemeniti čelik  
 820 brushed nickel  
 830 polished nickel

**Обслужване** (вижте стр. 70)



**Почистване**

от приложената брошура.



**Контролен знак** (вижте стр. 67)





Неизправност	Причина	Помощ
Малко вода	- Захранващото налягане не е достатъчно	- Проверете налягането на тръбопровода
	- Цедката за улавяне на замърсяванията на регулиращия елемент е замърсена	- Почистване на цедката за улавяне на замърсяванията
	- Замърсено е уплътнението с цедка на разпръсквателя	- Почистете уплътнението с цедка между разпръсквателя и маркуча
Кръстосване на потока, при затворена арматура топлата вода навлиза в линията на студената вода или обратно	- Замърсено / дефектно приспособление за предотвратяване на обратния поток	- Почистете респ. сменете приспособлението за предотвратяване на обратния поток
Изходящата температура не съвпада с настроената температура	- Термостатът не е юстиран	- Юстиране на термостата
	- Твърде ниска температура на водата	- Повишете ограничението за топлата вода на 42 °C до 65 °C
Не е възможно регулиране на температурата	- Приспособлението за регулиране на температурата е замърсено или покрито с варовик	- Почистете респ. сменете приспособлението за регулиране на температурата
	- При нова инсталация основното тяло е свързано погрешно (Зад.: студено отдясно, топло отляво или монтирайте със завъртане от 180°	- Монтирайте функционалния блок със завъртане на 180°
Копчето на предпазната блокировка не функционира	- Дефектна пружина	- Почистете пружината респ.
	- Копчето е покрито с варовик	копчето и ги смажете леко, при необх. ги сменете





## Udhëzime sigurie

- △ Për të evituar lëndimet e pickimeve ose të prerjeve gjatë procesit të montimit duhet që të vishni doreza.
- △ Produkti duhet të përdoret vetëm qëllimet e banjave, të higjienës dhe të larjes së trupit.
- △ Fëmijët dhe të rriturit me aftësi të kufizuara fizike, mendore dhe/ose ndijuese nuk duhet ta përdorin produktin pa qenë nën mbikëqyrje. Personat që janë nën ndikimin e drogave ose të alkoolit nuk duhet ta përdorin produktin.
- △ Ndryshimet e mëdha të presionit mes lidhjeve të ujit të ftohtë dhe atij të ngrohtë duhen ekuilibruar.

## Udhëzime për montimin

Armatura duhet montuar, shpërlarë dhe kontrolluar në bazë të normave të vlefshme!

### Të dhëna teknike

Presioni gjatë punës	maks. 1 MPa
Presioni i rekomanduar:	0,1 - 0,5MPa
Presioni për provë:	1,6MPa
(1 MPa = 10 bar = 147 PSI)	
Temperatura e ujit të ngrohtë	maks. 80 °C
Temperatura e rekomanduar e ujit të ngrohtë:	65 °C
Kapaciteti i rrjedhjes në 0,3 MPa:	afro 58 l/min
Siguresa kundër rrjedhjes në drejtim të kundërt	

## Përshkrimi i simbolit



Mos përdorni silikon që në përbërje ka acid acetik.

## max. **Funksionet e sigurisë** (shih faqen ≈ 42 °C 62)

Falë Safety Function mund të përcaktohet temperatura maksimale e dëshiruar, p.sh. 42 °C.



## Justimi (shih faqen 63)

Pas montimit duhet kontrolluar temperatura në dalje e termostatit. Korrigjimet janë të nevojshme, nëse temperatura e matur në pikën e rrjedhjes së ujit nuk është e njëjtë me temperaturën e përcaktuar në termostat.



## Mirëmbajtja (shih faqen 64)

- Për të lehtësuar përdorimin e njësisë rregulluese, termostati do të duhej çuar herë pas here nga shumë i ngrohtë në shumë të ftohtë.
- Termostati është i pajisur me pengues të rrjedhjes në drejtim të kundërt. Penguesit e rrjedhjes në drejtim të kundërt duhen kontrolluar rregullisht në bazë të normave nacionale dhe regjionale (DIN 1988 një herë në vit). Kontrolloni me këtë rast edhe mbledhësit e papastërtive të cilët ndodhen në njësinë rregulluese BTC (A). Pas montimit të njësisë rregulluese BTC kontrolloni patjetër temperaturën në dalje, siç e kemi përshkruar në pikën "justimi". Para kësaj kontrolloni patjetër se a është i ndezur furnizimi me ujë të ngrohtë dhe a është caktuar temperatura maksimale në pikën nga del uji i ngrohtë.



## Përmasat (shih faqen 66)



## Pjesë ndërrimi (shih faqen 68)

XXX = Oznake boja  
 000 hrom  
 090 dezen hrom/zlatna  
 800 dezen plemeniti çelik  
 820 brushed nickel  
 830 polished nickel



## Përdorimi (shih faqen 70)



## Pastrimi

shikoni broshurën bashkëngjitur.

## Shenja e kontrollit (shih faqen 67)







<b>Demtim</b>	<b>Shkaku</b>	<b>Ndihme</b>
Pak ujë	- Presioni ushqyes jo limjaftueshem - Sita qe mbledh papastertite tek njesia rregulluese eshte me papasterti - Gomina hermetizuese e pajisjes me papasterti	- Kontrolloni presionin e tubacionit - Pastroni siten qe mbledh papastertite - Pastroni gominen e sites midis pajisjes dhe tubit
Rrjedhje e kryqezuar, uji i ngrohte do te cohet tek tubacioni i ujit te ftohte kur armatura eshte e mbyllur ose anasjelltas	- Penguesi i rrjedhjes mbrapsht te ujit me papasterti ose me defekt	- Pastroni ose kembeni penguesinn e rrjedhjes mbrapsht te ujit
Temperatura reale nuk perputhet me temperaturen e regjistruar	- Termostati nuk eshte rregulluar - Temperaturë e ulët e ujit të ngrohtë	- Rregulloni termostatin - Rrisni temperaturen e ujit te ngrohte nga 42 °C deri 65 °C
Rregullimi i temperatures nuk eshte i mundur	- Njesia rregulluese e temperatures me papasterti ose me kalk - Tek instalimi i ri karkasa baze eshte lidhur gabim(Duhet: ftohte djathtas, ngrohte majtas) ose eshte montuar 180grade ndryshe	- Pastroni ose kembeni njesine rregulluese te temperatures - Montoni bllokun e funksioneve ne 180 grade mbrapsht
Butoni i bllokuesit te sigurise pa funksion	- Susta me defekt - Butoni me kalk	- Pastroni butonin ose susten dhe grasatojeni pak, ose nderrojeni





العطل	السبب	العلاج والإصلاح
الماء غير كافٍ	- ضغط الإمداد ليس كافيًا	- افحص ضغط المواسير
تدفق منعكس للمياه! الماء الساخن يندفع في ماسورة البارد أو العكس والخلاط مغلق.	- صمام منع الرجوع متسخ / تالف	- قم بتنظيف مرشح الاتساخات
حرارة المياه لا تتوافق مع درجة الحرارة المضبوطة	- لم يتم ضبط الثرموستات	- نظف سداة المصفاة بين الدش والخرطوم
تنظيم الحرارة غير ممكن	- درجة حرارة الماء الساخن منخفضة للغاية	- قم بتنظيف صمام منع الرجوع أو تغييره إذا لزم الأمر
زر الضغط الخاص بقفل الأمان لا يعمل	- تركيب الجزء الرئيسي من الخلات بشكل خاطيء (ينبغي أن يكون البارد يمينًا، والساخن يسارًا) أو تم عكسه 180 درجة	- اضبط الثرموستات
	- تنظيم الحرارة متسخ أو عليه جير	- ارفع حد الماء الساخن إلى 42°-65° درجة مئوية
	- تم تركيب الجزء الرئيسي من الخلات بشكل خاطيء (ينبغي أن يكون البارد يمينًا، والساخن يسارًا) أو تم عكسه 180 درجة	- قم بتنظيف منظم الحرارة أو تغييره إذا لزم الأمر
	- الياي تالف - هناك جير على زر الضغط	- قم بتنظيف الياي أو زر الضغط مع تشحيمهما بشكل خفيف، أو قم بتغييرهما إذا لزم الأمر



## تنبيهات الأمان



- ⚠ يجب ارتداء قفازات اليد أثناء التركيب لتجنب حدوث أخطار الإنحشار أو الجروح.
- ⚠ لا يجب استخدام نظام الدش إلا في أغراض الاستحمام والأغراض الصحية وأغراض تنظيف الجسم.
- ⚠ لا يسمح لأي أطفال أو أفراد بالغين يعانون من إعاقات بدنية أو ذهنية أو حسية أو يعانون من جميع هذه الإعاقات باستخدام المنتج إلا تحت إشراف آخرين. كما أنه لا يسمح لأي شخص تحت تأثير تناول الكحول أو المخدرات باستخدام نظام الدش.
- ⚠ يجب أن يكون تيار الماء الساخن والماء البارد متعادلين في الضغط.

## تعليمات التركيب

يجب تركيب الوصلة، وغمرها بالماء واختبارها وفقاً للمعايير السارية!

## المواصفات الفنية

- ضغط التشغيل: الحد الأقصى 1 ميجاباسكال
- ضغط التشغيل الموصى به: 0,1 - 0,5 ميجاباسكال
- ضغط الاختبار: 1,6 ميجاباسكال
- (1 ميجاباسكال = 10 بار = 147 PSI)
- درجة حرارة الماء الساخن: الحد الأقصى 80°C
- درجة الحرارة الموصى بها للماء الساخن: 65°C
- معدل التدفق عند ضغط 0,3 ميجاباسكال: تقريباً 58 لتر / الدقيقة
- خاصية عدم التدفق العكسي

## وصف الرمز

هام! لا تستخدم السليكون الذي يحتوي على أحماض!



## max. وظيفة الأمان (راجع صفحة 62)

≈ 42°C

يمكن إجراء ضبط مسبق للحد الأقصى لدرجة الحرارة المرغوبة، على سبيل المثال بحد أقصى 42° بفضل وظيفة الأمان.

## الضبط (راجع صفحة 63)

بعد التركيب يجب فحص درجة حرارة الترموستات. يلزم إجراء تصحيح إذا اختلفت درجة الحرارة المقاسة عند موقع القياس عن درجة حرارة الترموستات.



## الصيانة (راجع صفحة 64)



- لضمان التشغيل السلس للترموستات، من الضروري تحويله من وقت إلى آخر من أقصى سخونة إلى أقصى البرودة.
- الخلاط مزود بصمامات عدم الرجوع يجب فحص صمام عدم الرجوع بصفة منتظمة حسب المواصفة DIN EN 1717 وذلك طبقاً للوائح الوطنية أو الإقليمية (مرة واحد سنوياً طبقاً للمواصفة DIN 1988). في الوقت الحالي، الرجاء أيضاً فحص المرشح الموجود فوق المقياس الحراري BTC (A). بعد تركيب منظم الحرارة BTC (96633000)، من الضروري فحص حرارة المياه عند نقطة الخروج الموضحة ضمن المعلومات الموجودة أسفل العنوان "الضبط". قبل إجراء الضبط، الرجاء التحقق من استخدام مصدر المياه الساخنة وبلوغ الماء درجة الحرارة القصوى عند نقطة الخروج.

## أبعاد (راجع صفحة 66)



## قطع الغيار (راجع صفحة 68)

- XXX = الألوان
- 000 كروم
- 090 كروم/لون ذهبي
- 800 مظهر الإستانليس ستيل
- 820 نيكل مُفَرَّش
- 830 نيكل مصقول



## التشغيل (راجع صفحة 70)



## التنظيف

راجع والكتيب المرفق



## شهادة اختبار (راجع صفحة 67)



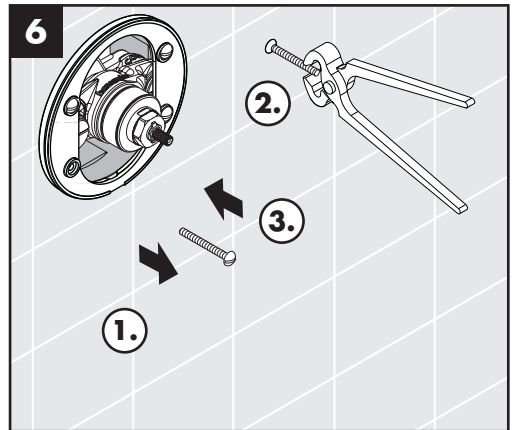
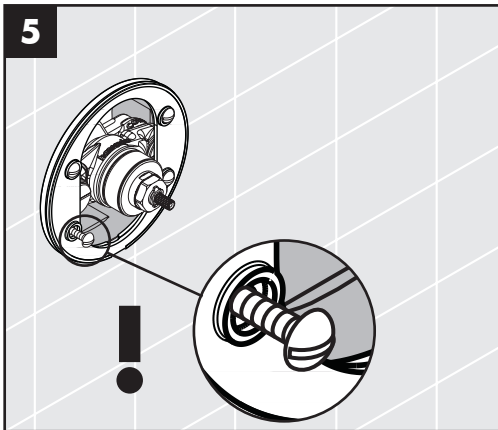
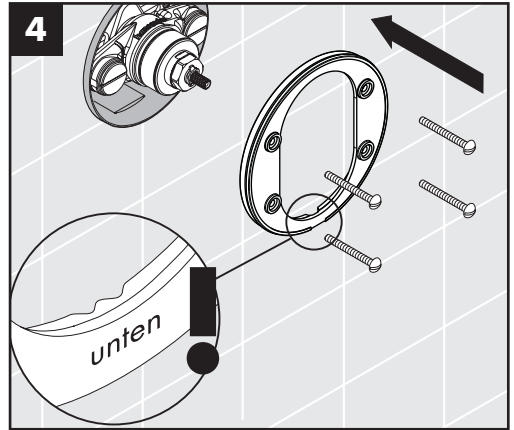
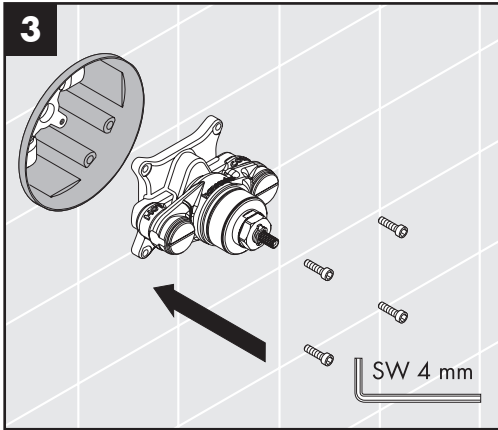
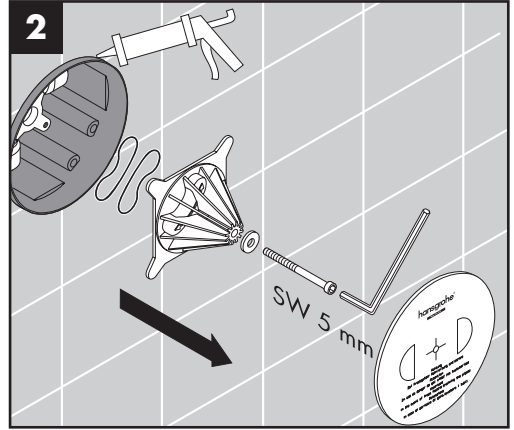
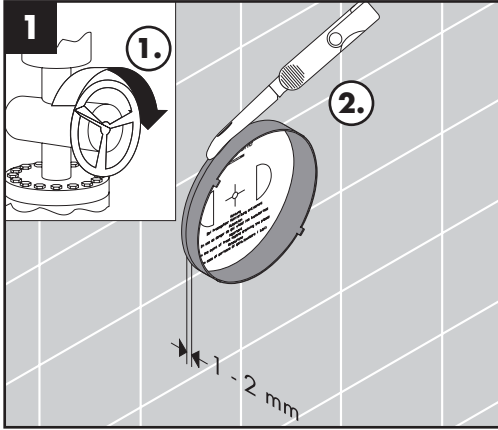



**7a**

**Starck / StarckX /  
Montreux / Carlton /  
CitterioM / Steel /  
Terrano / Uno /  
Citterio**

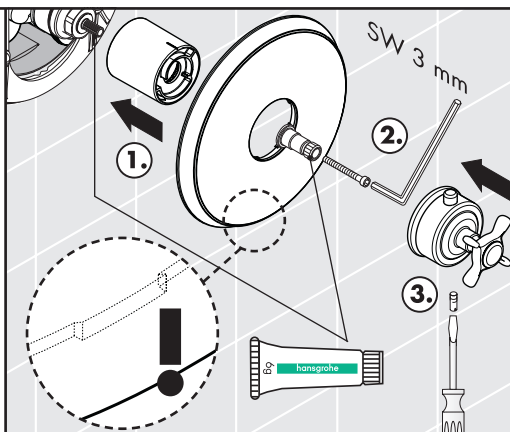

**7b**

**Massaud / Bouroullec**

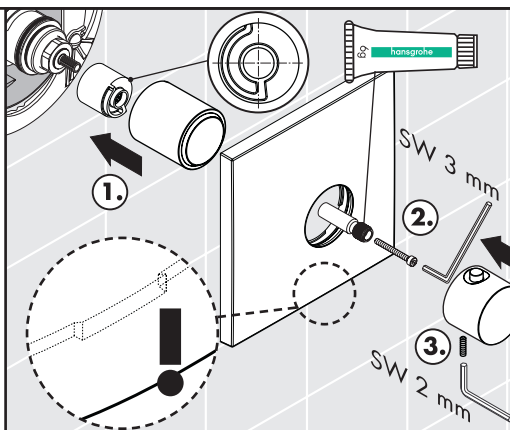

max.  
≈ 42 °C

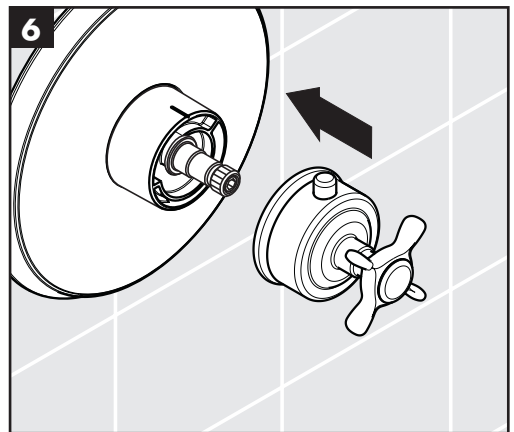
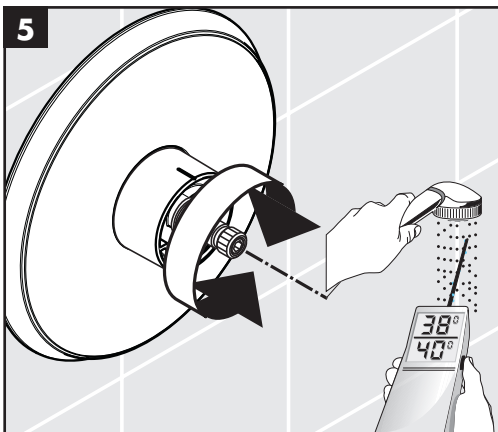
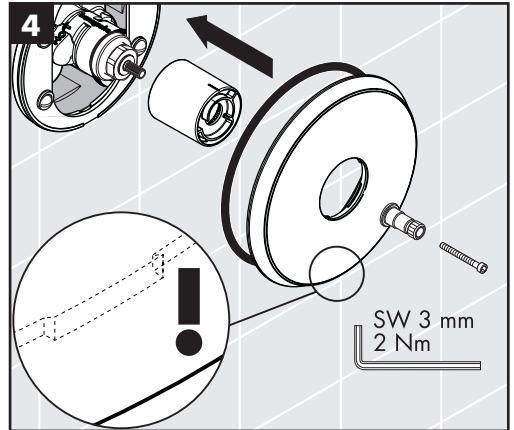
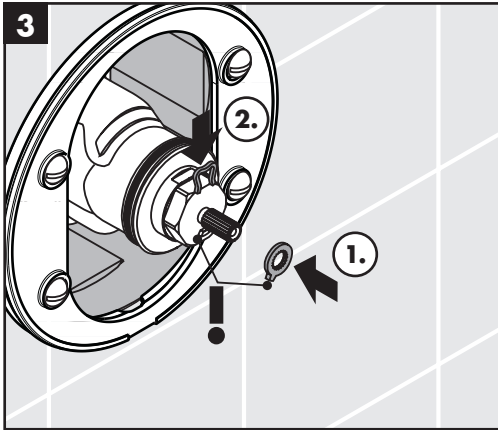
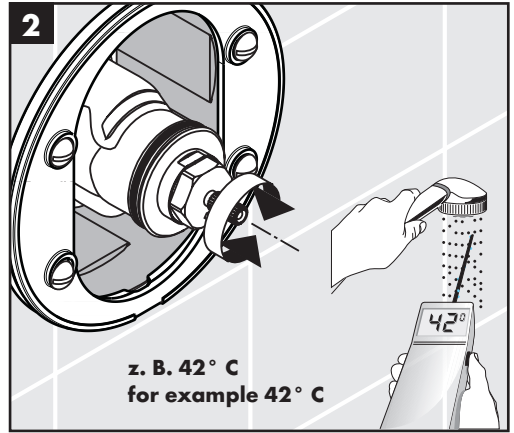
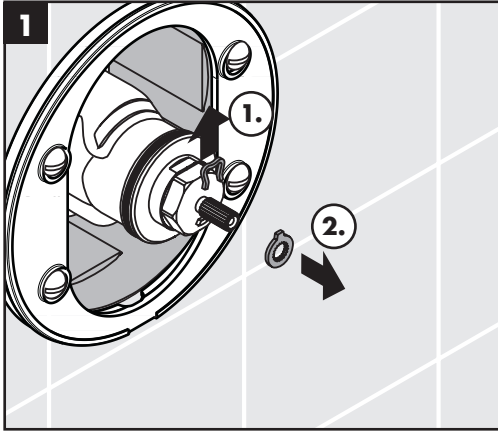

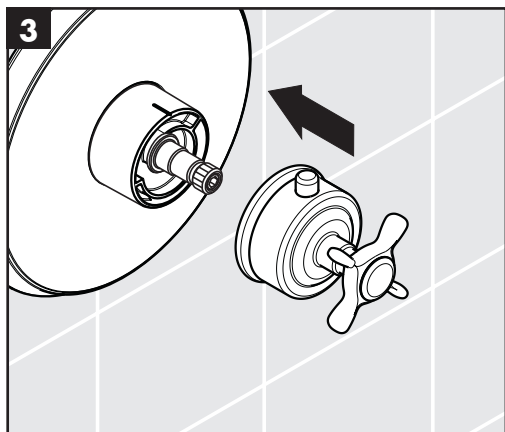
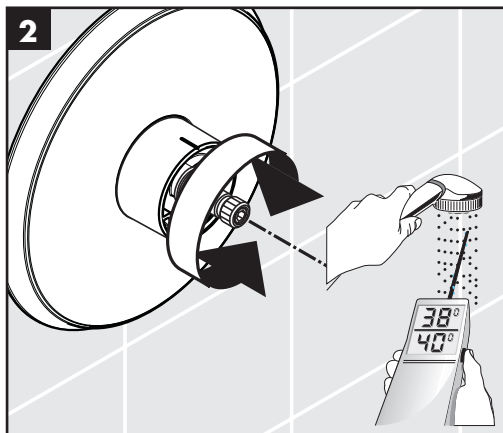
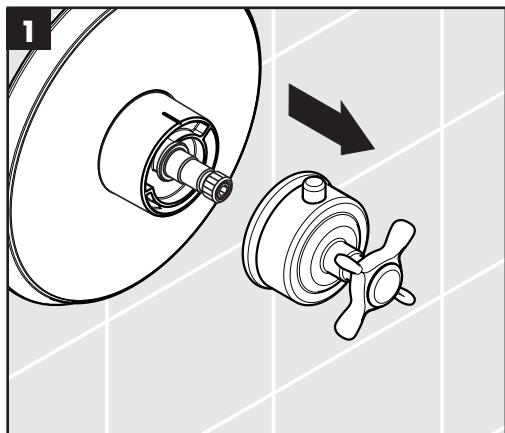

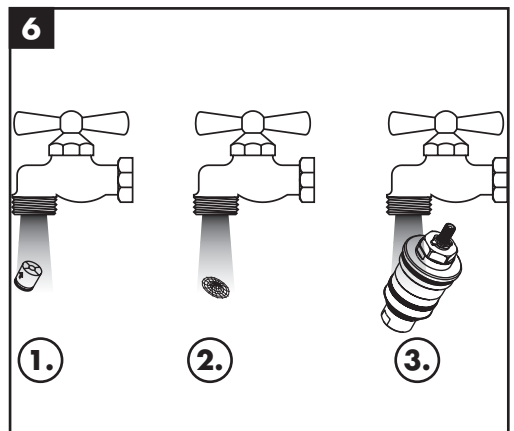
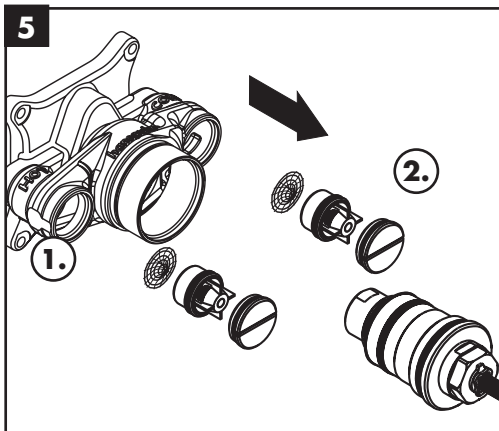
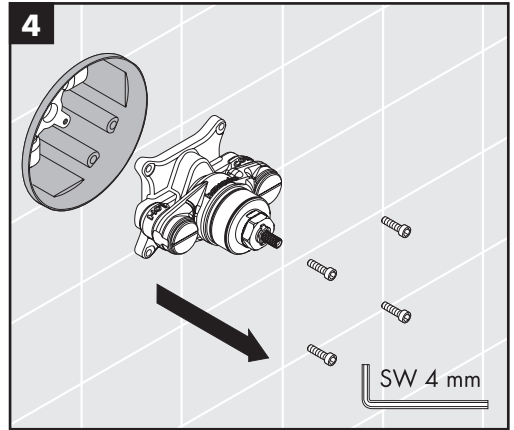
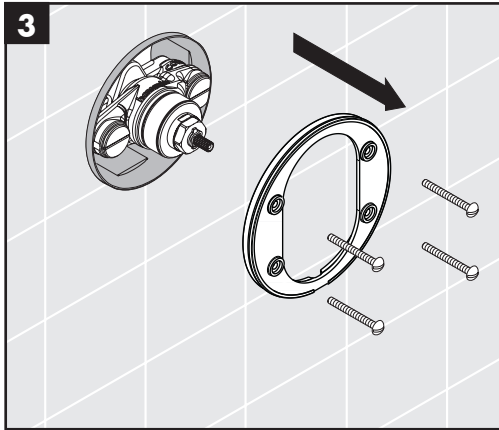
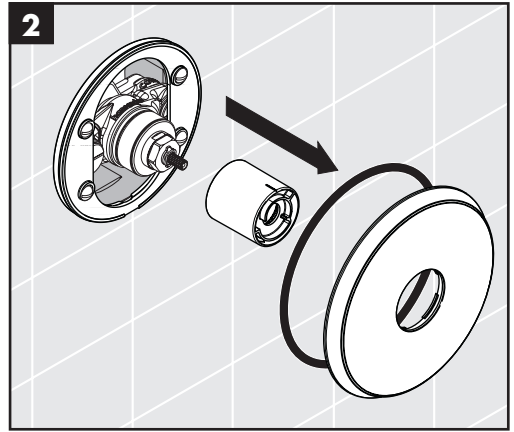
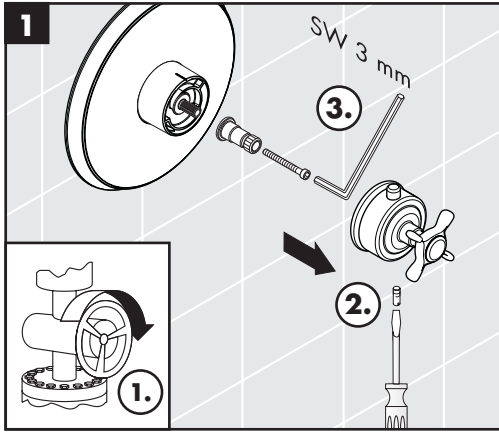



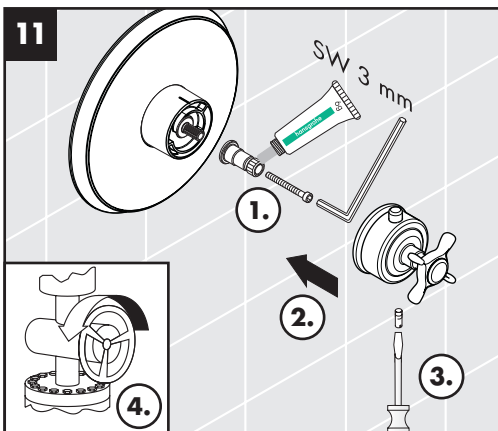
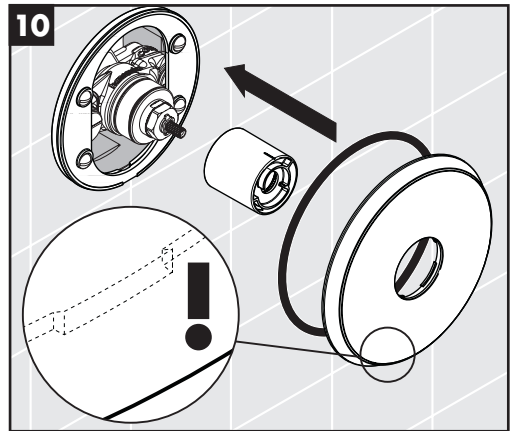
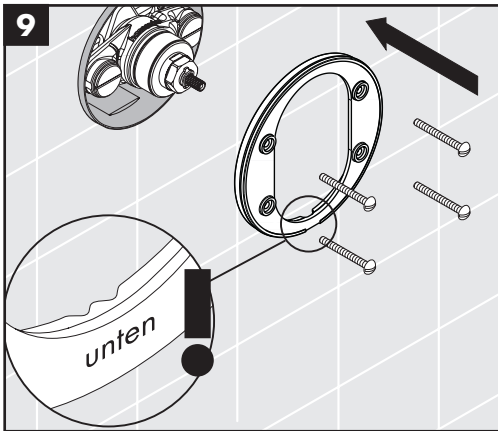
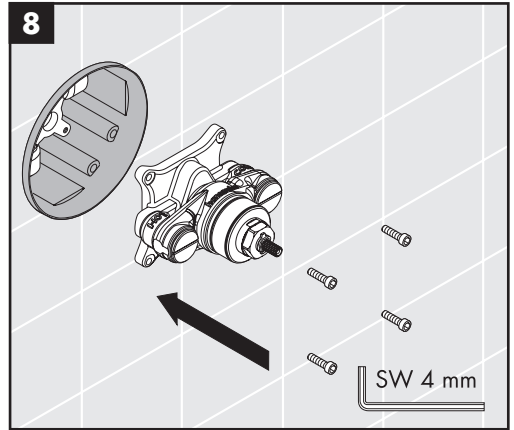
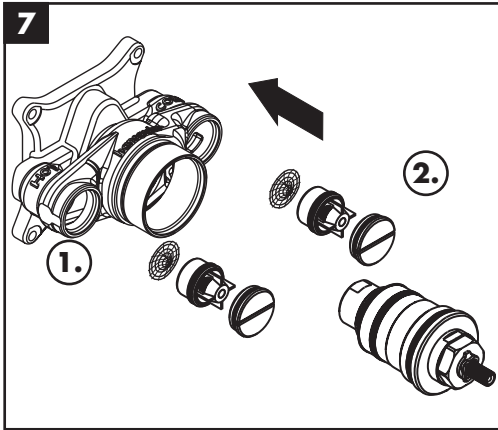

**Starck**

10715000

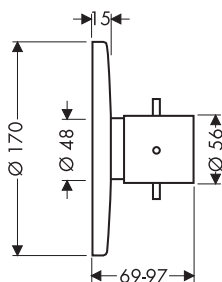
**Starck X**

10717000

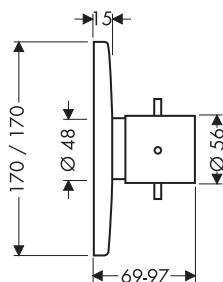
**Montreux**

16815XXX

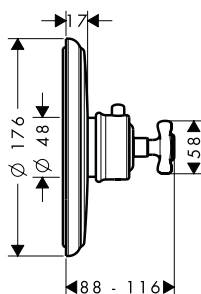
**Carlton**

17712XXX

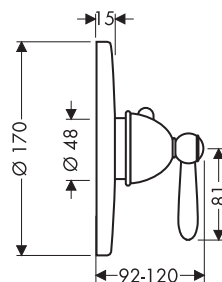
**Carlton**

17716XXX

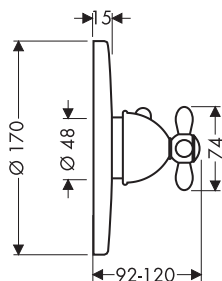
**Massaud**

18741000

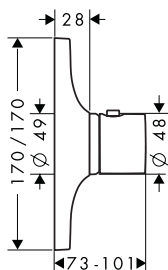
**Citterio M**

34716000

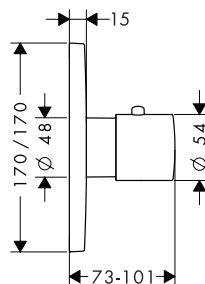
**Steel**

35715800

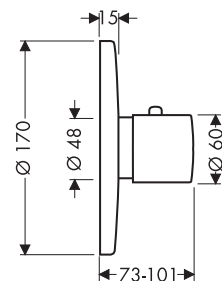
**Terrano**

37711000

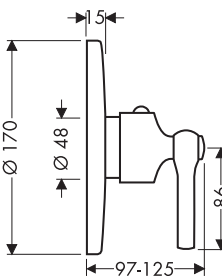
**Terrano**

37716000

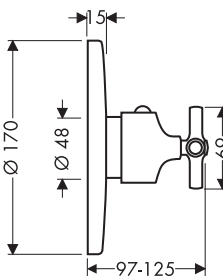
**Uno**

38715000

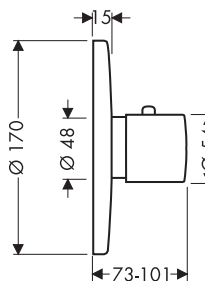
**Citterio**

39711000

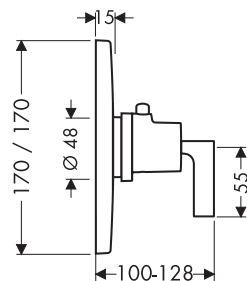

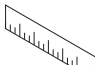

**Citterio**

39716000

**Bouroullec**

19702000

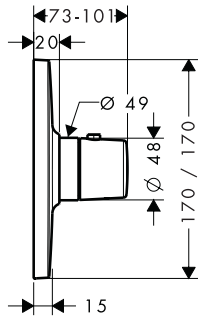
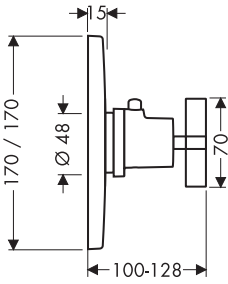

	PA-IX	DVGW	SVGW	ACS	WRAS	NF	KIWA
<b>10715000</b>	18019/II	BQ0587	X	X	X	X	X
<b>10717000</b>	18019/II	BQ0587	X	X	X	X	X
<b>16815XXX</b>	18019/II	BQ0587	X	X	X	X	X
<b>17712XXX</b>	18019/II	BQ0587	X	X	X	X	X
<b>17716XXX</b>	18019/II	BQ0587	X	X	X	X	X
<b>18741000</b>	18019/II	BQ0587	X	X	X	X	X
<b>35715800</b>	18019/II	BQ0587	X	X	X	X	X
<b>34716000</b>	18019/II	BQ0587			X	X	
<b>37711000</b>	18019/II	BQ0587	X	X	X	X	X
<b>37716000</b>	18019/II	BQ0587	X	X	X	X	X
<b>38715000</b>	18019/II	BQ0587	X	X	X	X	X
<b>39711000</b>	18019/II	BQ0587	X	X	X	X	X
<b>39716000</b>	18019/II	BQ0587	X	X	X	X	X
<b>19702000</b>					X		



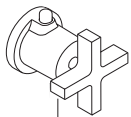
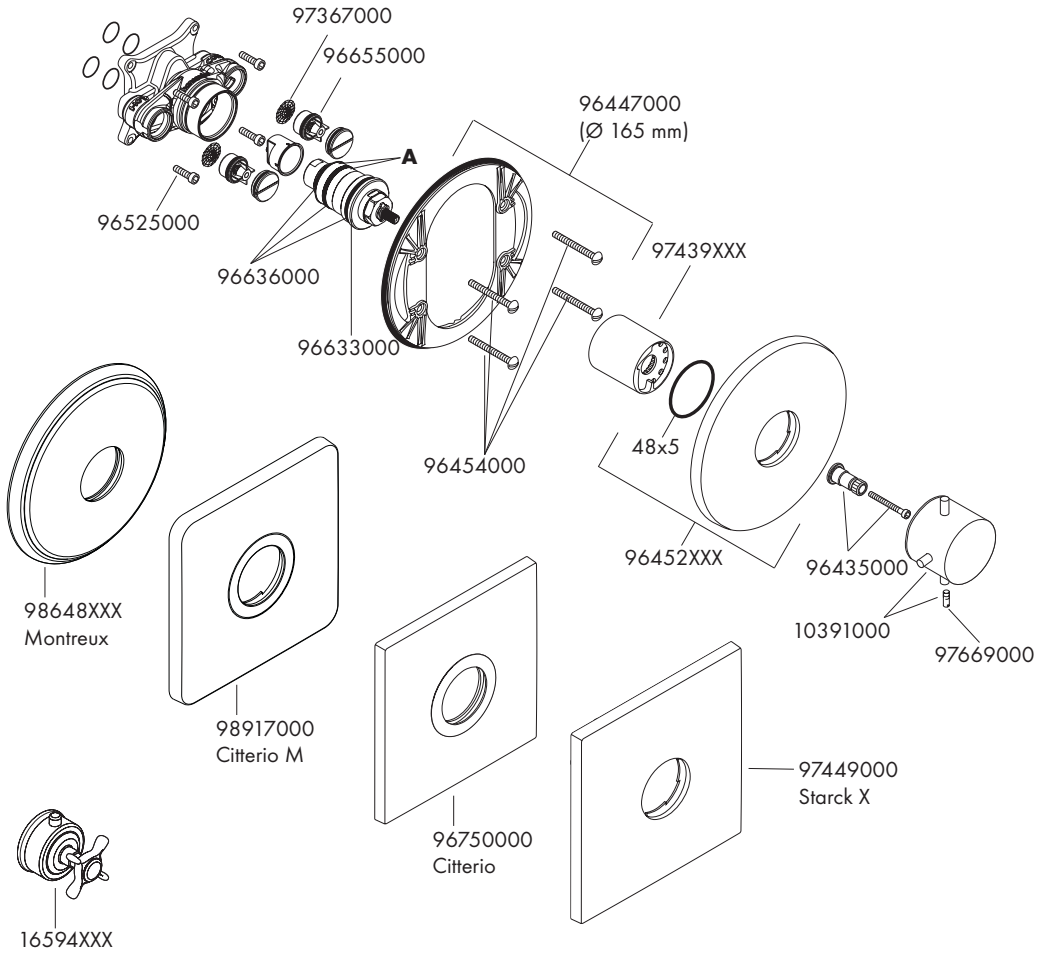

39391000



39994000

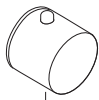

38391000

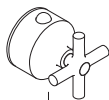

37994000



37391000

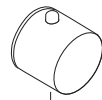

35391800



17391XXX

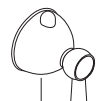

17391XXX

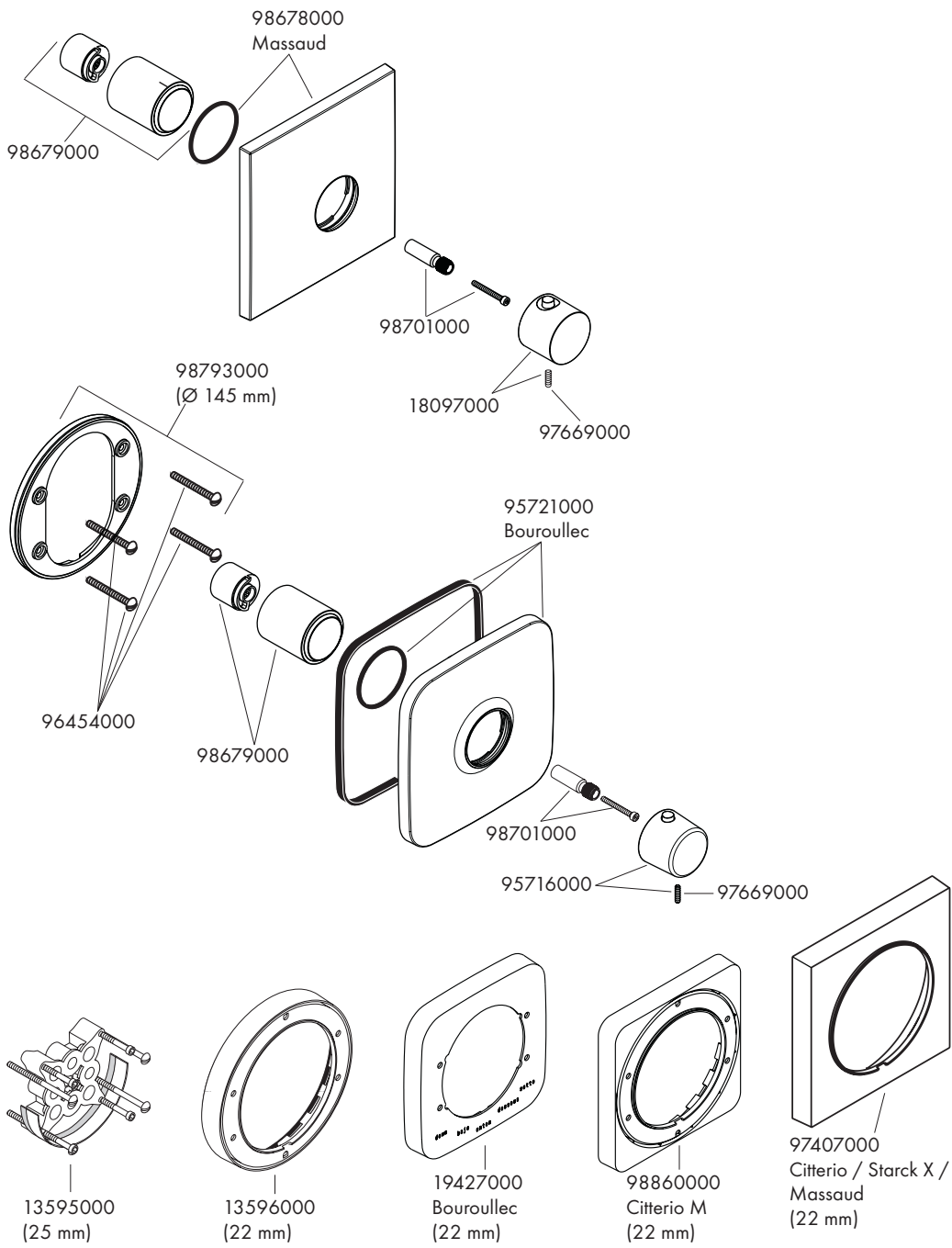

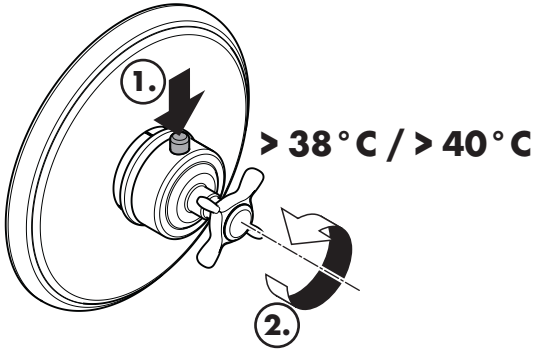



---

**hansgrohe**

Hansgrohe · Postfach 1145 · D-77761 Schiltach · Telefon +49 (0) 78 36/51-1282 · Telefax +49 (0) 7836/511440  
E-Mail: [info@hansgrohe.com](mailto:info@hansgrohe.com) · Internet: [www.hansgrohe.com](http://www.hansgrohe.com)

9/2010  
9.05277.07