

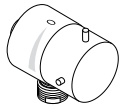

AXOR®

hansgrohe

DE	Gebrauchsanleitung / Montageanleitung	2		
FR	Mode d'emploi / Instructions de montage	2		
EN	Instructions for use / assembly instructions	3		
IT	Istruzioni per l'uso / Istruzioni per Installazione	3		
ES	Modo de empleo / Instrucciones de montaje	4		
NL	Gebruiksaanwijzing / Handleiding	4		
DK	Brugsanvisning / Monteringsvejledning	5		
PT	Instruções para uso / Manual de Instalação	5		
PL	Instrukcja obsługi / Instrukcja montażu	6		
CS	Návod k použití / Montážní návod	6		
SK	Návod na použitie / Montážny návod	7		
ZH	用户手册 / 组装说明	7		
RU	Руководство пользователя / Инструкция по монтажу	8		
HU	Használati útmutató / Szerelési útmutató	8		
FI	Käyttöohje / Asennusohje	9		
SV	Brugsanvisning / Monteringsanvisning	9		
LT	Vartotojo instrukcija / Montavimo instrukcijos	10		
HR	Upute za uporabu / Uputstva za instalaciju	10		
TR	Kullanım kılavuzu / Montaj kılavuzu	11		
RO	Manual de utilizare / Instrucțiuni de montare	11		
EL	Οδηγίες χρήσης / Οδηγία συναρμολόγησης	12		
SL	Navodilo za uporabo / Navodila za montažo	12		
ET	Kasutusjuhend / Paigaldusjuhend	13		
LV	Lietošanas pamācība / Montāžas instrukcija	13		
SR	Uputstvo za upotrebu / Uputstvo za montažu	14		
NO	Brugsanvisning / Montasjeveiledning	14		
BG	Инструкция за употреба / Инструкция за употреба	15		
SQ	Udhëzuesi i përdorimit / Udhëzime rreth montimit	15		
AR	دليل الاستخدام / تعليمات التجميع	16		
				
			Starck 10882XXX	Montreux 16882XXX
				
			Carlton 17882XXX	Carlton 17883XXX
				
			Steel 35882800	
				
			Terrano 37882XXX	Terrano 37883XXX
				
			Uno 38882XXX	
				
			Citterio 39882XXX	Citterio 39883XXX

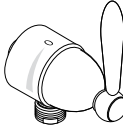
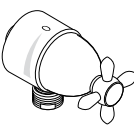
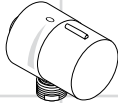
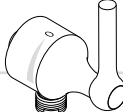
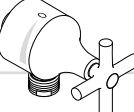
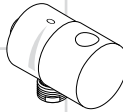
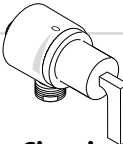
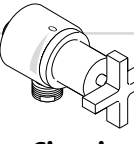

Sicherheitshinweise

- Bei der Montage müssen zur Vermeidung von Quetsch- und Schnittverletzungen Handschuhe getragen werden.

Symbolerklärung



Kein essigsäurehaltiges Silikon verwenden!



Maße (siehe Seite 17)



Bedienung (siehe Seite 18)



Wartung (siehe Seite 19)

Rückflussverhinderer müssen gemäß DIN EN 1717 regelmäßig in Übereinstimmung mit nationalen oder regionalen Bestimmungen (DIN 1988 einmal jährlich) auf ihre Funktion geprüft werden.
Eigensicher gegen Rückfließen



Reinigung

Reinigungsempfehlung siehe beiliegende Broschüre.



Serviceteile (siehe Seite 20)

XXX = Farbcodierung
000 = chrom
090 = chrom/gold-optik
120 = chrom/Porzellan
820 = brushed nickel
830 = polished nickel

Consignes de sécurité

- Lors du montage, porter des gants de protection pour éviter toute blessure par écrasement ou coupure

Description du symbole



Ne pas utiliser de silicone contenant de l'acide acétique!



Dimensions (voir page 17)



Instructions de service (voir page 18)



Entretien (voir page 19)

Les clapets anti-retour doivent être examinés régulièrement conformément à la norme EN 1717 ou conformément aux dispositions nationales ou régionales quant à leur fonction (au moins une fois par an).
Avec dispositif anti-retour



Nettoyage

Pour les conseils d'entretien, voir la brochure ci-jointe.



Pièces détachées (voir pages 20)

XXX = Couleurs
000 = chromé
090 = chromé/or l'optique
120 = chrome plated/porcelain colour
820 = brushed nickel
830 = polished nickel



Prüfzeichen (siehe Seite 21)



Classification acoustique et débit (voir pages 21)

Montage
siehe Seite 16



Montage
voir pages 16

**! Safety Notes**

- ⚠ Gloves should be worn during installation to prevent crushing and cutting injuries.

Symbol description

Do not use silicone containing acetic acid!



Dimensions (see page 17)



Operation (see page 18)



Maintenance (see page 19)

The non return valves must be checked regularly according to DIN EN 1717 in accordance with national or regional regulations (at least once a year).
anti-pollution function

**Cleaning**

Cleaning recommendations, see enclosed brochure.



Spare parts (see page 20)

XXX = Colors
000 = chrome plated
090 = chrome plated/gold plated
120 = chrome plated/porcelain colour
820 = brushed nickel
830 = polished nickel



Test certificate (see page 21)

Assembly
see page 16

**! Indicazioni sulla sicurezza**

- ⚠ Durante il montaggio, per evitare ferite da schiacciamento e da taglio bisogna indossare guanti protettivi.

Descrizione simbolo

Non utilizzare silicone contenente acido acetico!



Ingombri (vedi pagg. 17)



Procedura (vedi pagg. 18)



Manutenzione (vedi pagg. 19)

La valvola di non ritorno deve essere controllata regolarmente come da DIN EN 1717, secondo le normative nazionali e regionali (almeno una volta all'anno).
Sicurezza antiriflusso

**Pulitura**

Suggerimenti per la pulizia: vedi il prospetto incluso.



Parti di ricambio (vedi pagg. 20)

XXX = Trattamento
000 = cromato
090 = cromo/dorato ottica
120 = cromo/porcellana
820 = brushed nickel
830 = polished nickel



Segno di verifica (vedi pagg. 21)

Montaggio
vedi pagg. 16



Indicaciones de seguridad

 Durante el montaje deben utilizarse guantes para evitar heridas por aplastamiento o corte.

Veiligheidsinstructies

 Bij de montage moeten ter voorkoming van knel- en snijwonden handschoenen worden gedragen.

Descripción de símbolos



No utilizar silicona que contiene ácido acético!



Gebruik geen zuurhoudende silicone!



Dimensiones (ver página 17)



Maten (zie blz. 17)



Manejo (ver página 18)



Bediening (zie blz. 18)



Mantenimiento (ver página 19)



Onderhoud (zie blz. 19)

Las válvulas anti-retorno tienen que ser controladas regularmente según la norma DIN EN 1717, en acuerdo con las regulaciones nacionales o regionales (una vez al año, por lo menos).
Seguro contra el retorno

Keerkleppen moeten volgens DIN EN 1717 regelmatig en volgens plaatselijk geldende eisen op het functioneren gecontroleerd worden. (Tenminste een keer per jaar).
Beveiligd tegen terugstromen



Limpiar

Para las instrucciones de limpieza, ver el folleto adjunto.



Reinigen

Reinigingsadvies zie bijgevoegde brochure.



Repuestos (ver página 20)

XXX = Acabados
000 = cromado
090 = cromo/oro óptica
120 = cromo/color porcelana
820 = brushed nickel
830 = polished nickel



Service onderdelen (zie blz. 20)

XXX = Kleuren
000 = verchromd
090 = chroom/verguld-look
120 = chroom/porselein
820 = brushed nickel
830 = polished nickel



Marca de verificación (ver página 21)



Keurmerk (zie blz. 21)

Montaje
ver página 16



Montage
zie blz. 16



! Sikkerhedsanvisninger

⚠ Ved monteringen skal der bruges handsker for at undgå kvæstelser og snitsår.

! Avisos de segurança

⚠ Durante a montagem devem ser utilizadas luvas de protecção, de modo a evitar ferimentos resultantes de entalamentos e de cortes.

Symbolbeskrivelse



Der må ikke benyttes eddikesyreholdig silikone!

Descrição do símbolo



Não utilizar silicone que contenha ácido acético!



Målene (se s. 17)



Medidas (ver página 17)



Brugsanvisning (se s. 18)



Funcionamento (ver página 18)



Service (se s. 19)

Ifølge DIN EN 1717 skal gennemstrømningsbegrænsere i overensstemmelse med nationale regler afprøves regelmæssigt (mindst en gang om året).
Med indbygget kontraventil



Manutenção (ver página 19)

As válvulas anti-retorno devem ser verificadas regularmente de acordo com a DIN EN 1717 segundo os regulamentos nacionais ou regionais (pelo menos uma vez por ano).
Função anti-retorno e anti-vácuo



Rengøring

For anbefalinger til rengøringen, se venligst den vedlagte brochure.



Limpeza

Consultar a seguinte brochura sobre as recomendações de limpeza.



Reservedele (se s. 20)

XXX = Overflade
000 = Krom
090 = Krom/guld optic
120 = Krom/porcelæn
820 = Brushed nickel
830 = Polished nickel



Peças de substituição (ver página 20)

XXX = Acabamentos
000 = cromado
090 = cromado/ouro ótica
120 = cromado/porcelana
820 = brushed nickel
830 = polished nickel



Godkendelse (se s. 21)



Marca de controlo
(ver página 21)

Montering
se s. 16



Montagem
ver página 16



Wskazówki bezpieczeństwa

 Aby uniknąć zranień, takich jak zgniecenia czy przecięcia, podczas montażu należy nosić rękawice.

Bezpečnostní pokyny

 Pro zabránění řezným zraněním a pohmožděním je nutné při montáži nosit rukavice.

Opis symbolu



Nie stosować silikonów zawierających kwas octowy!



Wymiary (patrz strona 17)



Obsługa (patrz strona 18)



Konserwacja (patrz strona 19)

Działanie zabezpieczeń przed przepływem zwrotnym, zgodnie z normą DIN EN 1717 i miejscowymi przepisami, musi być kontrolowane (DIN 1988, raz w roku).

Samoistnie zabezpieczony przed przepływem zwrotnym



Czyszczenie

Zalecenie dotyczące pielęgnacji, patrz dołączona broszura.



Części serwisowe (patrz strona 20)

XXX = kody wykończenia powierzchni

000 = chrom

090 = chrom/złoty szlachetna

120 = chrom/porcelana

820 = nikiel szorowany

830 = nikiel polerowany

Popis symbolů



Nepoužívat silikon s obsahem kyseliny octové!



Rozměry (viz strana 17)



Ovládání (viz strana 18)



Údržba (viz strana 19)

U zpětných ventilů se musí podle DIN EN 1717 v souladu s národními nebo regionálními předpisy testovat jejich funkčnost (alespoň jednou ročně).

Vlastní jištění proti zpětnému nasátí.



Čištění

Doporučení k čištění viz příložená brožura.



Servisní díly (viz strana 20)

XXX = kód povrchové úpravy

000 = chrom

090 = chrom/zlato ocel

120 = chrom/porcelán

820 = brushed nickel

830 = polished nickel



Znak jakości (patrz strona 21)



zkoušební značka (viz strana 21)

Montáž
patrz strona 16



Montáž
viz strana 16

**! Bezpečnostné pokyny**

! Pri montáži musíte nosiť rukavice, aby ste predišli pomliaždeninám a rezným poraneniam.

! 安全技巧

! 装配时为避免挤压和切割受伤，必须戴上手套。

Popis symbolov

Nepoužívať silikón s obsahom kyseliny octovej!



Rozmery (vid' strana 17)



Obsluha (vid' strana 18)



Údržba (vid' strana 19)

Pri spätných ventiloch sa musí podľa DIN EN 1717 v súlade s národnými alebo regionálnymi predpismi testovať ich funkčnosť (aspoň raz ročne).
Vlastná poistka proti spätnému nasatiu.



Čištění

Odporúčanie o čistení nájdete v priloženej brožúre.



Servisné diely (vid' strana 20)

XXX = kód povrchovej úpravy
000 = chróm
090 = chróm/zlato ocel
120 = chróm/porcelán
820 = brushed nickel
830 = polished nickel

符号说明

请勿使用含有乙酸的硅！



大小 (参见第 17 页)



操作 (参见第 18 页)



保养 (参见第 19 页)

单向阀必须在符合国家或当地的法律的情况下按照DIN EN 1717定期检查（至少一年一次）。
自动防止回流



清洗

清洁建议参见附入的小册子。



备用零件 (参见第 20 页)

XXX = 颜色代码
000 = 镀铬
090 = 镀铬/黑色
120 = 镀铬/瓷器色
820 = 镍拉丝
830 = 镍抛光



Osvedčenie o skúške
(vid' strana 21)



检验标记 (参见第页 21)

Montáž
vid' strana 16



安裝
参见第页 16



Указания по технике безопасности

 Во время монтажа следует надеть перчатки во избежание прищемления и порезов.

Biztonsági utasítások

 A szerelésnél a zúzódások és vágási sérülések elkerülése érdekében kesztyűt kell viselni.

Описание символов



Не применяйте силикон, содержащий уксусную кислоту.



Размеры (см. стр. 17)



Эксплуатация (см. стр. 18)



Техническое обслуживание (см. стр. 19)

Защита обратного тока должна регулярно проверяться (минимум один раз в год) по стандарту DIN EN 1717 или в соответствии с национальными или региональными нормативами

укомплектован клапаном обратного тока воды



Очистка

Рекомендации по очистке см. в прилагаемой брошюре.



Комплект (см. стр. 20)

XXX = Код цвета поверхности

000 = хром

090 = хром/глянцевое золото

120 = хром/фарфор

820 = brushed nickel

830 = polished nickel

Szimbólumok leírása



Ne használjon ecetsavtartalmú szilikont!



Méretet (lásd a 17. oldalon)



Használat (lásd a 18. oldalon)



Karbantartás (lásd a 19. oldalon)

A visszafolyásgátlók működése a DIN EN 1717 szabványnak megfelelően, a nemzeti vagy területi rendelkezésekkel összhangban, évente egyszer ellenőrizendő!
Visszafolyás gátlóval



Tisztítás

Az ajánlott tisztításhoz lásd a mellékelt brosúrát.



Tartozékok (lásd a 20. oldalon)

XXX = Színkódok

000 = króm

090 = króm/arany-hatású

120 = króm/porcelán

820 = brushed nickel

830 = polished nickel



Знак технического контроля (см. стр. 21)



Vizsgajel (lásd a oldalon 21)

Монтаж
см. стр. 16



Szerelés
lásd a oldalon 16

**! Turvallisuusohjeet**

! Asennuksessa on käytettävä käsineitä puristumien ja viiltojen aiheuttamien tapaturmien estämiseksi.

! Säkerhetsanvisningar

! Handskar ska bäras under monteringsarbetet så att man kan undvika kläm- och skärskadorgen werden.

Merkin kuvaus

Älä käytä etikahappopitoista silikonia!



Använd inte silikon som innehåller ättiksyra!



Mitat (katso sivu 17)



Måtten (se sidan 17)



Käyttö (katso sivu 18)



Hantering (se sidan 18)



Huolto (katso sivu 19)



Skötsel (se sidan 19)

Vastaventtiilien toiminta on tarkastettava säännöllisesti paikallisten ja kansallisten määräysten mukaisesti (DIN 1988, kerran vuodessa).

Estää itsestään paluuvirtauksen

Backventilens funktion måste kontrolleras regelbundet enligt nationella eller regionala bestämmelser (DIN 1988 en gång per år) i enlighet med DIN EN 1717.
Självspärr mot återflöde



Puhdistus

Katso puhdistussuositus mukana olevasta esitteestä.



Rengöring

Se den medföljande broschyren för rengöringsrekommendation



Varaosat (katso sivu 20)

XXX = Värikoodi
000 = kromi
090 = kromi/kultaoptiikka
120 = kromi/posliini
820 = harjattu nikkeli
830 = kiillotettu nikkeli



Reservdelar (se sidan 20)

XXX = Färgkodning
000 = krom
090 = krom/guld-optik
120 = krom/porslin
820 = borstad nickel
830 = polerad nickel



Koetusmerkki (katso sivu 21)



Testsigill (se sidan 21)

Asennus
katso sivu 16



Montering
se sidan 16



Saugumo technikos nurodymai

 Apsaugai nuo užspaudimo ir įsijovavimo montavimo metu mūvėkite pirštines.

Sigurnosne upute

 Prilikom montaže se radi sprječavanja prignječenja i posjekotina moraju nositi rukavice.

Simbolio aprašymas



Nenaudokite silikono, kurio sudėtyje yra acto rūgšties!



Išmatavimai (žr. psl. 17)



Eksplotacija (žr. psl. 18)



Techninis aptarnavimas (žr. psl. 19)

Atbuliniu vožtuvu apsauga privalo būti tikrinama reguliariai (mažiausiai kartą per metus pagal DIN 1988) pagal DIN EN1717 arba pagal galiojančias nacionalines arba regionines normas.

Su atbuliniu vožtuvu **Valymas**



Valymo rekomendacijas žr. pridedamoje brošiūroje.



Atsarginės dalys (žr. psl. 20)

XXX = Spalva
000 = chrom
090 = chrominė (aukso optika)
120 = chrom/porcelianas
820 = brushed nickel
830 = polished nickel

Opis simbola



Nemojte koristiti silikon koji sadrži octenu kiselinu!



Mjere (pogledaj stranicu 17)



Upotreba (pogledaj stranicu 18)



Održavanje (pogledaj stranicu 19)

Ispravnost nepovratnog ventila mora se redovito proveravati prema standardu DIN EN 1717 i u skladu sa važećim propisima (najmanje jednom godišnje).
Funkcije samo-čišćenja



Čišćenje

Upute za čišćenje nalaze se u priloženoj brošiuri.



Rezervni djelovi (pogledaj stranicu 20)

XXX = Boje
000 = krom
090 = optika krom/zlato
120 = krom/porculan
820 = brushed nickel
830 = polished nickel



Bandyimo pažyma (žr. psl. 21)



Oznaka testiranja (pogledaj stranicu 21)

Montavimas
žr. psl. 16



Sastavljanje
pogledaj stranicu
16



! Güvenlik uyarıları

! Montaj esnasında ezilme ve kesilme gibi yaralanmaları önlemek için eldiven kullanılmalıdır.

! Instrucțiuni de siguranță

! La montare utilizați mănuși pentru evitarea contuziunilor și tăierii mâinilor.

Simge açıklaması



Asetik asit içeren silikon kullanmayın!



Ölçüleri (Bakınız sayfa 17)



Kullanımı (Bakınız sayfa 18)



Bakım (Bakınız sayfa 19)

DIN EN 1717 ve ulusal standartlar doğrultusunda Çek valfler düzenli olarak kontrol edilmelidir. (en az yılda bir kez)
Geri emme önleyici



Temizleme

Temizlik önerisi için birlikte verilen broşüre bakınız.



Yedek Parçalar (Bakınız sayfa 20)

XXX = Renkler
000 = krom
090 = krom/altın-optik
120 = krom/porselen
820 = brushed nickel
830 = polished nickel

Descrierea simbolurilor



Nu utilizați silicon cu conținut de acid acetic!



Dimensiuni (vezi pag. 17)



Utilizare (vezi pag. 18)



Întreținere (vezi pag. 19)

Supapele de reținere trebuie verificate regulat conform DIN EN 1717 și standardele naționale sau regionale (anual conform DIN 1988).
Asigurat contra scurgere înapoi



Curățare

Pentru recomandările referitoare la curățare vezi broșura alăturată.



Piese de schimb (vezi pag. 20)

XXX = cod de culori
000 = crom
090 = crom/auriu optic
120 = crom/ porțelan
820 = nichel mat
830 = nichel lucios



Kontrol işareti (Bakınız sayfa 21)



Certificat de testare (vezi pag. 21)

Montajı
Bakınız sayfa 16



Montare
vezi pag. 16



Υποδειξεις ασφαλείας

 Για να αποφύγετε τραυματισμούς κατά τη συναρμο-
λόγηση πρέπει να φοράτε γάντια.

Περιγραφή συμβόλων



Μην χρησιμοποιείτε σιλικόνη που περιέχει
οξικό οξύ!



Διαστάσεις (βλ. σελίδα 17)



Χειρισμός (βλ. σελίδα 18)



Συντήρηση (βλ. σελίδα 19)

Οι βαλβίδες αντεπιστροφής πρέπει να ελέγ-
χονται τακτικά ως προς τη λειτουργία τους,
σύμφωνα με τις οδηγίες DIN EN 1717, σε
σχέση με τους ισχύοντες εθνικούς ή τοπικούς
κανόνες (το ελάχιστο μια φορά το χρόνο,
σύμφωνα με το πρότυπο DIN 1988)
Περιλαμβάνει βαλβίδα αντεπιστροφής.



Καθαρισμός

Για οδηγίες καθαρισμού βλέπε συνημμένο
ενημερωτικό φυλλάδιο.



Ανταλλακτικά (βλ. σελίδα 20)

XXX = Χρώματα
000 = Επιχρωμιωμένο
090 = Επιχρωμιωμένο/οπτική χρυσού
120 = Επιχρωμιωμένο/πορσελάνη
820 = νίκελ ματ
830 = νίκελ γυαλιστερό

Varnostna opozorila

 Pri montaži je treba nositi rokavice, da se preprečijo
poškodbe zaradi zmečkanja ali urezov.

Opis simbola



Ne smete uporabiti silikona, ki vsebuje
ocetno kislino!



Dimensions (glejte stran 17)



Upravljanje (glejte stran 18)



Vzdrževanje (glejte stran 19)

Delovanje protipovratnega ventila je
potrebno v skladu z DIN EN 1717 in
skladno z državnimi in regionalnimi določili
(DIN 1988 enkrat letno) redno testirati.
Zaščita proti povratnemu toku



Čiščenje

Prporočilo za čiščenje glejte v priloženi
brošuri.



Rezervni deli (glejte stran 20)

XXX = Barve
000 = krom
090 = krom/pozlačena
120 = krom/porcelan
820 = brushed nickel
830 = polished nickel



Σήμα ελέγχου (βλ. Σελίδα 21)



Preskusni znak (glejte stran 21)

Συναρμολόγηση
βλ. Σελίδα 16



Montaža
glejte stran 16

**! Ohutusjuhised**

⚠ Kandke paigaldamisel muljumis- ja löikevigastuste vältimiseks kindaid.

! Drošības norādes

⚠ Montāžas laikā, lai izvairītos no saspiedumiem un iegriezumiem, nepieciešams nēsāt cimdus.

Sūmbolite kirjeldus

Ärge kasutage äädikhapet sisaldavat silikooni!



Mõõtude (vt lk 17)



Kasutamine (vt lk 18)



Hooldus (vt lk 19)

Tagasilöögiklappide toimimist tuleb kooskõlas riiklike ja regionaalsete määrustega regulaarselt kontrollida vastavalt standardile DIN EN 1717 (DIN 1988 - kord aastas).
tagasivooluklapp



Puhastamine

Puhastussoovitusi vt kaasasolevast brošüürist.



Varuosad (vt lk 20)

XXX = Värvikood
000 = kroom
090 = kroom/kuld optik
120 = kroom/portselan
820 = brushed nickel
830 = polished nickel

Symbolu nozīme

Neizmantojiet silikonu, kas satur etiķskābi!



Izmērus (skat. 17. lpp.)



Lietošana (skat. 18. lpp.)



Apkope (skat. 19. lpp.)

Regulāri jāpārbauda pretvārsta funkcija saskaņā ar DIN EN 1717 saistībā ar nacionālajiem vai vietējiem noteikumiem (DIN 1988 vienreiz gadā).
Drošības vārsts



Tīrīšana

Ieteikumus tīrīšanai skatiet pievienotajā brošūrā.



Rezerves daļas (skat. 20. lpp.)

XXX = Krāsas
000 = hroma
090 = hroma/zelta
120 = hroma/porcelāna
820 = brushed nickel
830 = polished nickel



Kontrollsertifikaat (vt lk 21)



Pārbaudes zīme (skat. lpp. 21)

Paigaldamine
vt lk 16



Montāža
skat. lpp. 16



Sigurnosne napomene

 Prilikom montaže se radi sprečavanja prignječenja i posekotina moraju nositi rukavice.

Sikkerheshenvisninger

 Bruk hansker under montasjen for å unngå klem- og kuttskader.

Opis simbola



Nemojte koristiti silikon koji sadrži sircetnu kiselinu!



Mere (vidi stranu 17)



Rukovanje (vidi stranu 18)



Održavanje (vidi stranu 19)

Isppravno funkcionisanje nepovratnog ventila se mora redovno proveravati prema standardu DIN EN 1717 i u skladu s važećim nacionalnim ili regionalnim propisima (DIN 1988 jednom godišnje). Zaštita od povratnog toka



Čišćenje

Preporuke za čišćenje možete naći u priloženoj brošuri.



Rezervni delovi (vidi stranu 20)

XXX = Oznake boja
000 = hrom
090 = dezen hrom/zlatna
120 = hrom/porcelan
820 = brushed nickel
830 = polished nickel

Symbolbeskrivelse



Ikke bruk silikon som inneholder eddiksyre!



Mål (se side 17)



Betjening (se side 18)



Vedlikehold (se side 19)

Funksjonen til returløpssperren skal iht. DIN EN 1717 og i samsvar med de nasjonale og lokale forskrifter sjekkes regelmessig (DIN 1988 en gang i året). Egensikker mot tilbakeflyt



Rengjøring

Se vedlagt brosjyre for rengjøringsanbefalinger.



Serviceleder (se side 20)

XXX = Oznake boja
000 = hrom
090 = dezen hrom/zlatna
120 = hrom/porcelan
820 = brushed nickel
830 = polished nickel



Ispitni znak (vidi stranu 21)



Prøvemerket (se side 21)

Montaža
vidi stranu 16



Montasje
se side 16



Указания за безопасност

 При монтажа трябва да се носят ръкавици, за да се избегнат наранявания поради притискане или порязване.

Описание на символите



Не използвайте силикон, съдържащ оцетна киселина!



Размери (вижте стр. 17)



Обслужване (вижте стр. 18)



Поддръжка (вижте стр. 19)

Съгласно DIN EN 1717 редовно трябва да се проверява функционирането на приспособленията за предотвратяване на обратния поток в съответствие с националните или регионални изисквания (DIN 1988 веднъж годишно).

Самозащитен против обратно изтичане



Почистване

Вижте препоръките при почистване от приложената брошура.



Сервизни части (вижте стр. 20)

XXX = Oznake boja

000 = hrom

090 = dezen hrom/zlatna

120 = hrom/porcelan

820 = brushed nickel

830 = polished nickel

Udhëzime sigurie

 Për të evituar lëndimet e pickimeve ose të prerjeve gjatë procesit të montimit duhet që të vishni doreza.

Përshkrimi i simbolit



Mos përdorni silikon që në përbërje ka acid acetik.



Përmasat (shih faqen 17)



Përdorimi (shih faqen 18)



Mirëmbajtja (shih faqen 19)

Penguesit e rrjedhjes në drejtim të kundërt duhen kontrolluar rregullisht në bazë të normave DIN EN 1717 konform normave nacionale dhe regionale (DIN 1988 një herë në vit).

Siguresa kundër rrjedhjes në drejtim të kundërt

Pastrimi



Për rekomandime mbi pastrimin shikoni broshurën bashkëngjitur.



Pjesë ndërrimi (shih faqen 20)

XXX = Oznake boja

000 = hrom

090 = dezen hrom/zlatna

120 = hrom/porcelan

820 = brushed nickel

830 = polished nickel



Контролен знак (вижте стр. 21)



Shenja e kontrollit (shih faqen 21)

Монтаж
вижте стр. 16



Montimi
shih faqen 16



تنبيهات الأمان

يجب ارتداء قفازات اليد أثناء التركيب لتجنب حدوث أضرار الإنحسار أو الجروح.



وصف الرمز

هام! لا تستخدم السليكون الذي يحتوي على أحماض!



أبعاد (راجع صفحة 17)



التشغيل (راجع صفحة 18)



الصيانة (راجع صفحة 19)



يجب فحص صمام عدم الرجوع بصفة منتظمة حسب المواصفة DIN EN 1717 وذلك طبقاً للوائح الوطنية أو الإقليمية (مرة واحد سنوياً طبقاً للمواصفة DIN 1988).
خاصية عدم التدفق العكسي

التنظيف



للاطلاع على النصائح الخاصة بالتنظيف انظر الكتيب المرفق.

قطع الغيار (راجع صفحة 20)



XXX = الألوان
000 = كروم
090 = كروم/لون ذهبي
120 = كروم/بورسيلين
820 = نيكل مُقرّش
830 = نيكل مصقول

شهادة اختبار (راجع صفحة 21)



الترايب

راجع صفحة 16



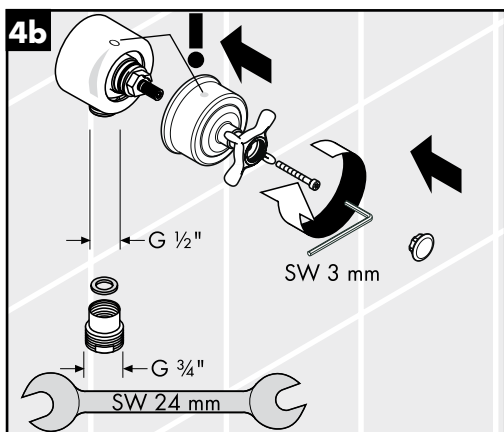
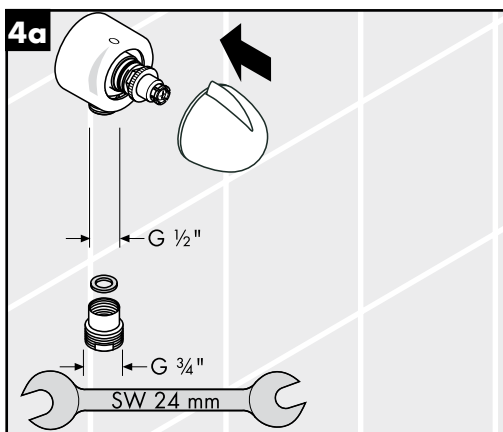
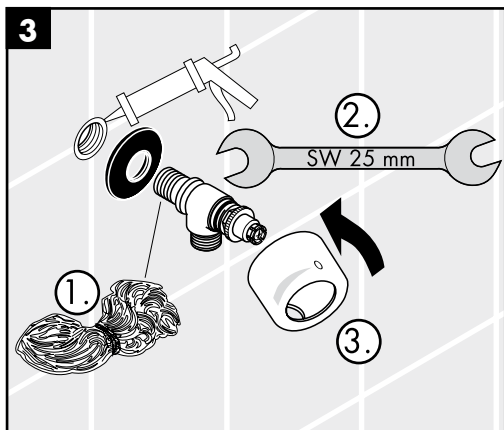
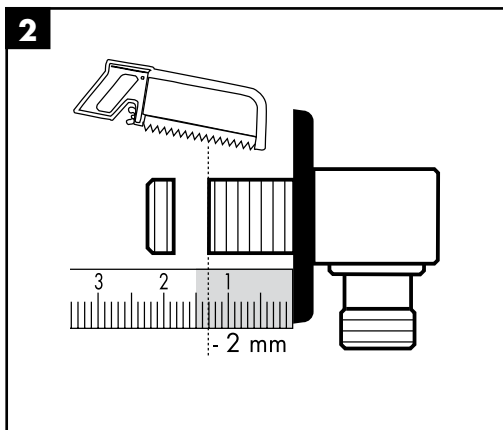
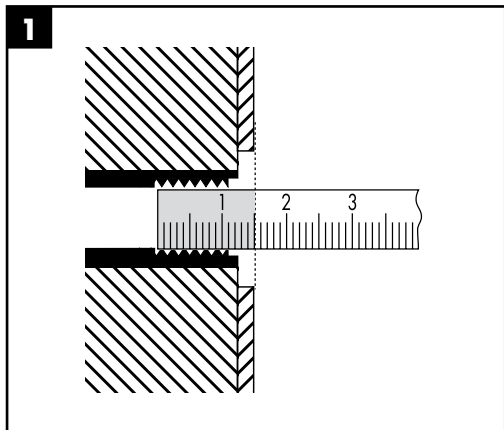
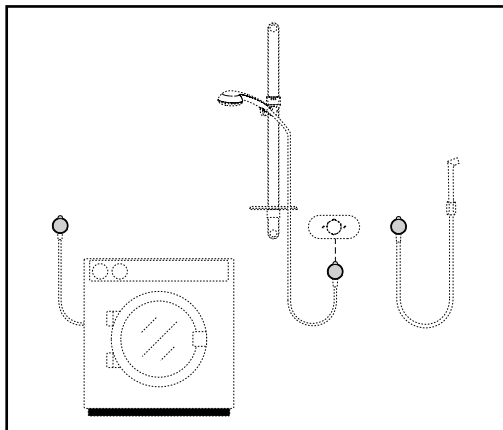



Starck
10882XXX

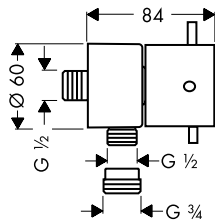

Montreux
16882XXX

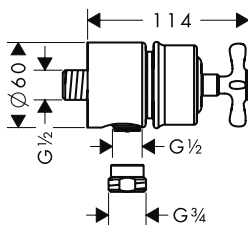

Carlton
17882XXX

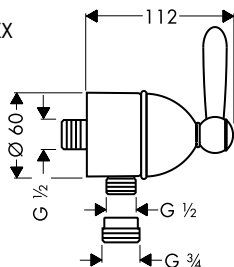

Carlton
17883XXX

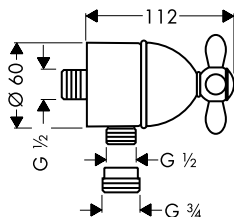

Steel
35882800

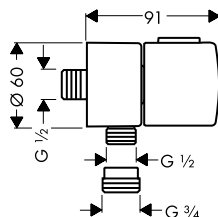

Terrano
37882XXX

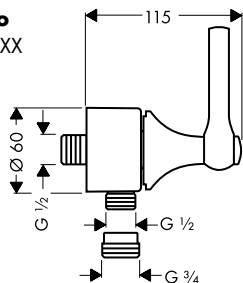

Terrano
37883XXX

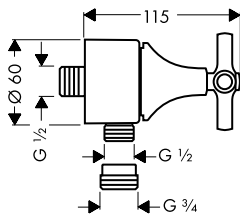

Uno
38882XXX

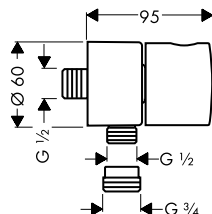

Citterio
39882XXX

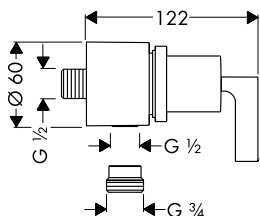

Citterio
39883XXX

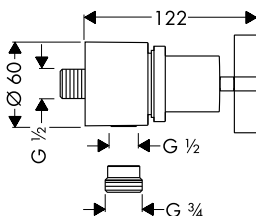

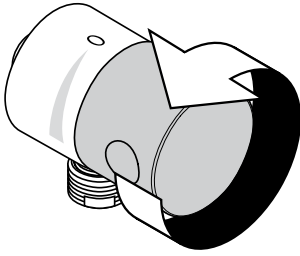

öffnen / ouvert / open / aperto / abierto / open / åbne /
abrir / otworzyć / otevřít / otvorit / 开 / открыть / nyítás /
avaaminen / öppna / atidaryti / Отваранье / açmak /
deschide / ανοικτό / odpreti / avage / atvērt /
otvoriti / åpne / отварање / hare / فتح

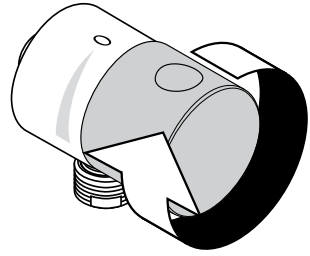

schließen / fermé / close / chiudere / cerrar / sluiten /
lukke / fechar / zamknąć / zavřít / uzavriev / 关 /
закрыть / bezárás / sulkeminen / stänga / uždaryti /
Zatvaranje / kapatmak / închide / κλειστό /
zarpeti / sulgege / aizvērt / zatvori / lukke / затварање /
mbylle / إغلاق

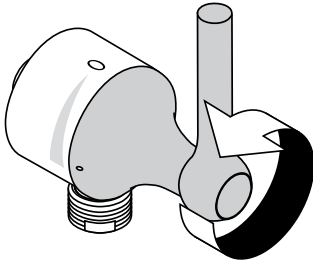

öffnen / ouvert / open / aperto / abierto / open / åbne /
abrir / otworzyć / otevřít / otvorit / 开 / открыть / nyítás /
avaaminen / öppna / atidaryti / Отваранье / açmak /
deschide / ανοικτό / odpreti / avage / atvērt /
otvoriti / åpne / отварање / hare / فتح

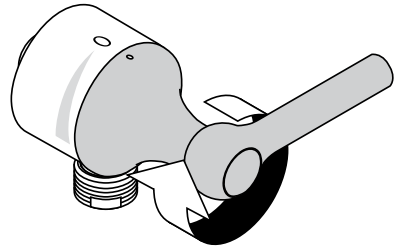

schließen / fermé / close / chiudere / cerrar / sluiten /
lukke / fechar / zamknąć / zavřít / uzavriev / 关 /
закрыть / bezárás / sulkeminen / stänga / uždaryti /
Zatvaranje / kapatmak / închide / κλειστό /
zarpeti / sulgege / aizvērt / zatvori / lukke / затварање /
mbylle / إغلاق

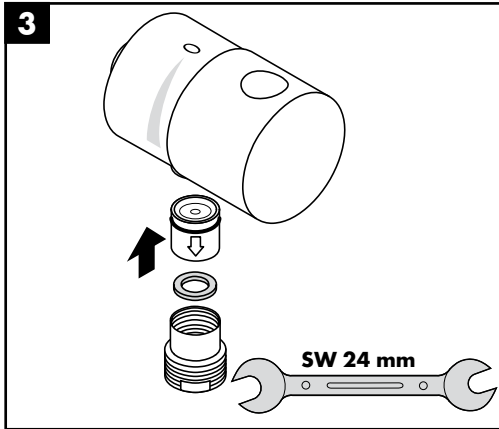
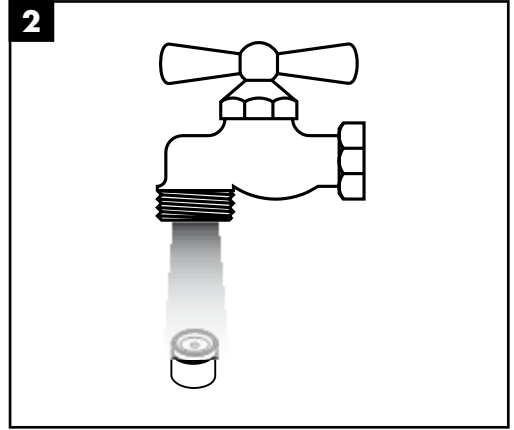
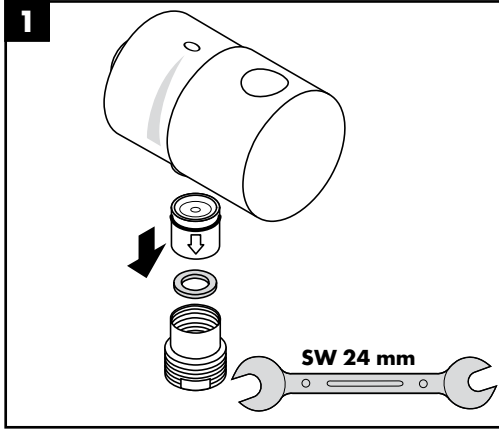



Starck 10882XXX / **Steel** 35882800 / **Terrano** 37882XXX / **Terrano** 37883XXX / **Uno** 38882XXX /
Citterio 39882XXX / **Citterio** 39883XXX

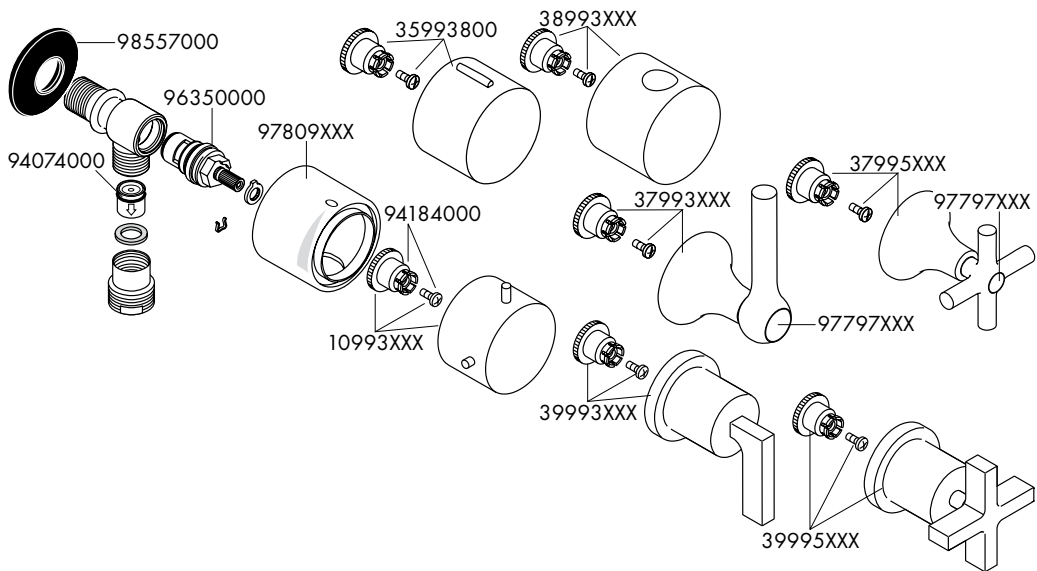

Montreux 16882XXX

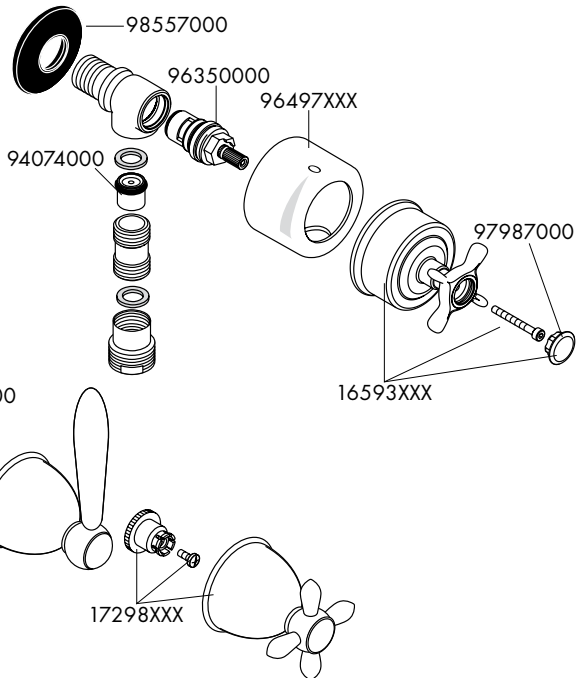

Carlton 17882XXX / **Carlton** 17883XXX

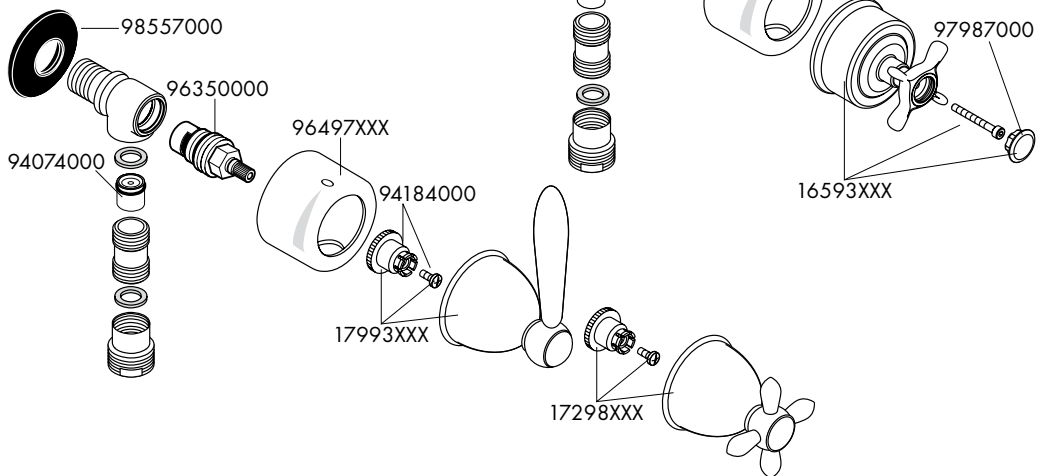



	P-IX	DVGW	SVGW	WRAS	KIWA	NF	ACS	ETA
10882XXX				X			X	
16882XXX							X	
17882XXX				X			X	
17883XXX				X			X	
35882800				X			X	
37882XXX				X			X	
37883XXX				X			X	
38882XXX				X			X	
39882XXX				X			X	
39883XXX				X			X	

hansgrohe

Hansgrohe - Postfach 1145 · D-77761 Schiltach · Telefon +49 (0) 78 36/51-1282 · Telefax +49 (0) 7836/511440
E-Mail: info@hansgrohe.com · Internet: www.hansgrohe.com

03/2010
9.08627.07