

<b>DE</b>	Gebrauchsanleitung / Montageanleitung	2
<b>FR</b>	Mode d'emploi / Instructions de montage	2
<b>EN</b>	Instructions for use / assembly instructions	2
<b>IT</b>	Istruzioni per l'uso / Istruzioni per Installazione	2
<b>ES</b>	Modo de empleo / Instrucciones de montaje	3
<b>NL</b>	Gebruiksaanwijzing / Handleiding	3
<b>DK</b>	Brugsanvisning / Monteringsvejledning	3
<b>PT</b>	Instruções para uso / Manual de Instalação	3
<b>PL</b>	Instrukcja obsługi / Instrukcja montażu	4
<b>CS</b>	Návod k použití / Montážní návod	4
<b>SK</b>	Návod na použitie / Montážny návod	4
<b>ZH</b>	用户手册 / 组装说明	4
<b>RU</b>	Руководство пользователя / Инструкция по монтажу	5
<b>HU</b>	Használati útmutató / Szerelési útmutató	5
<b>FI</b>	Käyttöohje / Asennusohje	5
<b>SV</b>	Bruksanvisning / Monteringsanvisning	5
<b>LT</b>	Vartotojo instrukcija / Montavimo instrukcijos	6
<b>HR</b>	Upute za uporabu / Uputstva za instalaciju	6
<b>TR</b>	Kullanım kılavuzu / Montaj kılavuzu	6
<b>RO</b>	Manual de utilizare / Instrucțiuni de montare	6
<b>EL</b>	Οδηγίες χρήσης / Οδηγία συναρμολόγησης	7
<b>SL</b>	Navodilo za uporabo / Navodila za montažo	7
<b>ET</b>	Kasutusjuhend / Paigaldusjuhend	7
<b>LV</b>	Lietošanas pamācība / Montāžas instrukcija	7
<b>SR</b>	Uputstvo za upotrebu / Uputstvo za montažu	8
<b>NO</b>	Bruksanvisning / Montasjeveiledning	8
<b>BG</b>	Инструкция за употреба / Инструкция за употреба	8
<b>SQ</b>	Udhëzuesi i përdorimit / Udhëzime rreth montimit	8
<b>AR</b>	دليل الاستخدام / تعليمات التجميع	9

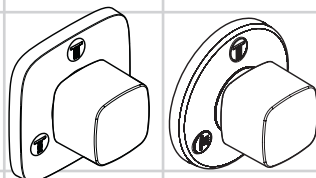

**Trio / Quattro Classic**  
15934XXX



**Trio / Quattro PuraVida**  
15937XXX

**Trio / Quattro Metris**  
31634000

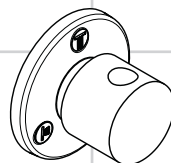

**Trio / Quattro S**  
15932000

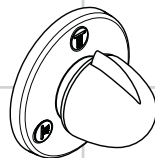

**Trio / Quattro E**  
15931000



## Sicherheitshinweise

-  Bei der Montage müssen zur Vermeidung von Quetsch- und Schnittverletzungen Handschuhe getragen werden.

## Montagehinweise

Die Armatur muss nach den gültigen Normen montiert, gespült und geprüft werden!



Kein essigsäurehaltiges Silikon verwenden!



**Serviceteile** (siehe Seite 12)



**Maße** (siehe Seite 14)



**Prüfzeichen** (siehe Seite 15)

**Montage  
siehe Seite 10**



## Consignes de sécurité

-  Lors du montage, porter des gants de protection pour éviter toute blessure par écrasement ou coupure.

## Instructions pour le montage

La robinetterie doit être installée, rincée et contrôlée conformément aux normes valables!



Ne pas utiliser de silicone contenant de l'acide acétique!



**Pièces détachées** (voir pages 12)



**Dimensions** (voir page 14)



**Classification acoustique et débit** (voir page 15)

**Montage  
voir page 10**



## Safety Notes

-  Gloves should be worn during installation to prevent crushing and cutting injuries.

## Installation Instructions

The fitting must be installed, flushed and tested after the valid norms!



Do not use silicone containing acetic acid!



**Spare parts** (see page 12)



**Dimensions** (see page 14)



**Test certificate** (see page 15)

**Assembly  
see page 10**



## Indicazioni sulla sicurezza

-  Durante il montaggio, per evitare ferite da schiacciamento e da taglio bisogna indossare guanti protettivi.

## Istruzioni per il montaggio

La rubinetteria deve essere installata, pulita e testata secondo le istruzioni riportate!



Non utilizzare silicone contenente acido acetico!



**Parti di ricambio** (vedi pagg. 12)



**Ingombri** (vedi pagg. 14)



**Segno di verifica** (vedi pagg. 15)

**Montaggio  
vedi pagg. 10**

**! Indicaciones de seguridad**

⚠ Durante el montaje deben utilizarse guantes para evitar heridas por aplastamiento o corte.

**Indicaciones para el montaje**

El grifo tiene que ser instalado, probado y testado, según las normas en vigor.



No utilizar silicona que contiene ácido acético!



**Repuestos** (ver página 12)



**Dimensiones** (ver página 14)



**Marca de verificación** (ver página 15)

**Montaje**  
**ver página 10**

**! Veiligheidsinstructies**

⚠ Bij de montage moeten ter voorkoming van kneel- en snijwonden handschoenen worden gedragen.

**Montage-instructies**

Leidingen doorspoelen volgens Norm. De mengkraan vervolgens monteren en controleren!



Gebruik geen zuurhoudende silicone!



**Service onderdelen** (zie blz. 12)



**Maten** (zie blz. 14)



**Keurmerk** (zie blz. 15)

**Montage**  
**zie blz. 10**

**! Sikkerhedsanvisninger**

⚠ Ved monteringen skal der bruges handsker for at undgå kvæstelser og snitsår.

**Monteringsanvisninger**

Ifølge gældende regler, skal armaturet monteres, skylles igennem og afprøves.



Der må ikke benyttes eddikesyreholdig silikone!



**Reservedele** (se s. 12)



**Målene** (se s. 14)



**Godkendelse** (se s. 15)

**Montering**  
**se s. 10**

**! Avisos de segurança**

⚠ Durante a montagem devem ser utilizadas luvas de protecção, de modo a evitar ferimentos resultantes de entalamentos e de cortes.

**Avisos de montagem**

A misturadora deve ser instalada, purgada e testada de acordo com as normas em vigor!



Não utilizar silicone que contenha ácido acético!



**Peças de substituição**  
(ver página 12)



**Medidas** (ver página 14)



**Marca de controlo**  
(ver página 15)

**Montagem**  
**ver página 10**



## Wskazówki bezpieczeństwa

 Aby uniknąć zranień, takich jak zgniecenia czy przecięcia, podczas montażu należy nosić rękawice.

## Wskazówki montażowe

Armatura musi być zamontowana, przepłukana i wypróbowana według obowiązujących norm!



Nie stosować silikonów zawierających kwas octowy!



**Części serwisowe** (patrz strona 12)



**Wymiary** (patrz strona 14)



**Znak jakości** (patrz strona 15)

**Montaż**  
**patrz strona 10**

## Bezpečnostní pokyny

 Pro zabránění řezným zraněním a pohmožděním je nutné při montáži nosit rukavice.

## Pokyny k montáži

Armatura se musí montovat, proplachovat a testovat podle platných norem!



Nepoužívat silikon s obsahem kyseliny octové!



**Servisní díly** (viz strana 12)



**Rozměry** (viz strana 14)



**Zkušební značka** (viz strana 15)

**Montáž**  
**viz strana 10**



## Bezpečnostné pokyny

 Pri montáži musíte nosiť rukavice, aby ste predišli pomliaždeninám a rezným poraneniam.

## Pokyny pre montáž

Batéria sa musí montovať, preplachovať a testovať podľa platných noriem!



Nepoužívať silikón s obsahom kyseliny octovej!



**Servisné diely** (viď strana 12)



**Rozmery** (viď strana 14)



**Osvedčenie o skúške** (viď strana 15)

**Montáž**  
**viď strana 10**

## 安全技巧

 装配时为避免挤压和切割受伤，必须戴上手套。

## 安装提示

必须按照现行的规定安装，冲洗和测试产品！



请勿使用含有乙酸的硅！



备用零件 (参见第 12 页)



大小 (参见第 14 页)



检验标记 (参见第 15 页)

**安装**  
**参见第 10 页**





## Ук з ния по технике безоп сности

 Во время монтажа следует надеть перчатки во избежание прищемления и порезов.

## Ук з ния по монт жу

Смеситель должен быть смонтирован по действующим нормам и в соответствии с настоящей инструкцией, проверен на герметичность и безупречность работы



Не применяйте силикон, содержащий уксусную кислоту.



**Комплект** (см. стр. 12)



**Р змеры** (см. стр. 14)



**Зн к технического контроля**  
(см. стр. 15)

**Монт ж**  
**см. стр. 10**



## Biztonsági utasítások

 A szerelésnél a zúzódások és vágási sérülések elkerülése érdekében kesztyűt kell viselni.

## Szerelési utasítások

A csapelepet az érvényben lévő előírásoknak megfelelően kell felszerelni, átöblíteni és ellenőrizni!



Ne használjon ecetsavtartalmú szilikon!



**Tartozékok** (lásd a 12. oldalon)



**Méretet** (lásd a 14. oldalon)



**Vizsgajel** (lásd a 15. oldalon)

**Szerelés**  
**lásd a 10. oldalon**



## Turvallisuusohjeet

 Asennuksessa on käytettävä käsineitä puristumien ja viiltojen aiheuttamien tapaturmien estämiseksi.

## Asennusohjeet

Kaluste on asennettava, huuhdeltava ja tarkastettava voimassa olevien määräysten mukaisesti!



Älä käytä etikkahappopitoista silikonit!



**Varaosat** (katso sivu 12)



**Mitat** (katso sivu 14)



**Koetusmerkki** (katso sivu 15)

**Asennus**  
**katso sivu 10**



## Säkerhetsanvisningar

 Handskar ska bäras under monteringsarbetet så att man kan undvika kläm- och skärskadorgen werden.

## Monteringsanvisningar

Blandaren måste installeras, genomspolas och testas enligt gällande föreskrifter.



Använd inte silikon som innehåller ättiksyra!



**Reservdelar** (se sidan 12)



**Måtten** (se sidan 14)



**Testsigill** (se sidan 15)

**Montering**  
**se sidan 10**



## Saugumo technikos nurodymai

 Apsaugai nuo užspaudimo ir įsijovimo montavimo metu mūvėkite pirštines.

## Montavimo instrukcija

Maišytuvus privalo būti montuojamas, išleidžiamas ir patikrinamas pagal galiojančias normas!



Nenaudokite silikono, kurio sudėtyje yra acto rūgšties!



**Atsarginės dalys** (žr. psl. 12)



**Išmatavimai** (žr. psl. 14)



**Bandymo pažyma** (žr. psl. 15)

**Montavimas**  
žr. psl. 10



## Sigurnosne upute

 Prilikom montaže se radi sprječavanja prignječenja i posjekotina moraju nositi rukavice.

## Upute za montažu

Cijevi moraju biti postavljene, isprane i testirane prema važećim normama!



Nemojte koristiti silikon koji sadrži octenu kiselinu!



**Rezervni djelovi** (pogledaj stranicu 12)



**Mjere** (pogledaj stranicu 14)



**Oznaka testiranja** (pogledaj stranicu 15)

**Sastavljanje**  
pogledaj stranicu 10



## Güvenlik uyarıları

 Montaj esnasında ezilme ve kesilme gibi yaralanmaları önlemek için eldiven kullanılmalıdır.

## Montaj açıklamaları

Batarya geçerli normlara göre monte edilmeli, yıkanmalı ve kontrol edilmelidir!



Asetik asit içeren silikon kullanmayın!



**Yedek Parçalar** (Bakınız sayfa 12)



**Ölçüleri** (Bakınız sayfa 14)



**Kontrol işareti** (Bakınız sayfa 15)

**Montajı**  
Bakınız sayfa 10



## Instrucțiuni de siguranță

 La montare utilizați mănuși pentru evitarea contuziunilor și tăierii mâinilor.

## Instrucțiuni de montare

Bateria trebuie montată, clătită și verificată conform normelor în vigoare.



Nu utilizați silicon cu conținut de acid acetic!



**Piese de schimb** (vezi pag. 12)



**Dimensiuni** (vezi pag. 14)



**Certificat de testare** (vezi pag. 15)

**Montare**  
vezi pag. 10

**⚠ Υπ δείξεις σφ λεί ς**

⚠ Για να αποφύγετε τραυματισμούς κατά τη συναρμολόγηση πρέπει να φοράτε γάντια.

**Οδηγίες σ ν ρμ λόγησης**

Η κεντρική βάνα πρέπει να τοποθετηθεί, να πλυθεί και να ελεγχθεί με βάση τους ισχύοντες κανόνες υδραυλικής τέχνης!



Μην χρησιμοποιείτε σιλικόνη που περιέχει οξικό οξύ!



**Αντ λλ κτικά** (βλ. σελίδα 12)



**Δι στάσεις** (βλ. σελίδα 14)



**Σήμ ελέγχ** (βλ. σελίδα 15)

**Σ ν ρμ λόγηση  
βλ. σελίδ 10**

**⚠ Varnostna opozorila**

⚠ Pri montaži je treba nositi rokavice, da se preprečijo poškodbe zaradi zmečkanja ali urezov.

**Navodila za montažo**

Armaturo je potrebno montirati, sprati in testirati v skladu z veljavnimi normami!



Ne pas utiliser de silicone contenant de l'acide acétique!



**Rezervni deli** (glejte stran 12)

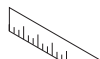

**Mere** (glejte stran 14)



**Preskusni znak** (glejte stran 15)

**Montaža  
Glejte stran 10.**

**⚠ Ohutusjuhised**

⚠ Kandke paigaldamisel muljumis- ja löikevigastuste vältimiseks kindaid.

**Paigaldamisjuhised**

Segisti paigaldamine, loputamine ja kontroll peab toimuma vastavalt kehtivatele normidele!



Ärge kasutage äädikhapet sisaldavat silikooni!



**Varuosad** (vt lk 12)



**Mõõtude** (vt lk 14)



**Kontrollsertifikaat** (vt lk 15)

**Paigaldamine  
vt lk 10**

**⚠ Drošības norādes**

⚠ Montāžas laikā, lai izvairītos no saspiedumiem un iegriezumiem, nepieciešams nēsāt cimdus.

**Norādījumi montāžai**

Armatūra jāuzstāda, jāizskalo un jāpārbauda atbilstoši spēkā esošajām normām!



Neizmantot silikonu, kas satur etiķskābi!



**Rezerves daļas** (skat. 12. lpp.)

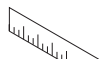

**Izmērus** (skat. 14. lpp.)



**Pārbaudes zīme** (skat. 15. lpp.)

**Montāža  
skat. 10. lpp.**



## Sigurnosne napomene

 Prilikom montaže se radi sprečavanja prignječenja i posekofina moraju nositi rukavice.

## Instrukcije za montažu

Armatura mora biti postavljena, isprana i testirana prema važećim normama!



Nemojte koristiti silikon koji sadrži sirćetnu kiselinu!



**Rezervni delovi** (vidi stranu 12)



**Mere** (vidi stranu 14)



**Ispitni znak** (vidi stranu 15)

**Montaža  
vidi stranu 10**



## Sikkerhetshenvisninger

 Bruk hansker under montasjen for å unngå klem- og kuttskader.

## Montagehenvisninger

Armaturen skal monteres iht. gyldige standarder. De skal spyles og sjekkes!



Ikke bruk silikon som inneholder eddiksyre!



**Service deler** (se side 12)



**Mål** (se side 14)



**Prøvermerke** (se side 15)

**Montasje  
se side 10**



## Ук з ния з безоп сност

 При монтажа трябва да се носят ръкавици, за да се избегнат наранявания поради притискане или порязване.

## Ук з ния з монт ж

Арматурата трябва да се монтира, промие и провери в съответствие с валидните норми!



Не използвайте силикон, съдържащ оцетна киселина!



**Сервизни ч сти** (вижте стр. 12)



**Р змери** (вижте стр. 14)



**Контролен зн к** (вижте стр. 15)

**Монт ж  
вижте стр. 10**



## Udhëzime sigurie

 Për të evituar lëndimet e pickimeve ose të prerjeve gjatë procesit të montimit duhet që të vishni doreza.

## Udhëzime për montimin

Armatura duhet montuar, shpërlarë dhe kontrolluar në bazë të normave të vlefshme!



Mos përdorni silikon që në përbërje ka acid acetik.



**Pjesë ndërrimi** (shih faqen 12)



**Përmasat** (shih faqen 14)



**Shenja e kontrollit**  
(shih faqen 15)

**Montimi  
shih faqen 10**





## تنبيهات الأمان



يجب إرتداء قفازات لليد أثناء التركيب لتجنب حدوث أخطار الإنحشار أو الجروح.

## عليمات التركيب

جب تركيب الوصلة، وغمرها بالماء واختبارها وفقاً للمعايير السارية!

هام! لا تستخدم السليكون الذي يحتوي على أحماض!



قطع الغيار (راجع صفحة 12)

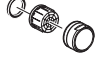

أبعاد (راجع صفحة 14)

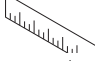

شهادة اختبار (راجع صفحة 15)



## الترايب

راجع صفحة 10



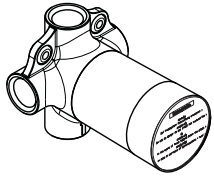

**Quattro**  
**15930180**

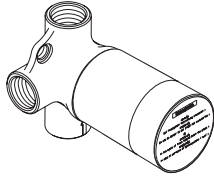

**Trio**  
**15981180**

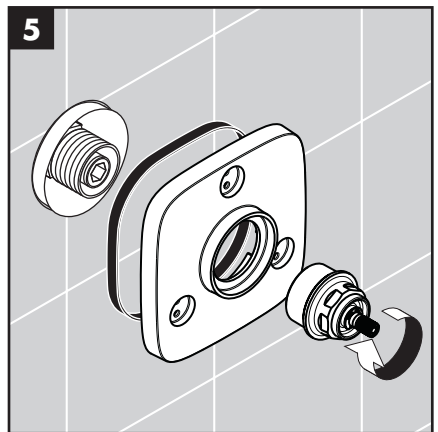
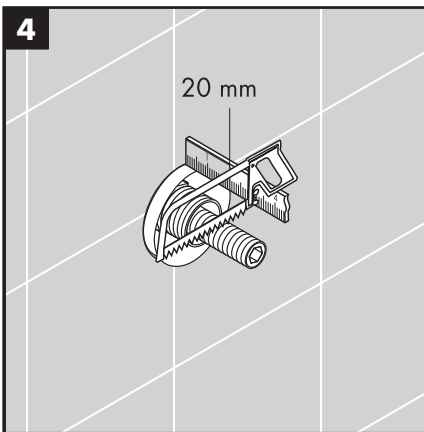
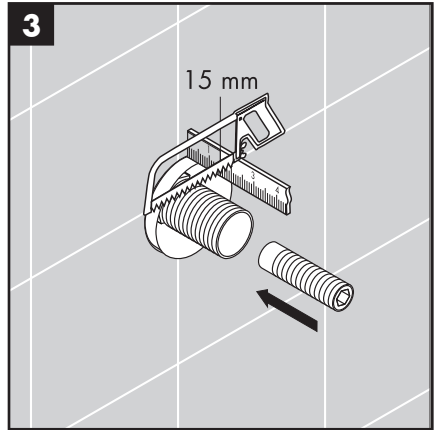
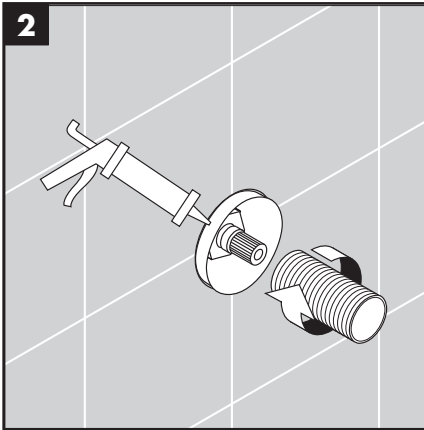
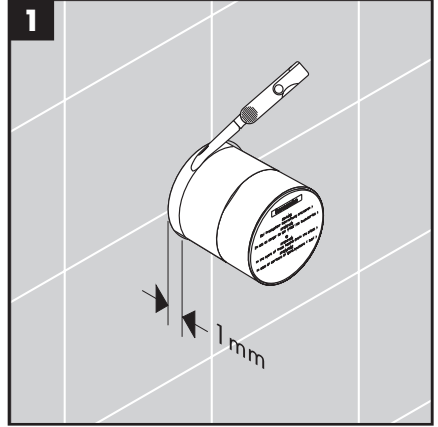

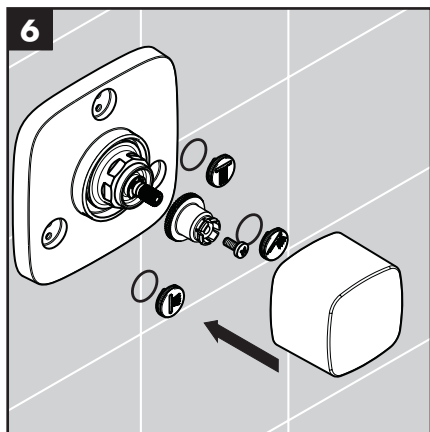



**Trio / Quattro E** 15931000  
**Trio / Quattro S** 15932000  
**Trio / Quattro Metris** 31634000

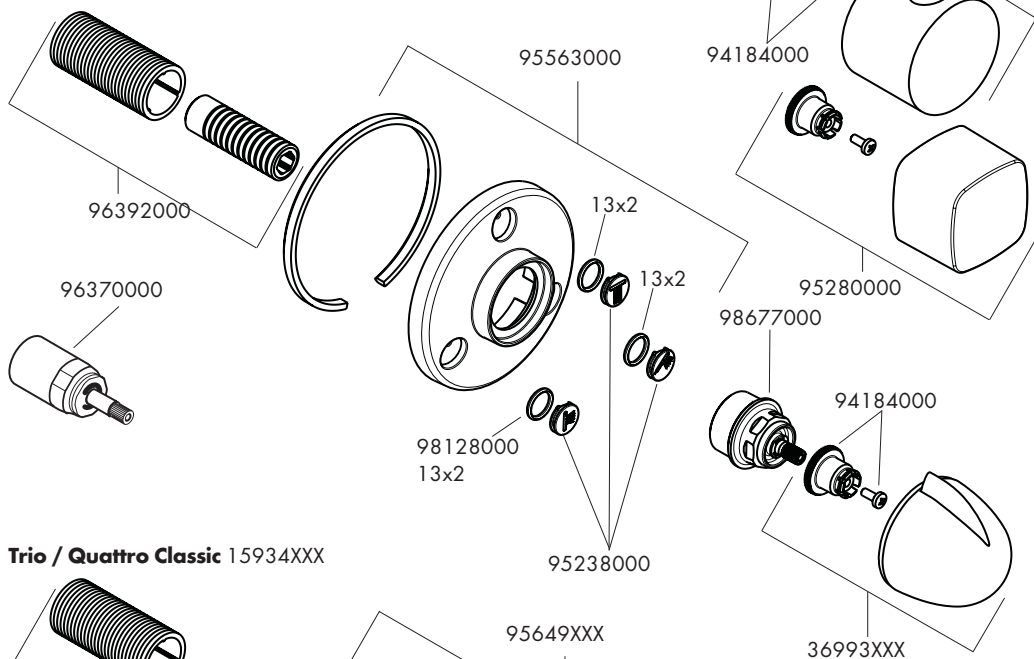

**Trio / Quattro Classic** 15934XXX

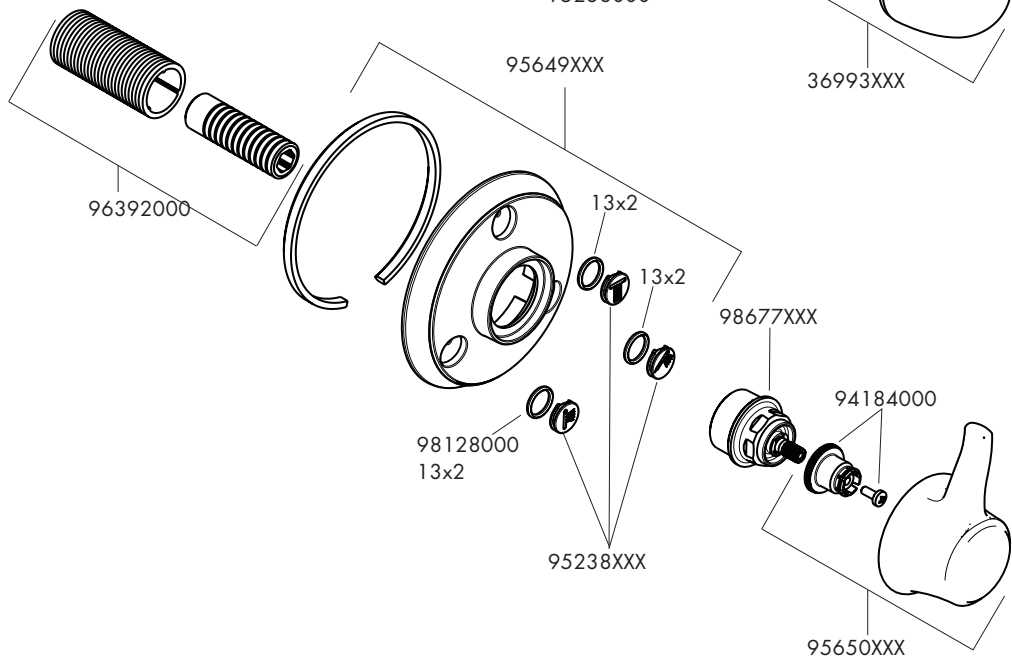



### Trio / Quattro PuraVida 15937XXX

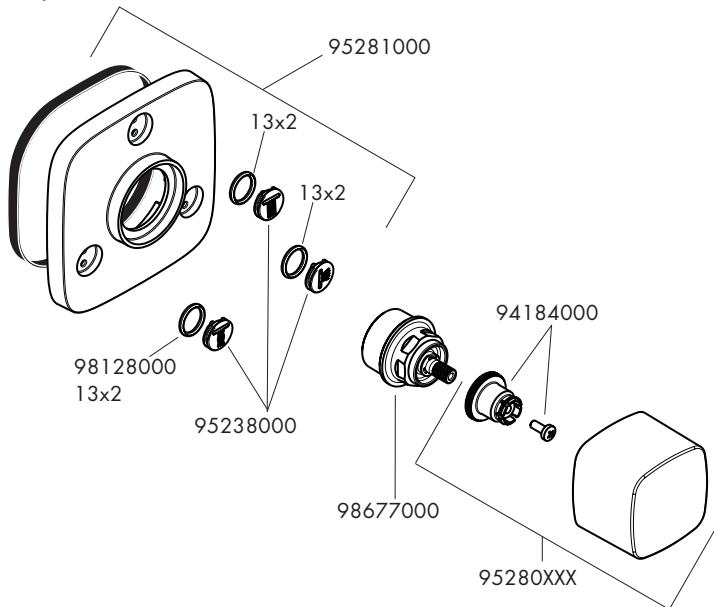

**XXX** = Farbcodierung // Couleurs // Colors // Trattamento // Acabados // Kleuren // Overflade // Acabamentos // Kody kolorów // Kód povrchové úpravy // Farebné označenie // 颜色代码 // Цветная кодировка // Színkódolás // Värikoodaus // Färgkodning // Spalvos // Boje // Renkler // Coduri de culori // Χρώματα // الألوان // Barve // Värvid // Krásu kodi // Oznake boja // Fargekode // Цветово кодирание // Kodimi me anë të ngjyrave

**000** = chrom // chromé // chrome plated // cromato // cromado // verchromd // Krom // cromado // chróm // 镀铬 // хром // króm // kromi // krom // crom // πιχρωμιμένο // أروم // kroom // hroma // hrom // хром

**400** = weiß/chrom // blanc/chromé // white/chrome plated // bianco/cromato // blanco/cromado // wit/verchromd // Hvid/Krom // branco/cromado // biaty/chrom // bílá/chrom // biela/chróm // 白色/镀铬 // белый/хром // fehér/króm // valkoinen/kromi // vit/krom // balta/chrom // bijela/krom // beyaz/Krom // alb/crom // λευκό/ πιχρωμιμένο // أبيض/أروم // bela/krom // valge/kroom // balta/hroma // bela/hrom // hvit/krom // бял/хром // e bardhë/krom

**820** = brushed nickel / nikiel szorowany / 镍拉丝 / harjattu nikkeli / borstad nickel / nichel mat / νικελ ματ / børstet nikkel / надраскан никел / nikel i furçuar / نیکل مُفرَش



**Trio / Quattro E** 15931000

**Trio / Quattro S** 15932000

**Trio / Quattro Metris** 31634000

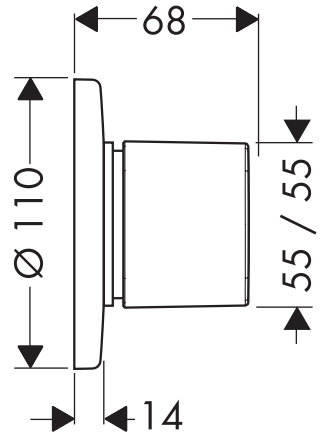
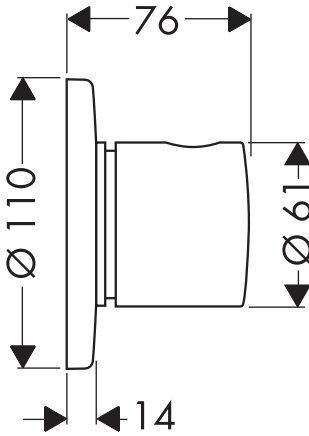
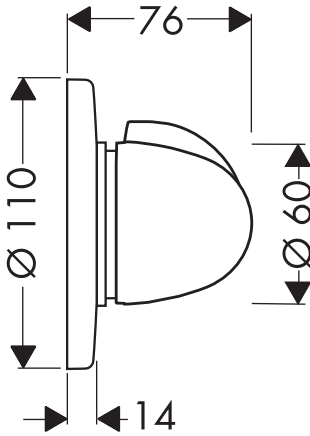

**Trio / Quattro PuraVida** 15937XXX

**Trio / Quattro Classic** 15934XXX

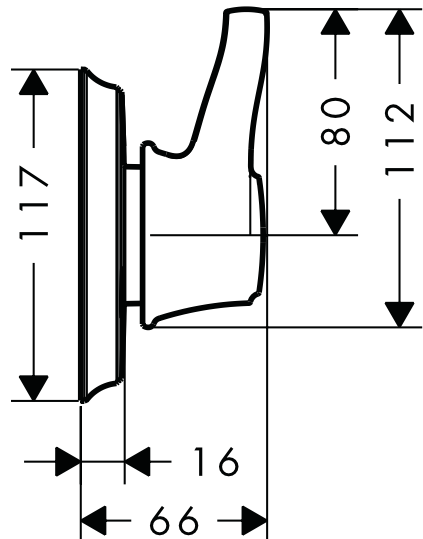
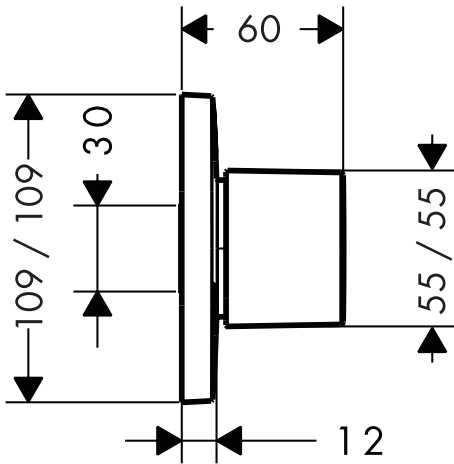



---

	<b>P-IX</b>	<b>DVGW</b>	<b>SVGW</b>	<b>WRAS</b>	<b>KIWA</b>	<b>NF</b>	<b>ACS</b>	<b>ETA</b>
<b>15931000</b>			X	X			X	
<b>15932000</b>			X	X			X	
<b>15934XXX</b>								
<b>15937XXX</b>			X					
<b>31634000</b>								

---

**hansgrohe**

Hansgrohe - Postfach 1145 · D-77761 Schiltach · Telefon +49 (0) 78 36/51-1282 · Telefax +49 (0) 7836/511440  
E-Mail: [info@hansgrohe.com](mailto:info@hansgrohe.com) · Internet: [www.hansgrohe.com](http://www.hansgrohe.com)

4/2011  
9.084.65.07