

DE	Gebrauchsanleitung / Montageanleitung	2
FR	Mode d'emploi / Instructions de montage	2
EN	Instructions for use / assembly instructions	2
IT	Istruzioni per l'uso / Istruzioni per Installazione	2
ES	Modo de empleo / Instrucciones de montaje	3
NL	Gebruiksaanwijzing / Handleiding	3
DK	Brugsanvisning / Monteringsvejledning	3
PT	Instruções para uso / Manual de Instalação	3
PL	Instrukcja obsługi / Instrukcja montażu	4
CS	Návod k použití / Montážní návod	4
SK	Návod na použitie / Montážny návod	4
ZH	用户手册 / 组装说明	4
RU	Руководство пользователя / Инструкция по монтажу	5
HU	Használati útmutató / Szerelési útmutató	5
FI	Käyttöohje / Asennusohje	5
SV	Brugsanvisning / Monteringsanvisning	5
LT	Vartotojo instrukcija / Montavimo instrukcijos	6
HR	Upute za uporabu / Uputstva za instalaciju	6
TR	Kullanım kılavuzu / Montaj kılavuzu	6
RO	Manual de utilizare / Instrucțiuni de montare	6
EL	Οδηγίες χρήσης / Οδηγία συναρμολόγησης	7
SL	Navodilo za uporabo / Navodila za montažo	7
ET	Kasutusjuhend / Paigaldusjuhend	7
LV	Lietošanas pamācība / Montāžas instrukcija	7
SR	Uputstvo za upotrebu / Uputstvo za montažu	8
NO	Brugsanvisning / Montasjeveiledning	8
BG	Инструкция за употреба / Инструкция за употреба	8
SQ	Udhëzuesi i përdorimit / Udhëzime rreth montimit	8
AR	دليل الاستخدام / تعليمات التجميع	9

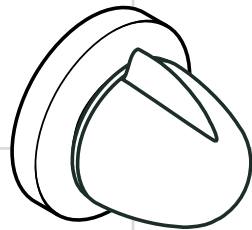

**Metropol E / Metris E /
Talis E² / Focus E / Focus E²**
15971XXX

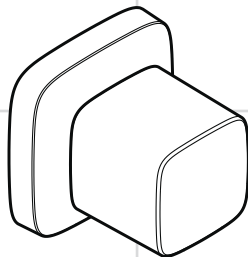

PuraVida
15978XXX

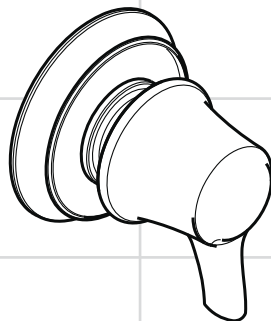

**Metris Classic /
Talis Classic**
15961XXX



Sicherheitshinweise

- Bei der Montage müssen zur Vermeidung von Quetsch- und Schnittverletzungen Handschuhe getragen werden.

Montagehinweise

- Die Armatur muss nach den gültigen Normen montiert, gespült und geprüft werden!



Kein essigsäurehaltiges Silikon verwenden!



Maße (siehe Seite 13)



Serviceteile (siehe Seite 14)

**Montage
siehe Seite 10**



Consignes de sécurité

- Lors du montage, porter des gants de protection pour éviter toute blessure par écrasement ou coupure

Instructions pour le montage

- La robinetterie doit être installée, rincée et contrôlée conformément aux normes valables!



Ne pas utiliser de silicone contenant de l'acide acétique!



Dimensions (voir page 13)



Pièces détachées (voir pages 14)

**Montage
voir page 10**



Safety Notes

- Gloves should be worn during installation to prevent crushing and cutting injuries.

Installation Instructions

- The fitting must be installed, flushed and tested after the valid norms!



Do not use silicone containing acetic acid!



Dimensions (see page 13)



Spare parts (see page 14)

**Assembly
see page 10**



Indicazioni sulla sicurezza

- Durante il montaggio, per evitare ferite da schiacciamento e da taglio bisogna indossare guanti protettivi.

Istruzioni per il montaggio

- La robinetteria deve essere installata, pulita e testata secondo le istruzioni riportate!



Non utilizzare silicone contenente acido acetico!



Ingombri (vedi pagg. 13)



Parti di ricambio (vedi pagg. 14)

**Montaggio
vedi pagg. 10**

**! Indicaciones de seguridad**

- ⚠ Durante el montaje deben utilizarse guantes para evitar heridas por aplastamiento o corte.

Indicaciones para el montaje

- El grifo tiene que ser instalado, probado y testado, según las normas en vigor.



No utilizar silicona que contiene ácido acético!



Dimensiones (ver página 13)



Repuestos (ver página 14)

Montaje
ver página 10

! Veiligheidsinstructies

- ⚠ Bij de montage moeten ter voorkoming van kneel- en snijwonden handschoenen worden gedragen.

Montage-instructies

- Leidingen doorspoelen volgens Norm. De mengkraan vervolgens monteren en controleren!



Gebruik geen zuurhoudende silicone!



Maten (zie blz. 13)



Service onderdelen (zie blz. 14)

Montage
zie blz. 10

**! Sikkerhedsanvisninger**

- ⚠ Ved monteringen skal der bruges handsker for at undgå kvæstelser og snitsår.

Monteringsanvisninger

- Ifølge gældende regler, skal armaturet monteres, skylles igennem og afprøves.



Der må ikke benyttes eddikesyreholdig silikone!



Målene (se s. 13)



Reservedele (se s. 14)

Montering
se s. 10

! Avisos de segurança

- ⚠ Durante a montagem devem ser utilizadas luvas de protecção, de modo a evitar ferimentos resultantes de entalamentos e de cortes.

Avisos de montagem

- A misturadora deve ser instalada, purgada e testada de acordo com as normas em vigor!



Não utilizar silicone que contenha ácido acético!



Medidas (ver página 13)



Peças de substituição (ver página 14)

Montagem
ver página 10





Wskazówki bezpieczeństwa

- △ Aby uniknąć zranień, takich jak zgniecenia czy przecięcia, podczas montażu należy nosić rękawice.

Wskazówki montażowe

- Armatura musi być zamontowana, przepłukana i wypróbowana według obowiązujących norm!



Nie stosować silikonów zawierających kwas octowy!



Wymiary (patrz strona 13)



Części serwisowe (patrz strona 14)

Montaż
patrz strona 10

Bezpečnostní pokyny

- △ Pro zabránění řezným zraněním a pohmožděním je nutné při montáži nosit rukavice.

Pokyny k montáži

- Armatura se musí montovat, proplachovat a testovat podle platných norem!



Nepoužívat silikon s obsahem kyseliny octové!



Rozměry (viz strana 13)



Servisní díly (viz strana 14)

Montáž
viz strona 10



Bezpečnostné pokyny

- △ Pri montáži musíte nosiť rukavice, aby ste predišli pomliaždeninám a rezným poraneniam.

Pokyny pre montáž

- Batéria sa musí montovať, preplachovať a testovať podľa platných noriem!



Nepoužívať silikón s obsahom kyseliny octovej!



Rozmery (viď strana 13)



Servisné diely (viď strana 14)

Montáž
viď strana 10

安全技巧

- △ 装配时为避免挤压和切割受伤，必须戴上手套。

安装提示

- 必须按照现行的规定安装，冲洗和测试产品！



请勿使用含有乙酸的硅！



大小 (参见第 13 页)



备用零件 (参见第14页)

安装
参见第10页





Указания по технике безопасности

-  Во время монтажа следует надеть перчатки во избежание прищемления и порезов.

Указания по монтажу

- Смеситель должен быть смонтирован по действующим нормам и в соответствии с настоящей инструкцией, проверен на герметичность и безупречность работы



Не применяйте силикон, содержащий уксусную кислоту.



Размеры (см. стр. 13)



Комплект (см. стр. 14)

Монтаж
см. стр. 10

Biztonsági utasítások

-  A szerelésnél a zúzódások és vágási sérülések elkerülése érdekében kesztyűt kell viselni.

Szerelési utasítások

- A csaptelepet az érvényben lévő előírásoknak megfelelően kell felszerelni, átöblíteni és ellenőrizni!



Ne használjon ecetsavtartalmú szilikon!



Méretet (lásd a 13. oldalon)



Tartozékok (lásd a 14. oldalon)

Szerelés
lásd a 10. oldalon



Turvallisuusohjeet

-  Asennuksessa on käytettävä käsineitä puristumien ja viiltojen aiheuttamien tapaturmien estämiseksi.

Asennusohjeet

- Kaluste on asennettava, huuhdeltava ja tarkastettava voimassa olevien määräysten mukaisesti!



Älä käytä etikkahappopitoista silikoniala!



Mitat (katso sivu 13)



Varaosat (katso sivu 14)

Asennus
katso sivu 10

Säkerhetsanvisningar

-  Handskar ska bäras under monteringsarbetet så att man kan undvika kläm- och skärskadorgen werden.

Monteringsanvisningar

- Blandaren måste installeras, genomspolas och testas enligt gällande föreskrifter.



Använd inte silikon som innehåller ättiksyra!



Måtten (se sidan 13)



Reservdelar (se sidan 14)

Montering
se sidan 10





Saugumo technikos nurodymai

- ⚠️ Apsaugai nuo užspaudimo ir įsijovavimo montavimo metu mūvėkite pirštines.

Montavimo instrukcija

- Maišytuvus privalo būti montuojamas, išleidžiamas ir patikrinamas pagal galiojančias normas!

Sigurnosne upute

- ⚠️ Prilikom montaže se radi sprječavanja prignječnja i posjekotina moraju nositi rukavice.

Upute za montažu

- Cijevi moraju biti postavljene, isprane i testirane prema važećim normama!



Nenaudokite silikono, kurio sudėtyje yra acto rūgšties!



Išmatavimai (žr. psl. 13)



Atsarginės dalys (žr. psl. 14)

Montavimas
žr. psl. 10



Nemojte koristiti silikon koji sadrži octenu kiselinu!



Mjere (pogledaj stranicu 13)



Rezervni djelovi (pogledaj stranicu 14)

Sastavljanje
pogledaj stranicu 10



Güvenlik uyarıları

- ⚠️ Montaj esnasında ezilme ve kesilme gibi yaralanmaları önlemek için eldiven kullanılmalıdır.

Montaj açıklamaları

- Batarya geçerli normlara göre monte edilmeli, yıkanmalı ve kontrol edilmelidir!

Instrucțiuni de siguranță

- ⚠️ La montare utilizați mănuși pentru evitarea contuziunilor și tăierii mâinilor.

Instrucțiuni de montare

- Bateria trebuie montată, clătită și verificată conform normelor în vigoare.



Asetik asit içeren silikon kullanmayın!



Ölçüleri (Bakınız sayfa 13)



Yedek Parçalar (Bakınız sayfa 14)

Montajı
Bakınız sayfa 10



Nu utilizați silicon cu conținut de acid acetic!



Dimensiuni (vezi pag. 13)



Piese de schimb (vezi pag. 14)

Montare
vezi pag. 10



**⚠ Υποδειξεις ασφαλειας**

⚠ Για να αποφύγετε τραυματισμούς κατά τη συναρμολόγηση πρέπει να φοράτε γάντια.

Οδηγίες συναρμολόγησης

- Η κεντρική βάνα πρέπει να τοποθετηθεί, να πλυθεί και να ελεγχθεί με βάση τους ισχύοντες κανόνες υδραυλικής τέχνης!



Μην χρησιμοποιείτε σιλικόνη που περιέχει οξικό οξύ!



Διαστάσεις (βλ. σελίδα 13)



Ανταλλακτικά (βλ. σελίδα 14)

**Συναρμολόγηση
βλ. σελίδα 10**

⚠ Varnostna opozorila

⚠ Pri montaži je treba nositi rokavice, da se preprečijo poškodbe zaradi zmečkanja ali urezov.

Navodila za montažo

- Armaturu je potrebno montirati, sprati in testirati v skladu z veljavnimi normami!



Ne pas utiliser de silicone contenant de l'acide acétique!



Mere (glejte stran 13)



Rezervni deli (glejte stran 14)

**Montaža
Glejte stran 10.**

**⚠ Ohutusjuhised**

⚠ Kandke paigaldamisel muljumis- ja löikevigastuste vältimiseks kindaid.

Paigaldamisjuhised

- Segisti paigaldamine, loputamine ja kontroll peab toimuma vastavalt kehtivatele normidele!



Ärge kasutage äädikhapet sisaldavat silikooni!



Mõõtude (vt lk 13)



Varuosad (vt lk 14)

**Paigaldamine
vt lk 10**

⚠ Drošības norādes

⚠ Montāžas laikā, lai izvairītos no saspiedumiem un iegriezumiem, nepieciešams nēsāt cimdus.

Norādījumi montāžai

- Armatūra jāuzstāda, jāizskalo un jāpārbauda atbilstoši spēkā esošajām normām!



Neizmantot silikonu, kas satur etiķskābi!



Izmērus (skat. 13. lpp.)



Rezerves daļas (skat. 14. lpp.)

**Montāža
skat. 10. lpp.**





Sigurnosne napomene

- ⚠ Prilikom montaže se radi sprečavanja prignječenja i posekotina moraju nositi rukavice.

Instrukcije za montažu

- Armatura mora biti postavljena, isprana i testirana prema važećim normama!



Nemojte koristiti silikon koji sadrži sircetnu kiselinu!



Mere (vidi stranu 13)



Rezervni delovi (vidi stranu 14)

**Montaža
vidi stranu 10**



Sikkerheshenvisninger

- ⚠ Bruk hansker under montasjen for å unngå klem- og kuttskader.

Montagehenvisninger

- Armaturen skal monteres iht. gyldige standarder. De skal spyles og sjekkes!



Ikke bruk silikon som inneholder eddiksyrel!



Mål (se side 13)



Serviceleder (se side 14)

**Montasje
se side 10**



Указания за безопасност

- ⚠ При монтажа трябва да се носят ръкавици, за да се избегнат наранявания поради притискане или порязване.

Указания за монтаж

- Арматурата трябва да се монтира, промие и провери в съответствие с валидните норми!



Не използвайте силикон, съдържащ оцетна киселина!



Размери (вижте стр. 13)



Сервизни части (вижте стр. 14)

**Монтаж
вижте стр. 10**



Udhëzime sigurie

- ⚠ Për të evituar lëndimet e pickimeve ose të prerjeve gjatë procesit të montimit duhet që të vishni doreza.

Udhëzime për montimin

- Armatura duhet montuar, shpërlarë dhe kontrolluar në bazë të normave të vlefshme!



Mos përdorni silikon që në përbërje ka acid acetik.



Përmasat (shih faqen 13)



Pjesë ndërrimi (shih faqen 14)

**Montimi
shih faqen 10**



تنبيهات الأمان



⚠ يجب إرتداء قفازات الليد أثناء التركيب لتجنب حدوث أخطار الإنحشار أو الجروح.

تعليمات التركيب

- يجب تركيب الوصلة، وغمرها بالماء واختبارها وفقاً للمعايير السارية!

هام! لا تستخدم السليكون الذي يحتوي على أحماض!



أبعاد (راجع صفحة 13)

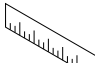

قطع الغيار (راجع صفحة 14)

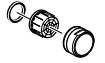

التركيب

راجع صفحة 10



13973180 / 13974180 / 13975180
07/92 - 04/01

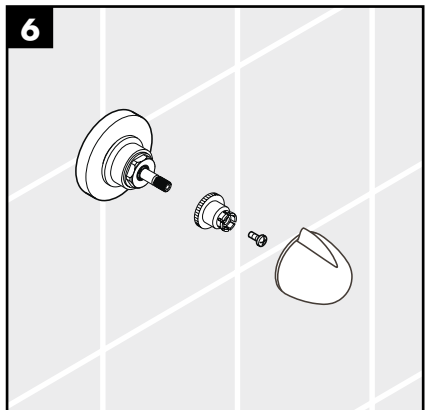
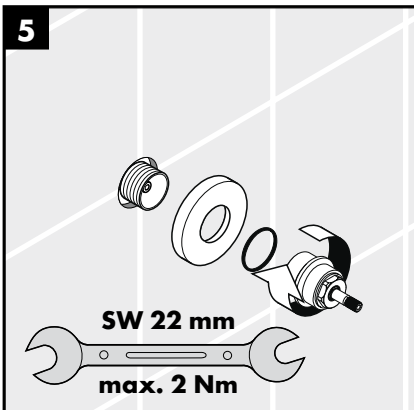
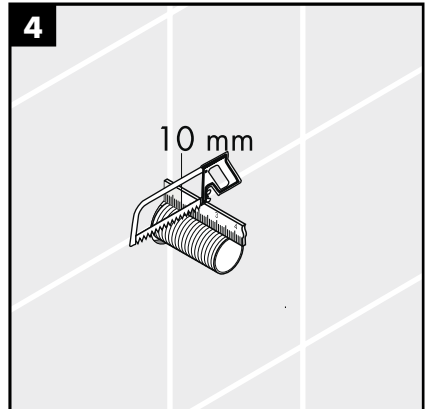
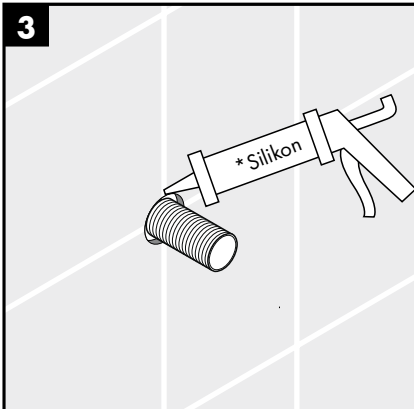
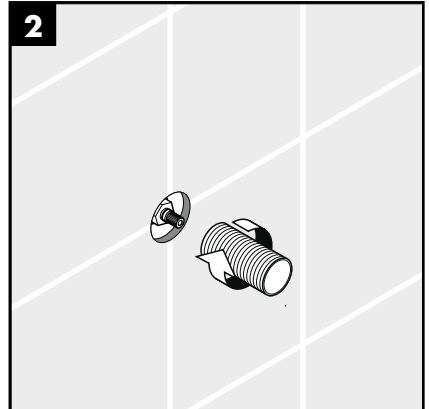
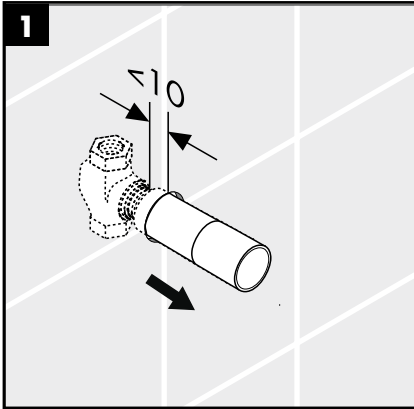



13973180 / 13974180 / 13975180
07/92 - 04/01

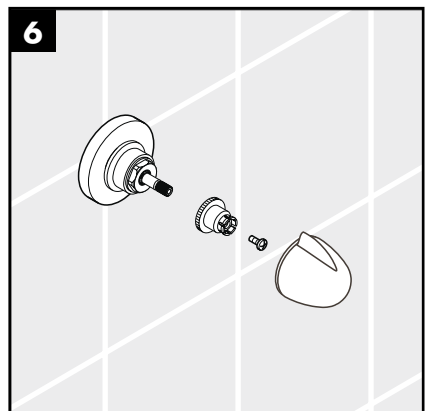
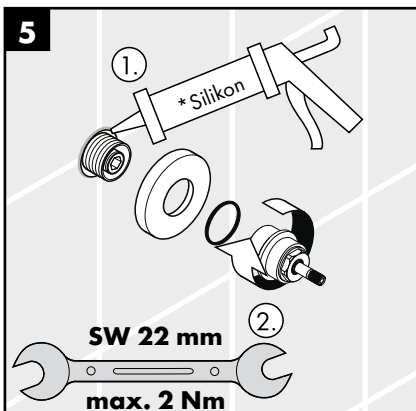
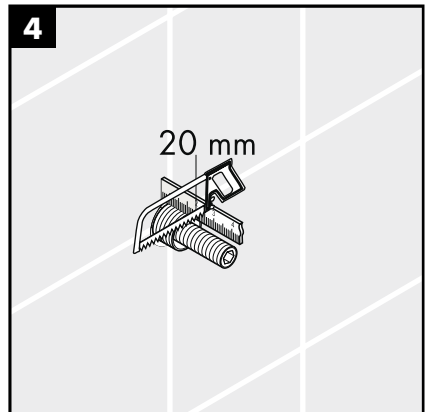
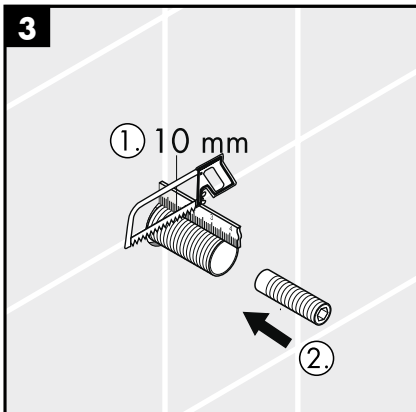
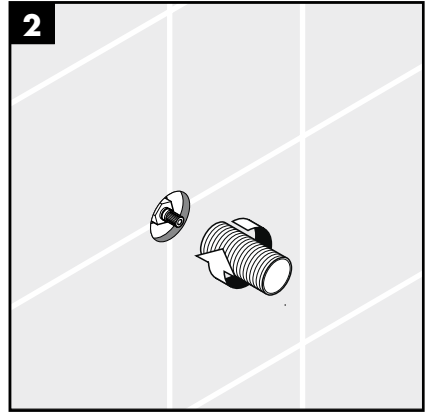
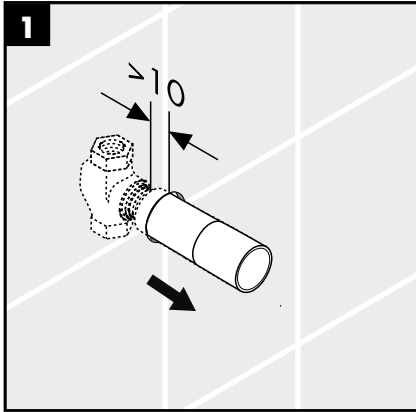



15970180 / 15973180 / 15974180
> 05/01

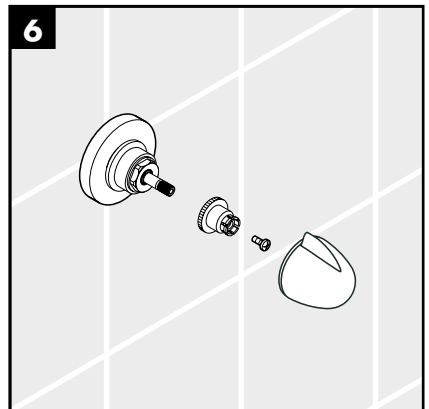
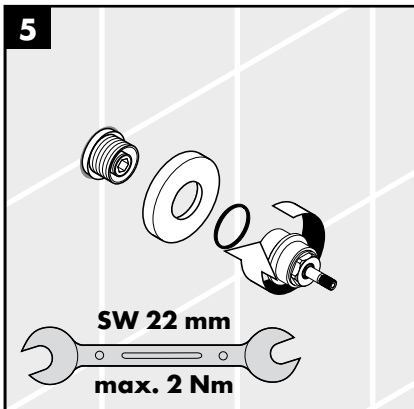
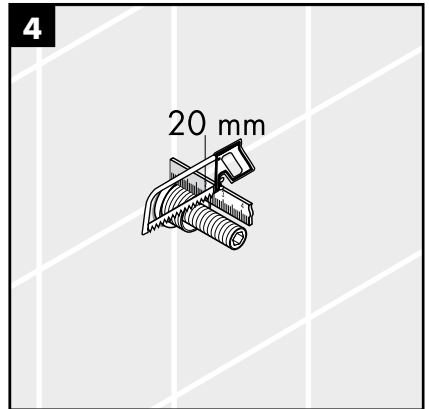
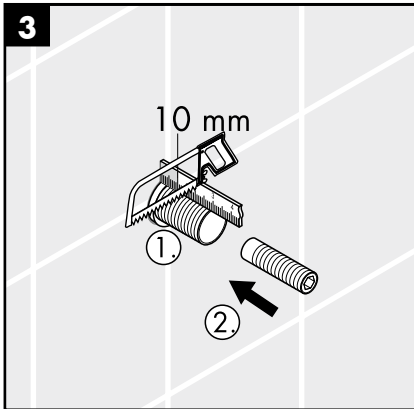
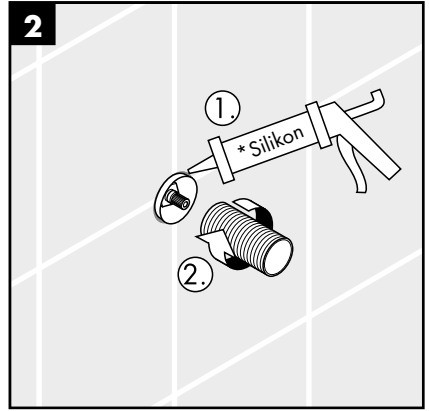
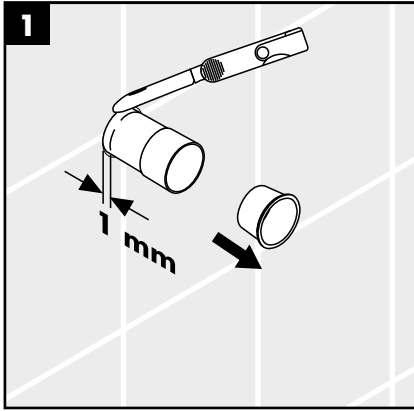

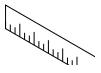

15971XXX

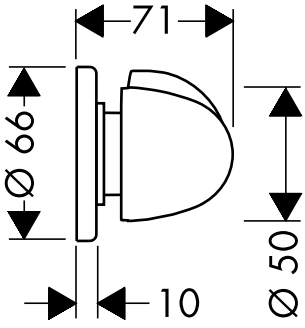

15978XXX

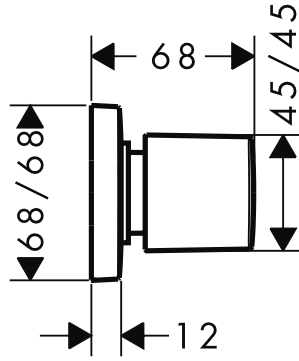

15961XXX

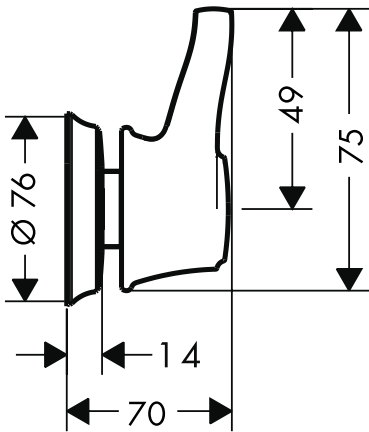

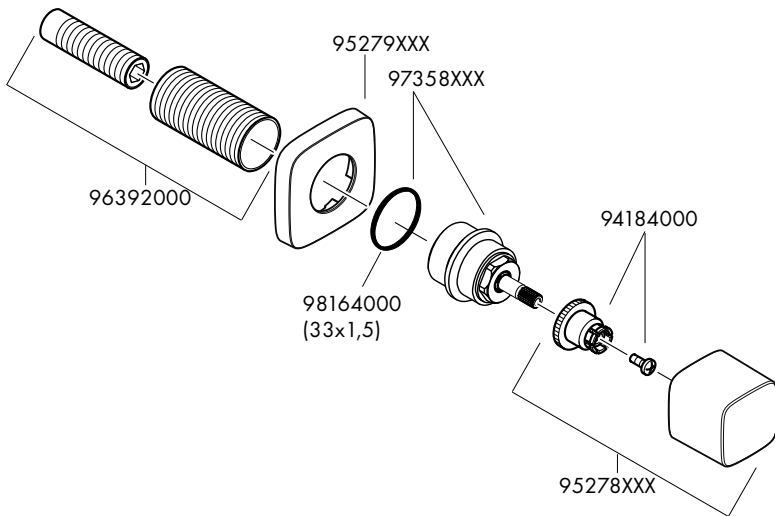
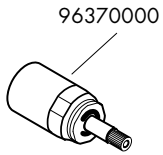
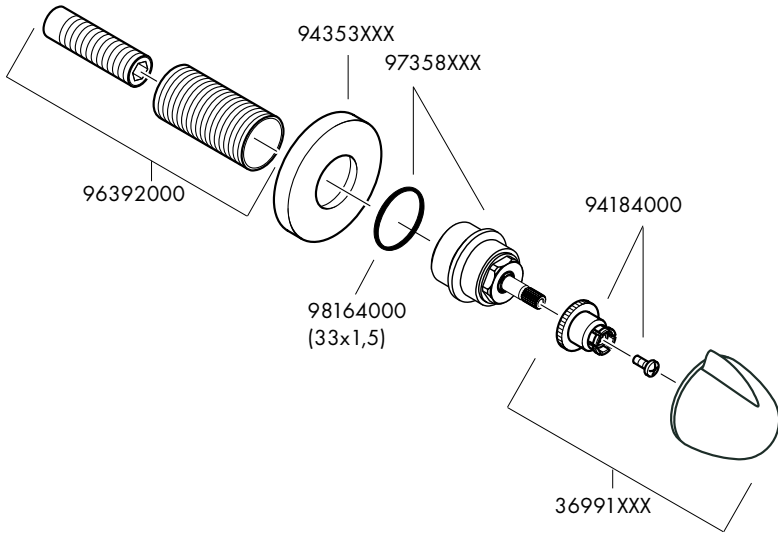

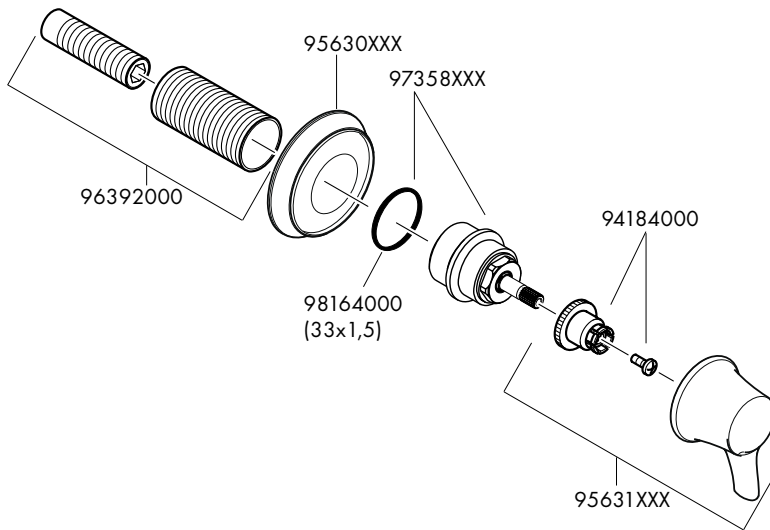

XXX = Farbcodierung // Couleurs // Colors // Trattamento // Acabados // Kleuren // Overflade // Acabamentos // Kody kolorów // Kód povrchové úpravy // Farebné označenie // 颜色代码 // Цветная кодировка // Színkódolás // Värikoodus // Färgkodning // Spalvos // Boje // Renkler // Coduri de culori // Χρώματα // الألوان // Barve // Värvid // Krásu kodi // Oznake boja // Fargekode // Цветово кодиране // Kodimi me anë të ngjyrave

000 = chrom // chromé // chrome plated // cromato // cromado // verchromd // Krom // cromado // chróm // 镀铬 // хром // króm // kromi // krom // crom // Επιχρωμιωμένο // آروم // kroom // hroma // hrom // хром

090 = chrom/gold-optik // chromé/or l'optique // chrome plated/gold plated // cromo/dorado ottica // cromo/oro óptica // chrom/verguld-look // Krom/guld optic // cromado/ouro ótica // chrom/zloty szlachetna // chrom/zlato ocel // chróm/zlato ocel // 镀铬/黑色 // хром/глянцевое золото // króm/arany-hatású // kromi/kultaoptikka // krom/guld-optik // chrominé (aukso optika) // optika krom/zlato // krom/altin-optik // crom/auriu optic // Επιχρωμιωμένο/οπτική χρυσού // آروم/لون ذهبي // krom/pozlačena // kroom/kuld optik // hroma/zelta // dezer hrom/zlatna // krom/gull-optikk // хром/оптика за zlato // krom/i arte-optike

400 = weiß/chrom // blanc/chromé // white/chrome plated // bianco/cromato // blanco/cromado // wit/verchromd // Hvid/Krom // branco/cromado // biaty/chrom // bílá/chrom // biela/chróm // 白色/镀铬 // белый/хром // fehér/króm // valkoinen/kromi // vit/krom // balta/chrom // bijela/krom // beyaz/Krom // alb/crom // λευκό/Επιχρωμιωμένο // أبيض/آروم // bela/krom // valge/kroom // balta/hroma // bela/hrom // hvit/krom // бял/хром // e bardhë/krom

820 = brushed nickel // Brushed nickel // nikiel szorowany // 镍拉丝 // harjattu nikkeli // borstad nickel // nichel mat // νικελ ματ // نیکل مفرش // børstet nikkel // надраскан никел // nikel i furçuar

880 = edelmatt // chromé mat // satin chrome // satinato // satinado // mat // Matkrom // cromado mate // chrom mat // matný chrom // matný chróm // 铬压光 // матовый // mattkróm // jalomatta kromi // ädelmatt // chrominé matiné // matirani krom // Mat/Krom // crom mat // ματ // آروم أملس // krom mat // väärismatt // hroměts matěts // zagasita // edelmatt // блат. матов // mat i çmuar

hansgrohe

Hansgrohe - Postfach 1145 · D-77761 Schiltach · Telefon +49 (0) 78 36/51-1282 · Telefax +49 (0) 7836/511440
E-Mail: info@hansgrohe.com · Internet: www.hansgrohe.com

2/2010
9.084.64.03