

Montageanleitung

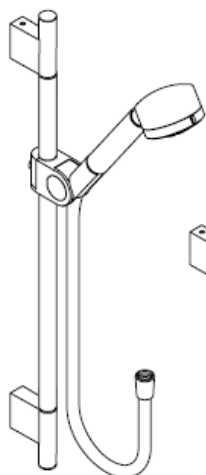

Uno/Arco
27985XXX

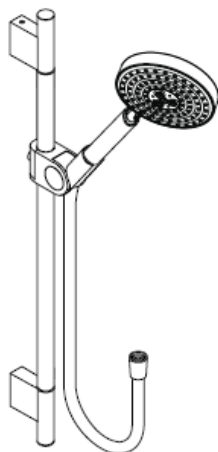

Uno²
27986XXX

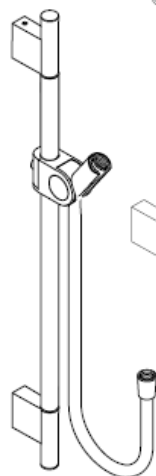

Uno
27989XXX

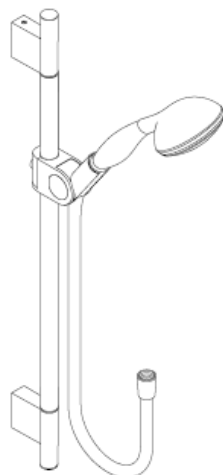

Allegroh
27956000

AXOR®

hansgrohe

Uno/Arco 27985XXX

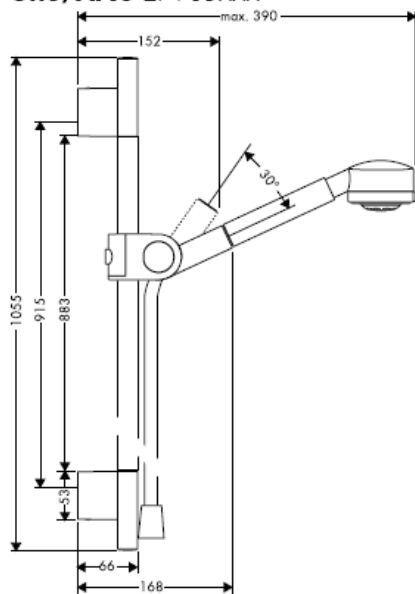

Uno² 27986XXX

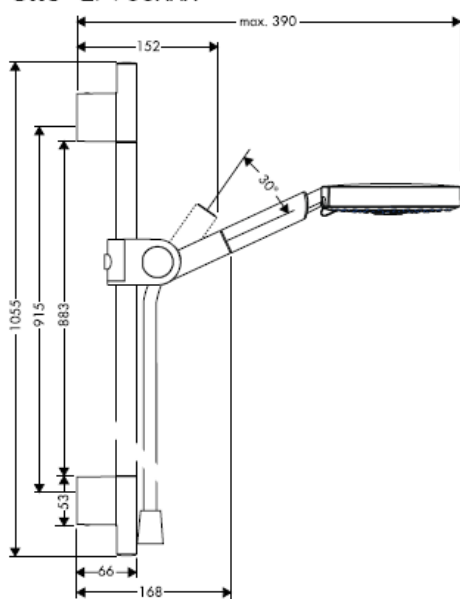

Uno 27989XXX

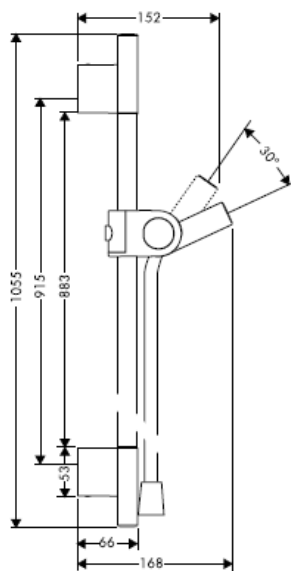

Allegroh 27956000

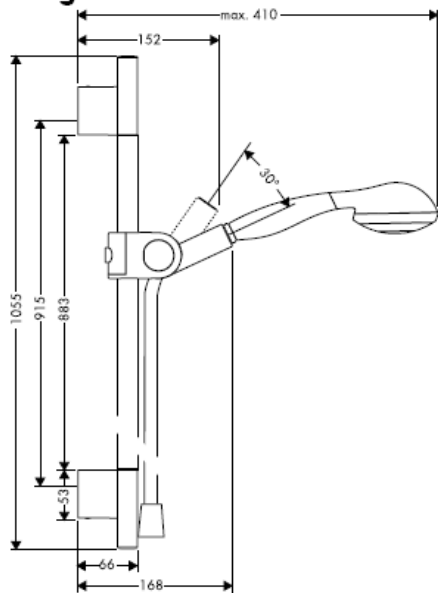



Optimale Funktion nur in Verbindung mit Hansgrohe Handbrausen und Hansgrohe Brausenschläuchen garantiert. Brausenschläuche sind nur zum Anschluss von Brausen an Armaturen geeignet. Eine Absperrung nach dem Schlauch in Fließrichtung ist unzulässig!

Technische Daten

Betriebsdruck:	max. 0,6 MPa
Empfohlener Betriebsdruck: (1 MPa = 10 bar = 147 PSI)	0,1 – 0,4 MPa
Heißwassertemperatur:	max. 60° C

Die Handbrause ist für den Einsatz mit Durchlauferhitzern ab einer Leistung von 21 kW und einem Mindestdurchfluss von 7 l/min geeignet.

Uno/Arco 27985XXX

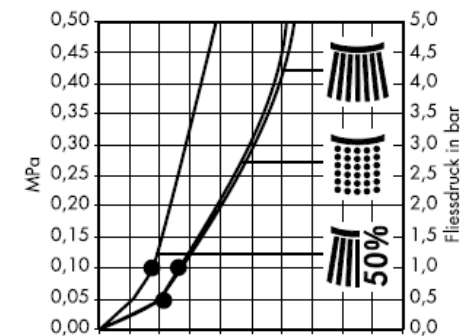
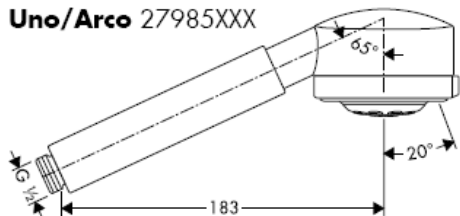

Normalstrahl



Softstrahl



Ecostrahl

Allegroh 27956000

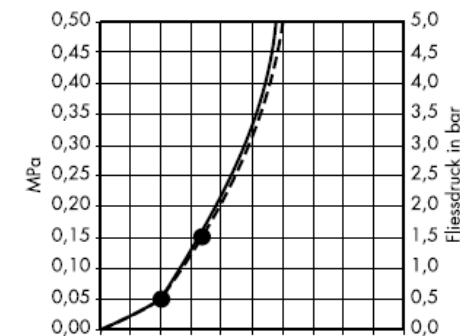
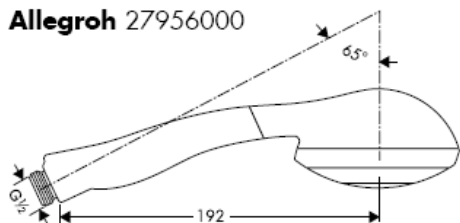

Normalstrahl



Softstrahl

Uno² 27986XXX

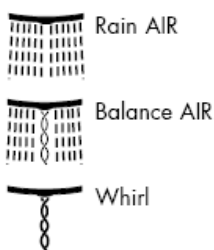
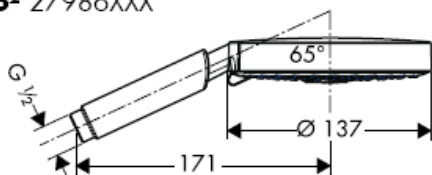

Mit Filtereinsatz (A)

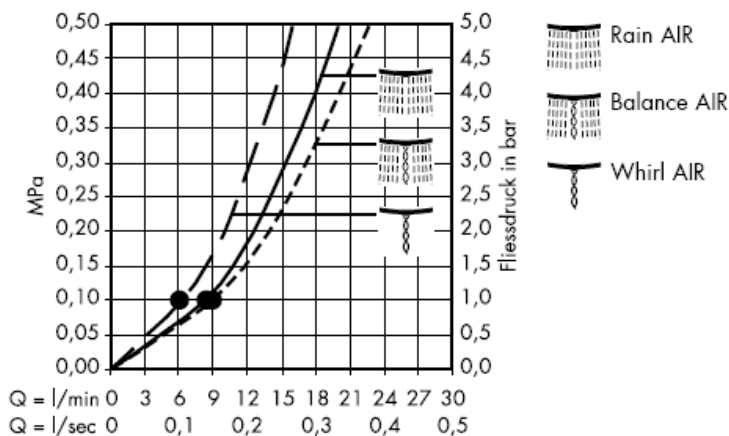

Mit Siebdichtung (B)

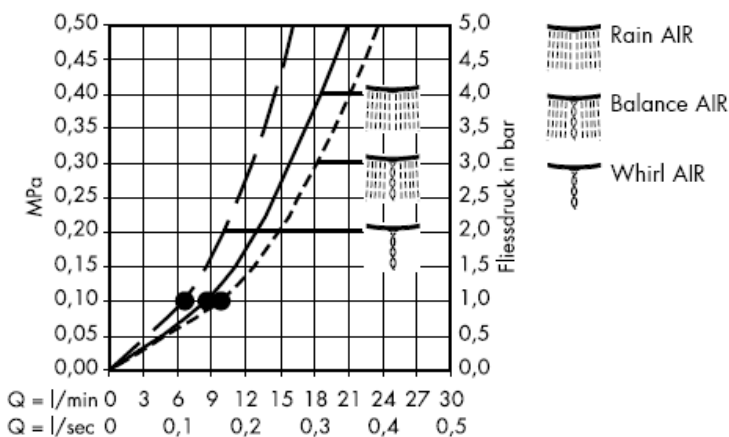

Ab • ist die Funktion gewährleistet.

Maße möglichst dem Fliesenraster anpassen.

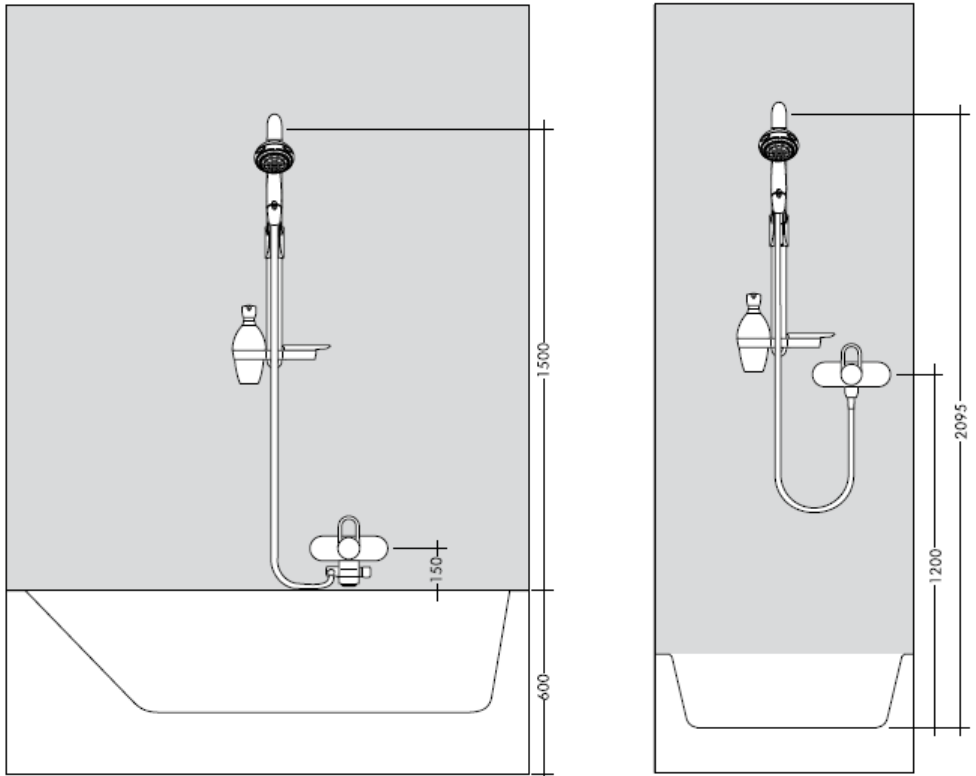

Bei der Montage des Produktes durch qualifiziertes Fachpersonal ist darauf zu achten, dass die Befestigungsfläche im gesamten Bereich der Befestigung plan ist (keine vorstehenden Fugen oder Fliesenversatz), der Wandaufbau für eine Montage des Produktes geeignet ist und insbesondere keine Schwachstellen aufweist.

Die beigelegten Schrauben und Dübel sind nur für Beton geeignet. Bei anderen Wandaufbauten sind die Herstellerangaben des Dübelherstellers zu beachten.

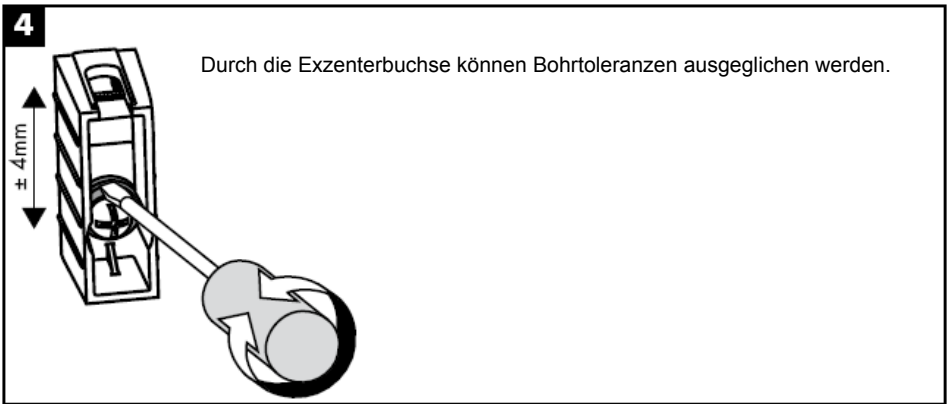
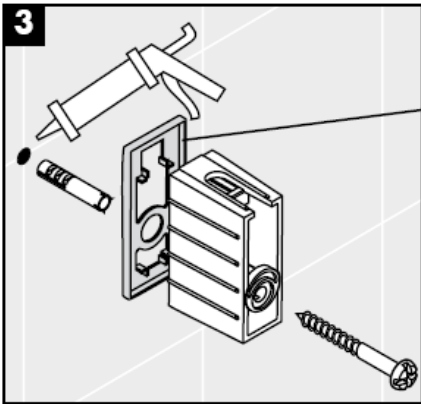
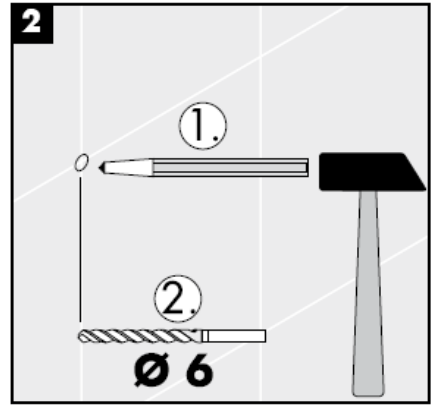
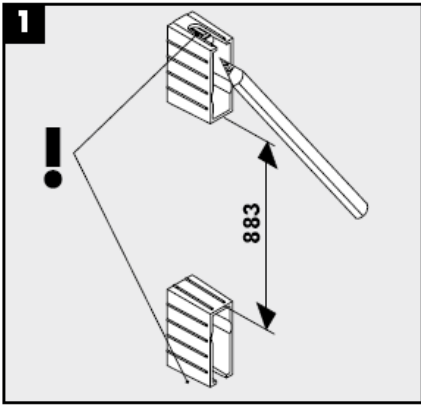

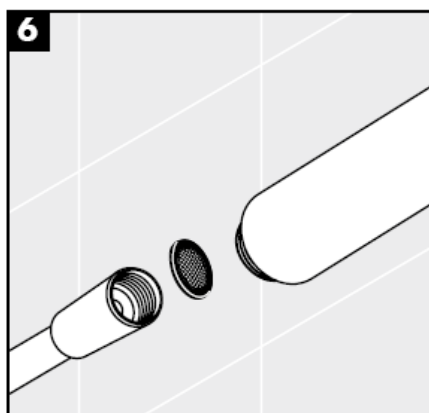
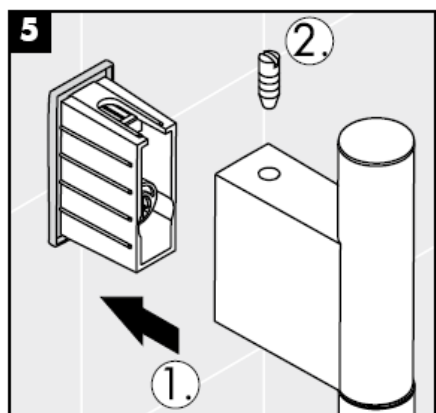

Die der Brause beige packte Siebdichtung muss eingebaut werden, um Schmutzeinspülungen aus dem Leitungsnetz zu vermeiden. Schmutzeinspülungen können die Funktion beeinträchtigen und/oder zu Beschädigungen an Funktionsteilen der Brause führen, für hieraus ergebende Schäden haftet Hansgrohe nicht.

Der beige packte Filtereinsatz (A) muss eingebaut werden, um den Normdurchfluss der Handbrause zu gewährleisten und um Schmutzeinspülungen aus dem Leitungsnetz zu vermeiden. Wird ein größerer Wasserdurchfluss gewünscht, muss anstelle des Filtereinsatzes (A) die Siebdichtung (B) eingesetzt werden.

Schmutzeinspülungen können die Funktion beeinträchtigen und/oder zu Beschädigungen an Funktionsteilen der Handbrause führen, für hieraus ergebende Schäden haftet Hansgrohe nicht.

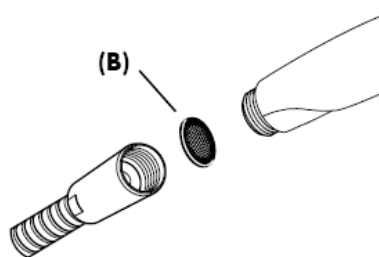
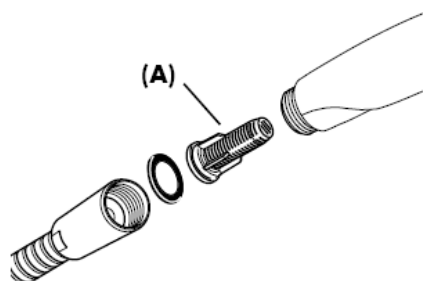

Einjustieren

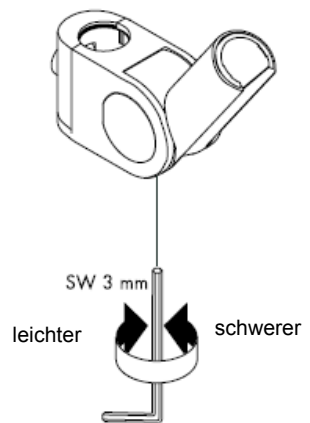
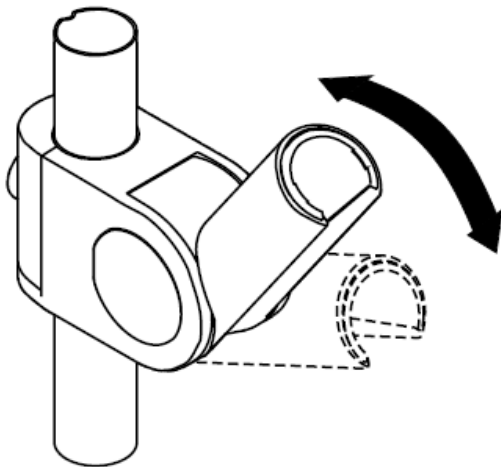
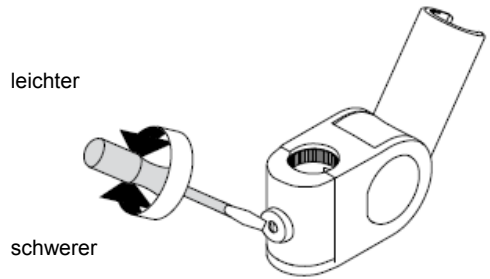
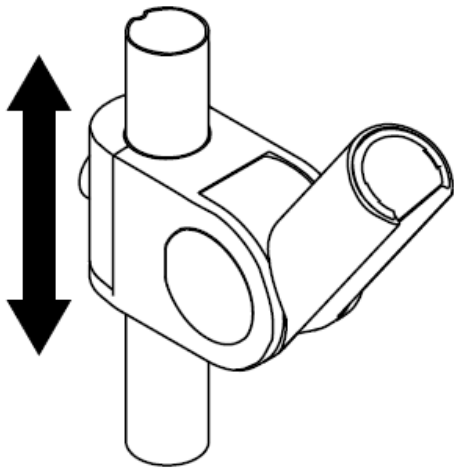

Reinigung

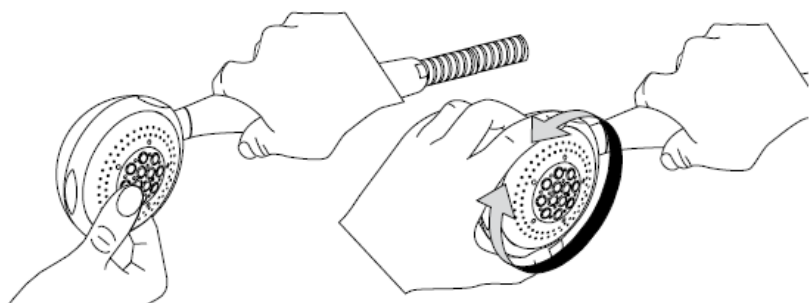

Mit Rubit®, der manuellen Reinigungsfunktion können die Strahlformer durch einfaches rubbeln vom Kalk befreit werden.

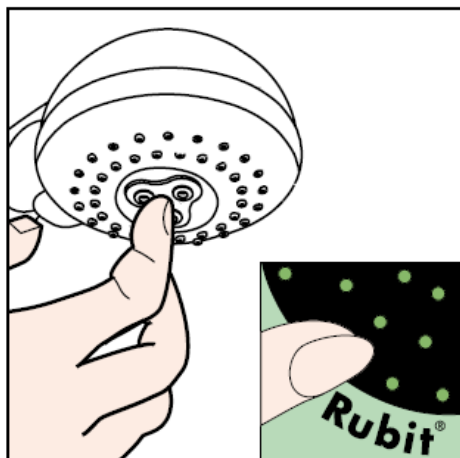

Pflegeanleitung

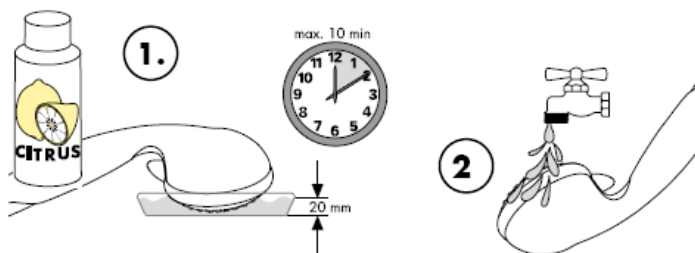

Reinigung

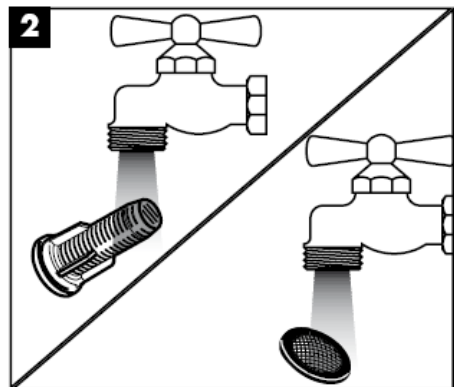
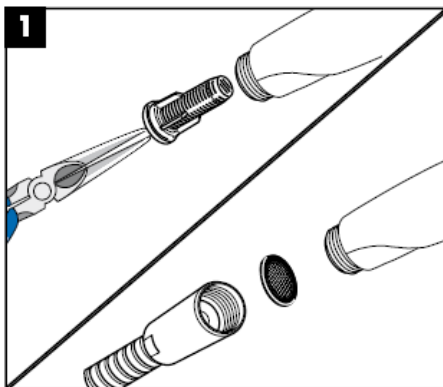
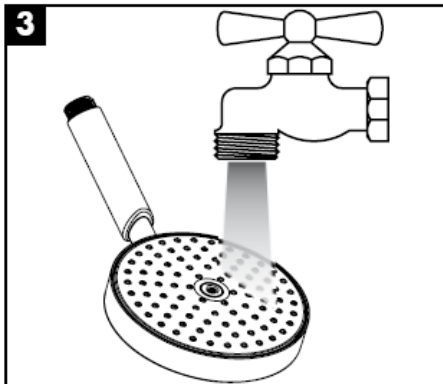
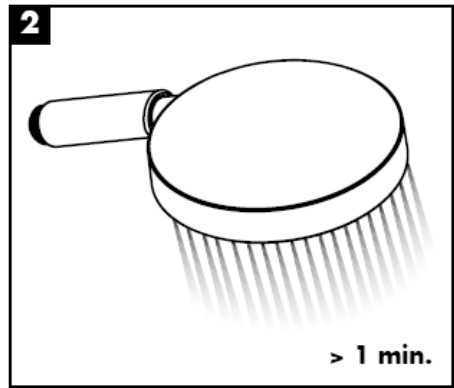
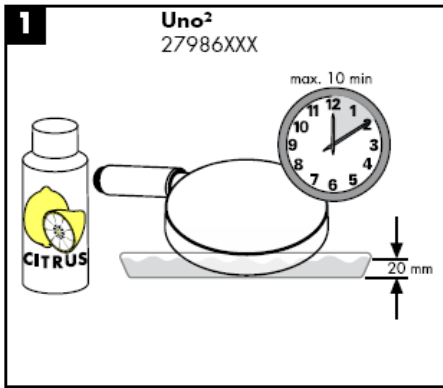

hansgrohe

Instructions de montage

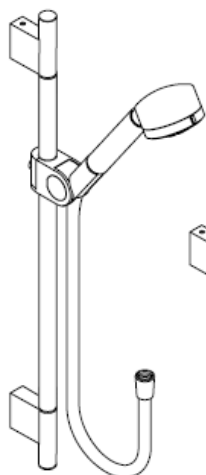

Uno/Arco
27985XXX

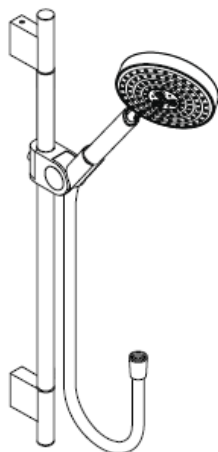

Uno²
27986XXX

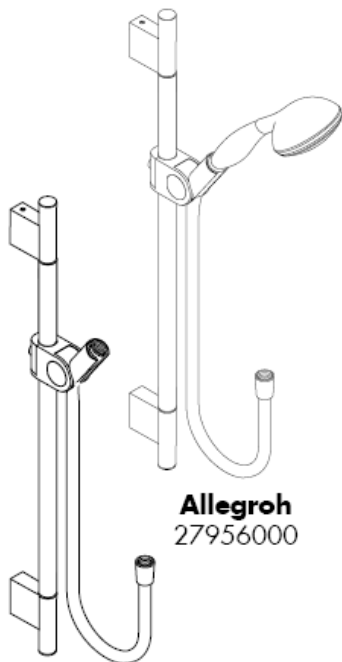

Allegroh
27956000

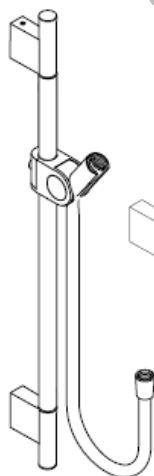

Uno
27989XXX

AXOR®

hansgrohe

Uno/Arco 27985XXX

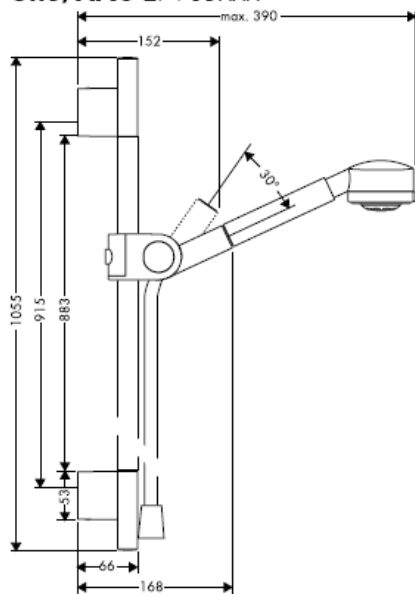

Uno² 27986XXX

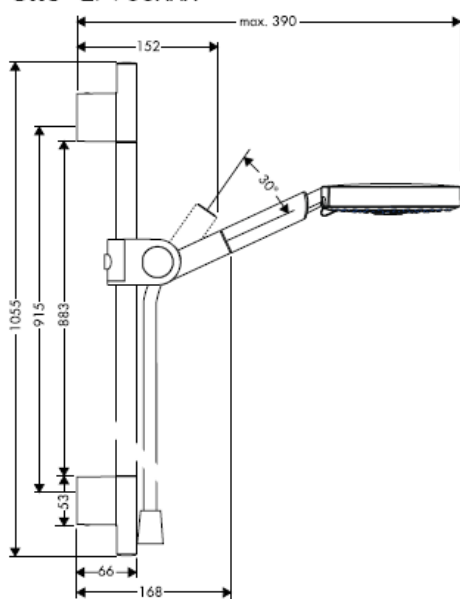

Uno 27989XXX

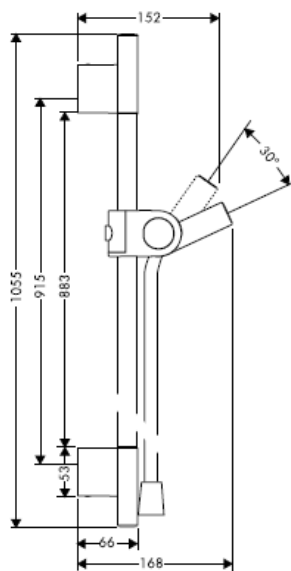

Allegroh 27956000

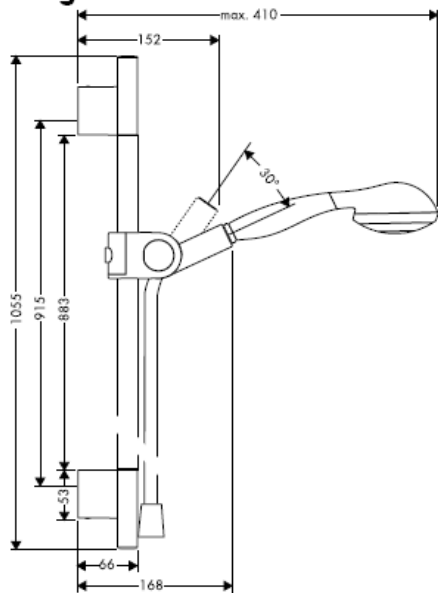



Un fonctionnement optimal est seulement garanti en combinaison avec des douches à main et des flexibles Hansgrohe. Les flexibles de douche ne doivent être utilisés que pour le raccordement d'une douche à main à un robinet. Le montage d'un système d'arrêt après le flexible, en direction du courant d'eau est strictement interdit.

Informations techniques

Pression de service autorisée: max. 0,6 MPa
Pression de service conseillée: 0,1 – 0,4 MPa
(1 MPa = 10 bar = 147 PSI)
Température max. d'eau chaude: max. 60° C

La douchette à main fonctionne avec chauffe-eau à partir de 21 kW et un débit minimum de 7 l/min.

Uno/Arco 27985XXX

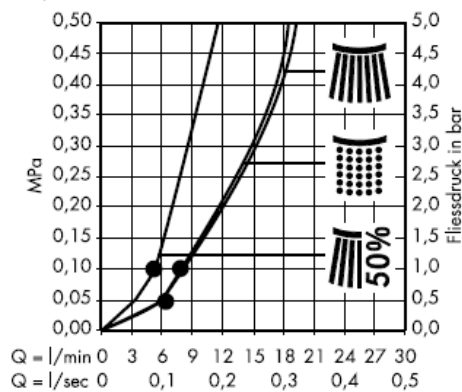
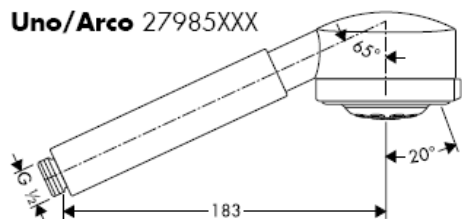

Jet de pluie



Jet doux aéré



Jet de eco

Allegroh 27956000

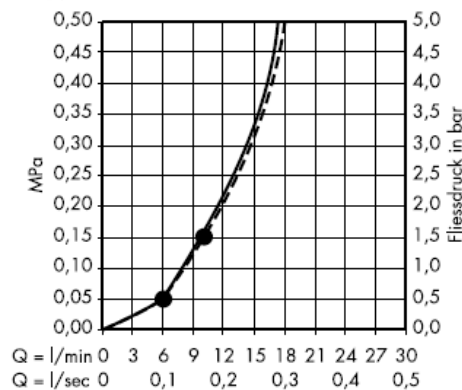
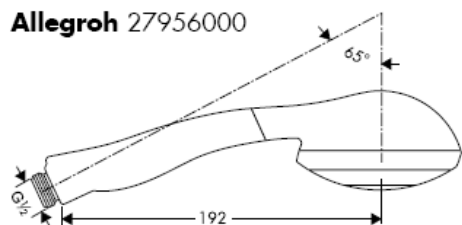

Jet de pluie



Jet doux aéré

Uno² 27986XXX

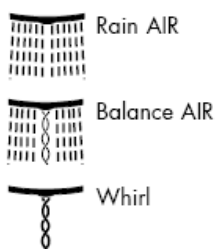
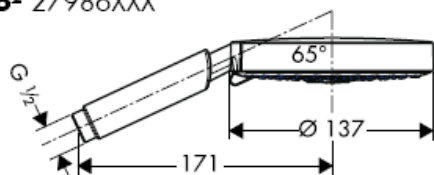

Avec élément-filtre (A)

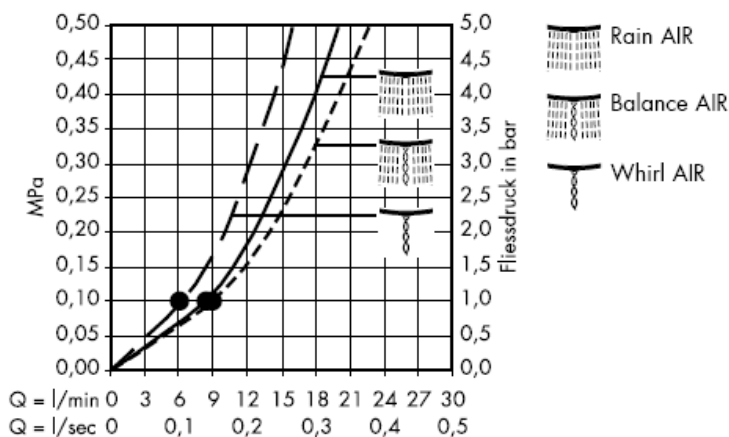

Avec joint- filtre (B)

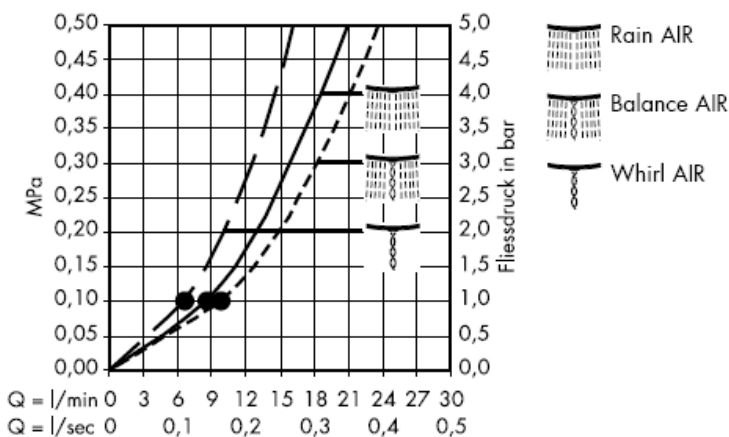

A partir de • le fonctionnement est garanti.

Adapter si possible, les mesures à la dimension des carreaux.

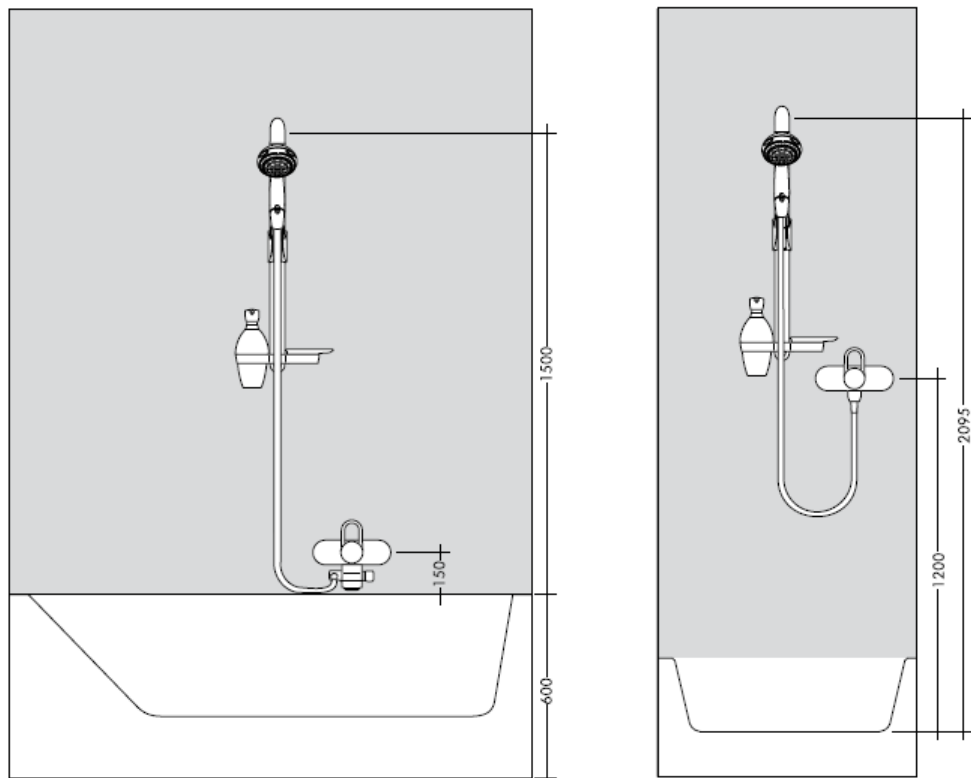

Lors du montage du produit par un ouvrier qualifié, il faut faire attention à ce que la surface de fixation soit plane sur toute son étendue (aucun dépassement de joint ni de carrelage), que la construction de la paroi soit adaptée à l'installation du produit et surtout ne présente aucun point faible. Les vis et les chevilles fournies sont uniquement appropriées au béton. Pour les autres constructions, il faudra tenir compte des préconisations du fabricant de cheville.

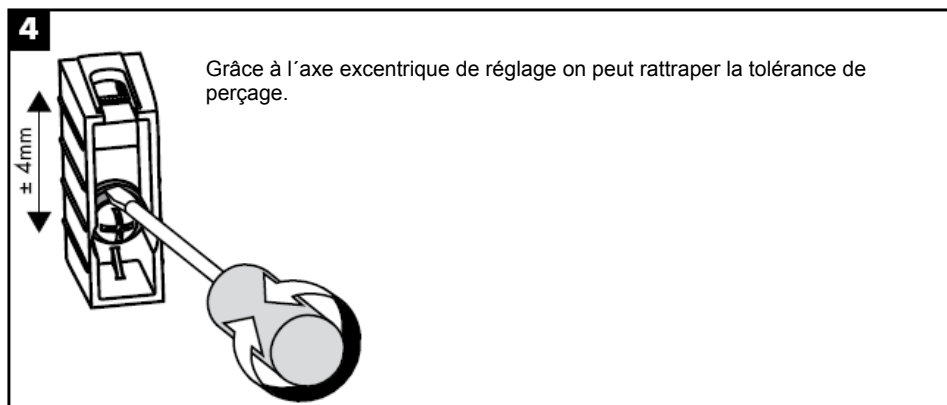
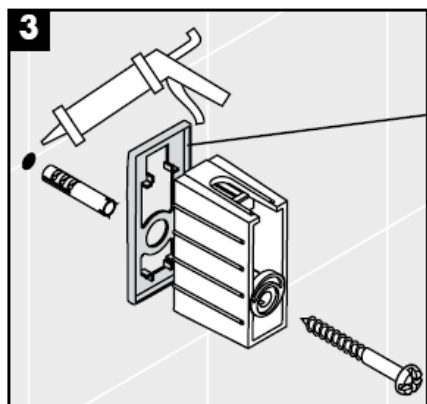
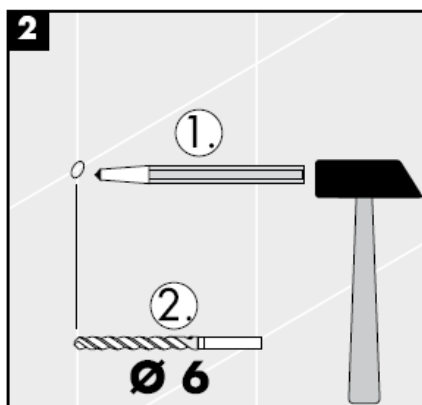
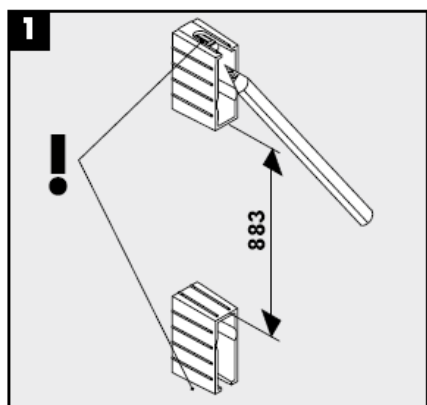

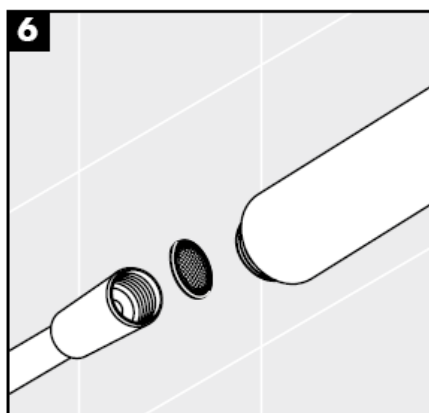
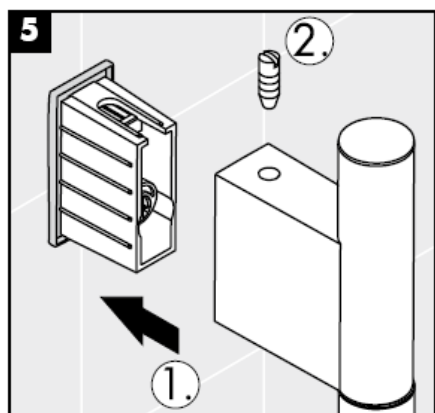

Le joint à filtre fourni avec la pomme de douche à main doit être installé afin de retenir des impuretés du système de conduites. Ceux-ci pourraient influencer le fonctionnement de ce produit et même endommager des pièces mobiles. Des réclamations à la suite de l'usage de la pomme de douche sans joint-tamis de Hansgrohe ne peuvent pas faire partie de notre garantie.

L'élément-filtre (A), pièce jointe, doit être installé pour garantir le débit normalisé et pour éviter l'infiltration d'impuretés venant du réseau. Si l'on désire un débit plus important, il faut remplacer l'élément-filtre (A) par le joint-filtre (B).

L'infiltration d'impuretés peut réduire ou détériorer le fonctionnement de la douchette, Hansgrohe ne se porte pas garant pour les dommages en résultant.

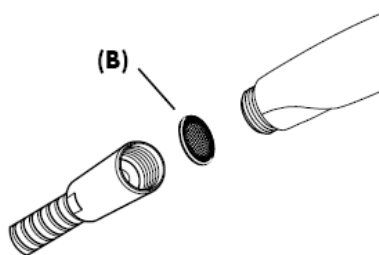
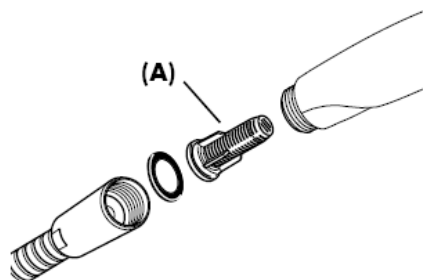

Réglage

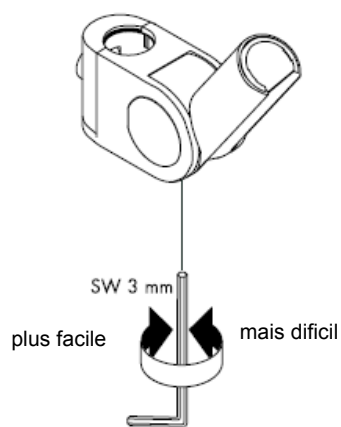
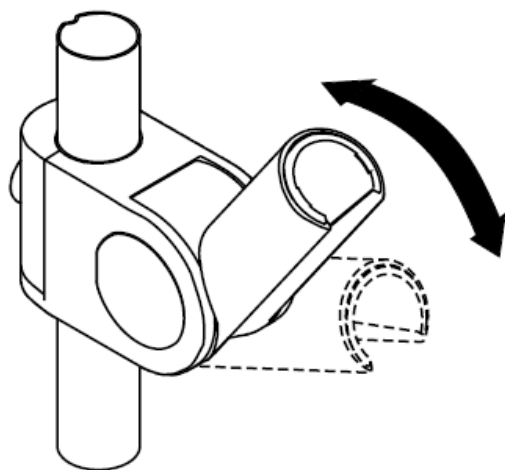
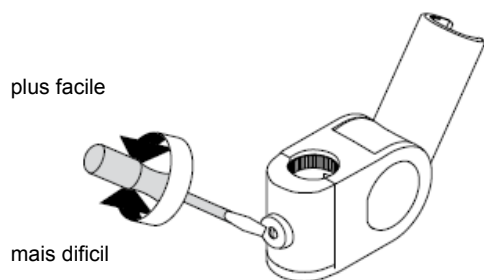
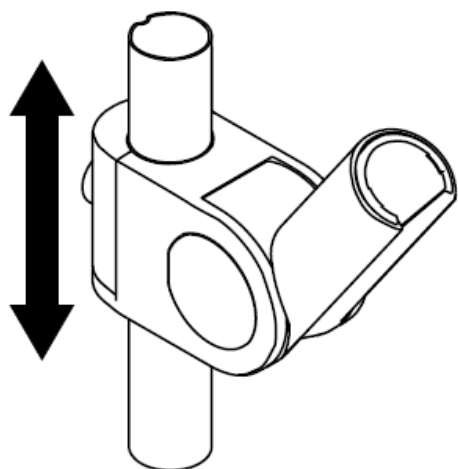

Nettoyage

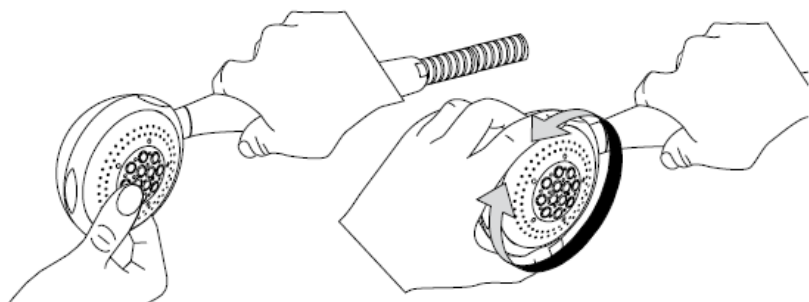

La pomme de douche est équipée de Rubit®, le système anticalcaire manuel. Les dépôts de calcaire s'enlèvent en frottant avec un doigt ou avec une éponge sur les ouvertures de jets élastiques.

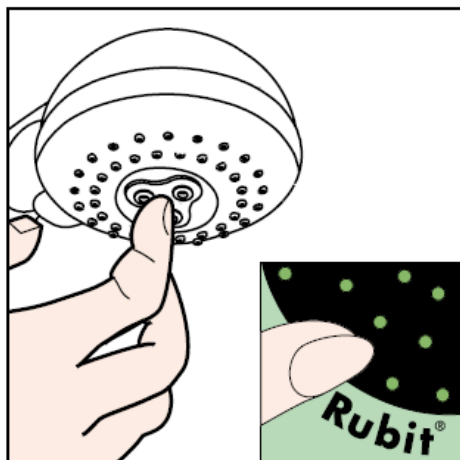

Conseils d'entretien

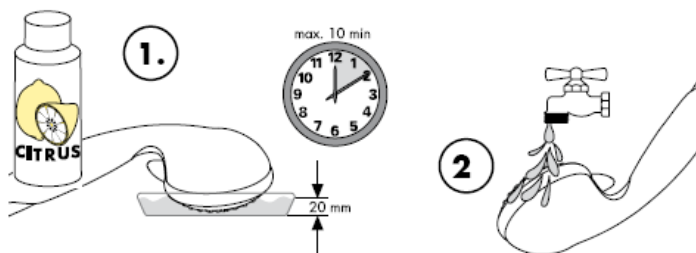

Cleaning

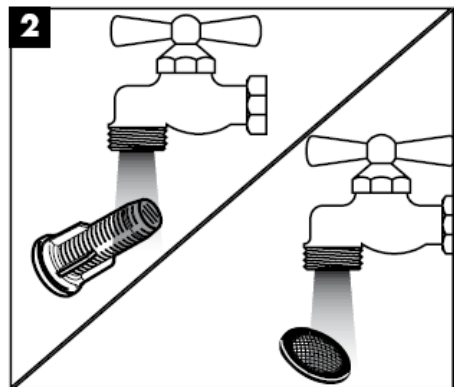
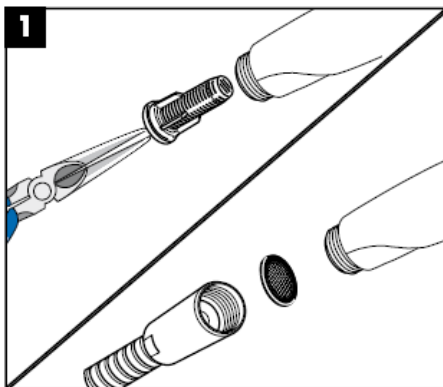
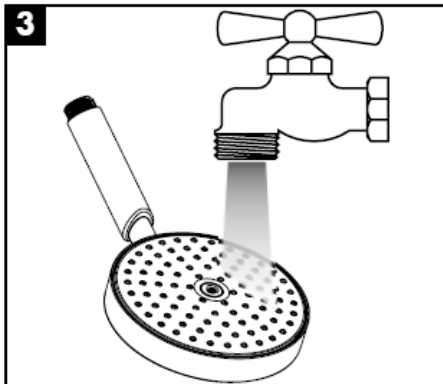
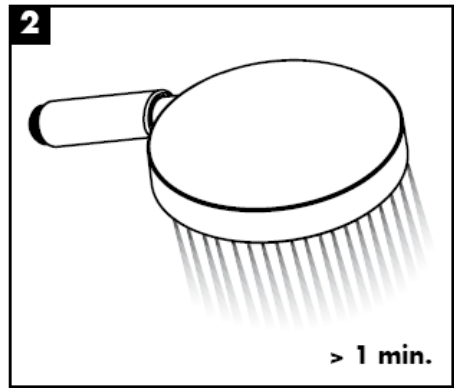
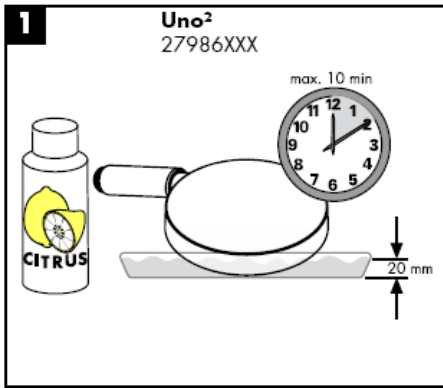

hansgrohe

assembly instructions

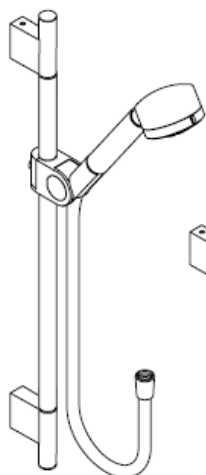

Uno/Arco
27985XXX

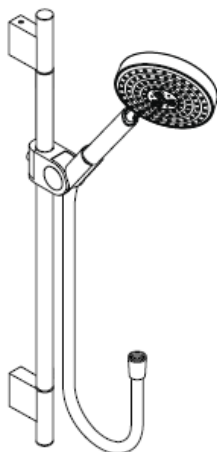

Uno²
27986XXX

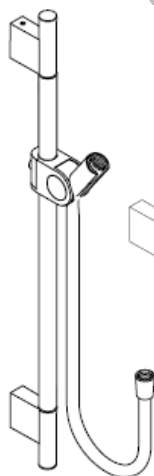

Uno
27989XXX

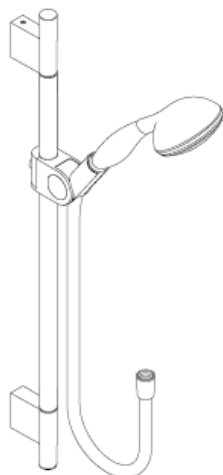

Allegroh
27956000

AXOR®

hansgrohe

Uno/Arco 27985XXX

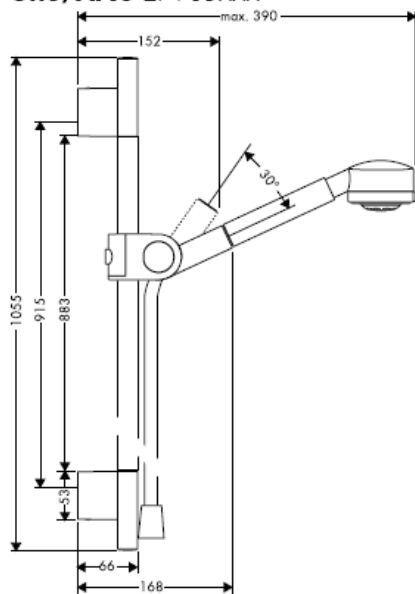

Uno² 27986XXX

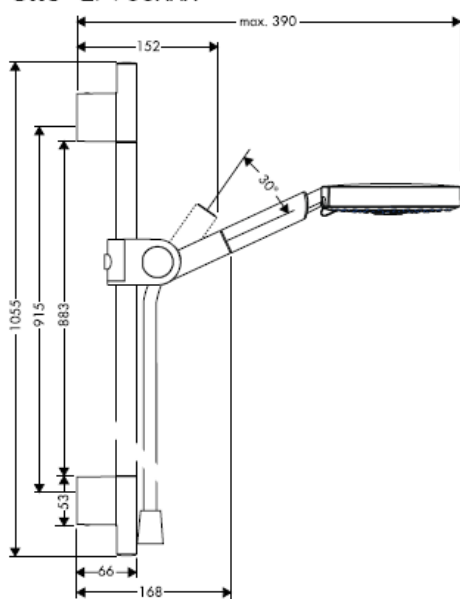

Uno 27989XXX

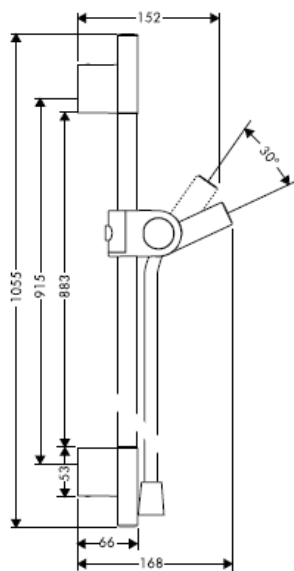

Allegroh 27956000

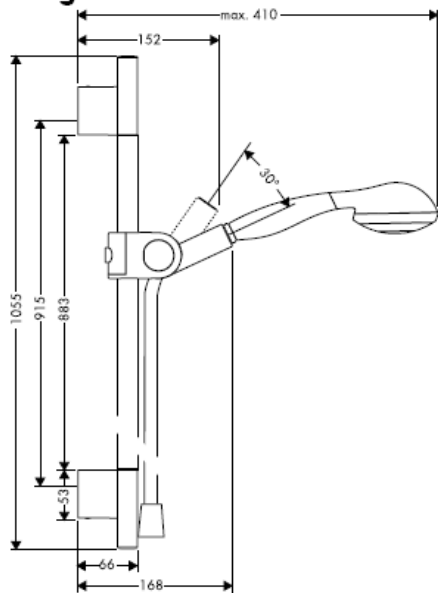



Optimal functioning is only guaranteed with the combination of Hansgrohe hand showers and Hansgrohe shower hoses. Shower hoses are only suitable for a connection from the shower to the fitting. Never fit a shut-off device between the fitting and the hose.

Technical Data

Operating pressure: max. 0,6 MPa
Recommended operating pressure: 0,1 – 0,4 MPa
(1 MPa = 10 bar = 147 PSI)
Hot water temperature: max. 60° C

The hand shower is suitable for continuous flow water heaters with a heat output of 21 kW and a minimum through flow of 7 l/minute.

Uno/Arco 27985XXX

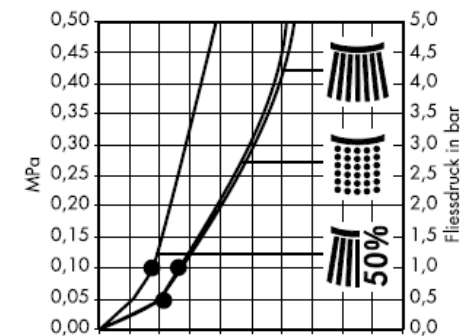
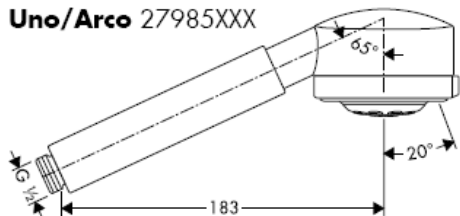

Normal spray



Soft spray



Massage jet

Allegroh 27956000

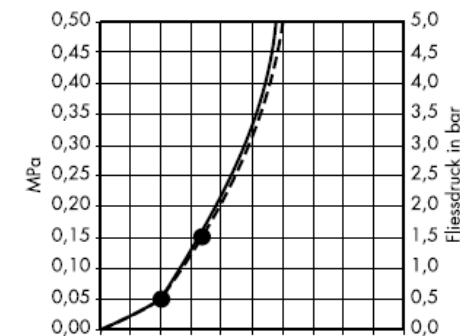
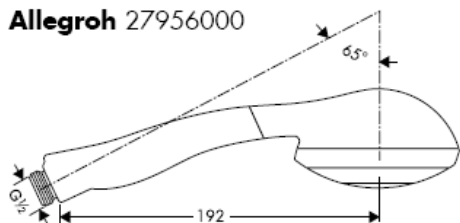

Normal spray



Soft spray

Uno² 27986XXX

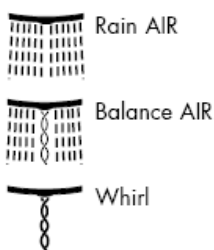
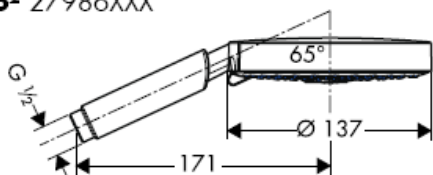

With filter insert (A)

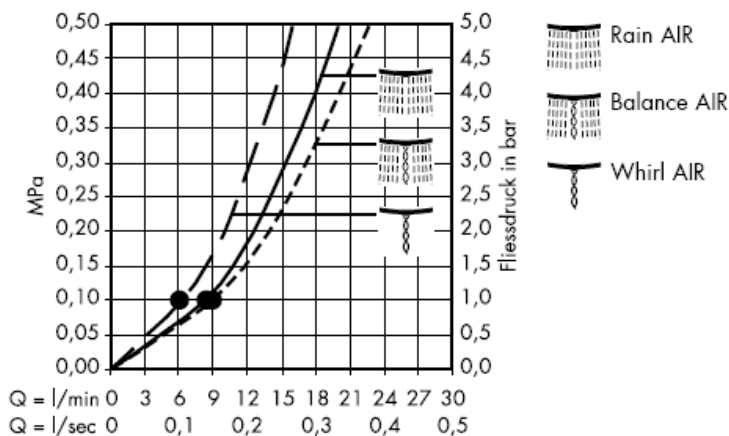

With filter packing (B)

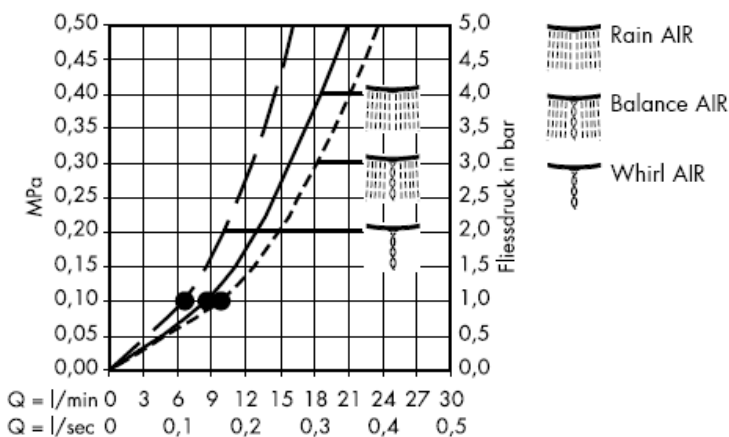

From • the function is guaranteed.

Adjust the dimensions to the tile pattern if required.

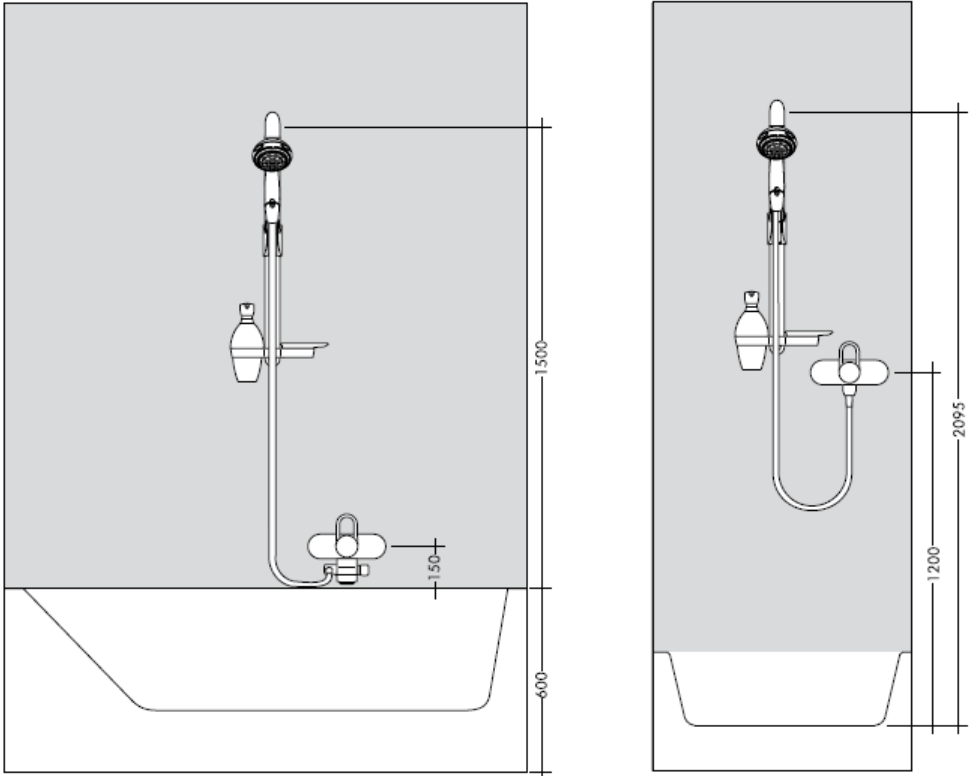

Where the contractor mounts the product, he should ensure that the entire area of the wall to which the mounting plate is to be fitted, is flat (no projecting joints or tiles sticking out), that the structure of the wall is suitable for the installation of the product and has no weak points.

The enclosed screws and dowels are only suitable for concrete. For another wall constructions the manufacturer's indications of the dowel manufacturer have to be taken into account.

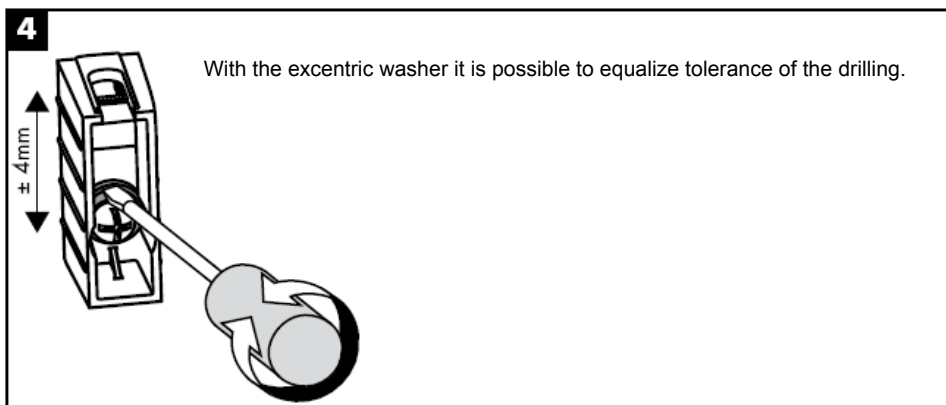
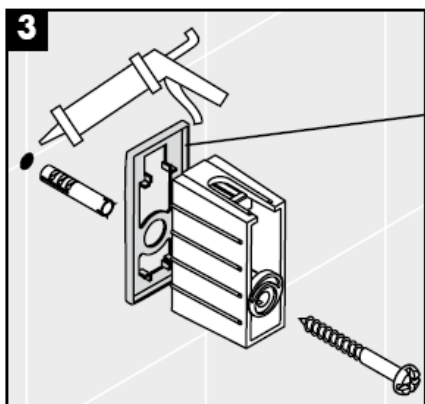
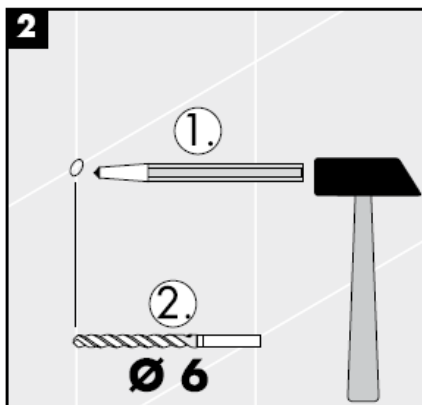
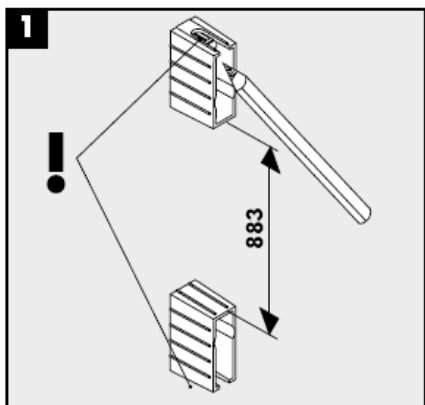

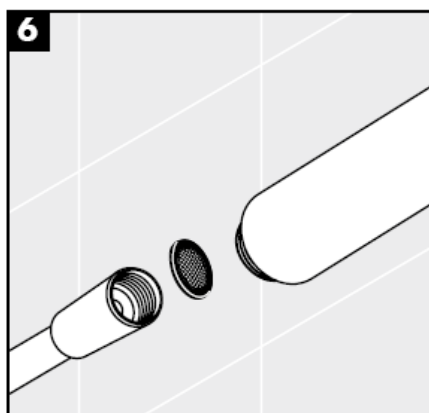
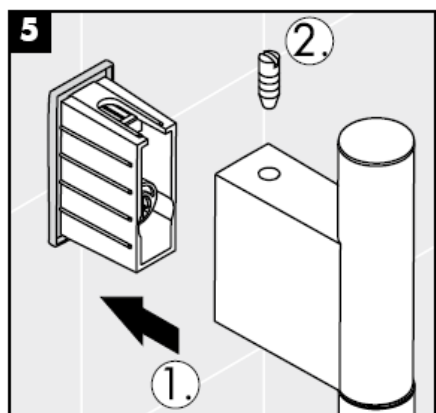

The mesh washer must be insert to protect the overhead shower against incoming dirt by pipework. Incoming dirt leads to defects or/and can damage parts of the shower; such caused faults voids all liability and guarantee claims.

The filter insert (A) must be used to ensure the standard flow rate and to protect the hand shower against incoming dirt by pipework. Do you want a larger water flow rate, then you must use the filter packing (B) instead of the filter insert (A).

Incoming dirt leads to defects or/and can damage parts of the hand shower; such caused faults voids all liability and guarantee claims.

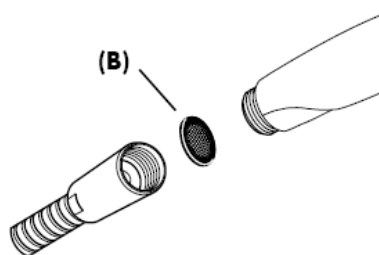
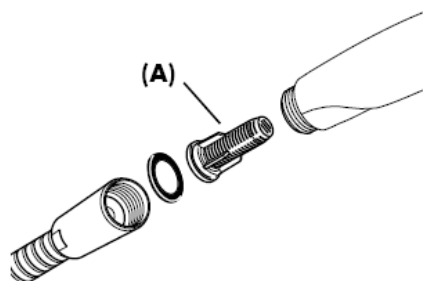

Adjustment

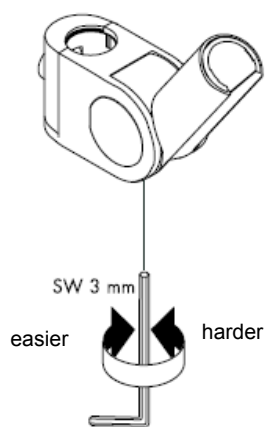
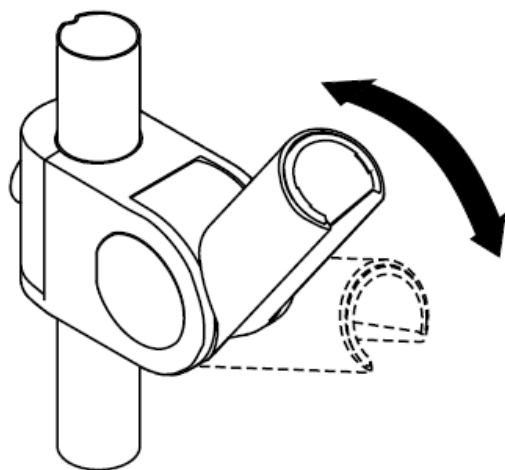
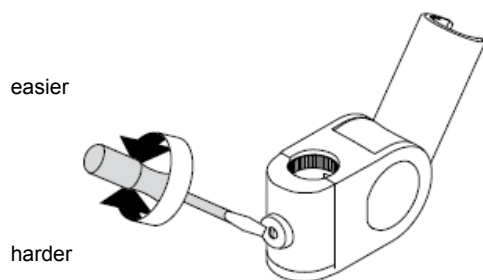
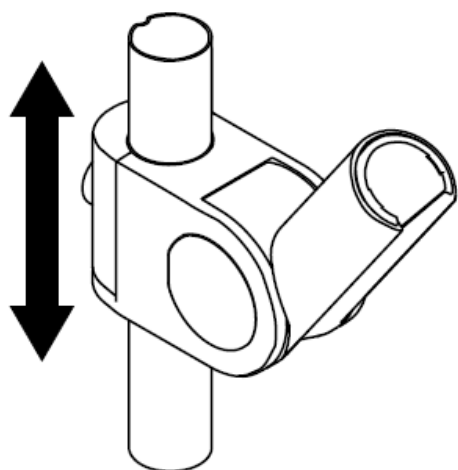

Cleaning

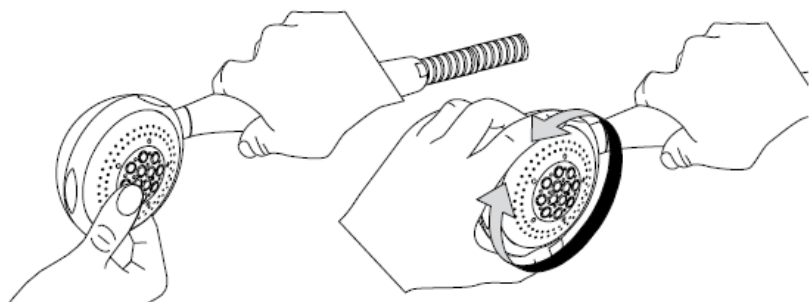

The Rubit® cleaning function only needs a small manual rub over to remove the lime scale from the spray channels.



Cleaning instructions

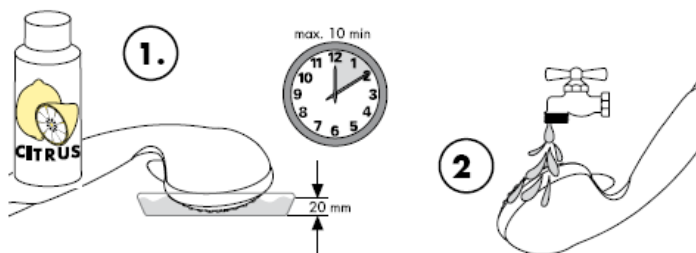

Cleaning

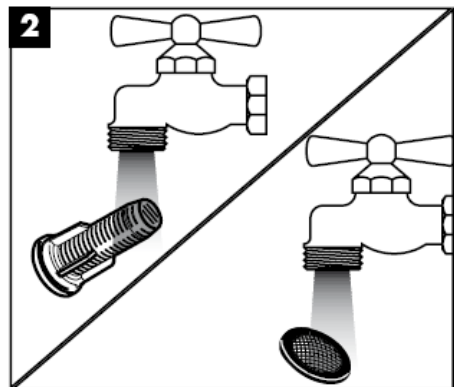
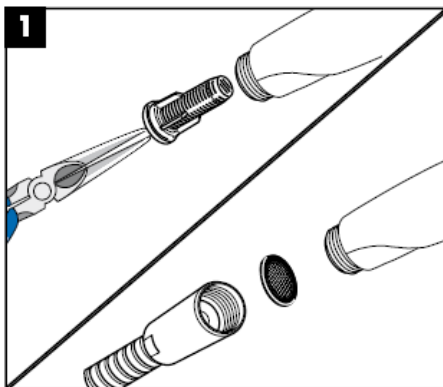
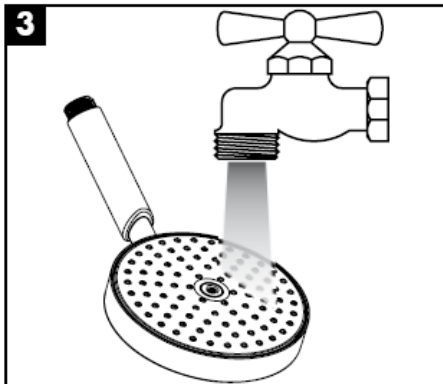
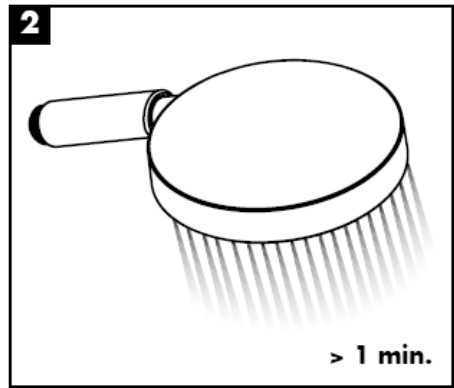
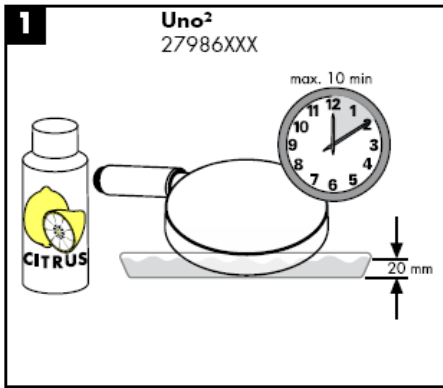

hansgrohe

Istruzioni per Installazione

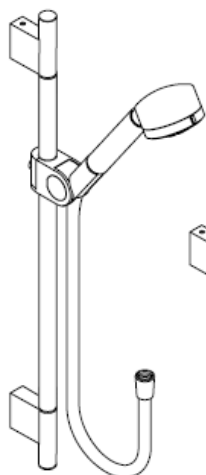

Uno/Arco
27985XXX

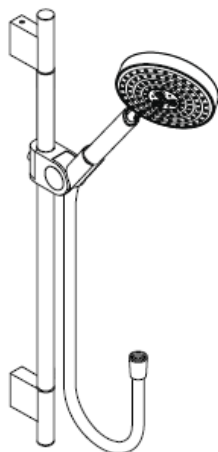

Uno²
27986XXX

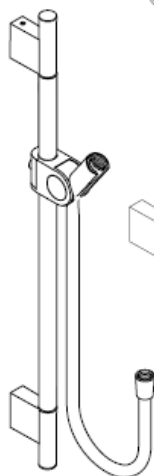

Uno
27989XXX

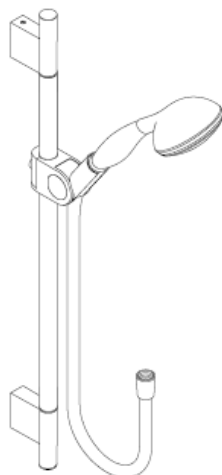

Allegroh
27956000

AXOR®

hansgrohe

Uno/Arco 27985XXX

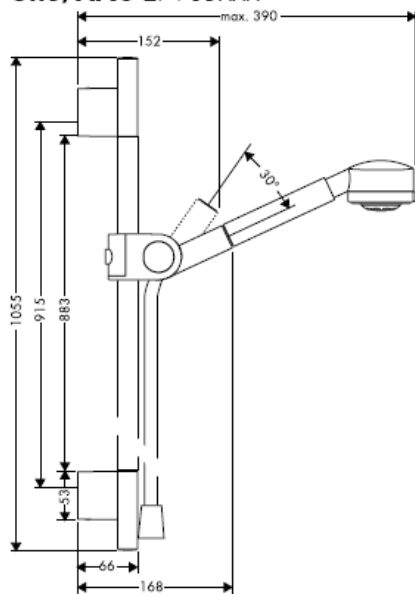

Uno² 27986XXX

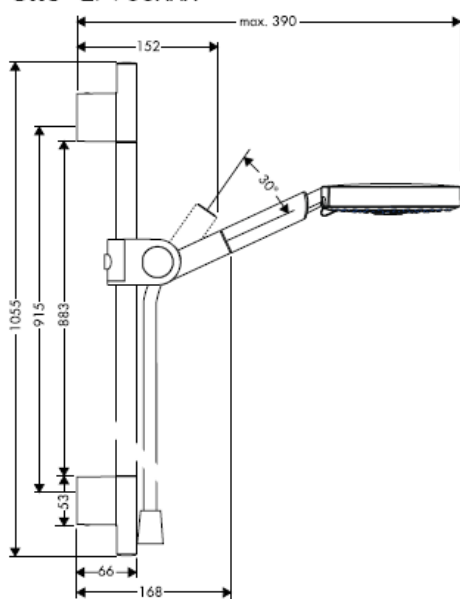

Uno 27989XXX

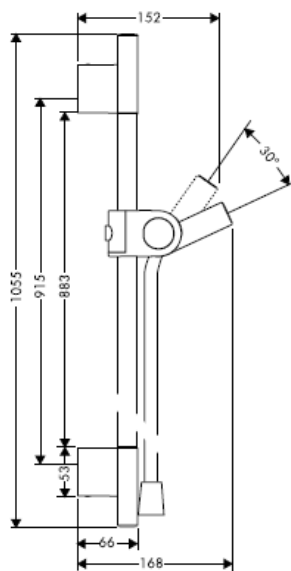

Allegroh 27956000

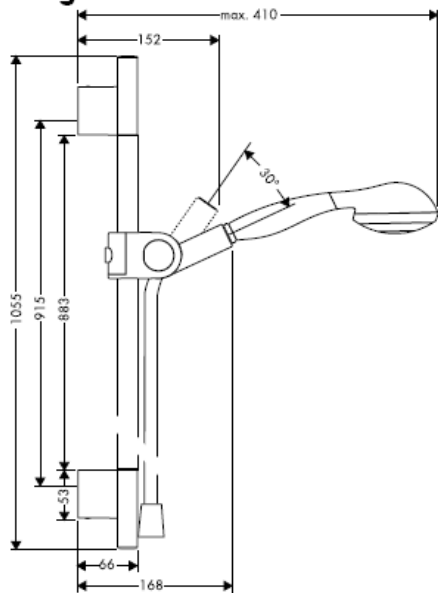



Funzionalità ottimale solamente in combinazione con doccette e flessibili Hansgrohe. I flessibili devono essere inseriti solo tra l'uscita dell'acqua e la doccetta. Non deve essere introdotta alcuna prolunga tra il flessibile e l'uscita dell'acqua.

Dati tecnici

Pressione d'uso: max. 0,6 MPa

Pressione d'uso consigliata: 0,1 – 0,4 MPa
(1 MPa = 10 bar = 147 PSI)

Temperatura dell'acqua calda: max. 60° C

La doccetta è adatta all'uso con caldaie istantanee da 21 kW con portata minima die 7 l/min.

Uno/Arco 27985XXX

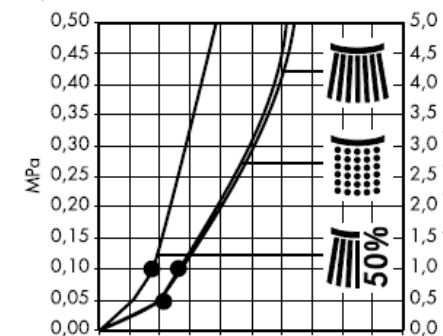
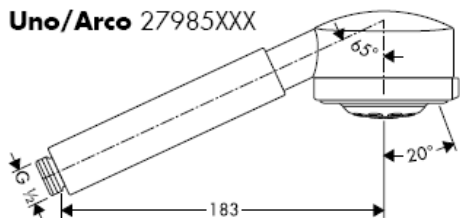

Getto normale a pioggia



Getto areato



Getto eco

Allegroh 27956000

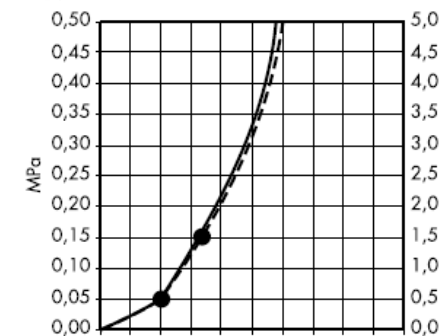
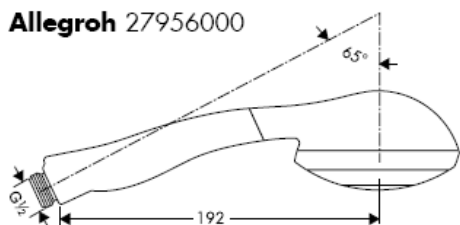

Getto normale a pioggia



Getto areato

Uno² 27986XXX

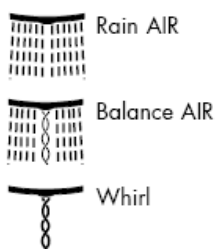
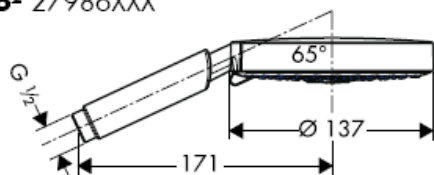

Con filtro supplementare (A)

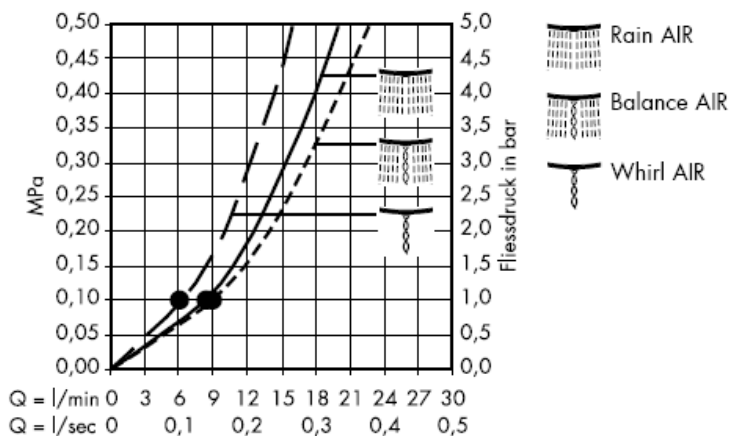

Con filtro di imballaggio

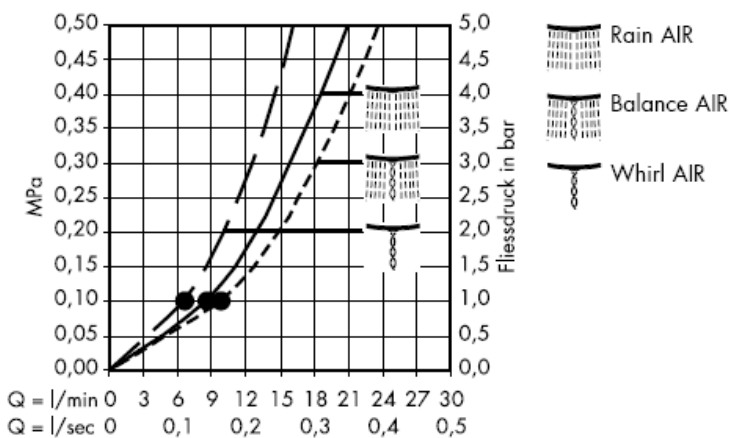

Dal • si garantisce la funzionalità.

Adattare le misure alla dimensione delle piastrelle.

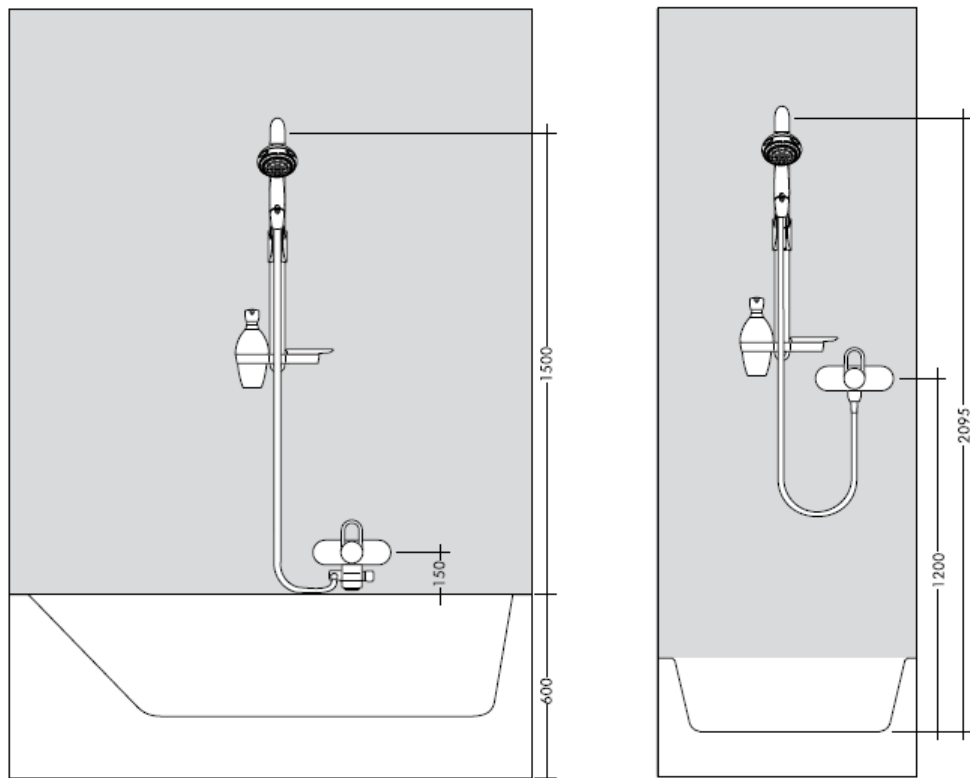

Quando il personale tecnico specializzato esegue il montaggio del prodotto è necessario assicurarsi che la superficie di fissaggio sia piana in tutta l'area di fissaggio (senza giunti sporgenti o spostamento delle piastrelle), che la struttura della parete sia adatta per il montaggio del prodotto e soprattutto che non ci siano dei punti deboli.

Le viti e i tasselli in dotazione sono adatti solo per calcestruzzo. In caso di altre strutture della parete vanno osservare le indicazioni del produttore dei tasselli.

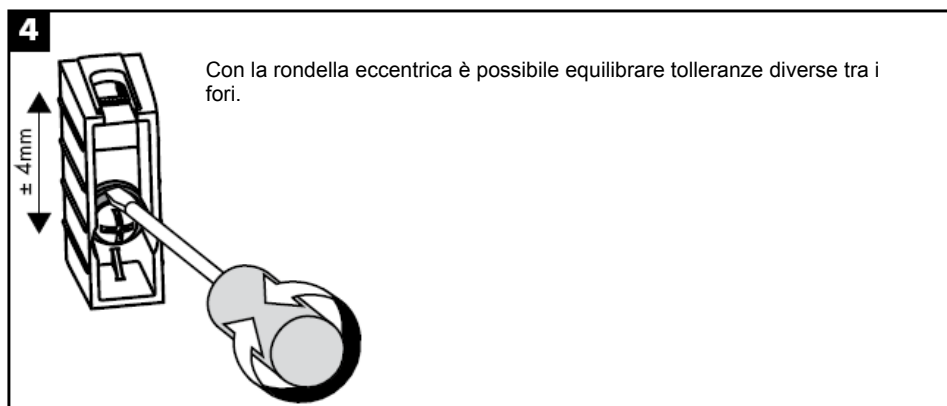
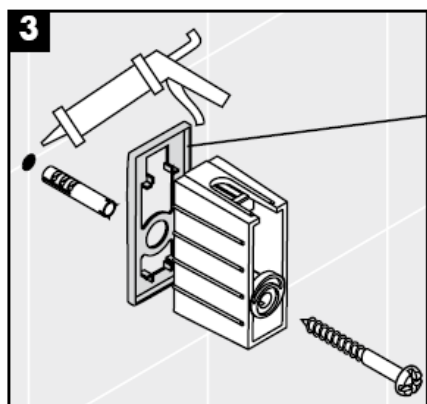
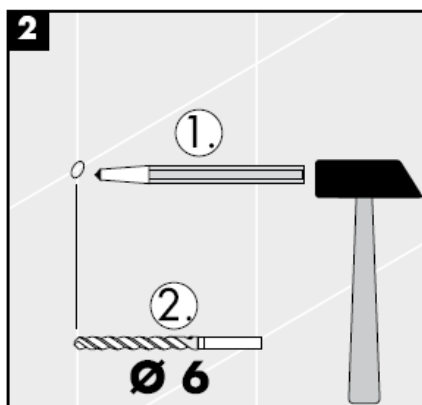
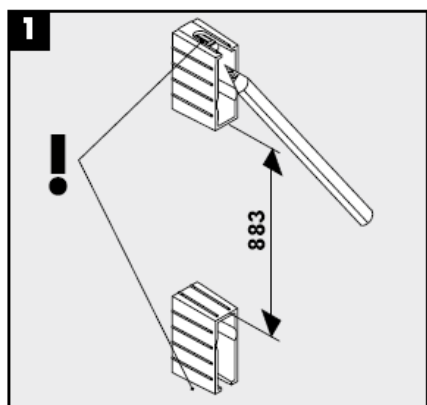

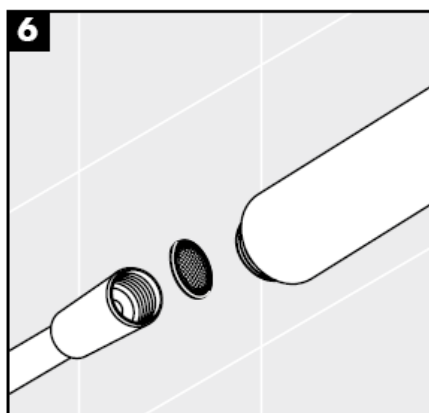
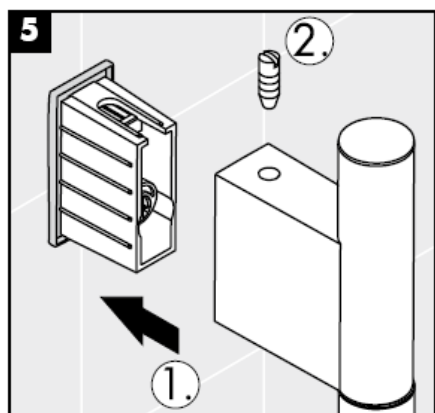

Per proteggere la soffione doccia da eventuali impurità provenienti dalle tubazioni dell'acqua, deve essere inserito il filtro nell'impugnatura della doccia stessa. Tali impurità possono infatti causare difetti e/o danneggiare parti della doccia; in questo caso la Hansgrohe non risponde dei danni.

Il filtro supplementare (A) deve essere utilizzato per assicurare il normale flusso dell'acqua e proteggere la doccetta dai depositi di calcare.

Se volete un flusso d'acqua maggiore dovete usare il filtro dell'imballaggio(B) invece del filtro supplementare(A).

Lo sporco in entrata può danneggiare le parti della doccetta; questo é motivo di molte lamentele del cliente.

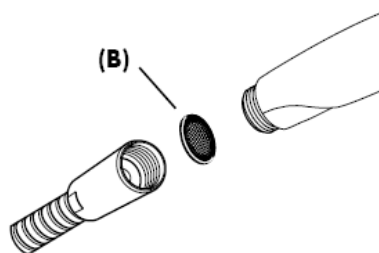
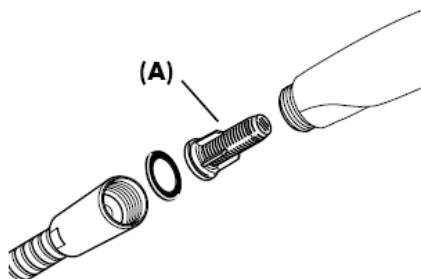

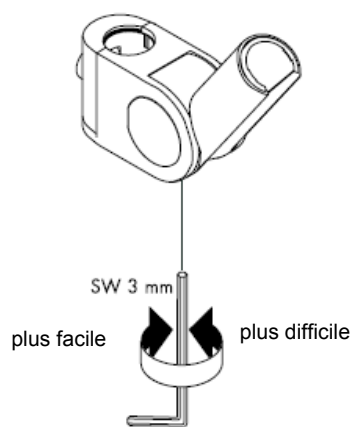
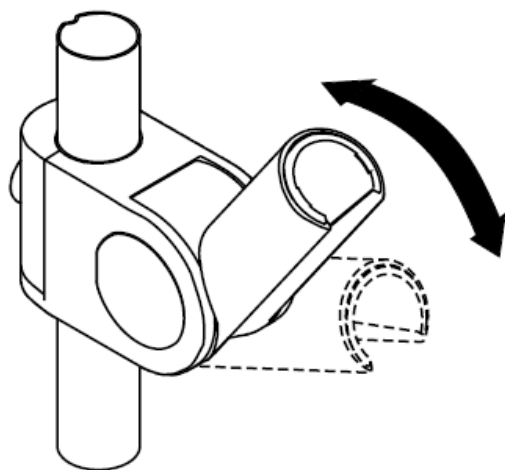
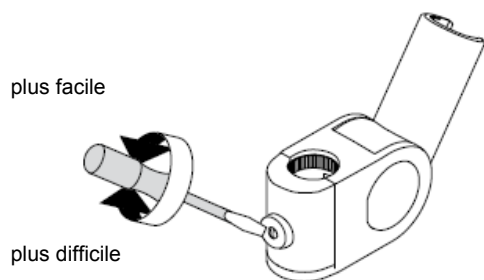
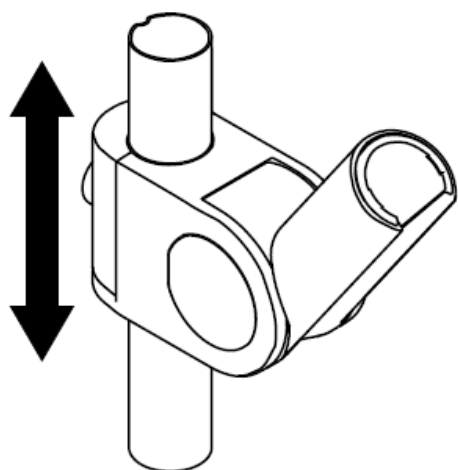

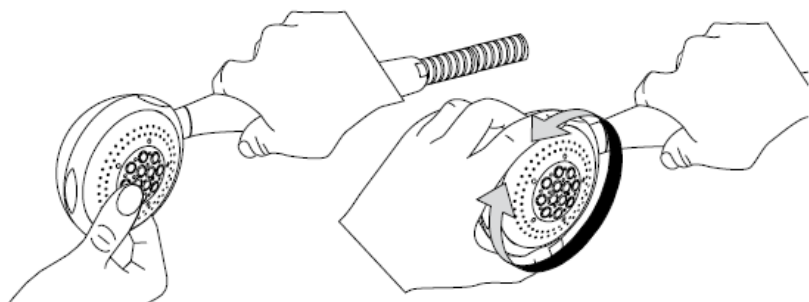

Con Rubit®, la funzione anticalcare manuale, i diffusori del getto possono essere liberati da calcare con un semplice strofinamento.



Istruzioni per il trattamento

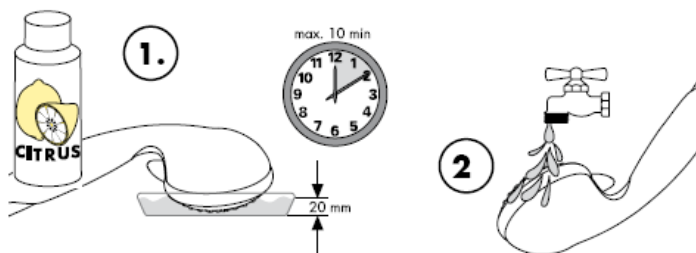

Pulitura

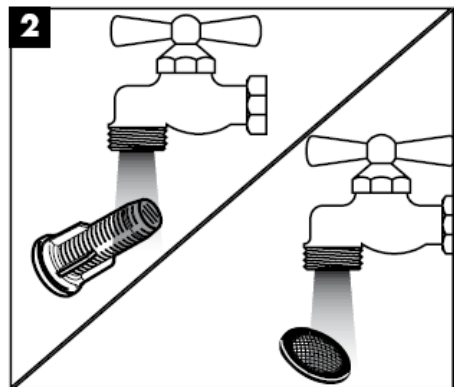
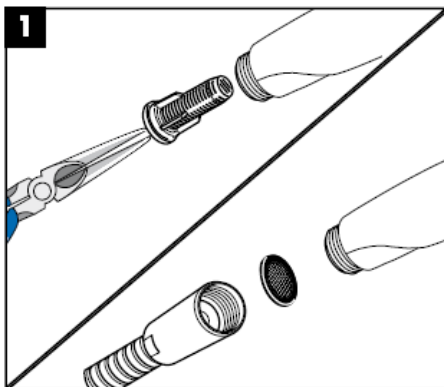
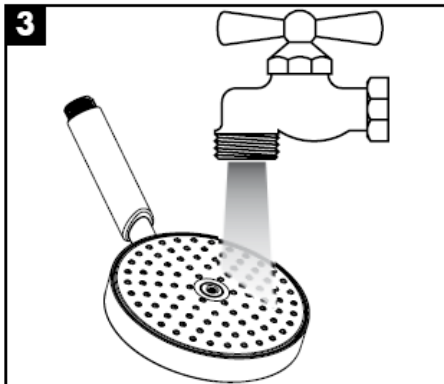
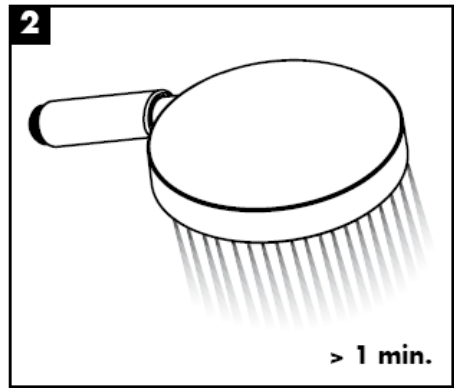
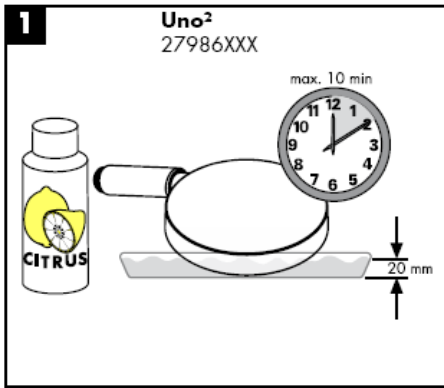

hansgrohe

Instrucciones de montaje

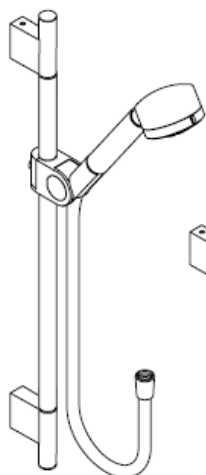

Uno/Arco
27985XXX

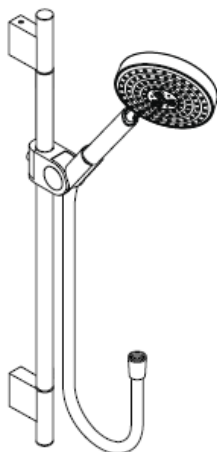

Uno²
27986XXX

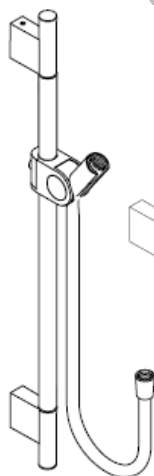

Uno
27989XXX

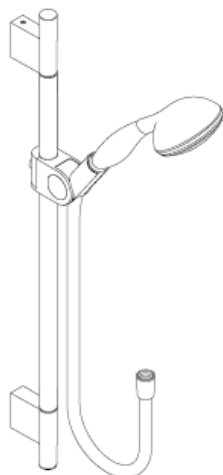

Allegroh
27956000

AXOR®

hansgrohe

Uno/Arco 27985XXX

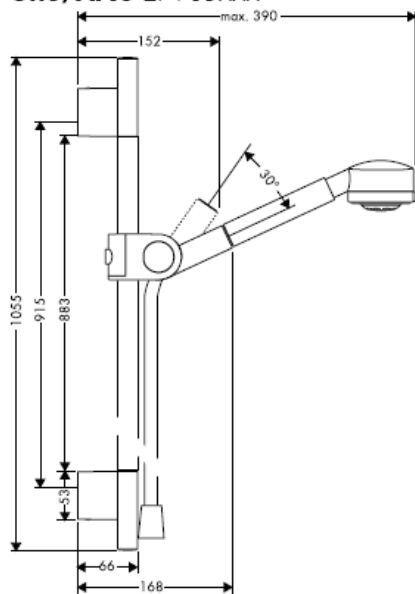

Uno² 27986XXX

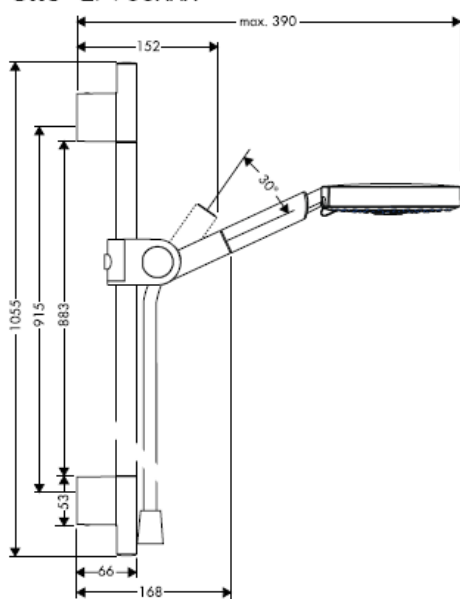

Uno 27989XXX

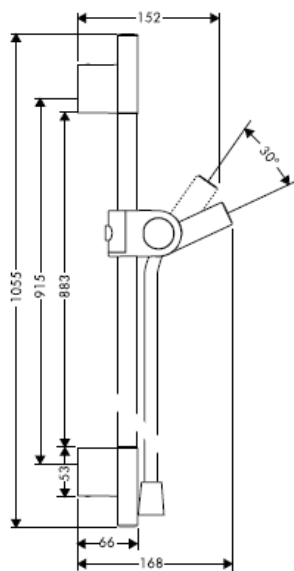

Allegroh 27956000

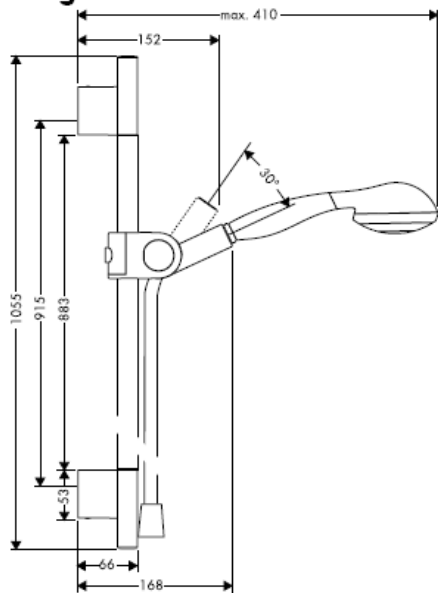



Sólo se garantiza una función óptima en combinación con teleduchas y flexos de Hansgrohe. Los flexos deben usarse exclusivamente para la conexión entre grifería y teleducha. Cualquier función de cierre tras el flexo y en la dirección del flujo del agua no está permitida.

Datos técnicos

Presión en servicio: max. 0,6 MPa
Presión recomendada en servicio: 0,1 – 0,4 MPa
(1 MPa = 10 bar = 147 PSI)
Temperatura del agua caliente: max. 60° C

La teleducha se puede instalar con un calentador continuo de 21 kW de potencia o superior y un caudal mínimo de 7 l/min.

Uno/Arco 27985XXX

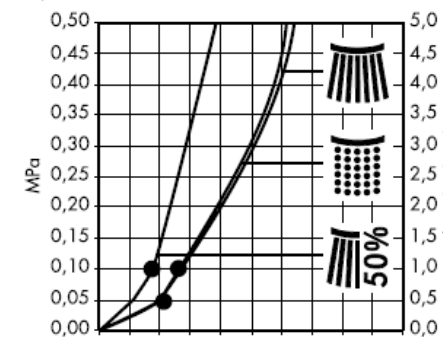
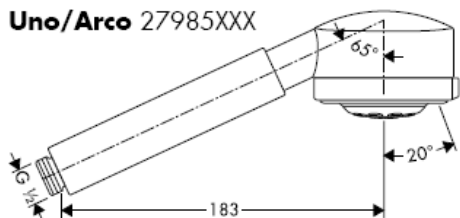

Chorro de lluvia



Chorro espumoso



Chorro eco

Allegroh 27956000

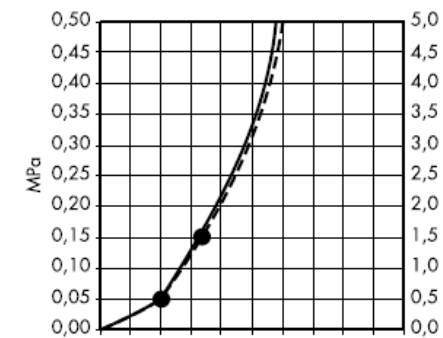
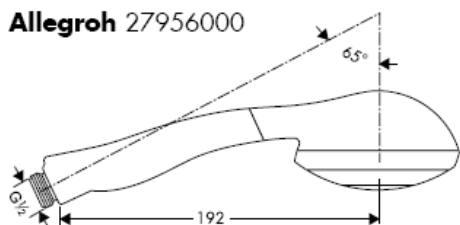

Chorro de lluvia



Chorro espumoso

Uno² 27986XXX

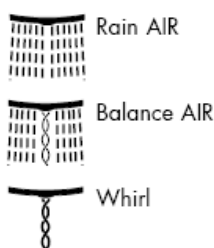
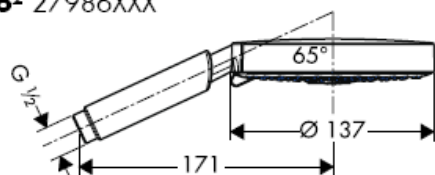

Con inserción de filtro (A)

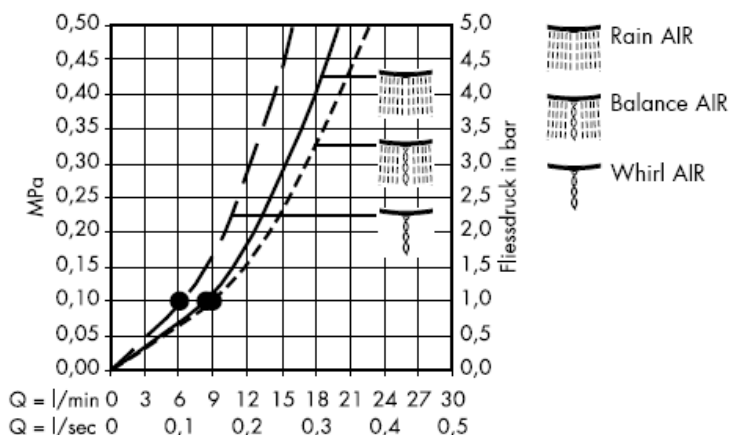

Con paquete de filtro (B)

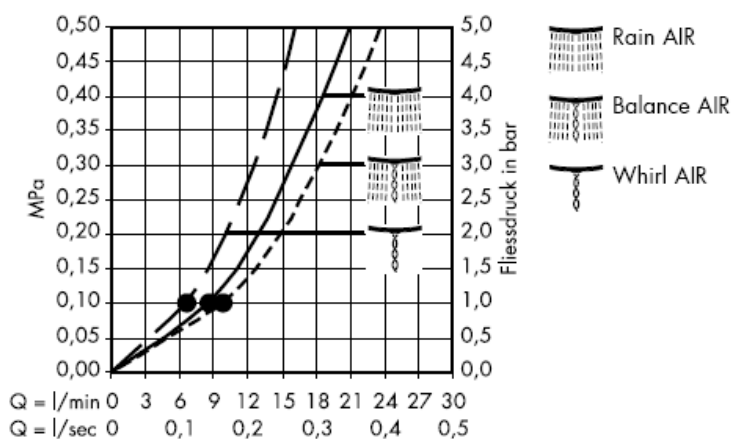

Mínimo • para el correcto funcionamiento.

Adaptar las medidas al retículo de los azulejos.

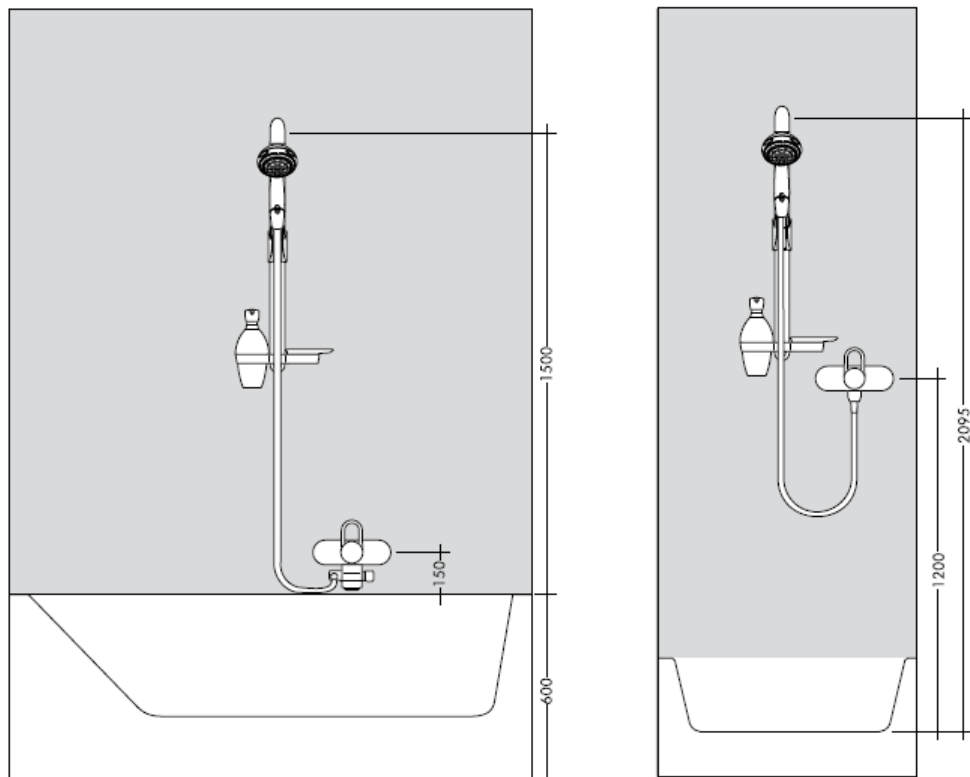

En el momento del montaje del producto por parte de personal especializado y cualificado se deberá prestar una atención especial a que la superficie de fijación en toda el área de la fijación sea plana (sin juntas que sobresalen ni azulejos desplazados), que la estructura de la pared sea adecuada para un montaje del producto y que, ante todo, no presente puntos débiles.

Los tornillos y tacos adjuntos son sólo apropiados para hormigón. En el caso de otras estructuras murales se deberán considerar las indicaciones del fabricante de tacos.

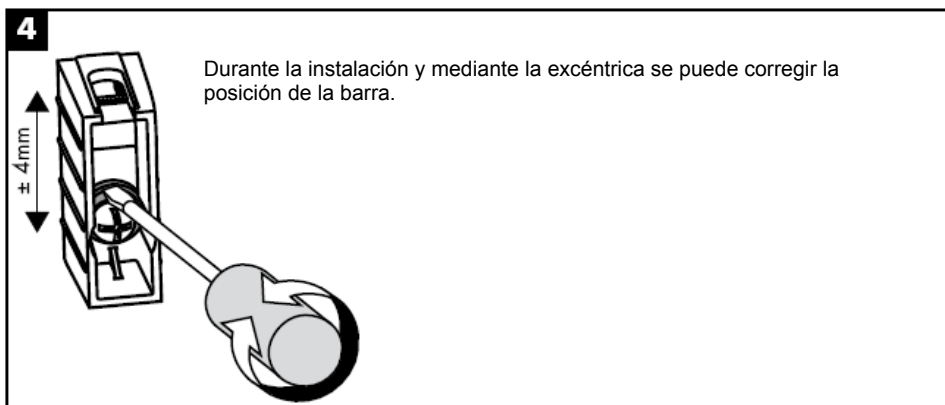
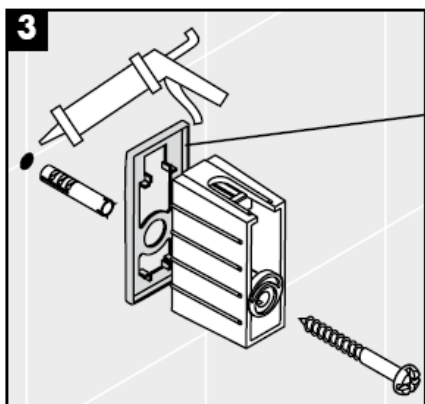
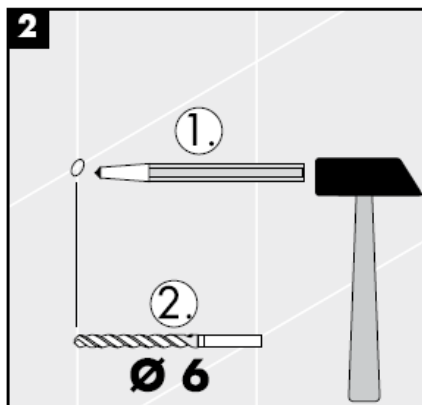
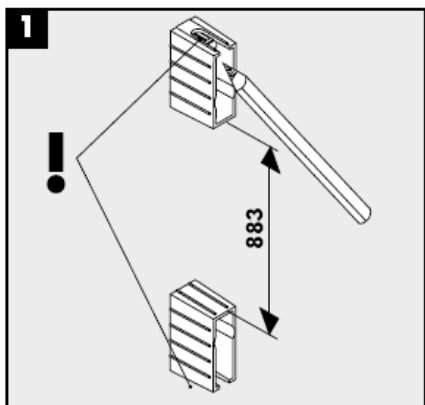

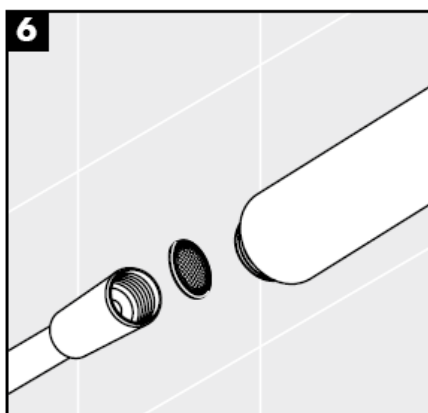
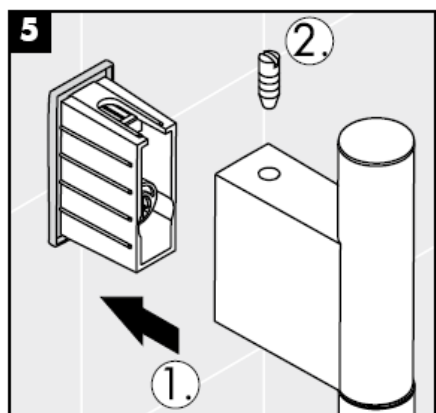

La junta de filtración que se suministra con la ducha mural evita que las partículas de suciedad procedentes de las tuberías lleguen a la ducha mural. Debe colocarse entre el flexo y la ducha mural. Infiltraciones de suciedad deterioran el funcionamiento de la ducha mural y pueden causar daños en el interior de la misma que no están cubiertas por la garantía de Hansgrohe.

La inserción del filtro (A) debe usarse para asegurar el caudal estandar y para proteger la ducha de la suciedad proveniente de las tuberías. Si se quiere un caudal mayor, se debe usar el paquete de filtro (B) en lugar de la inserción de filtro (A).

La suciedad puede producir defectos y/o puede dañar partes de la cabecera de la ducha. Por dichos defectos o fallos Hansgrohe no se hace responsable.

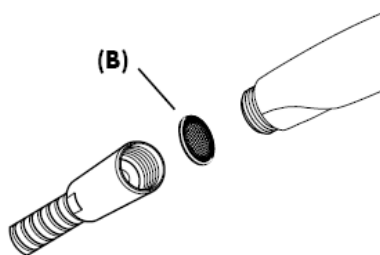
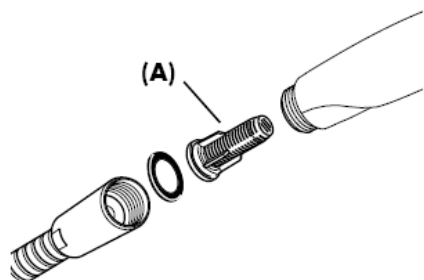

Puesta a punto

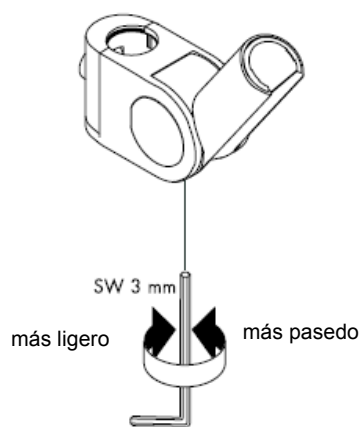
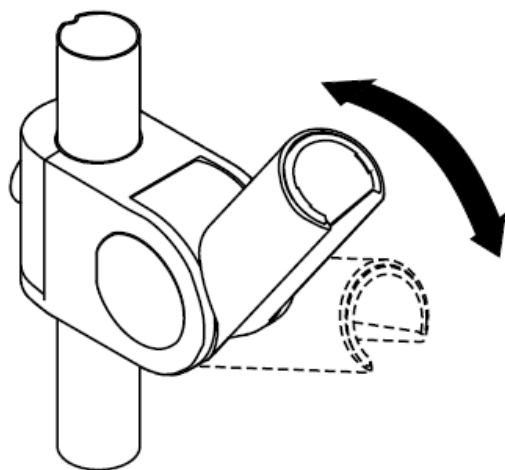
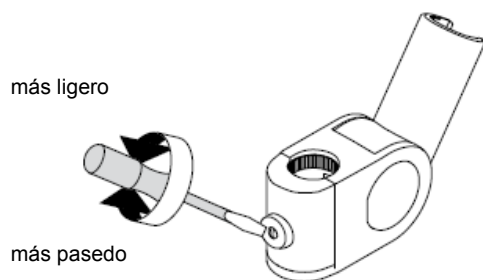
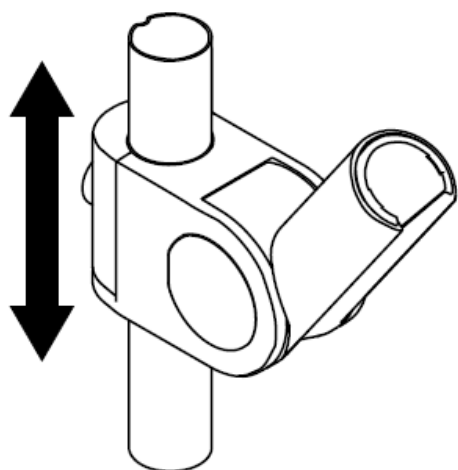

Limpiar

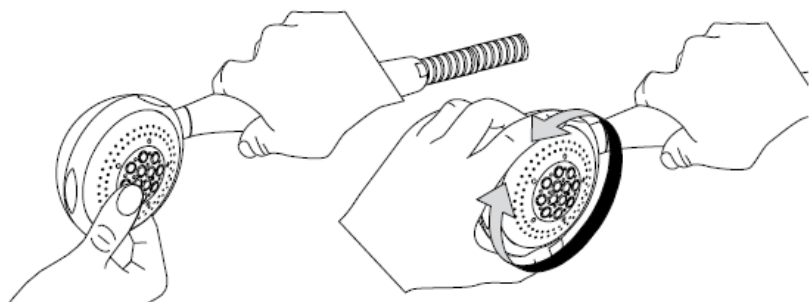

Rubit®, la función de limpieza manual, permite quitar la cal simplemente frotando los ejectores.



Entretimiento

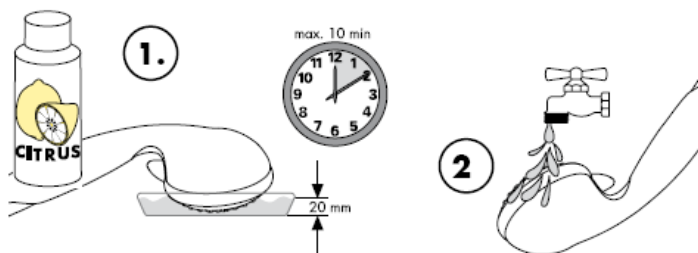

Limpiar

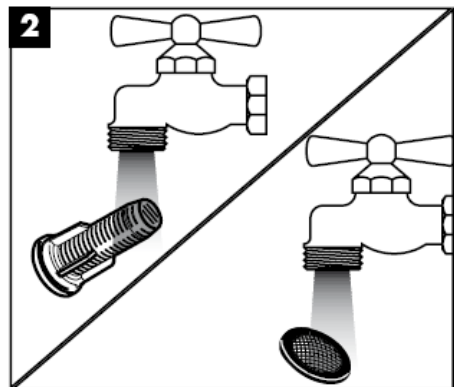
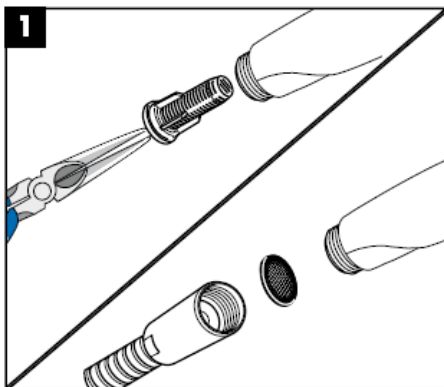
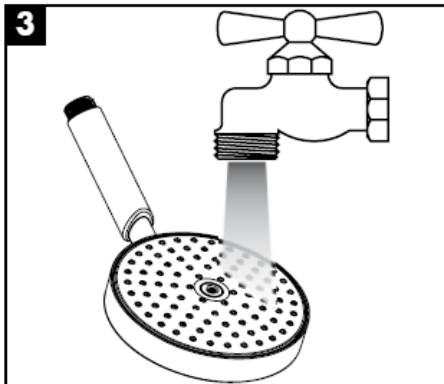
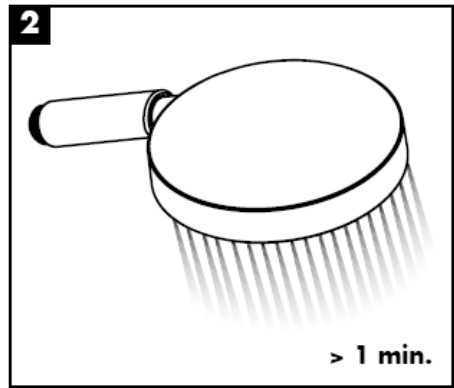
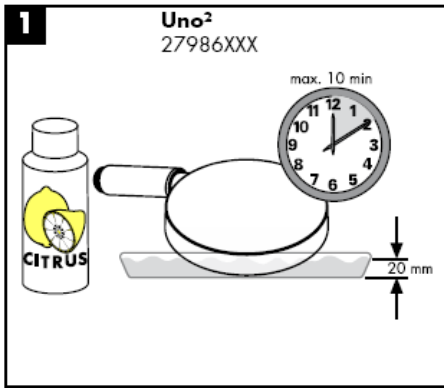

hansgrohe

Handleiding

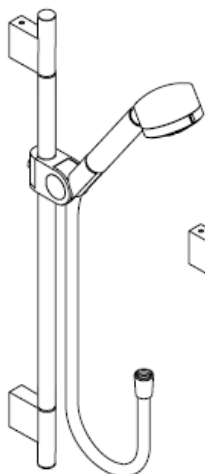

Uno/Arco
27985XXX

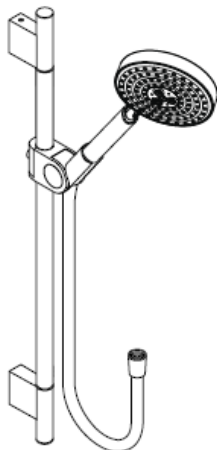

Uno²
27986XXX

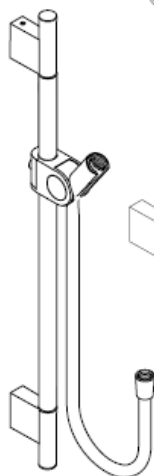

Uno
27989XXX

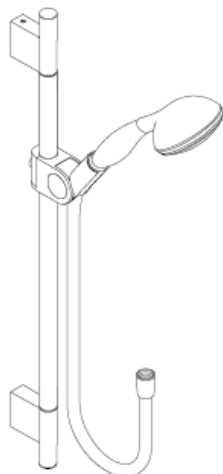

Allegroh
27956000

AXOR[®]

hansgrohe

Uno/Arco 27985XXX

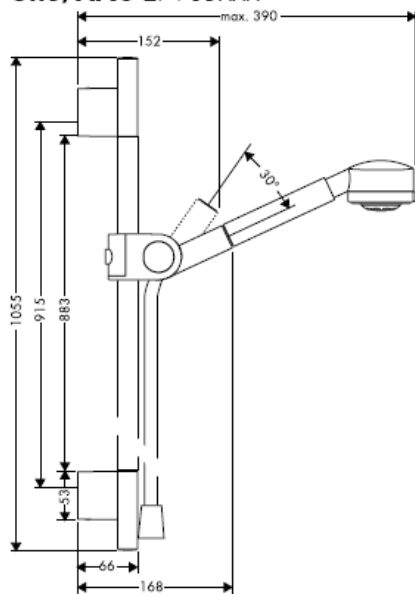

Uno² 27986XXX

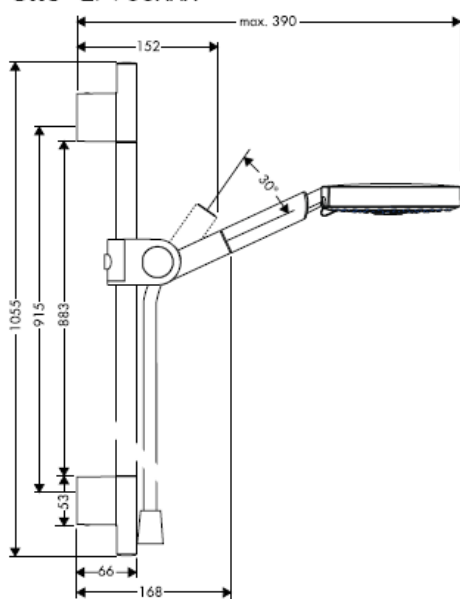

Uno 27989XXX

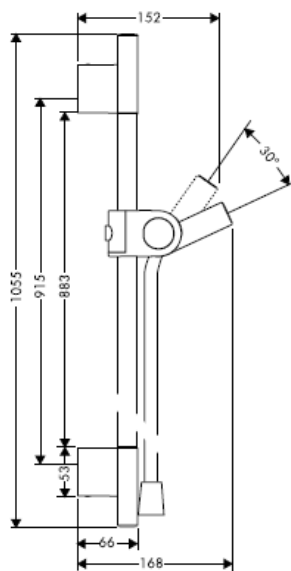

Allegroh 27956000

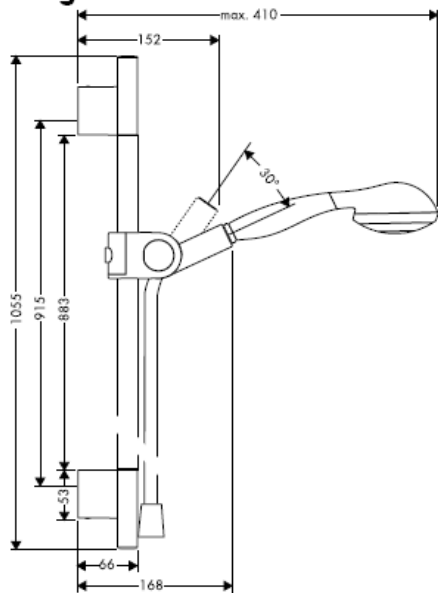



Optimal functioneren gegarandeerd bij combinatie met Hansgrohe handdouche en doucheslang. De doucheslangen zijn alleen geschikt voor de aansluiting van douches aan kranen. Een versperring ná de doucheslang in de stroomrichting is niet toelaatbaar.

Technische gegevens

Werkdruk: max.	max. 0,6 MPa
Aanbevolen werkdruk: (1 MPa = 10 bar = 147 PSI)	0,1 – 0,4 MPa
Temperatuur warm water:	max. 60° C

De handdouche is geschikt voor gebruik bij doorstroomtoestellen vanaf 21 kW met een minimale doorstroom van 7 l/min.

Uno/Arco 27985XXX

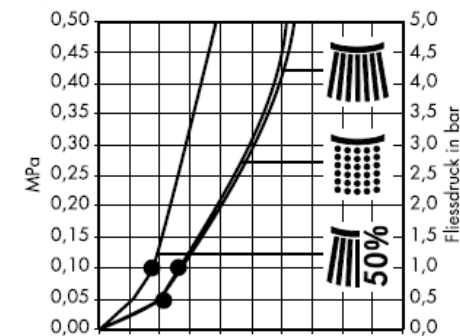
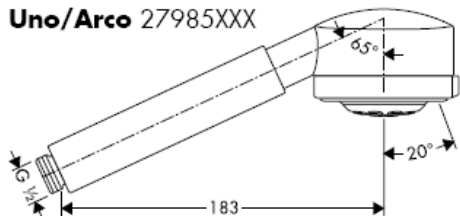

Normale douchestraal



Softstraal



Ecostraal

Allegroh 27956000

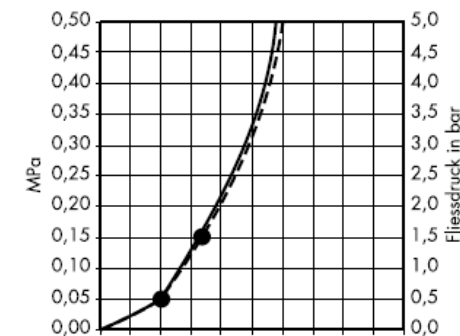
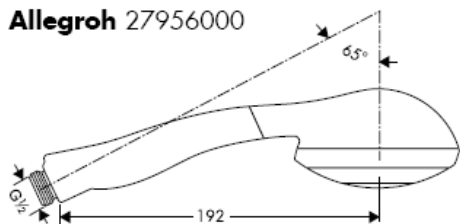

Normale douchestraal



Softstraal

Uno² 27986XXX

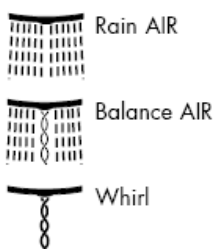
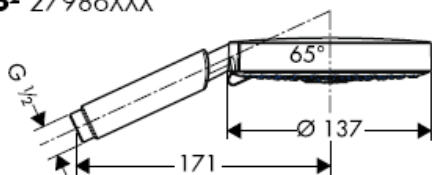

Met filter (A)

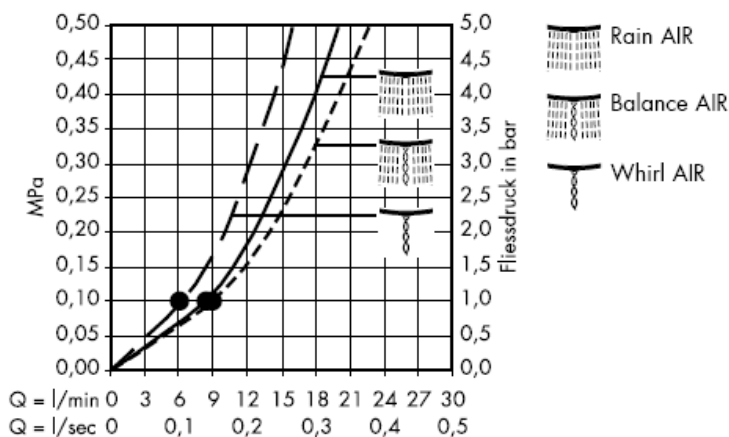

Met dichting (B)

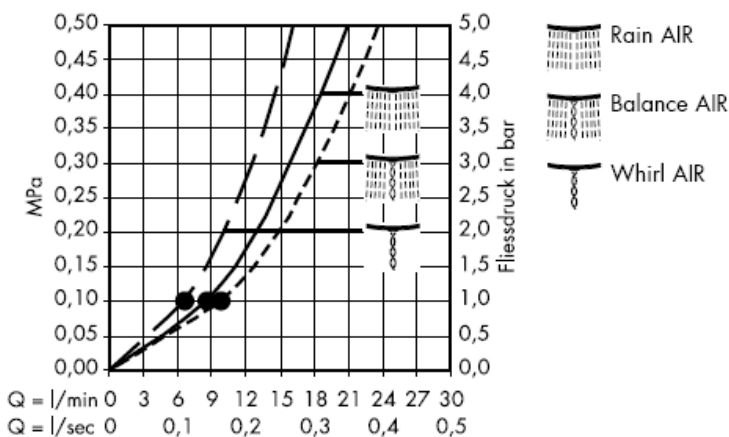

Vanaf • is het functioneren gegarandeerd.

Maten indien mogelijk aan het tegelwerk aanpassen.

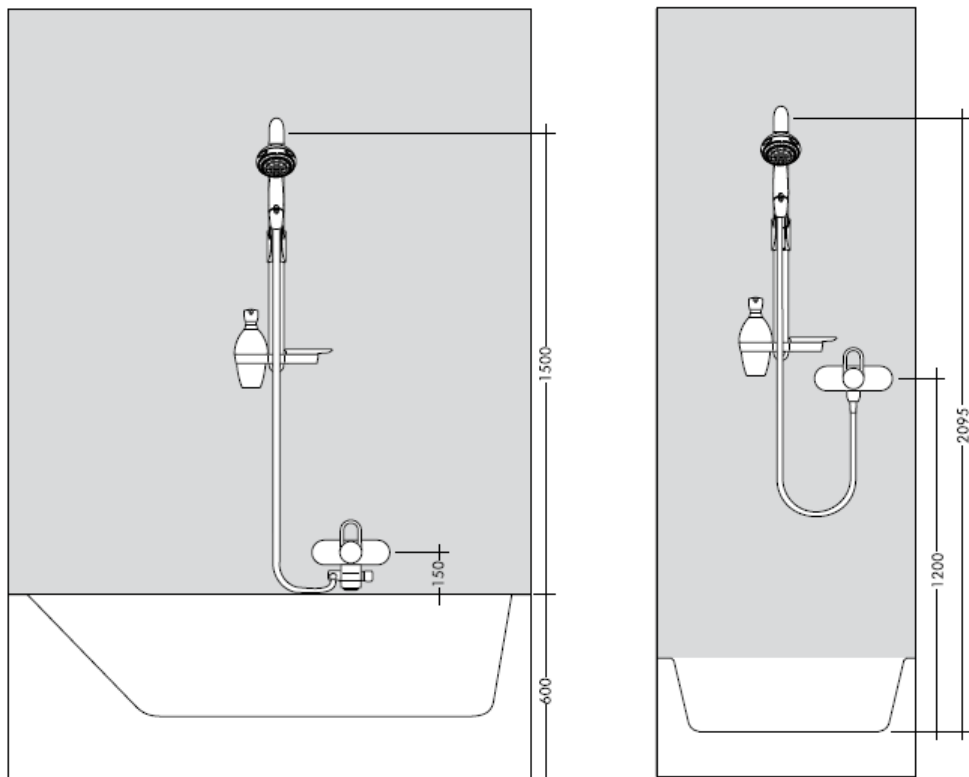

Bij de montage van het produkt door een vakkundige installateur moet men erop letten dat het bevestigingsoppervlak op één oppervlak zit (dus geen opliggende voegen of verspringende tegels), de wand geschikt is voor montage van produkten en zeker geen zwakke plekken bevat. De bijgevoegde schroeven en duvels zijn alleen geschikt voor beton. Bei andere wandsoorten dient u te letten op de voorschriften van de fabrikant van de schroeven en duvels.

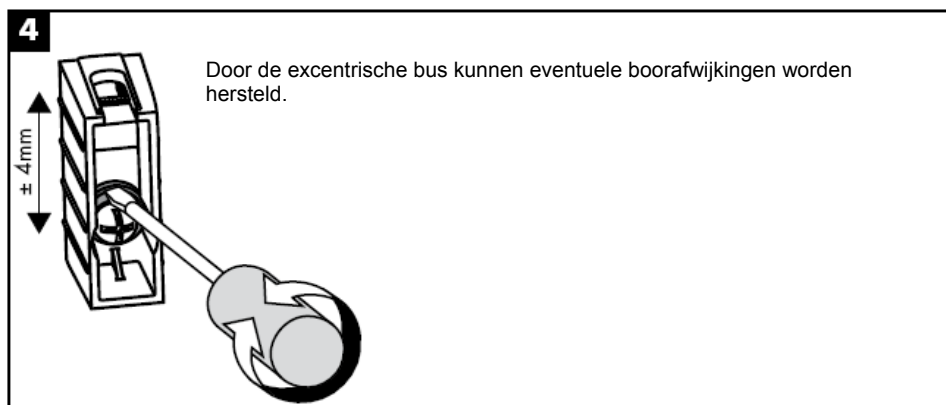
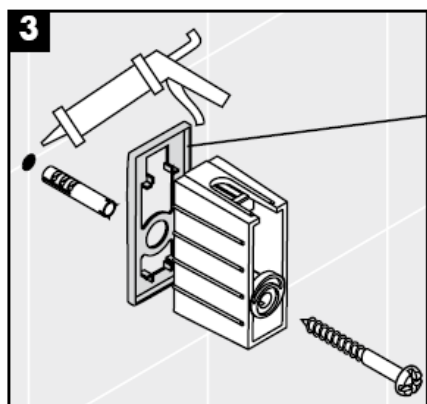
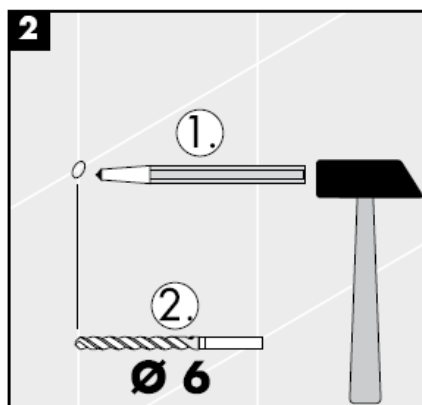
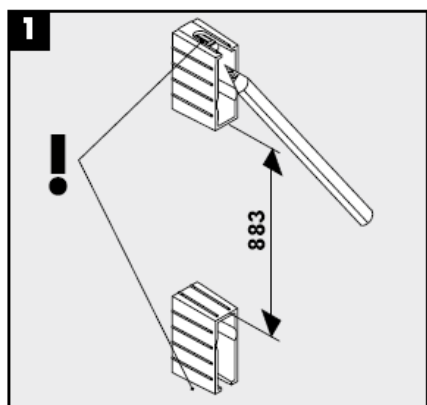

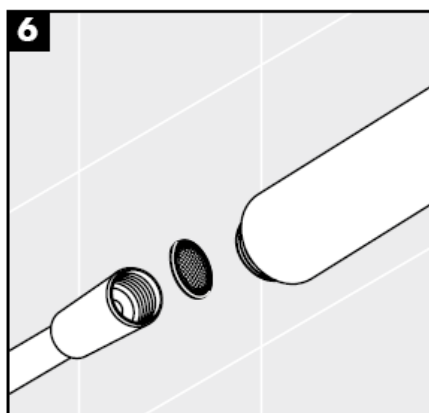
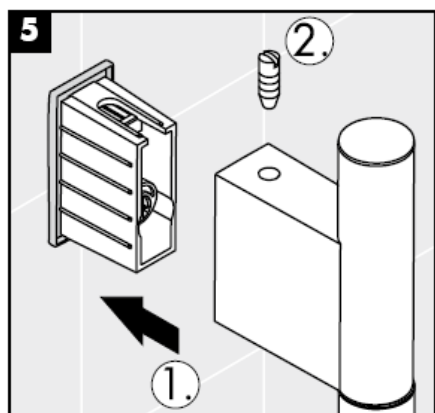

Het bij de hoofddouche verpakte zeefje moet worden ingebouwd om vuil uit de waterleiding te weren. Vuil uit de leidingen kan de werking van de hoofddouche negatief beïnvloeden en/of de hoofddouche beschadigen. Voor deze schade is Hansgrohe niet verantwoordelijk.

De bijgeleverde filter (A) moet ingebouwd worden om de norm doorstroom van de handdouche te garanderen en vuil uit de leidingen tegen te houden. Als er een grotere waterdoorlaat gewenst wordt moet i.p.v. het filter de dichting geplaatst worden. Vuil uit de leidingen kan schade aan de handdouche veroorzaken. Op deze schade geeft Hansgrohe geen garantie.

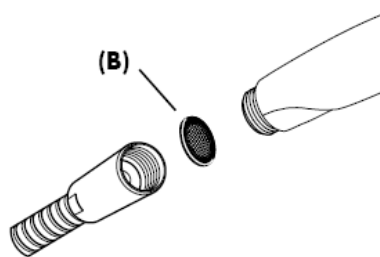
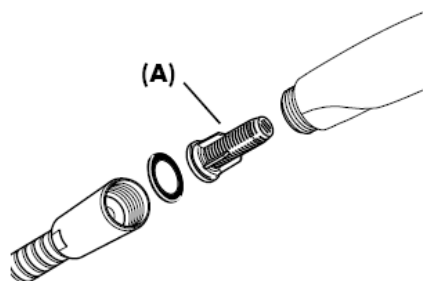

Correctie

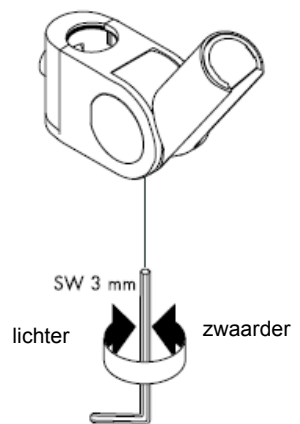
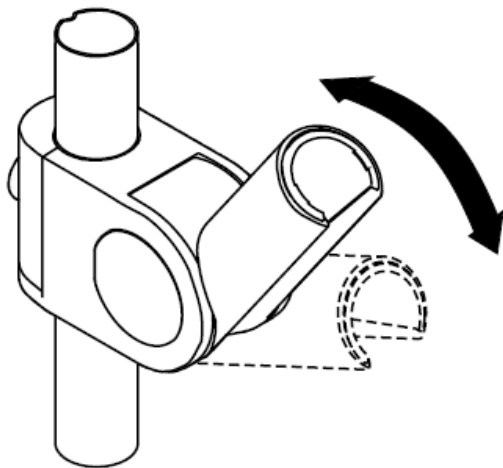
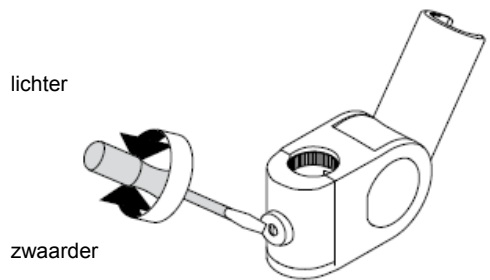
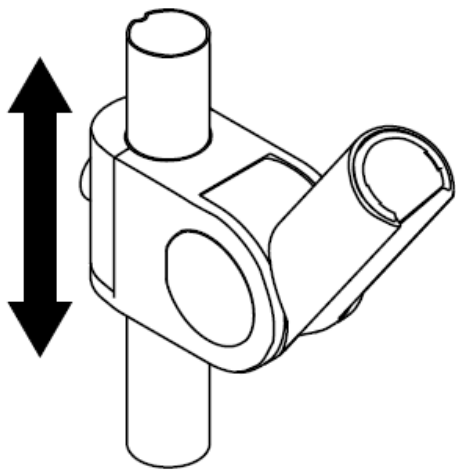

Reinigen

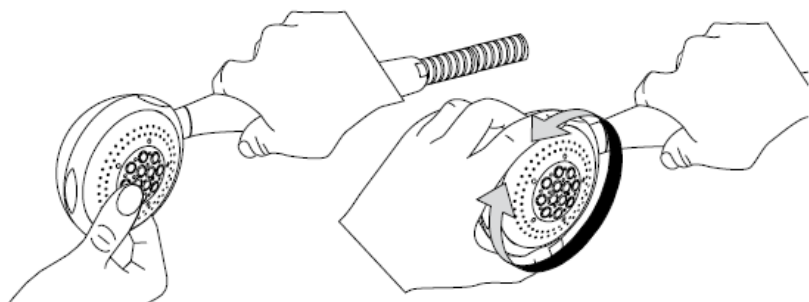

Met Rubit®, de handmatige reinigingsfunctie, kunnen de straalopeningen door het met de hand wegwrijven van kalk, gereinigd worden.

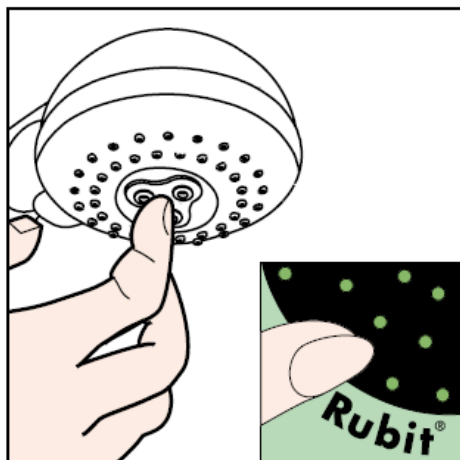

Reinigingsaanwijzingen

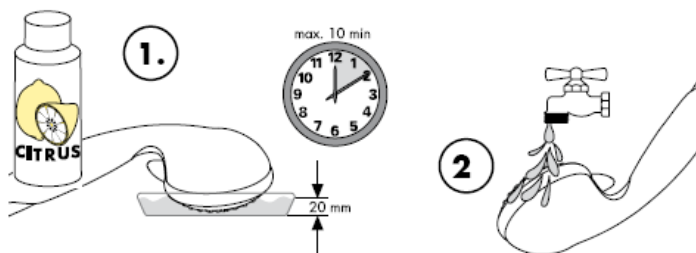

Reinigen

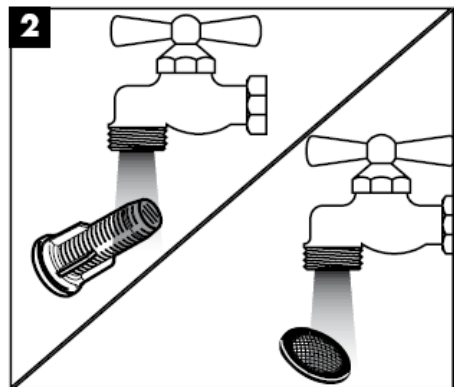
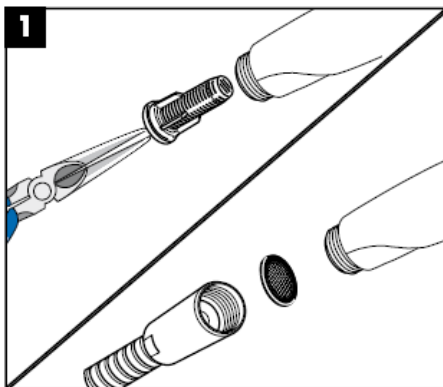
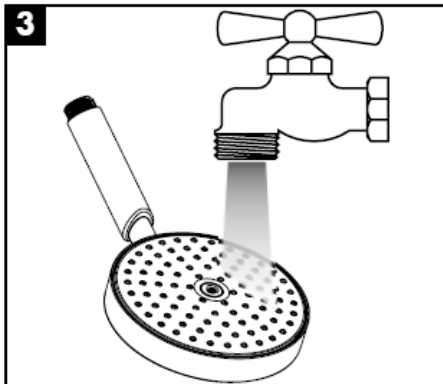
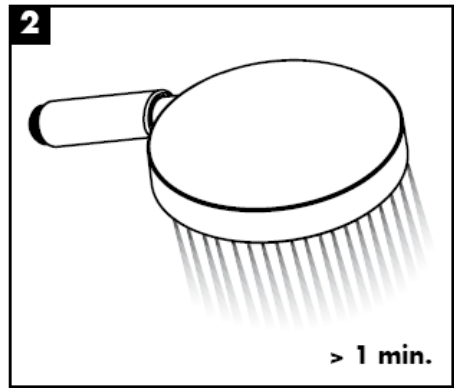
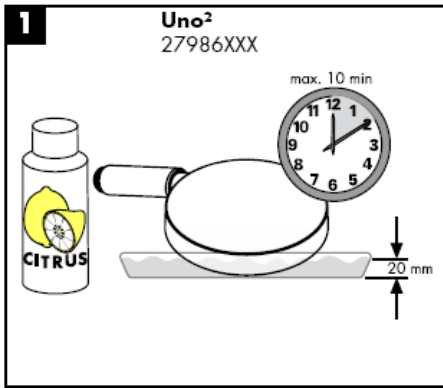

hansgrohe

Monteringsvejledning

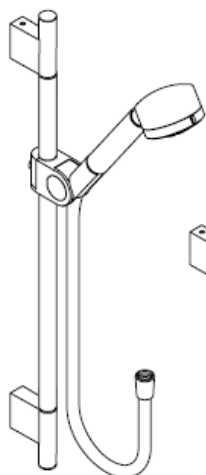

Uno/Arco
27985XXX

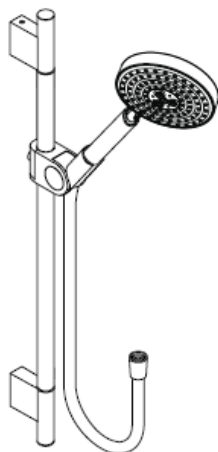

Uno²
27986XXX

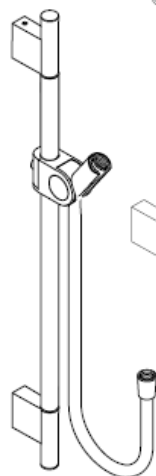

Uno
27989XXX

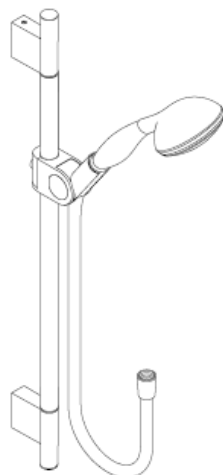

Allegroh
27956000

AXOR®

hansgrohe

Uno/Arco 27985XXX

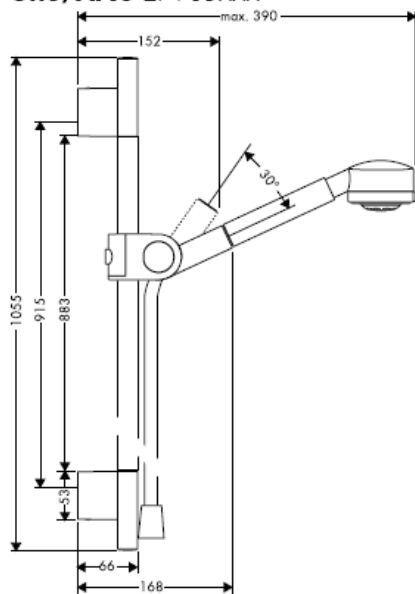

Uno² 27986XXX

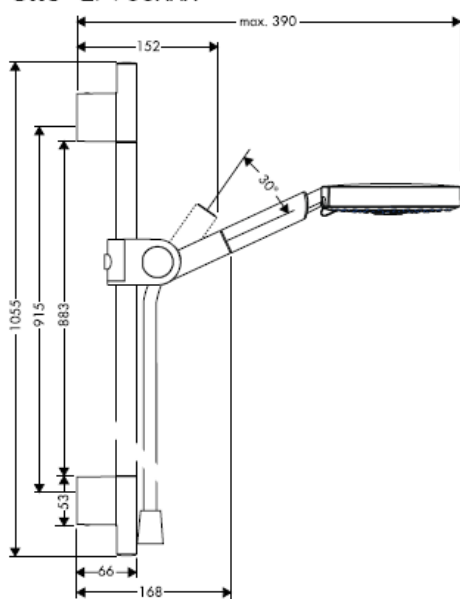

Uno 27989XXX

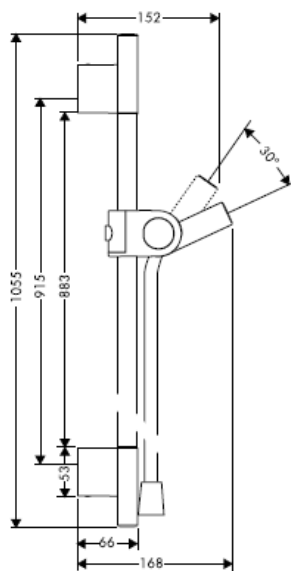

Allegroh 27956000

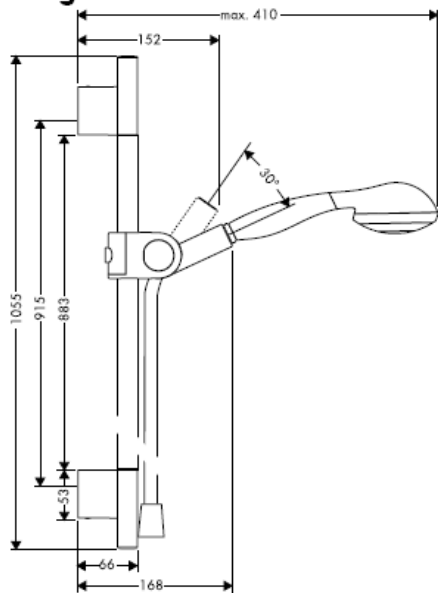



Optimal funktion garanteres for anvendelse i forbindelse med Hansgrohe håndbrusere og Hansgrohe bruseslanger. Bruserslanger bør kun anvendes i forbindelse med tilslutning mellem brusere og armatur. Det er ikke tilladt at montere en afspærringsventil mellem bruser og slange!

Tekniske data

Driftstryk:	max. 0,6 MPa
Anbefalet driftstryk: (1 MPa = 10 bar = 147 PSI)	0,1 – 0,4 MPa
Varmtvandstemperatur:	max. 60° C

Håndbruseren er velegnet i forbindelse med gennemstrømningsvandvarmere på min 21 kW samt en gennemstrømningsmængde på min. 7 l/min.

Uno/Arco 27985XXX

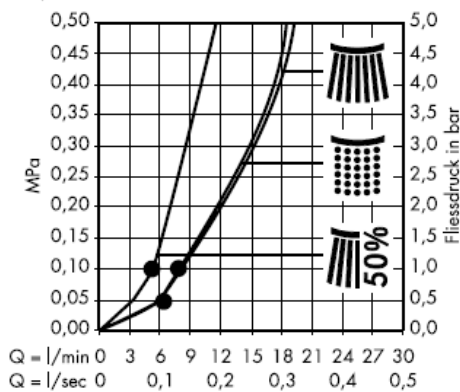
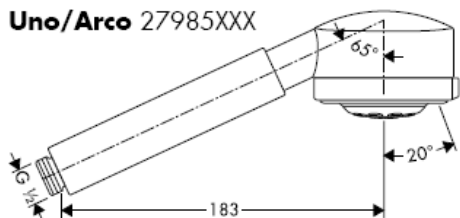

Normalstråle



Softstråle



Ecobrus 50%

Allegroh 27956000

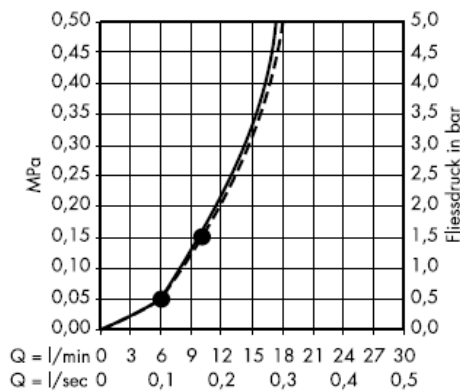
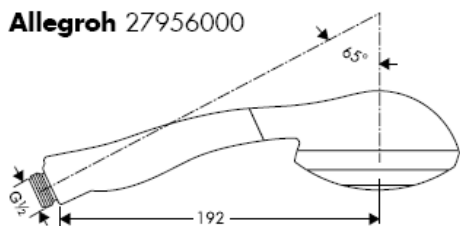

Normalstråle



Softstråle

Uno² 27986XXX

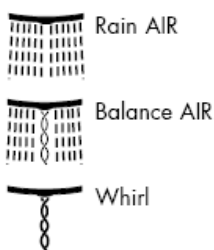
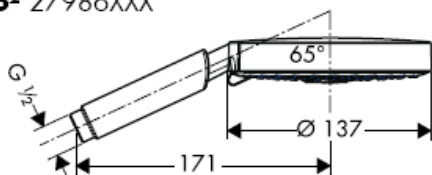

Med filterindsats (A)

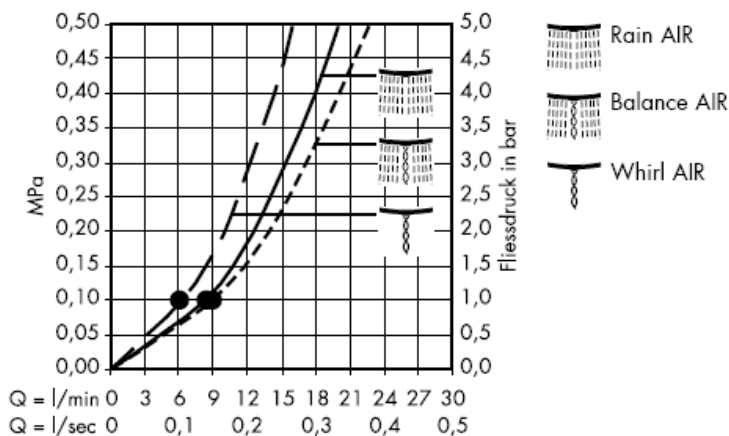

Med smudsfangsi (B)

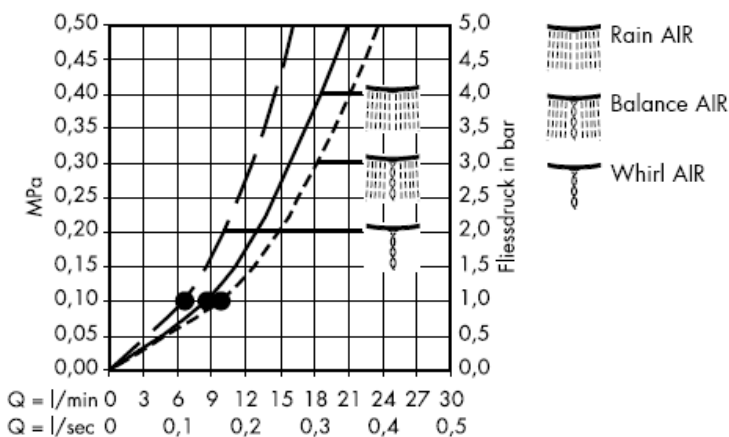

Fra • er funktionen anvendelig.

Afpas om muligt målene med fugerne.

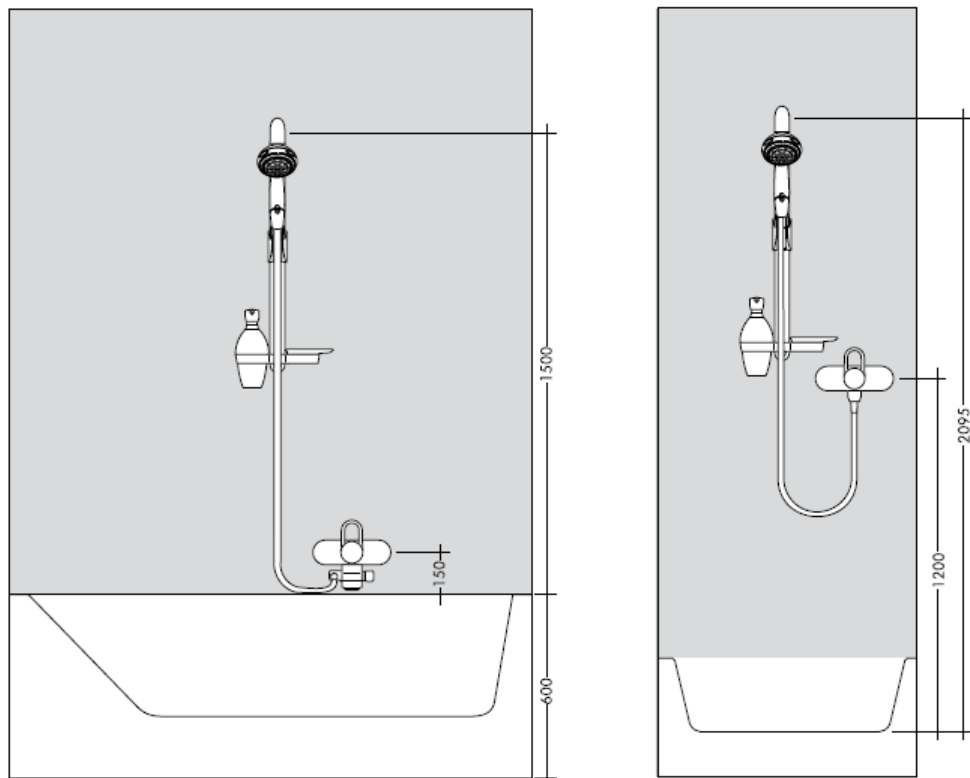

Ved montering er det vigtigt at sikre sig, at hele befæstigelsesfladen er plan (ingen ujævne fuger eller fliser), samt at væggen er egnet til montering af produktet og specielt, at væggen ikke har nogen svage punkter. De medfølgende skruer og dübler er kun egnet til beton. Ved anden vægopbygning bør producenten af dübler kontaktes for nærmere information.

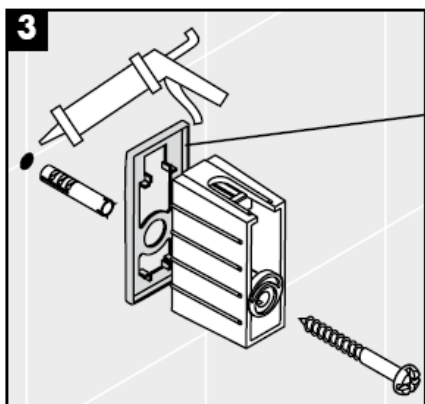
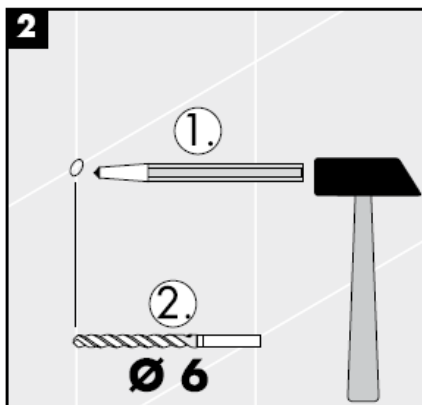
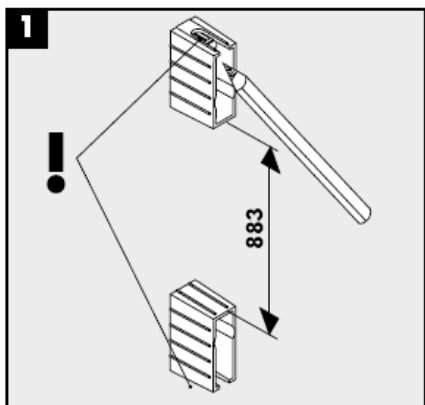

Dekoring kun i forbindelse med overfladen krom/guld!

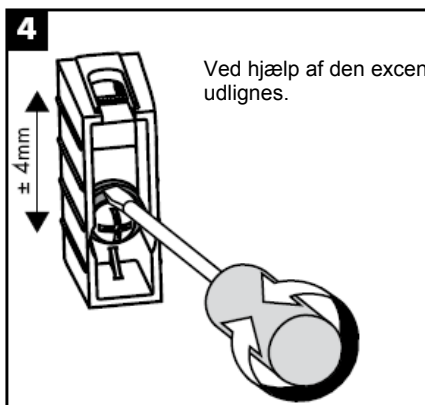

Ved hjælp af den excentriske bøsning kan evt. skævheder i borehullerne udlignes.

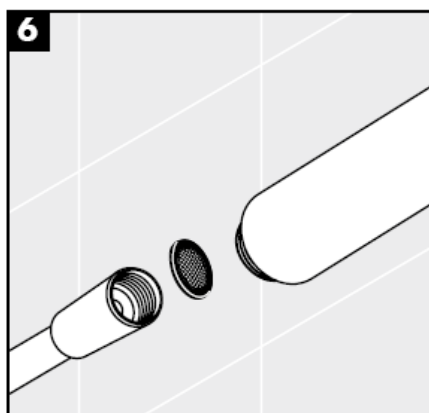
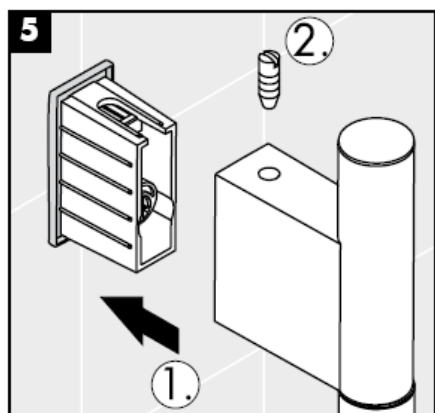

Den vedlagte smudsfangssi skal indsættes i bruseren for at undgå snavs fra rørsystemet. Indskyllet snavs kan have indflydelse på bruserens funktion og/eller føre til beskadigelser på håndbruserens funktionsdele.

Den vedlagte filterindsats (A) skal monteres for at sikre en normal vandgennemstrømning og for at forhindre at der kommer smuds i håndbruseren fra rørsystemet. Ønskes en større vandgennemstrømning skal filterindsatsen (A) erstattes med en smudsfangsi (B).

Snavs der er kommet ind i håndbruseren kan skade funktionsdelene i håndbruseren, og Hansgrohes garanti gælder ikke for skader der er opstået på denne måde.

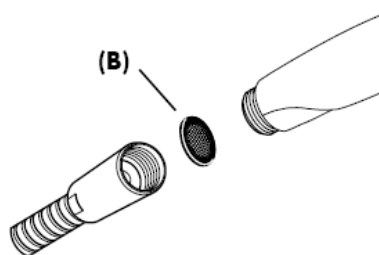
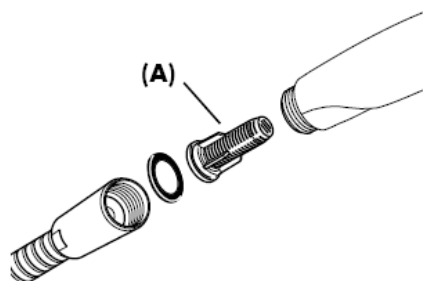

Justering

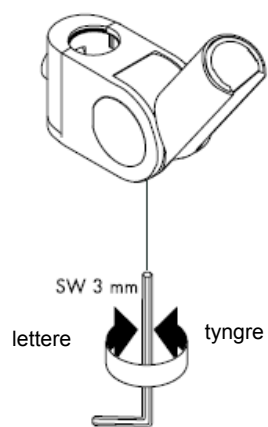
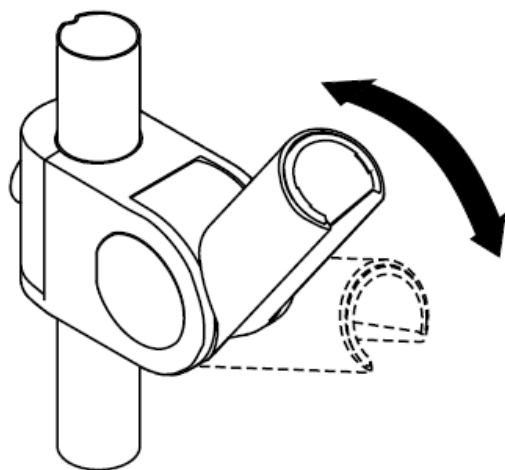
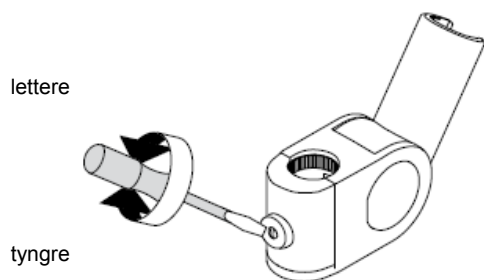
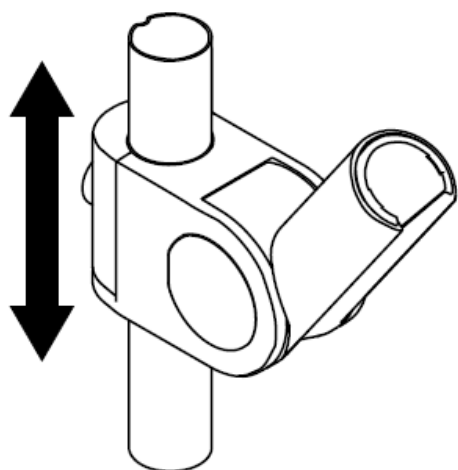

Rengøring

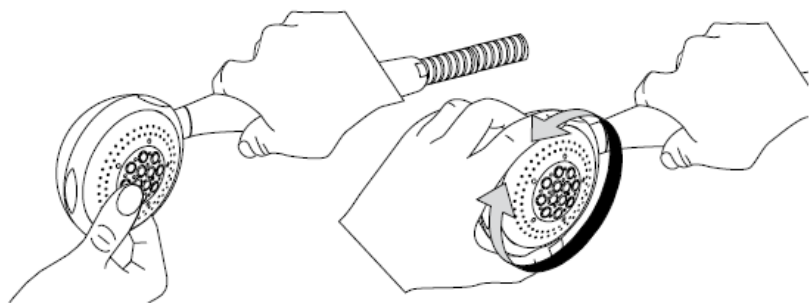

Med Rubit®, den manuelle rengøringsfunktion kan strålekanalerne let renses for kalk - der skal blot gnubbes!



Rengøring

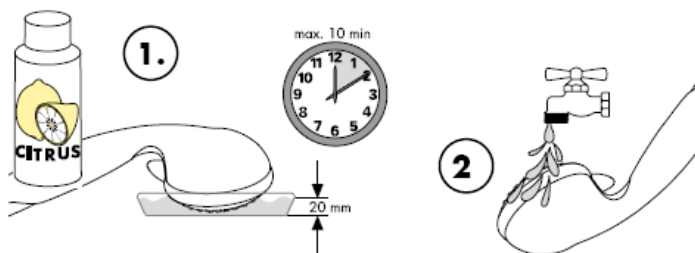

Rengøring

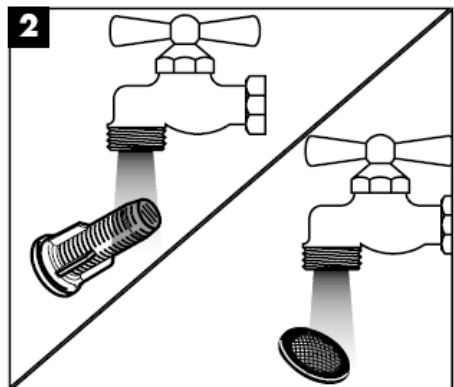
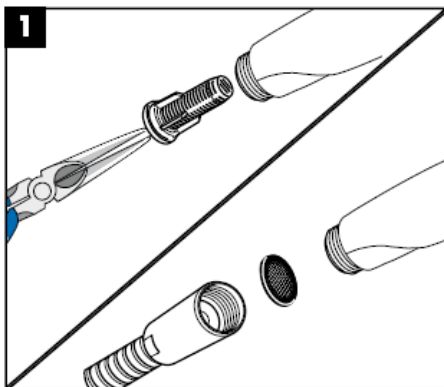
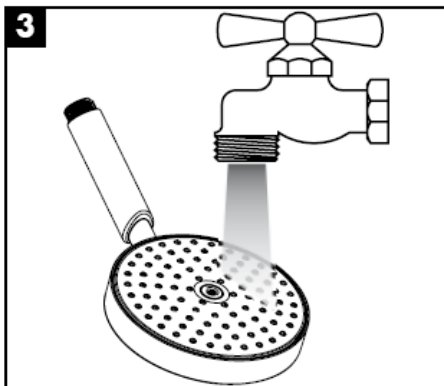
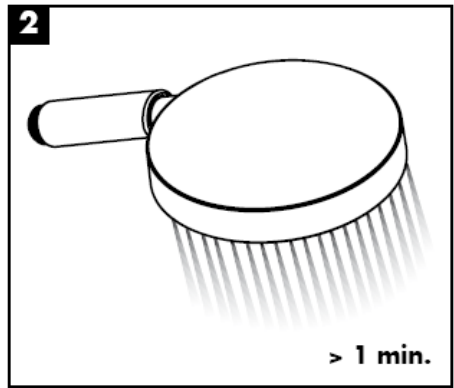
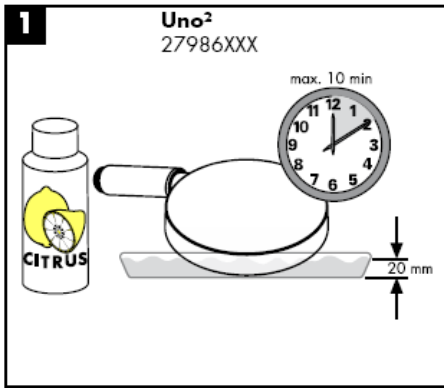

hansgrohe

Manual de Instalación

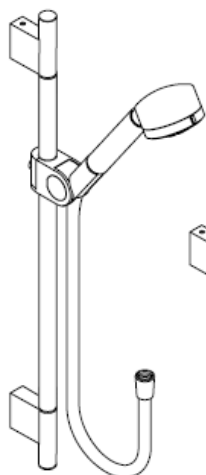

Uno/Arco
27985XXX

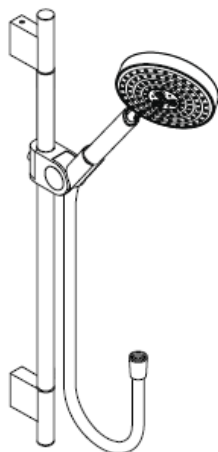

Uno²
27986XXX

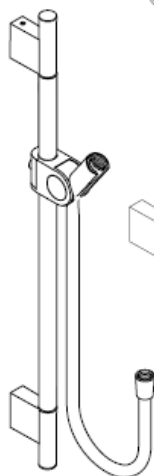

Uno
27989XXX

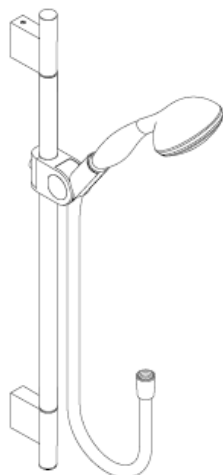

Allegroh
27956000

AXOR®

hansgrohe

Uno/Arco 27985XXX

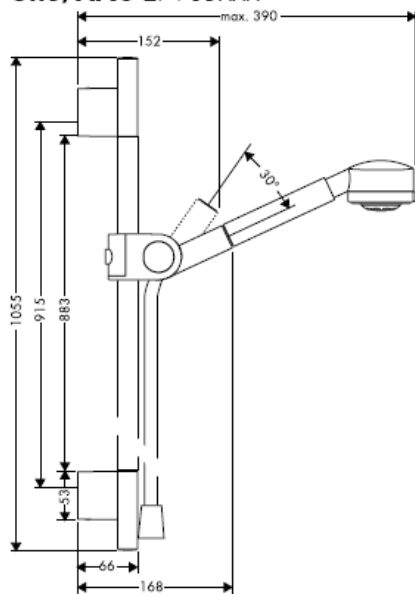

Uno² 27986XXX

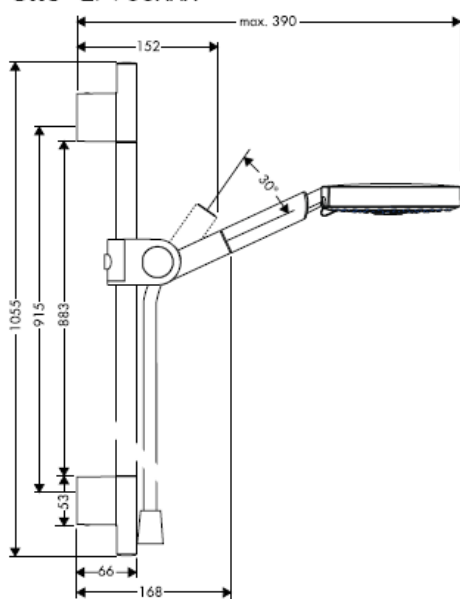

Uno 27989XXX

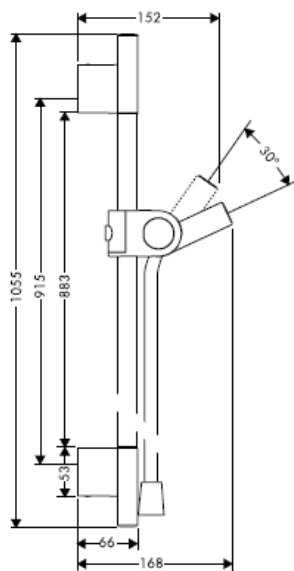

Allegroh 27956000

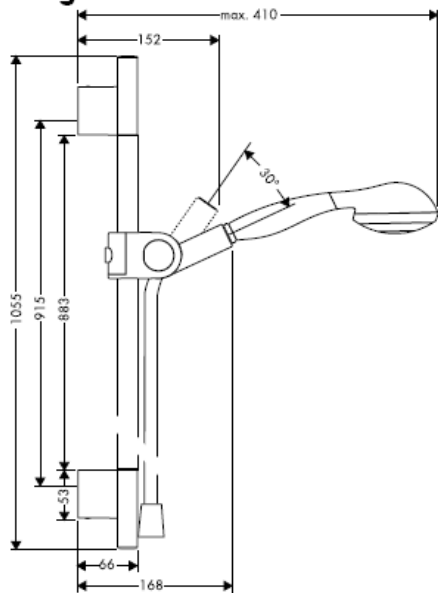



O bom funcionamento é apenas garantido em combinação com chuveiros de mão e tubos flexíveis Hansgrohe. Os tubos flexíveis são apenas adequados para uma ligação do chuveiro à misturadora. Nunca instale uma válvula de corte entre a misturadora e o tubo flexível.

Dados Técnicos

Pressão de funcionamento: max. 0,6 MPa
Pressão de func. recomendada: 0,1 – 0,4 MPa
(1 MPa = 10 bar = 147 PSI)
Temperatura da água quente: max. 60° C

O chuveiro de mão é compatível com esquentadores instantâneos de 21 kW e um caudal mínimo de 7 l/minuto.

Uno/Arco 27985XXX

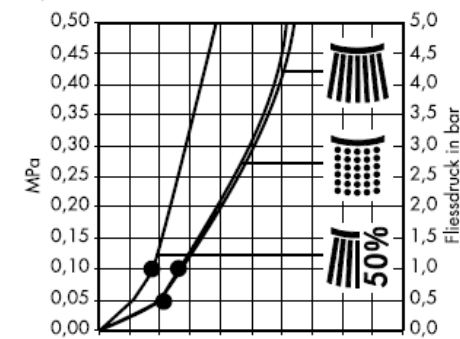
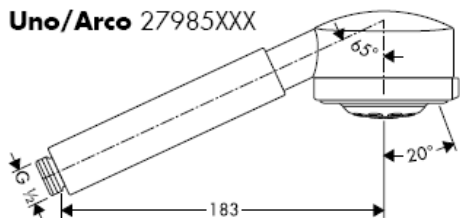

operação normal



operação soft



operação eco

Allegroh 27956000

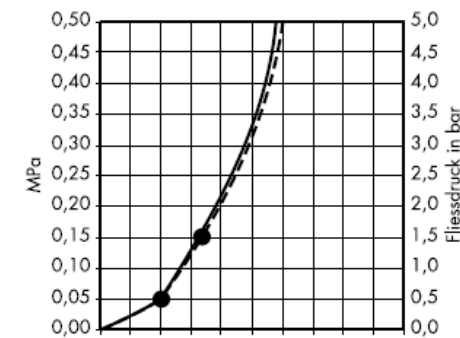
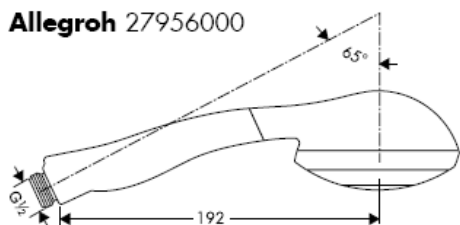

operação normal



operação soft

Uno² 27986XXX

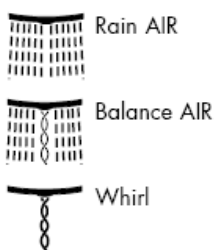
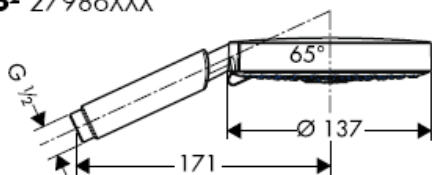

Com o filtro (A)

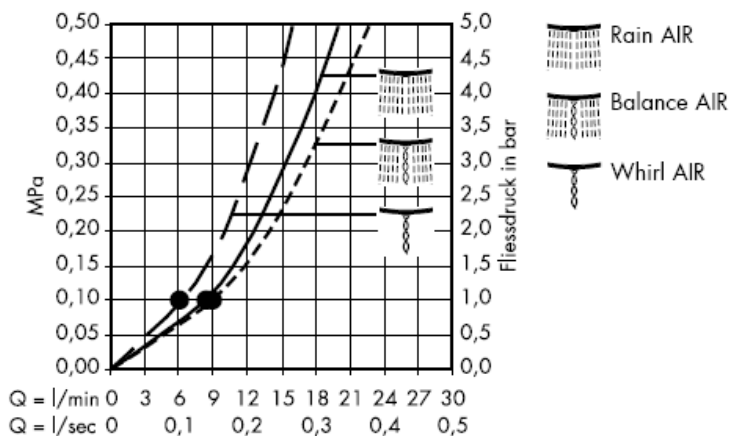

Com o filtro de junção (B)

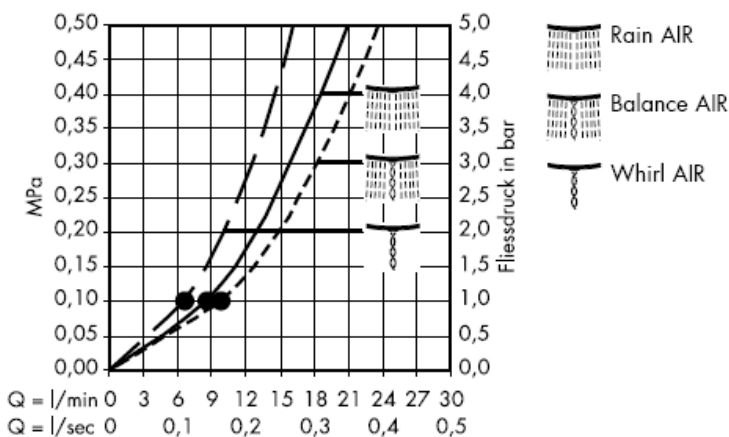

• A partir deste ponto inicia-se o funcionamento correcto.

Se possível adaptar às medidas dos azulejos.

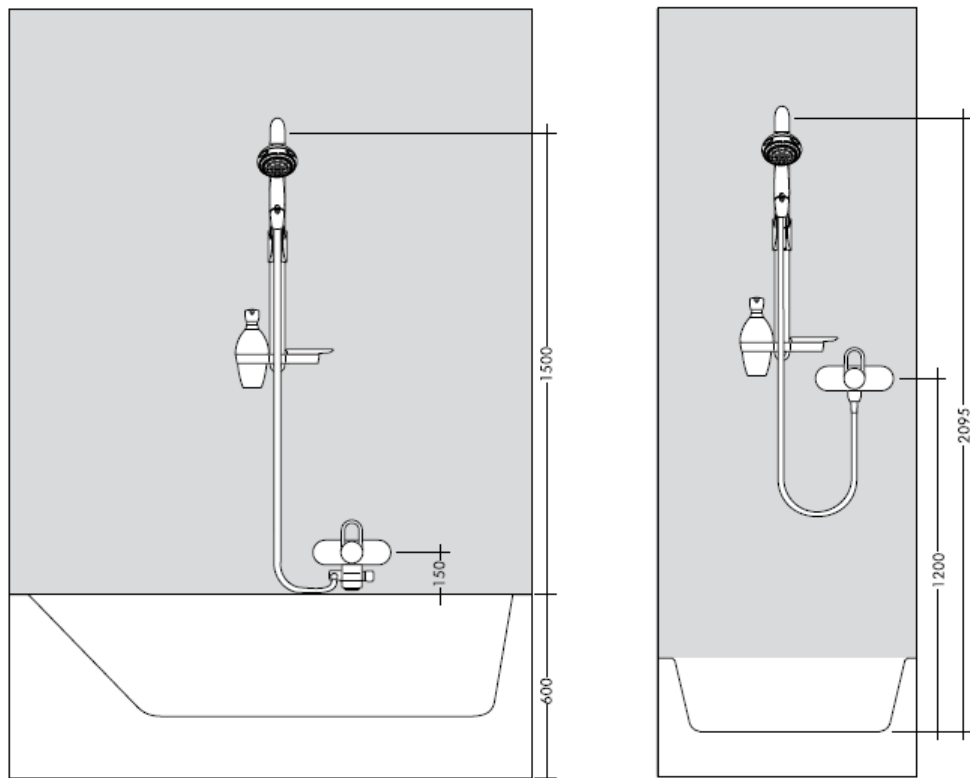

Durante a montagem do produto por técnicos qualificados, deve ter-se em atenção que a superfície de fixação seja plana em toda a área da fixação (sem juntas sobrepostas/salientes ou ladrilhos deslocados), que o dispositivo de montagem na parede seja adequado para uma montagem na parede e que este não apresente nenhuns pontos fracos.

Os parafusos e buchas incluídos no volume de fornecimento são apenas adequados para betão. Para outros métodos de montagem na parede devem ser respeitadas as indicações do fabricante das buchas.

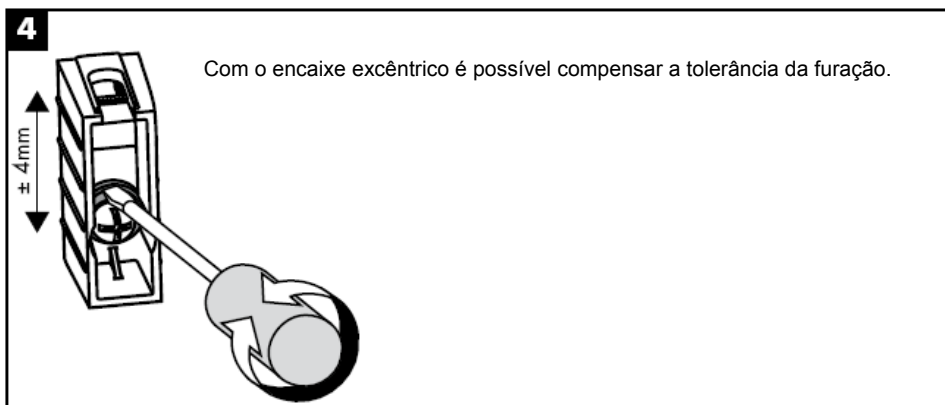
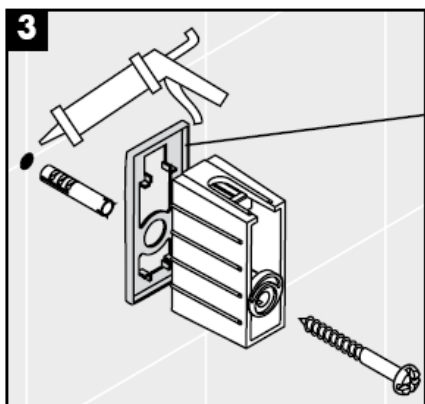
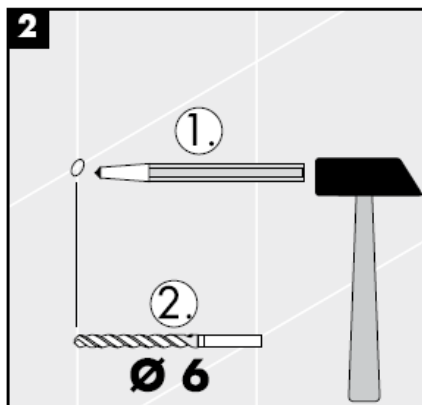
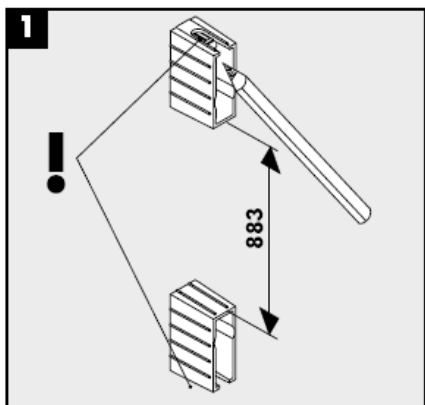

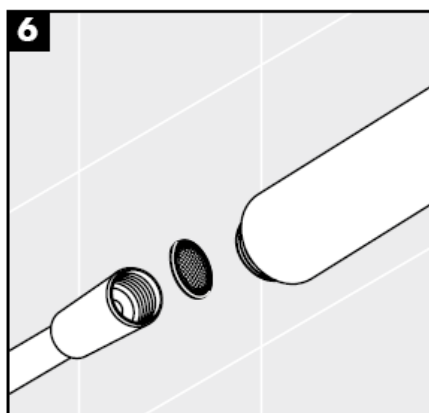
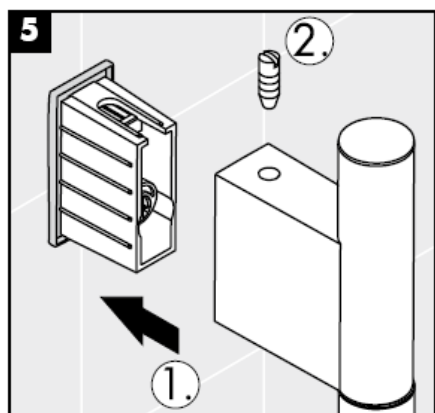

O filtro de rede deve ser colocado para proteger o chuveiro de areias e resíduos provenientes da tubagem. Resíduos e areias podem danificar componentes, ou provocar mau funcionamento do chuveiro; as avarias assim provocadas anulam a nossa responsabilidade e anulam a nossa garantia.

O filtro de inserção (A) deve ser utilizado para assegurar um caudal standard e para proteger o chuveiro de areias e resíduos provenientes da tubagem. Se quiser um caudal maior, deve usar o filtro de junção (B) em vez do filtro de inserção (A).

Resíduos e areias podem danificar componentes ou provocar o mau funcionamento do chuveiro; as avarias assim provocadas anulam a responsabilidade e garantia Hansgrohe.

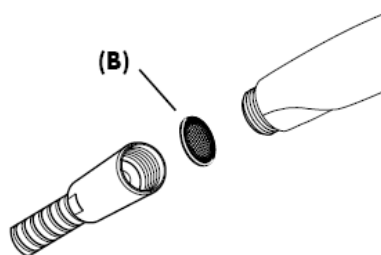
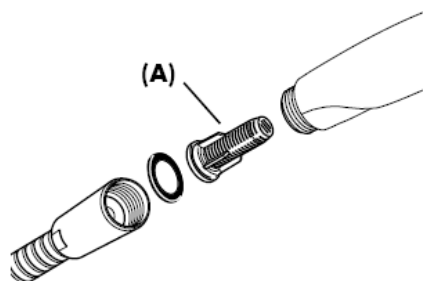

Afinação

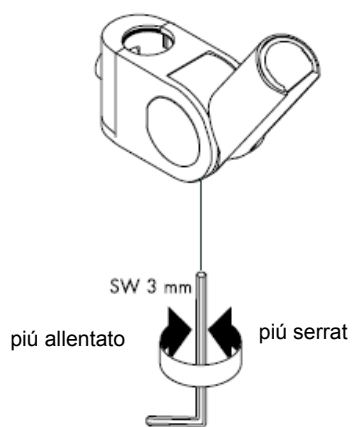
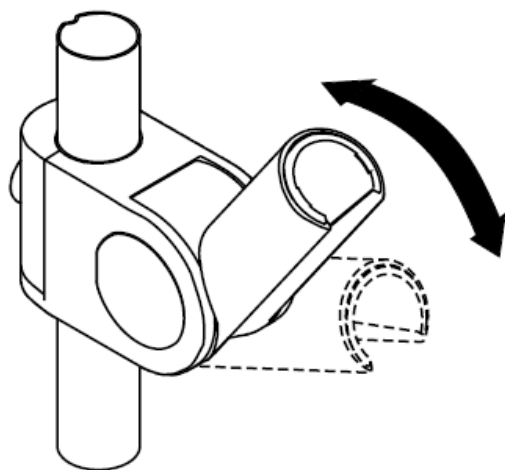
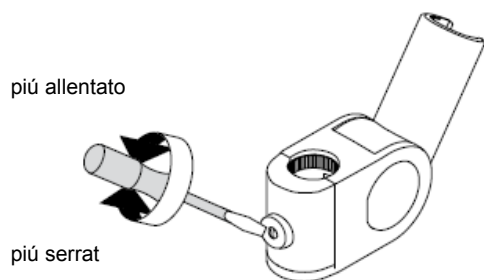
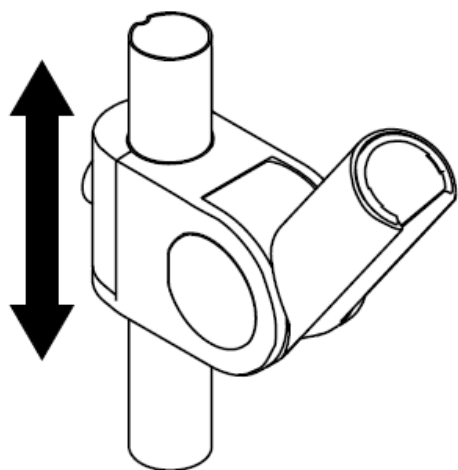

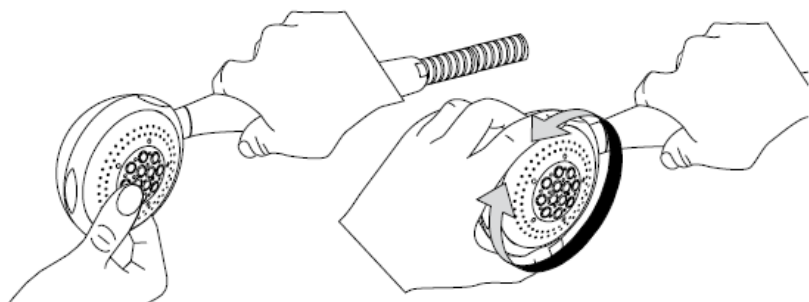

O sistema de limpeza Rubit® requer apenas uma ligeira passagem com a mão para remover os depósitos de calcário do emulsor.

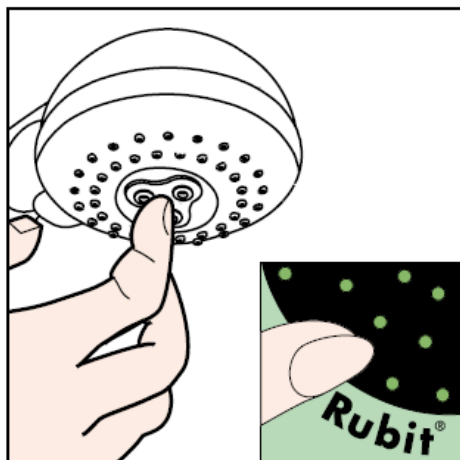

Instruções de Limpeza

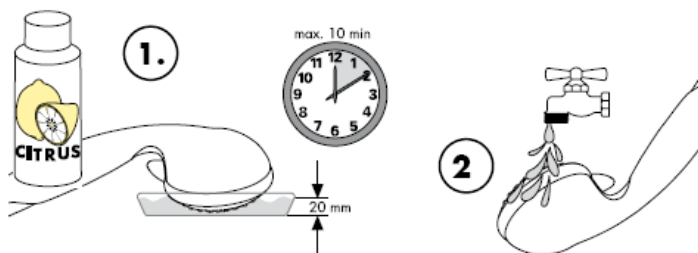

Limpeza

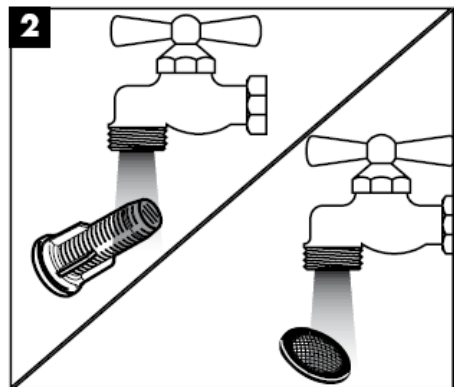
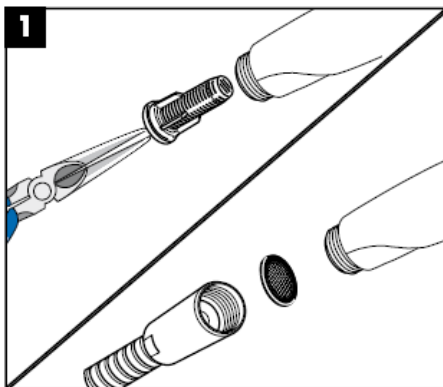
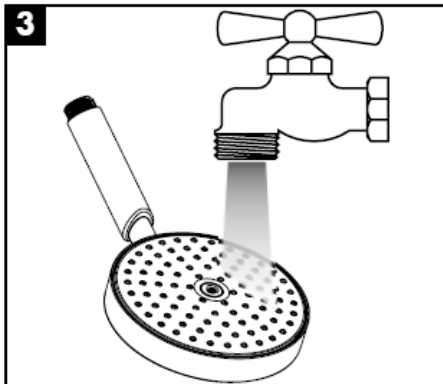
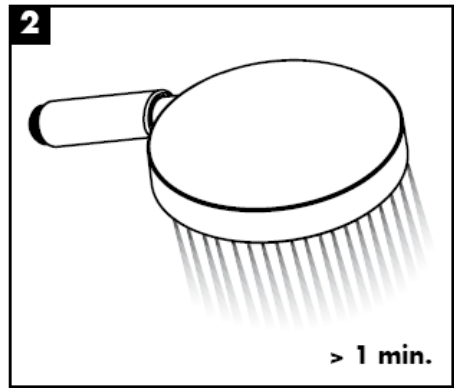
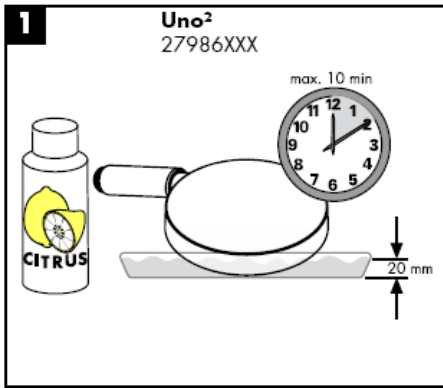

hansgrohe

Instrukcja montażu

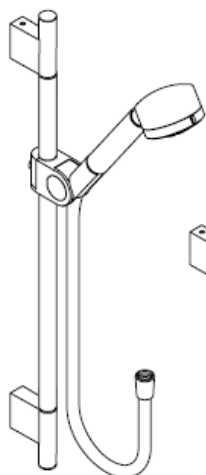

Uno/Arco
27985XXX

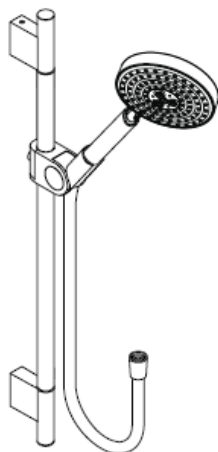

Uno²
27986XXX

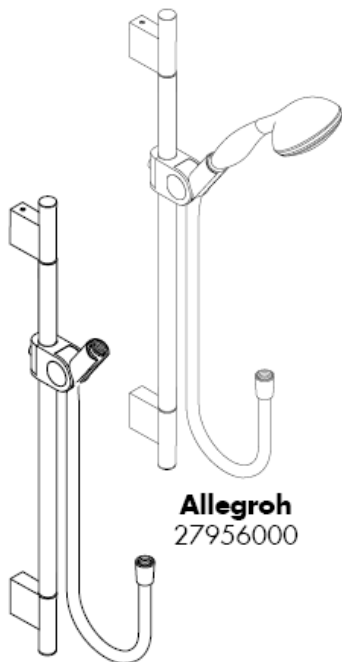

Allegroh
27956000

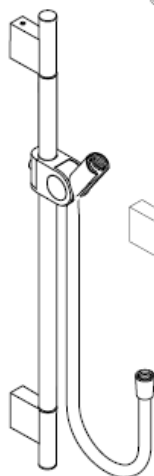

Uno
27989XXX

AXOR[®]

hansgrohe

Uno/Arco 27985XXX

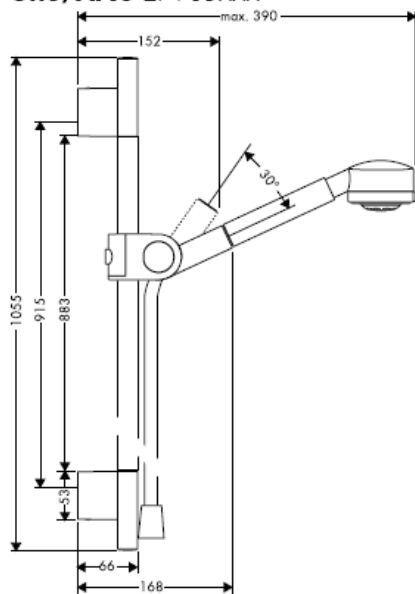

Uno² 27986XXX

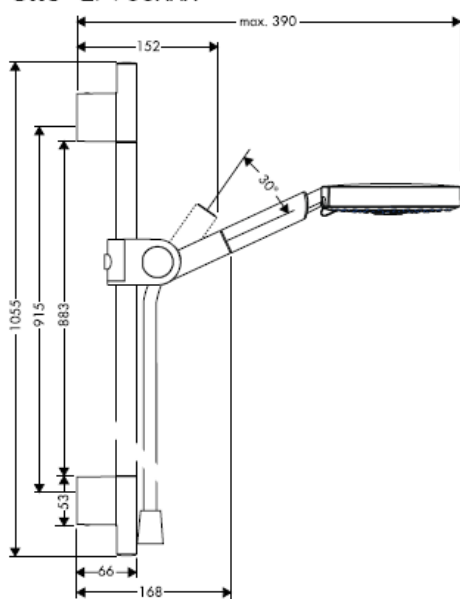

Uno 27989XXX

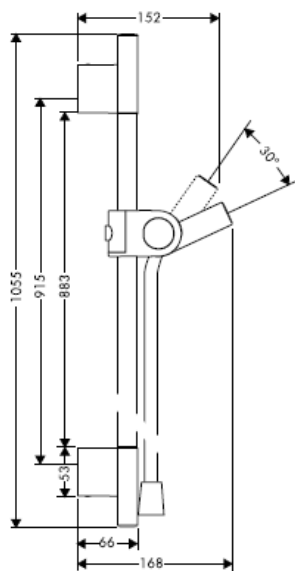

Allegroh 27956000

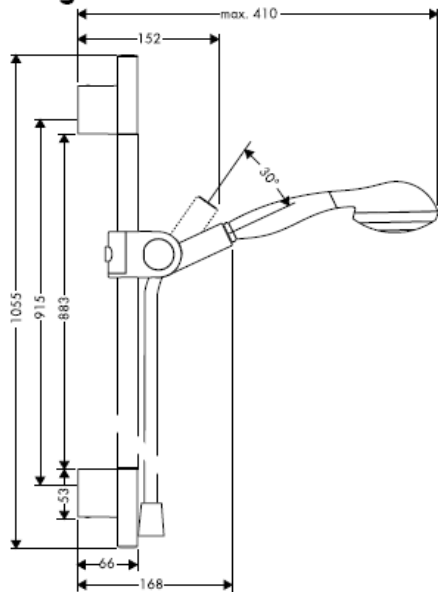



Optymalne działanie gwarantuje się tylko w odniesieniu do pryszniców ręcznych i węży prysznicowych Hansgrohe. Węże prysznicowe przeznaczone są do podłączenia tylko z armaturą. Blokada za wężem w kierunku przepływu jest niedopuszczalna.

Dane techniczne

Ciśnienie robocze:	max. 0,6 MPa
Zalecane ciśnienie robocze: (1 MPa = 10 bary = 147 PSI)	0,1 – 0,4 MPa
Temperatura wody gorącej:	max. 60° C

Prysznic ręczny jest przystosowany do przepływowych podgrzewaczy wody o mocy powyżej 21 kW i przepływie minimalnym 7 l/min.

Uno/Arco 27985XXX

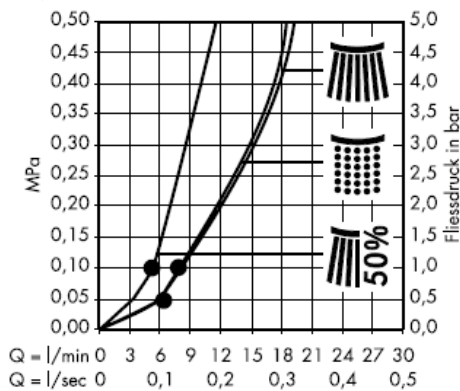
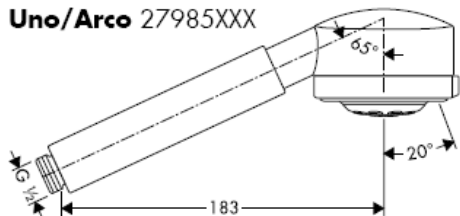

Strumień normalny



Strumień miękki



Strumień eco

Allegroh 27956000

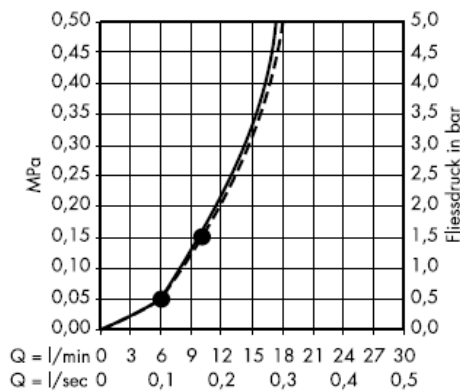
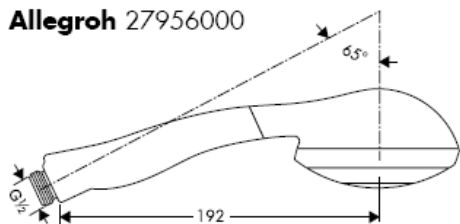

Strumień normalny



Strumień miękki

Uno² 27986XXX

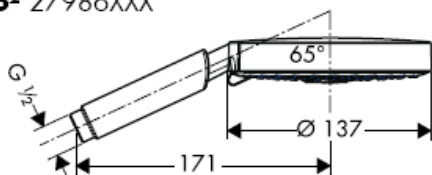

Rain AIR



Balance AIR



Whirl



Z wkładką filtra (A)

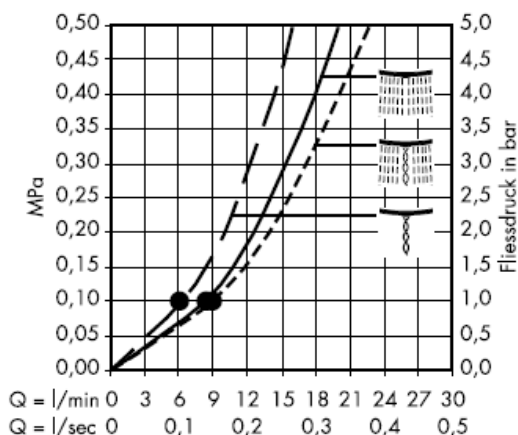

Rain AIR



Balance AIR



Whirl AIR



Z uszczelką z sitkiem (B)

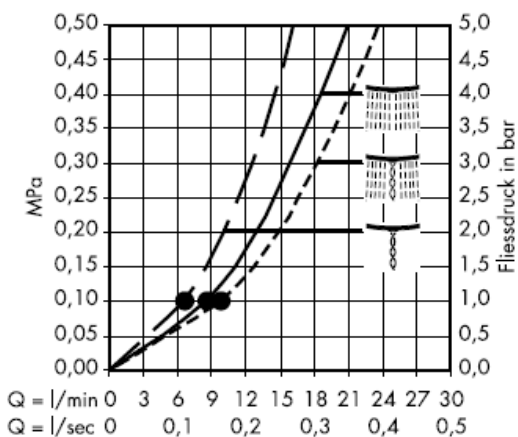

Rain AIR



Balance AIR



Whirl AIR



Od • możliwe jest funkcjonowanie.

Wymiary należy możliwie dopasować do układu płytek ceramicznych na ścianie.

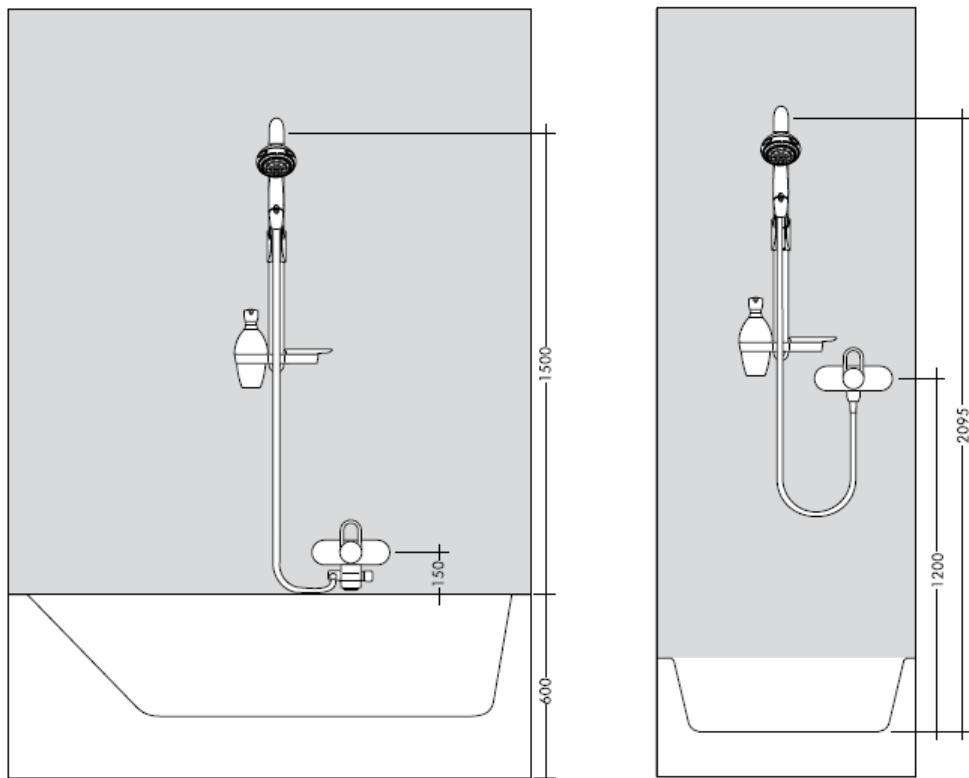

Przy montażu produktu przez wykwalifikowany personel fachowy należy zważać na to, by powierzchnia mocowania na całym obszarze mocowania była równa (by nie było szczelin wzgl. wzajemnie przesuniętych płytek), rodzaj ściany nadawał się do montażu produktu i zwłaszcza, by nie było żadnych słabych stron. Umieszczone w dostawie śruby i kołki rozporowe są przeznaczone tylko do betonu. Przy innych rodzajach montażu ściannowego należy przestrzegać danych producenta kołków rozporowych.

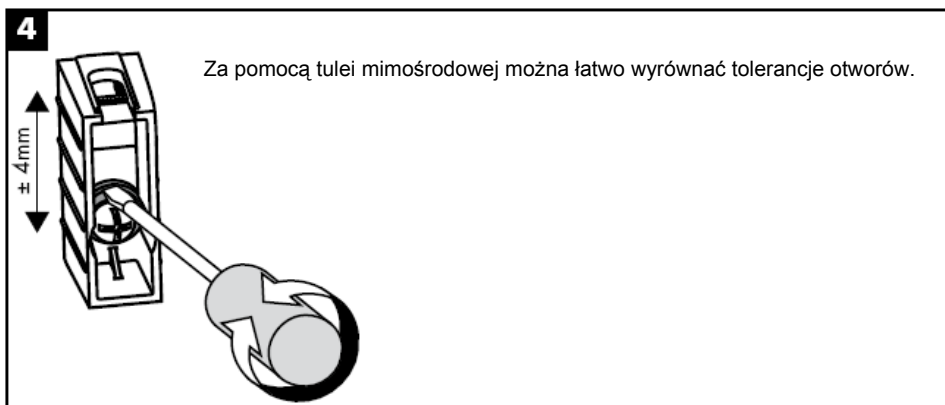
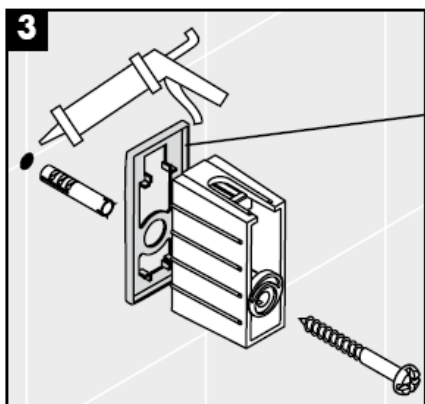
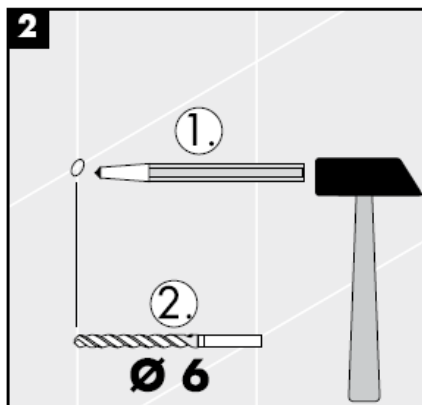
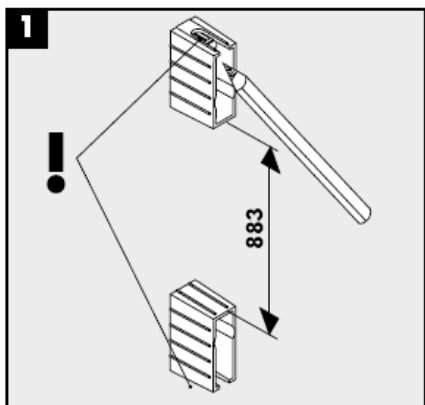

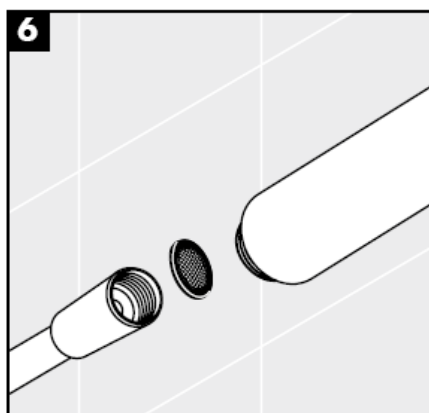
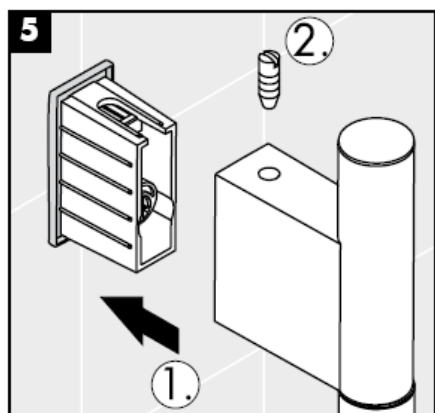

Znajdujące się przy prysznicu sitko musi zostać zainstalowane, aby zatrzymać zanieczyszczenia z instalacji. Przedostające się zanieczyszczenia mogą mieć ujemny wpływ na działanie i/lub prowadzić do usterek w działaniu elementów prysznicza. Za powstałe z tego tytułu szkody firma Hansgrohe nie ponosi odpowiedzialności.

Należy zamontować znajdującą się w opakowaniu wkładkę filtra (A), aby zapewnić przepisowy przepływ przez prysznic ręczny i zapobiec przedostawaniu się zanieczyszczeń z instalacji sieciowej. Jeżeli pożądanym jest większy przepływ wody, wówczas należy zamiast wkładki filtra (A) użyć uszczelki z sitkiem (B). Przedostające się zanieczyszczenia mogą mieć negatywny wpływ na działanie i/lub prowadzić do usterek w działaniu elementów prysznicza ręcznego. Za powstałe z tego tytułu szkody firma Hansgrohe nie ponosi odpowiedzialności.

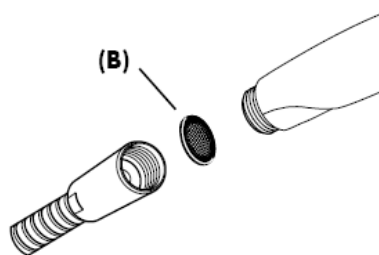
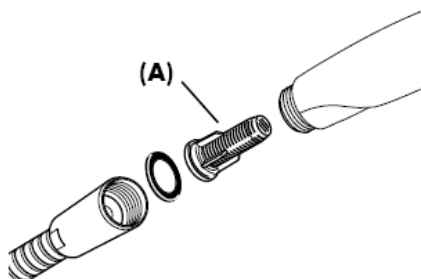

Regulacja

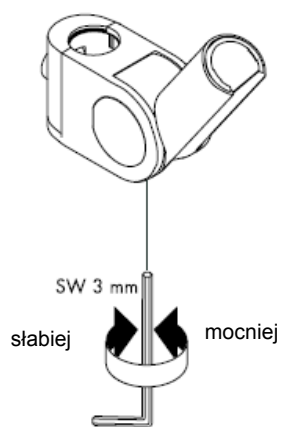
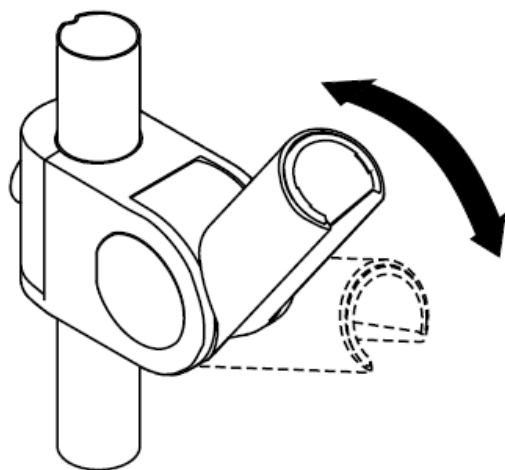
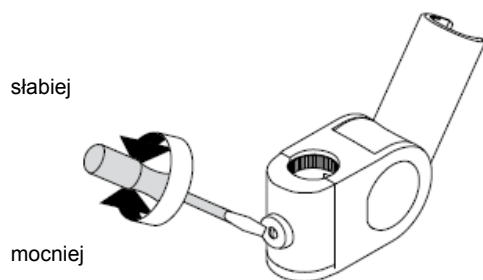
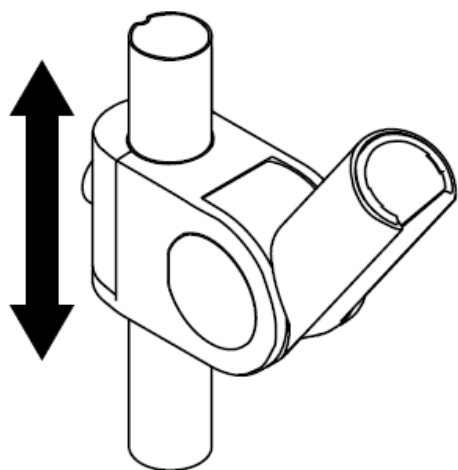

Czyszczenie

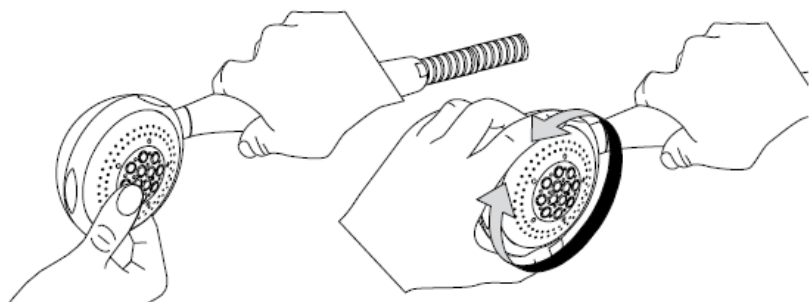

Funkcja Rubit® wymaga jedynie delikatnego potarcia dłonią, aby usunąć ewentualne osady kamienia wapiennego.



Instrukcja pielęgnacji

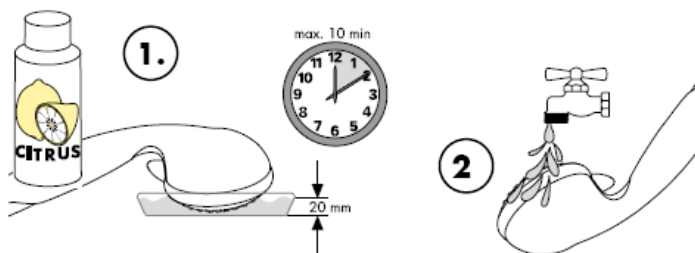

Czyszczenie

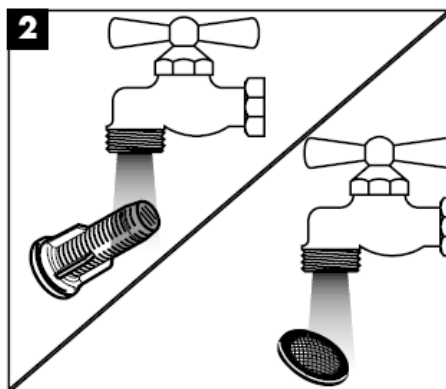
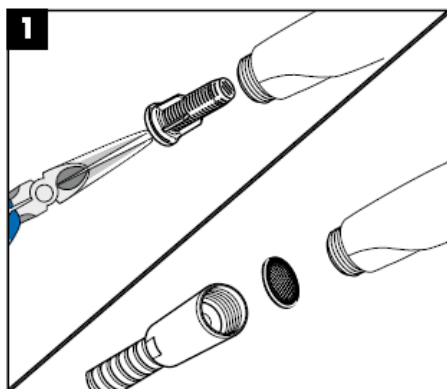
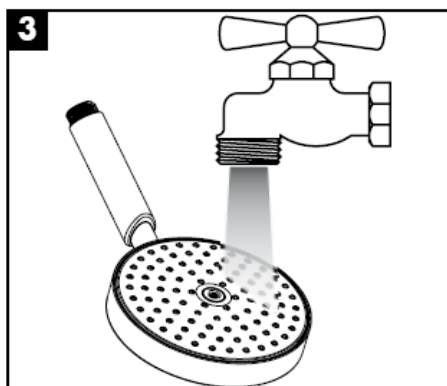
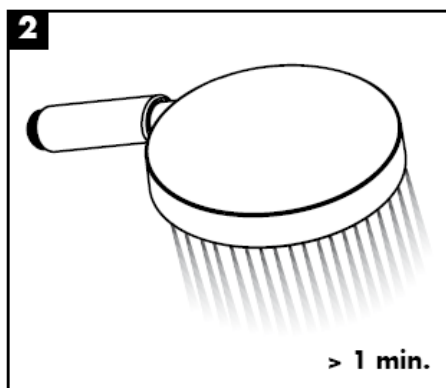
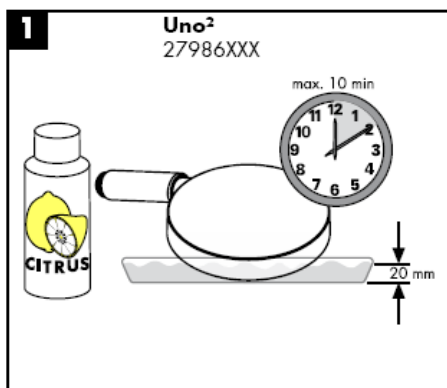

hansgrohe

Montážní návod

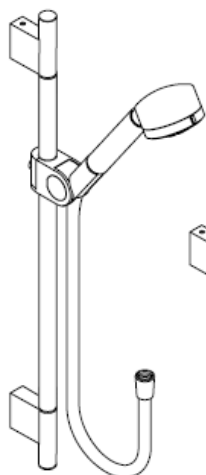

Uno/Arco
27985XXX

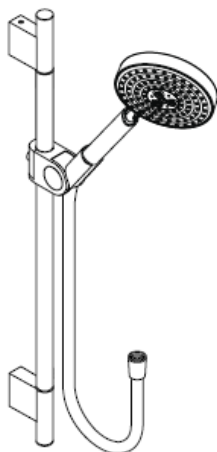

Uno²
27986XXX

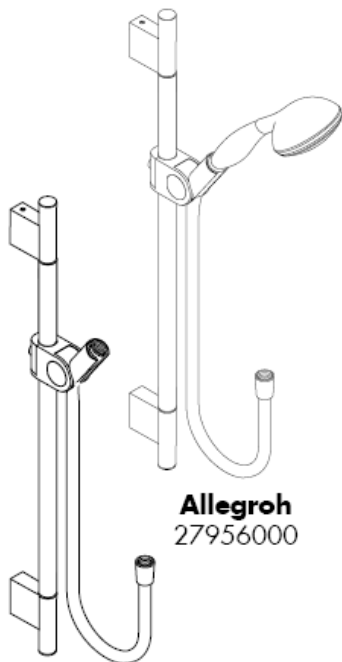

Allegroh
27956000

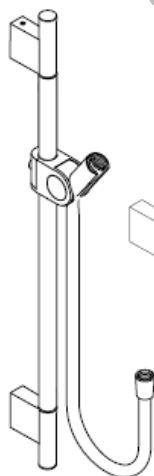

Uno
27989XXX

AXOR[®]
hansgrohe

Uno/Arco 27985XXX

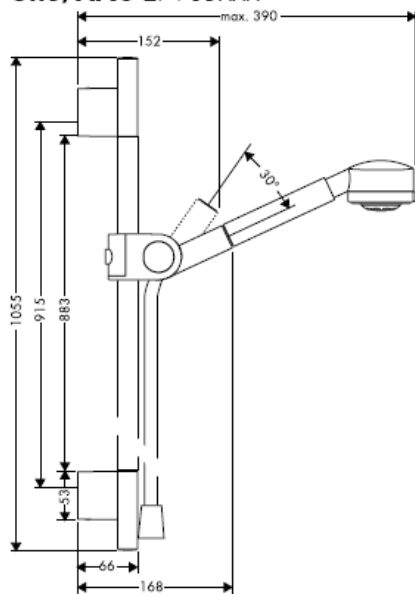

Uno² 27986XXX

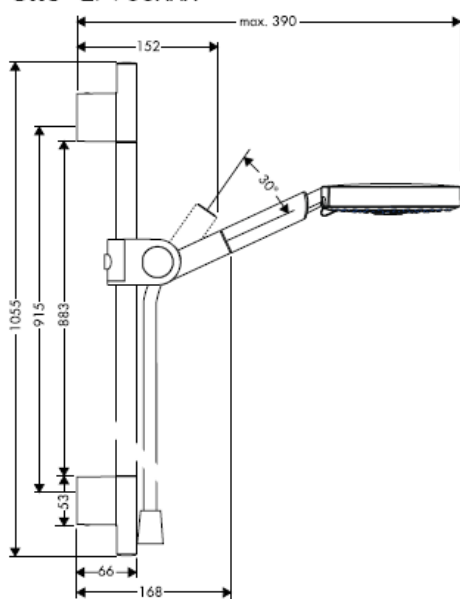

Uno 27989XXX

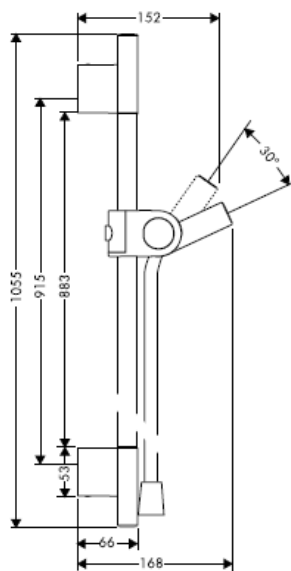

Allegroh 27956000

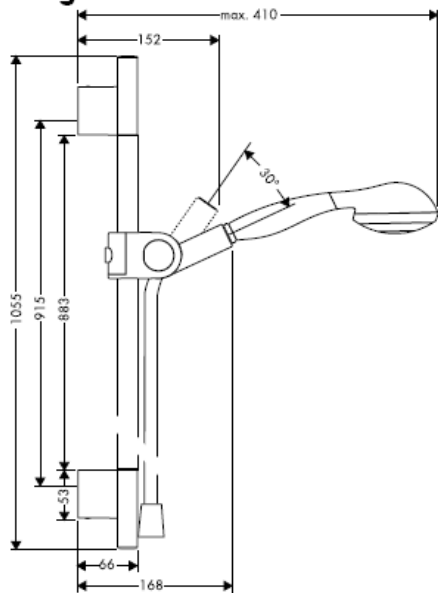



Optimální funkce je zaručena pouze s ručními sprchami a sprchovými hadicemi Hansgrohe. Sprchové hadice jsou vhodné pouze pro napojení sprch na armatury. Řazení uzavíracího ventilu za hadici po směru toku je nepřípustné!

Technické údaje

Provozní tlak:	max. 0,6 MPa
Doporučený provozní tlak: (1 MPa = 10 bar = 147 PSI)	0,1 – 0,4 MPa
Teplota horké vody:	max. 60° C

Ruční sprcha je vhodná k použití s průtokovým ohřívačem výkonu od 21 kW a průtoku 7 l/min.

Uno/Arco 27985XXX

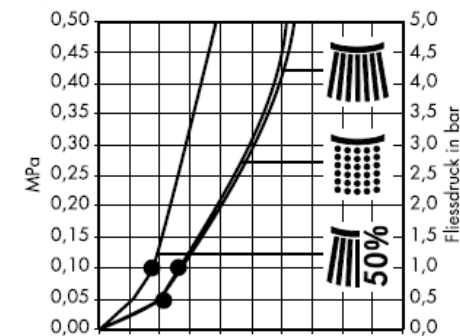
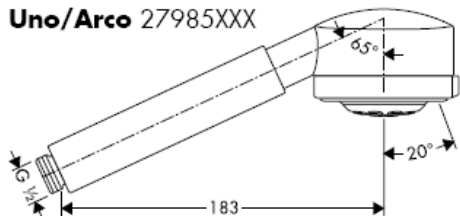

Normální proud



Jemný proud



Eco proud

Allegroh 27956000

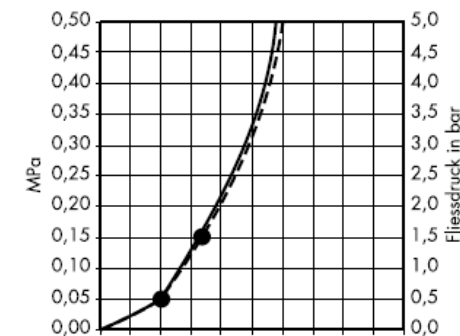
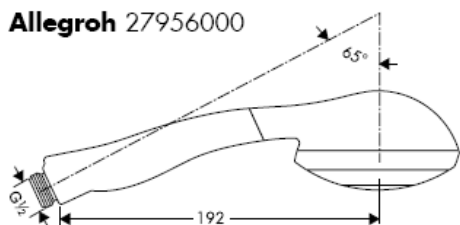

Normální proud



Jemný proud

Uno² 27986XXX

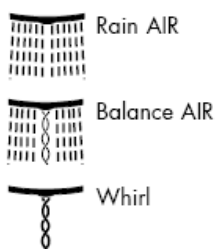
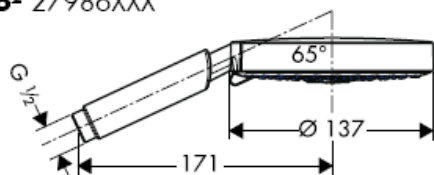

s filtrační vložkou (A)

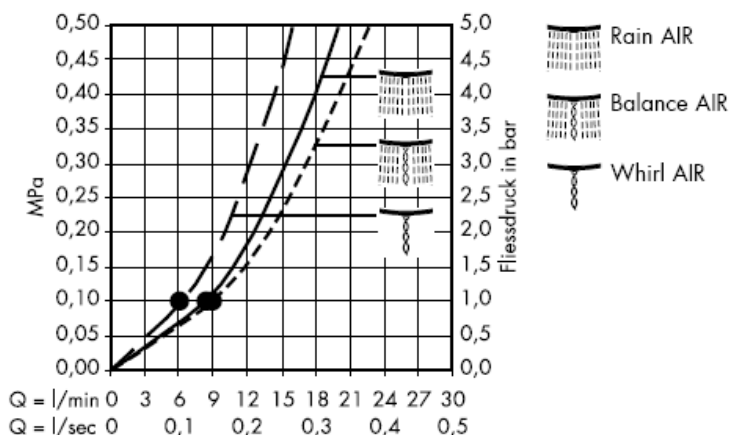

S těsněním se sítkem (B)

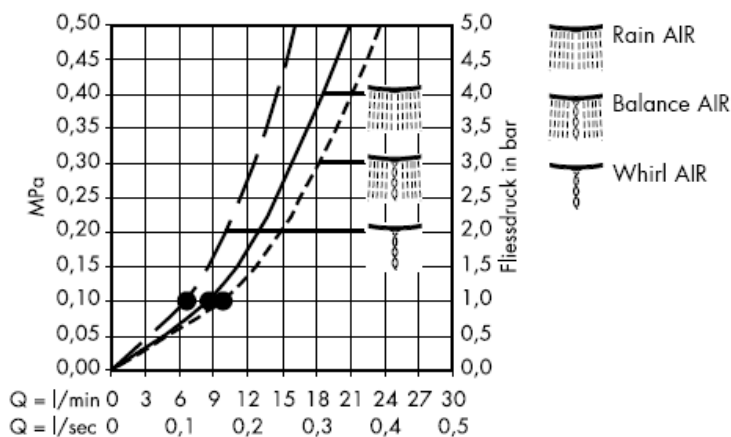

Od • je zaručená funkce

Rozměry pokud možno přizpůsobit rozložení obkladů.

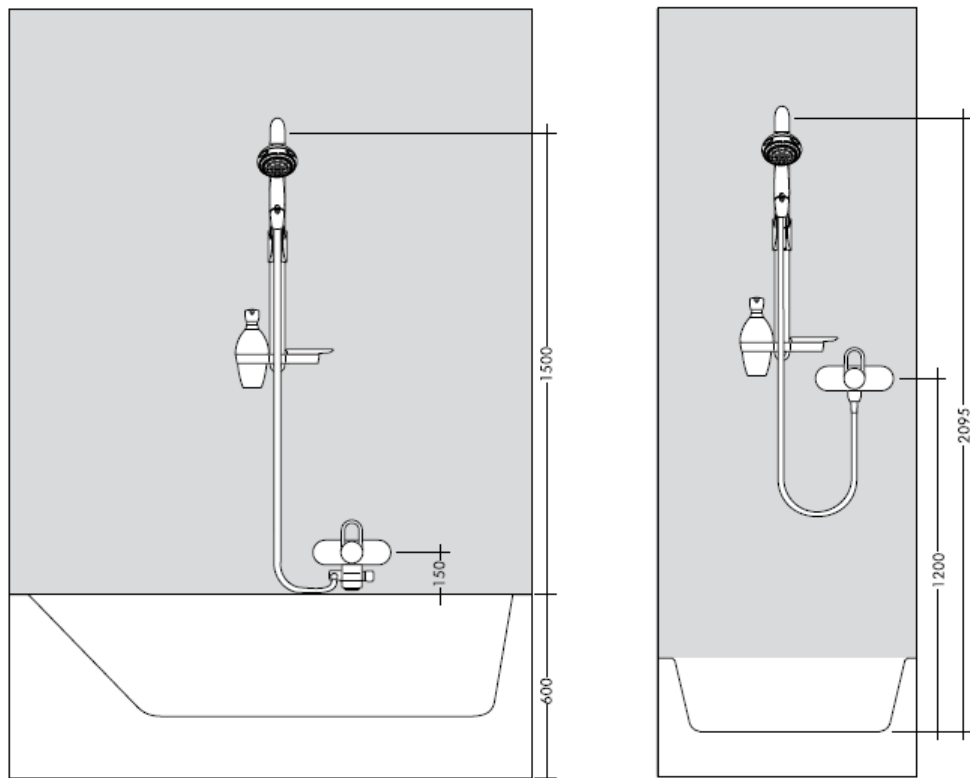

Při montáži produktu kvalifikovaným odborným personálem je třeba dbát na to, aby upevňovací plochy byly v celém rozsahu upevnění rovné (žádné vyčnívající spáry nebo navzájem přesazené obklady), aby konstrukce stěny byla pro montáž produktu vhodná a zvláště aby v ní nebyla žádná slabá místa. Přiložené vruty a hmoždinky jsou vhodné pouze pro beton. Při jiných konstrukčních materiálech stěny je třeba se řídit údaji výrobce hmoždinek.

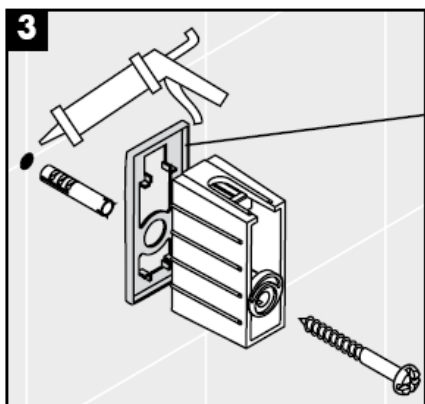
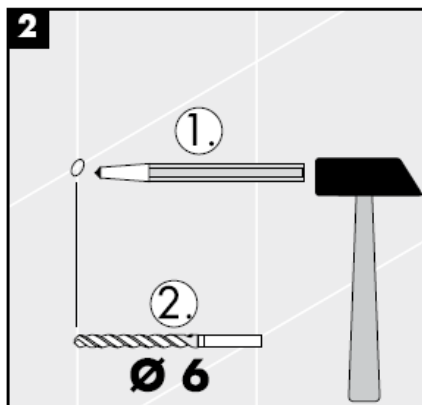
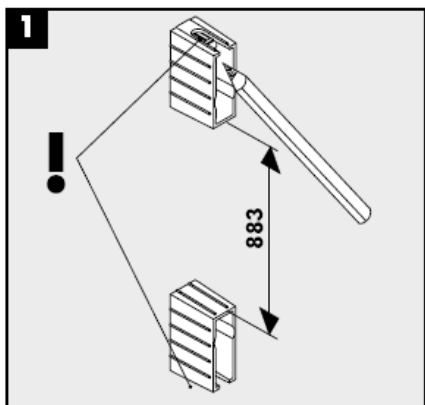

Ozdobný kroužek pouze u varianty chróm/zlato!

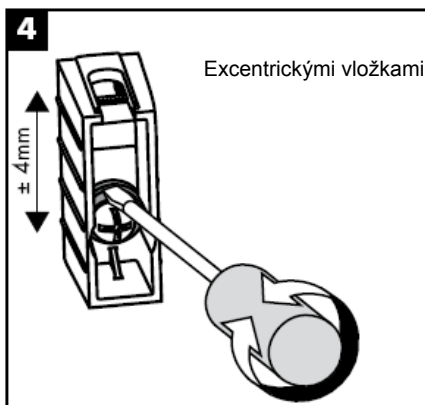

Excentrickými vložkami je možné vyrovnat tolerance vrtaných otvorů.

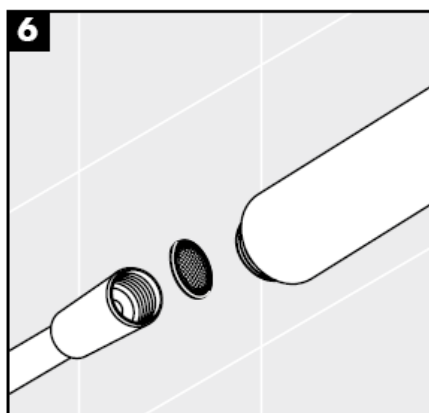
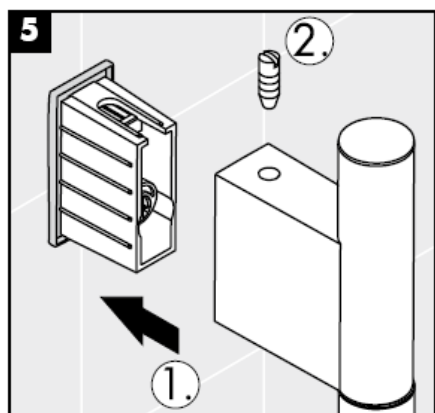

Do přívodu musí být zabudováno se sprchou dodávané sítko, aby zachycovalo nečistoty vyplavené z vodovodní sítě. Vyplavené nečistoty mohou ovlivnit funkci sprchy a nebo mohou vést i k jejímu poškození. Na takto vzniklé škody se nevztahuje záruka firmy Hansgrohe.

Příbalená filtrační vložka (A) se musí zabudovat, aby zajistila jmenovitý průtok ruční sprchou a zabránila přístupu nečistot vyplavovaných z potrubí. Pokud se požaduje vyšší průtok, musí se vsadit místo filtrační vložky (A) těsnění se sítkem (B). Vyplavené nečistoty mohou ovlivnit funkčnost a nebo také vést k poškození funkčních dílů ruční sprchy. Na tyto škody se záruka firmy Hansgrohe nevztahuje.

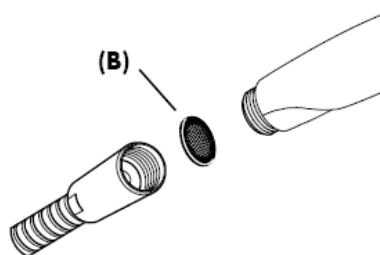
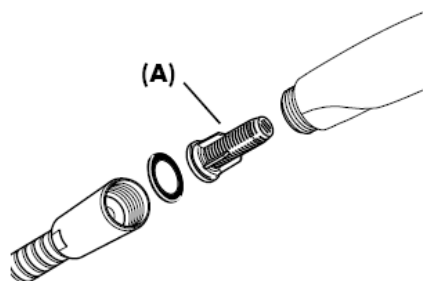

Nastavení

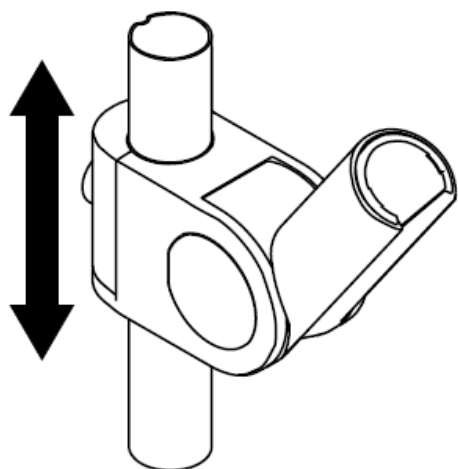

snazší

obtížnější

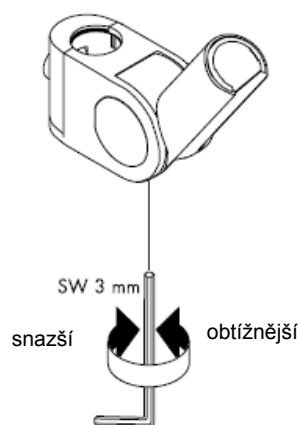
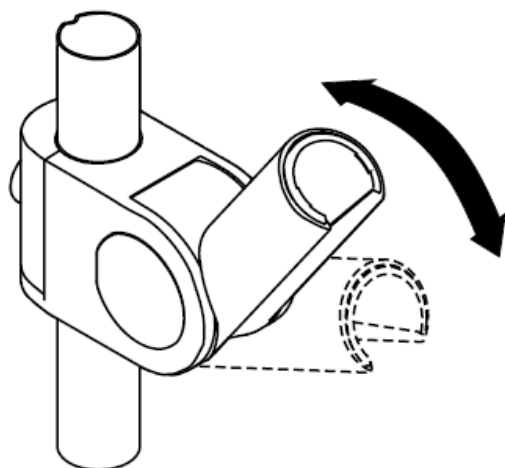
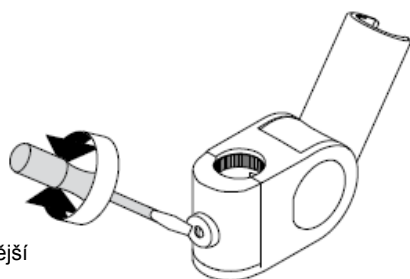

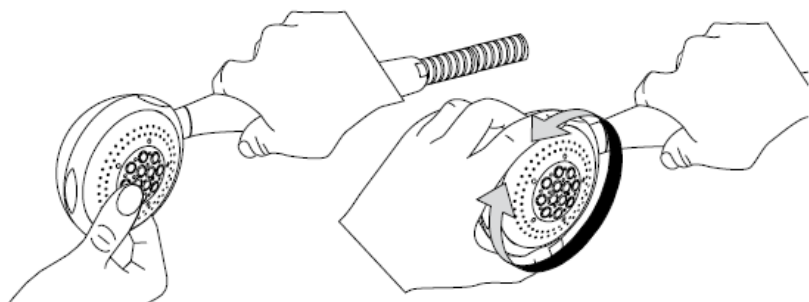

S ruční čisticí funkcí Rubit® stačí jednoduché odstranění vodního kamene prsty z trysek kotouče tvarujícího proud vody.



Návod na čištění

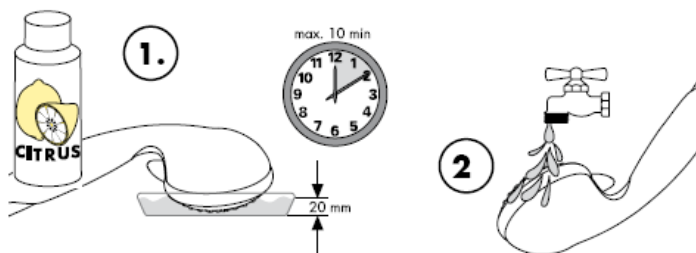

Čištění

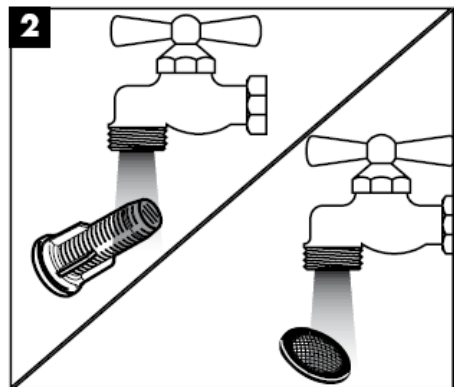
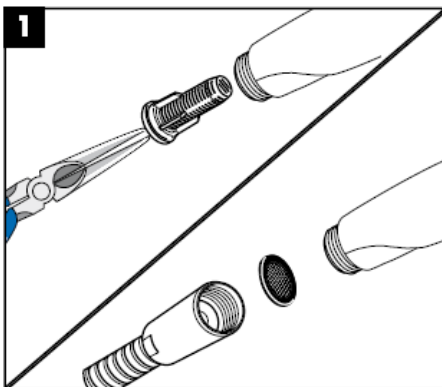
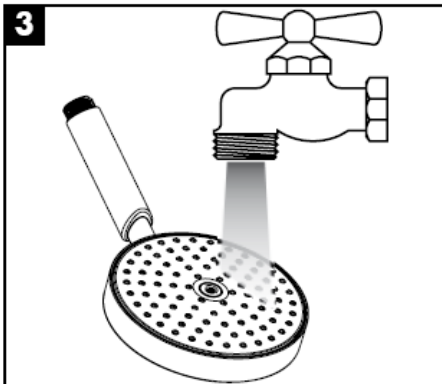
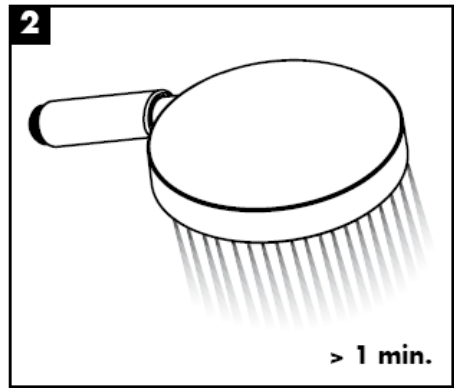
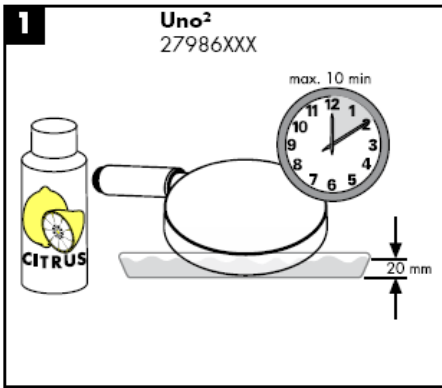

hansgrohe

Montážny návod

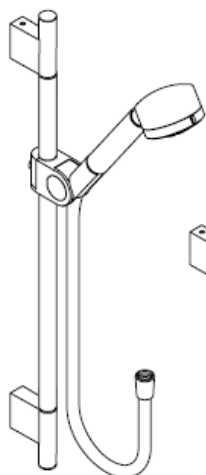

Uno/Arco
27985XXX

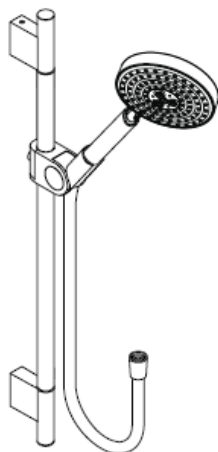

Uno²
27986XXX

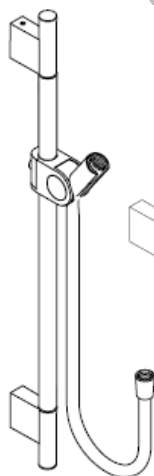

Uno
27989XXX

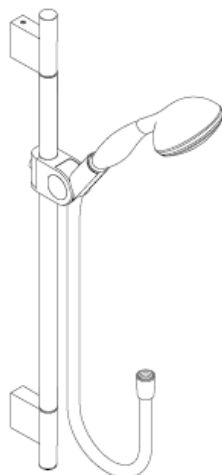

Allegroh
27956000

AXOR®

hansgrohe

Uno/Arco 27985XXX

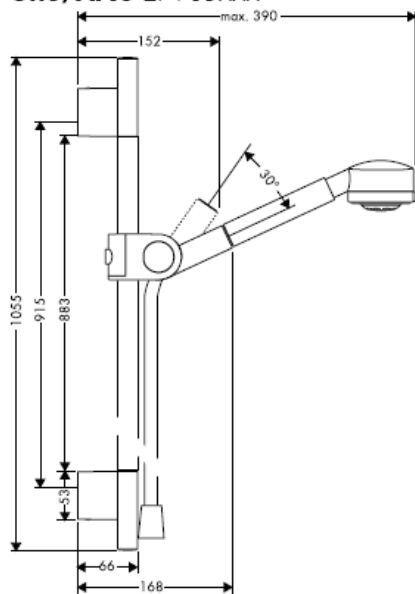

Uno² 27986XXX

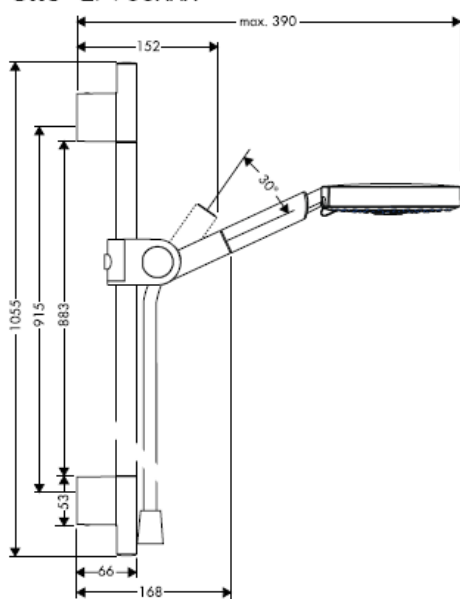

Uno 27989XXX

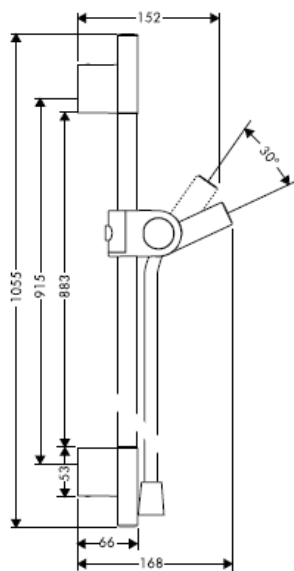

Allegroh 27956000

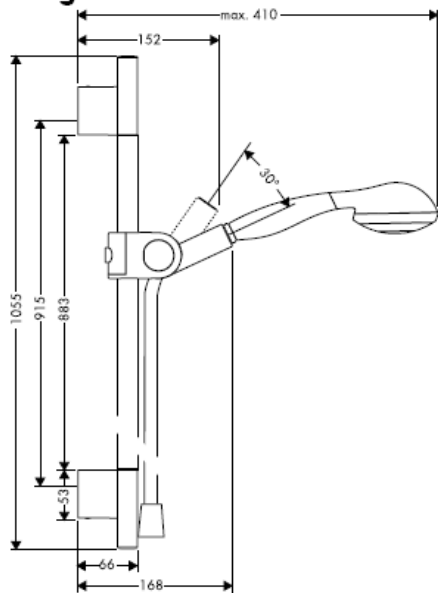



Optimálna funkcia je zaručen iba s ručnými sprchami a sprchovými hadicami Hansgrohe. Sprchové hadice sú vhodné iba pre napojenie sprch na batérie. Umiestnenie uzatváracieho ventilu za hadicou v smere toku je neprípustne.

Technické údaje

Prevádzkový tlak: max. 0,6 MPa
Doporučený prevádzkový tlak: 0,1 – 0,4 MPa
(1 MPa = 10 bar = 147 PSI)
Teplota teplej vody: max. 60° C

Ručná sprcha je vhodná k použitiu s prietokovým ohrievačom s výkonom od 21 kW a prietoku 7 l/min.

Uno/Arco 27985XXX

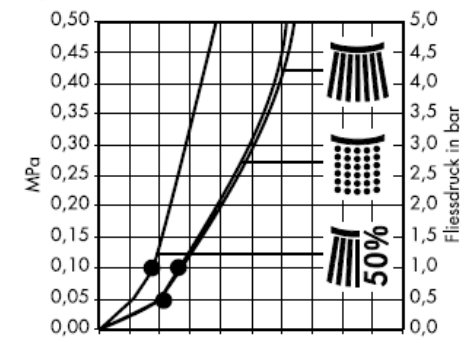
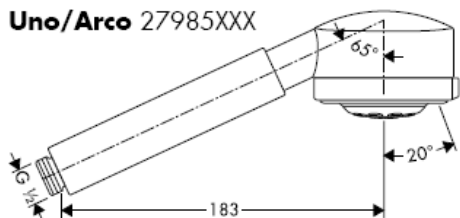

Normálny prúd



Mierny prúd



Eco prúd

Allegroh 27956000

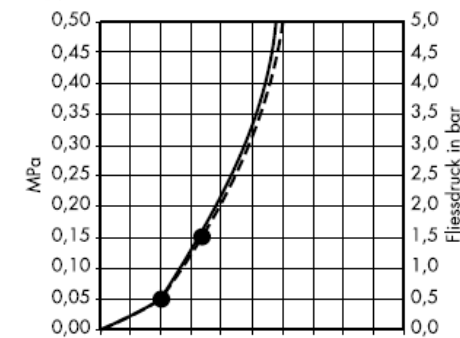
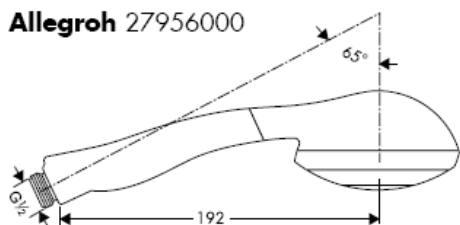

Normálny prúd



Mierny prúd

Uno² 27986XXX

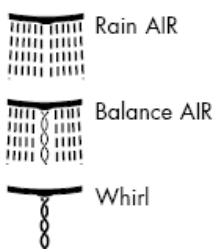
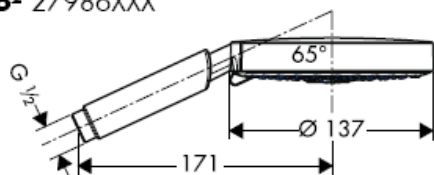

S filtračnou vložkou (A)

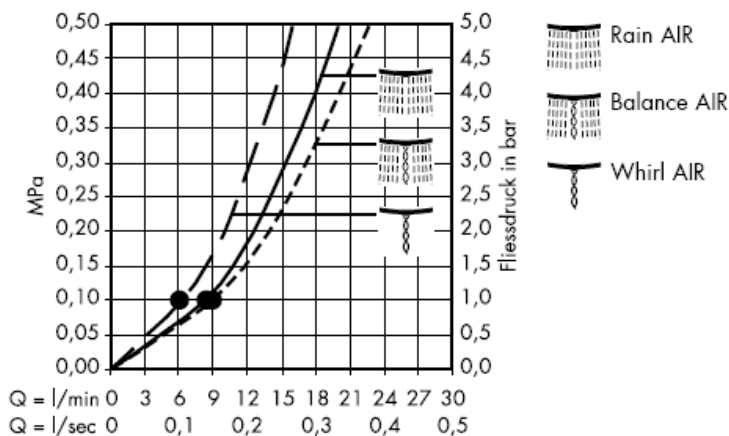

S tesnením so sítkom (B)

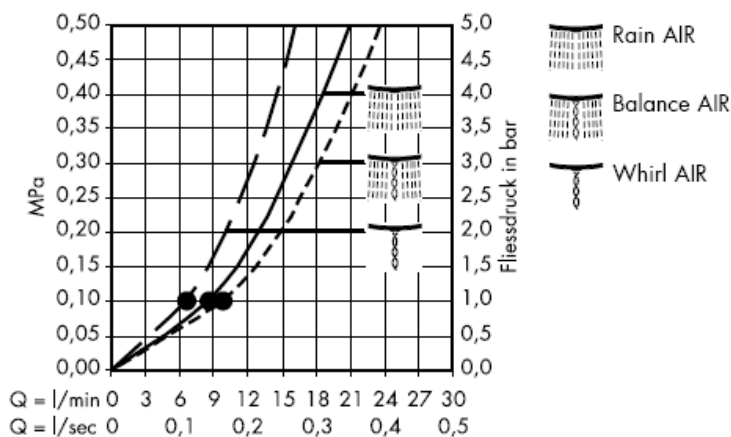

Od • je zaručená funkcia.

Rozmery, pokiaľ možno prispôsobiť rozloženiu obkladov.

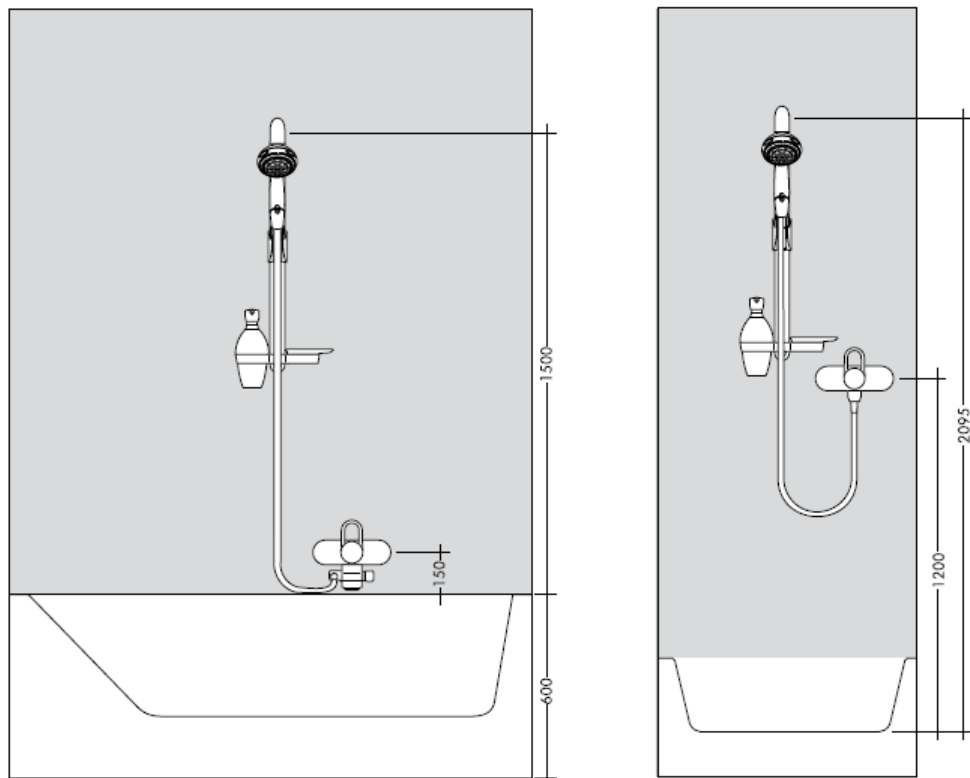

Pri montáži produktu kvalifikovaným odborným personálom je nutné dbať na to, aby upevňovacie plochy boli v celom rozsahu upevnenia rovné (žiadne vyčnievajúce škáry alebo navzájom predsadené obklady), aby konštrukcia steny bola pre montáž produktu vhodná a zvlášť aby v nej neboli žiadne slabé miesta. Priložené vruty a hmoždinky sú vhodné len pre betón. Pri iných konštrukčných materiáloch steny je nutné riadiť sa údajmi výrobcu hmoždiniek.

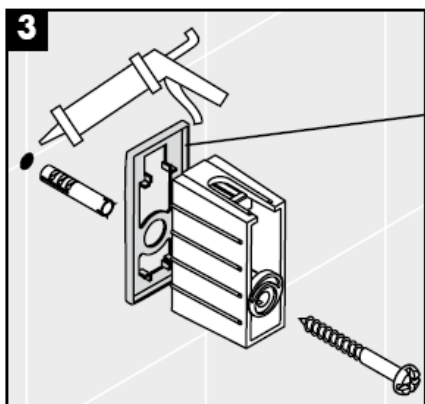
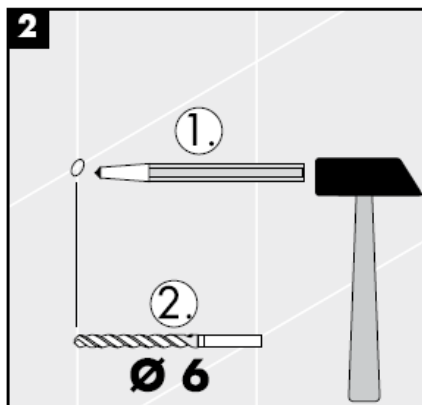
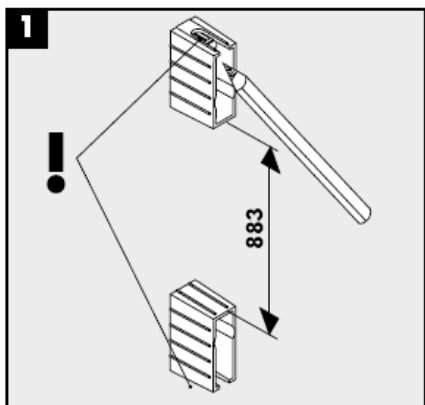

Kružok Decor len u variantu s pochrómovaním alebo pozlátením!

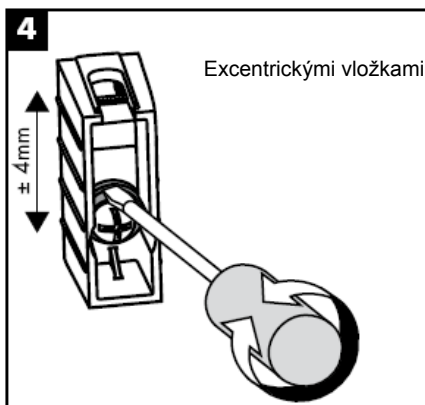

Excentrickými vložkami je možné vyrovnat' toleranciu vŕtaných otvorov.

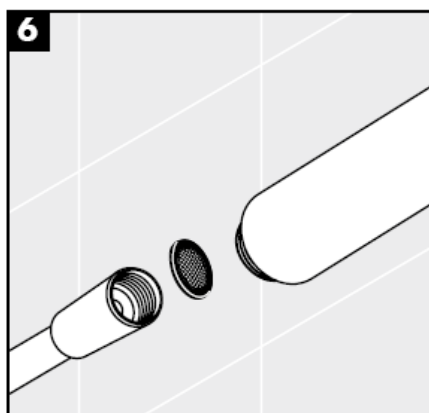
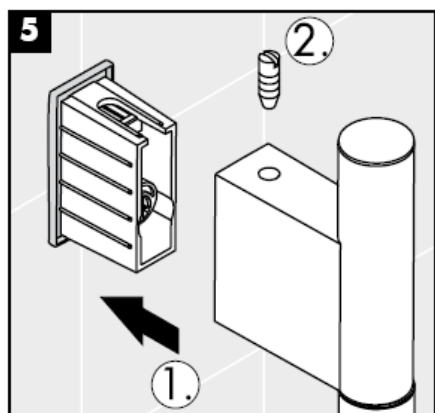

Do prívodu musí byť zabudované so sprchou dodávané sítko, aby zachytilo nečistoty vyplavené z vodovodnej siete. Vyplavené nečistoty môžu ovplyvniť funkciu sprchy, alebo spôsobiť jej poškodenie. Na takto vzniknuté škody sa nevzťahuje záruka firmy Hansgrohe.

Pribalená filtračná vložka (A) sa musí zabudovať, aby zaistila menovitý prietok ručnou sprchou a zabránila prístupu nečistôt vyplavovaných z potrubia.

Pokiaľ sa požaduje vyšší prietok, musí sa vsadiť namiesto filtračnej vložky (A) tesnenie so sitkom (B). Vyplavené nečistoty môžu ovplyvniť funkčnosť alebo môžu viesť aj k poškodeniu funkčných dielov ručnej sprchy. Na tieto škody sa záruka firmy Hansgrohe nevzťahuje.

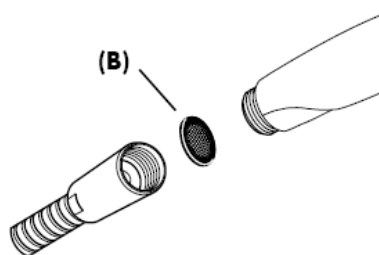
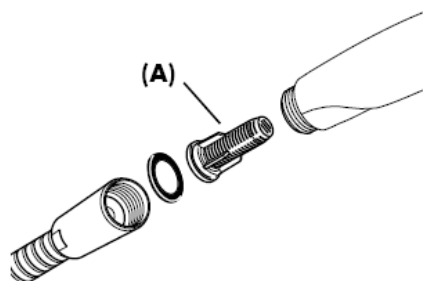

Nastavenie

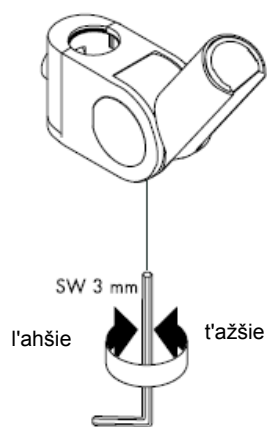
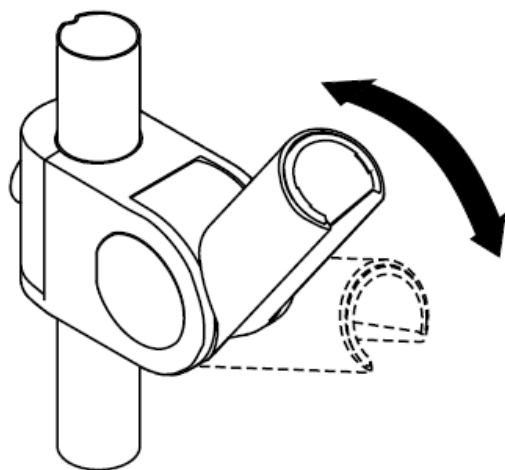
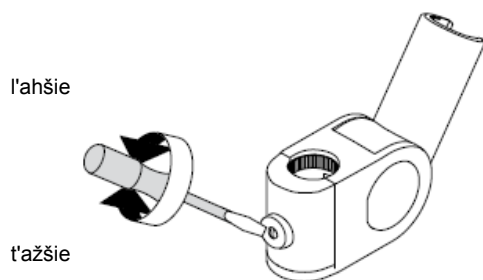
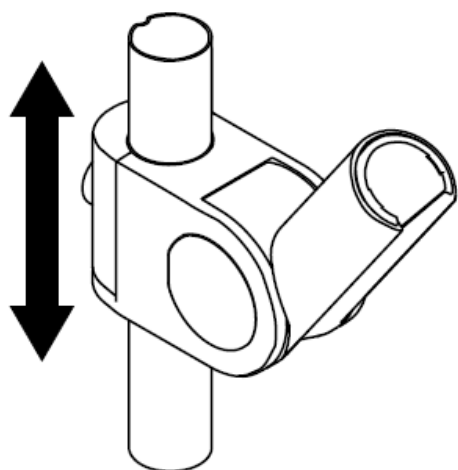

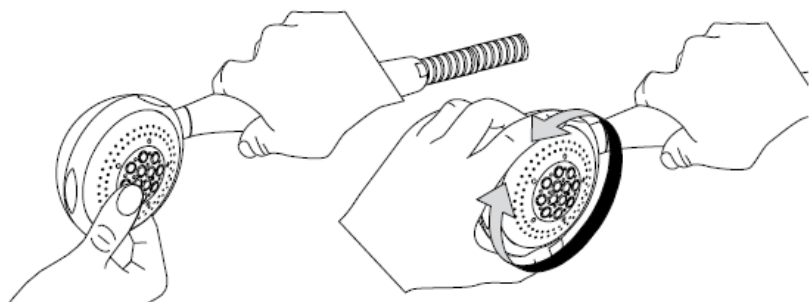

Čistiaca funkcia Rubit, stačí na jednoduché odstránenie vodného kameňa z trysiek kotúča tvarujúceho prúd vody.

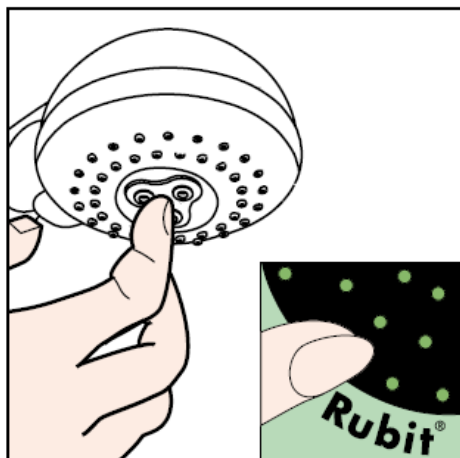

Návod na čistenie

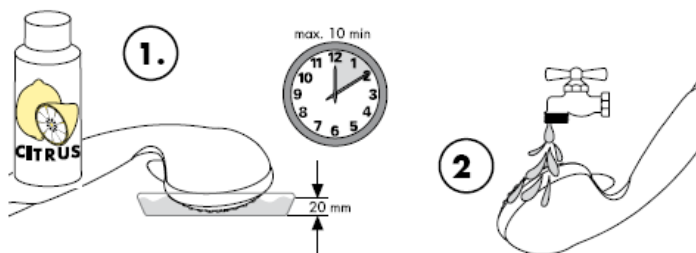

Čištění

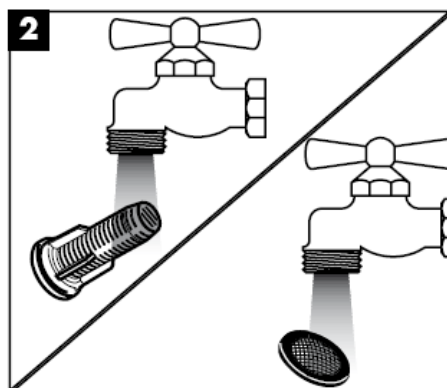
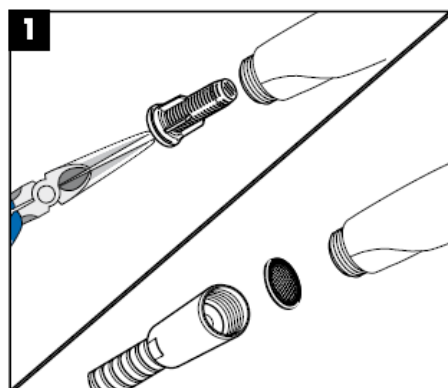
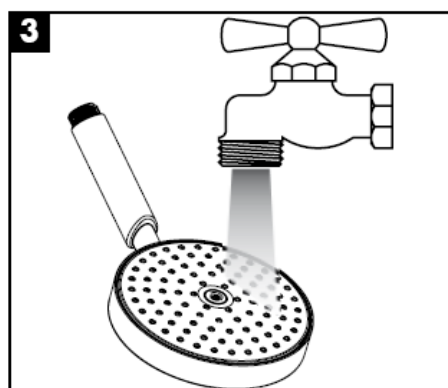
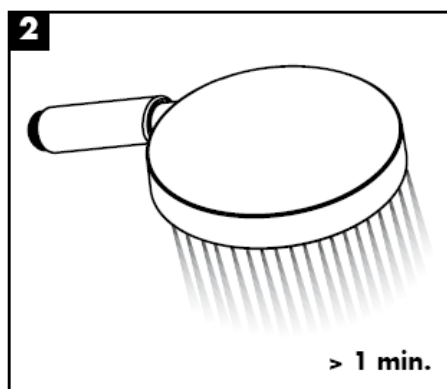
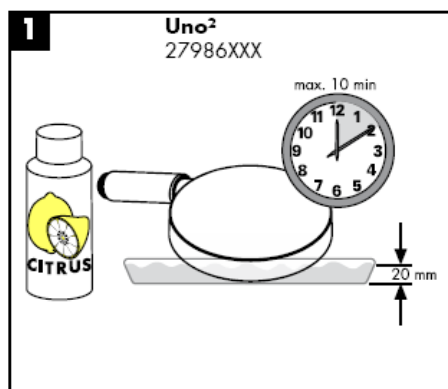

hansgrohe

组装说明

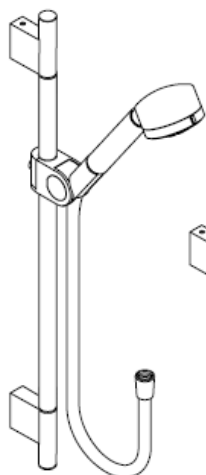

Uno/Arco
27985XXX

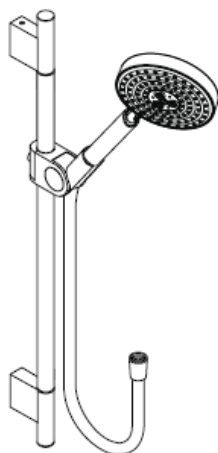

Uno²
27986XXX

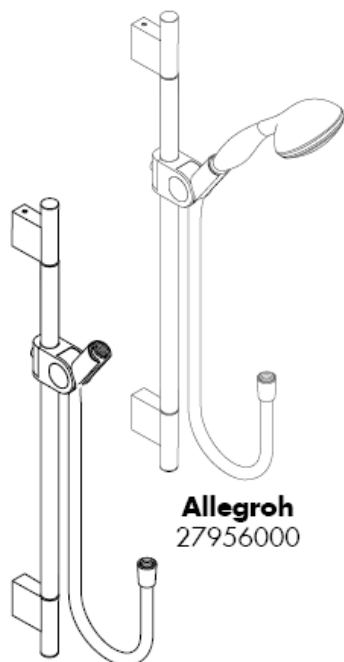

Allegroh
27956000

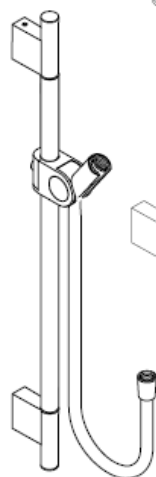

Uno
27989XXX

AXOR®

hansgrohe

Uno/Arco 27985XXX

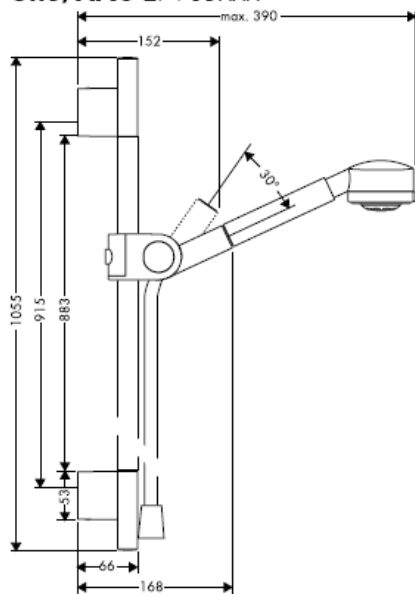

Uno² 27986XXX

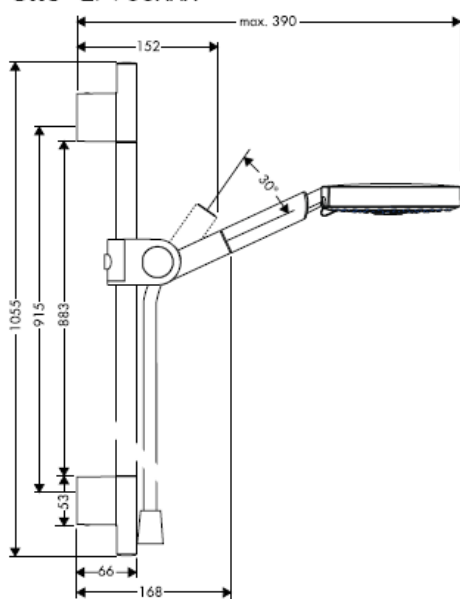

Uno 27989XXX

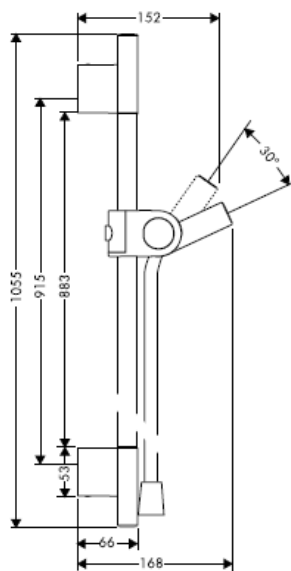

Allegroh 27956000

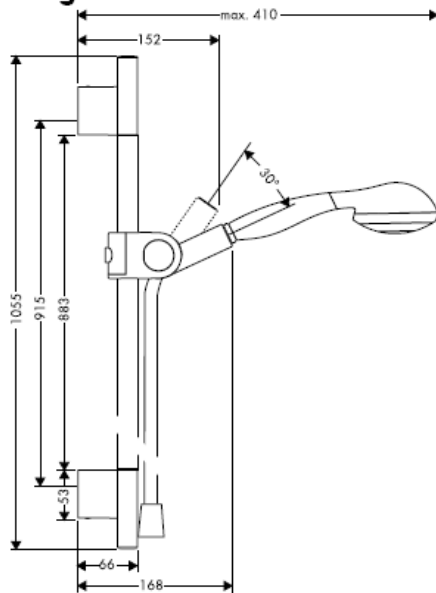



只有与汉斯格雅手提花洒和汉斯格雅淋浴器软管组合使用，方担保最佳的功能。
淋浴软管只适合从淋浴器连接到管接头。切勿在管接头和软管之间安装截止装置。

技术参数

工作压强:	max. 0,6 MPa
推荐工作压强:	0,1 – 0,4 MPa
(1 MPa = 10 bar = 147 PSI)	
热水温度:	max. 60° C

手提花洒适合热输出21
kW、最低流量7升/分钟的连续流热水器。

Uno/Arco 27985XXX

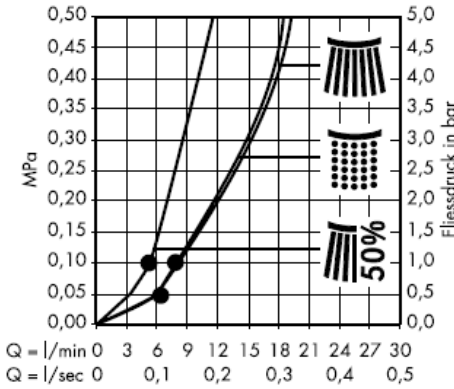
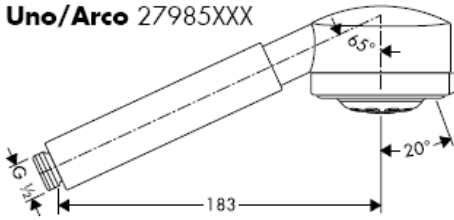

-  普通水流
-  柔和水流
-  按摩喷嘴

Allegroh 27956000

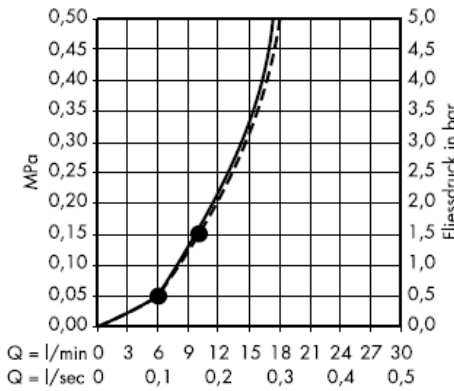
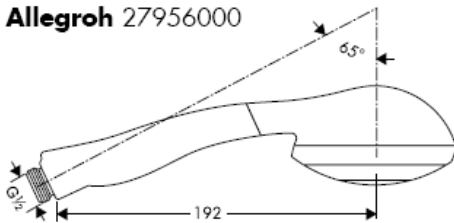

-  普通水流
-  柔和水流

Uno² 27986XXX

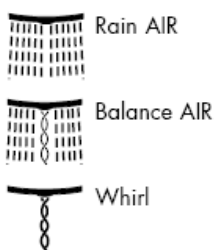
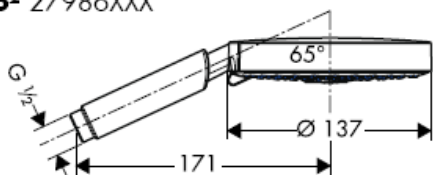

带滤柱 (A)

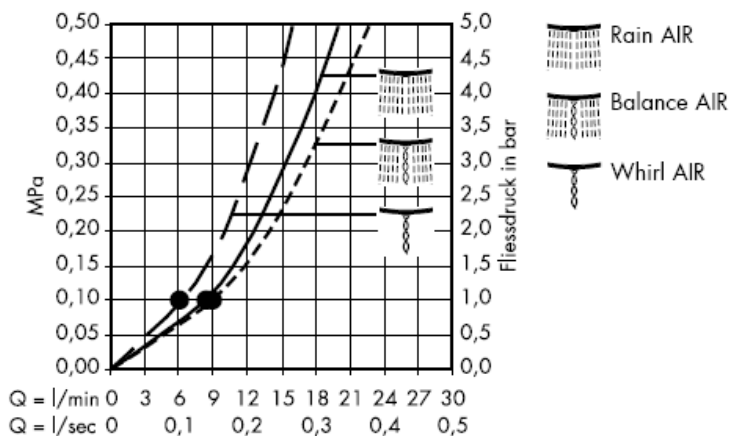

带滤网 (B)

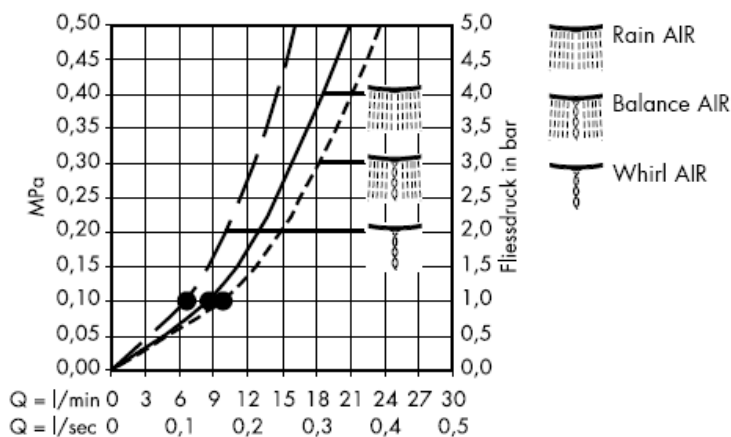

从•开始, 正常功能得以保证。

如果可能，可根据瓷砖方格调整尺寸。

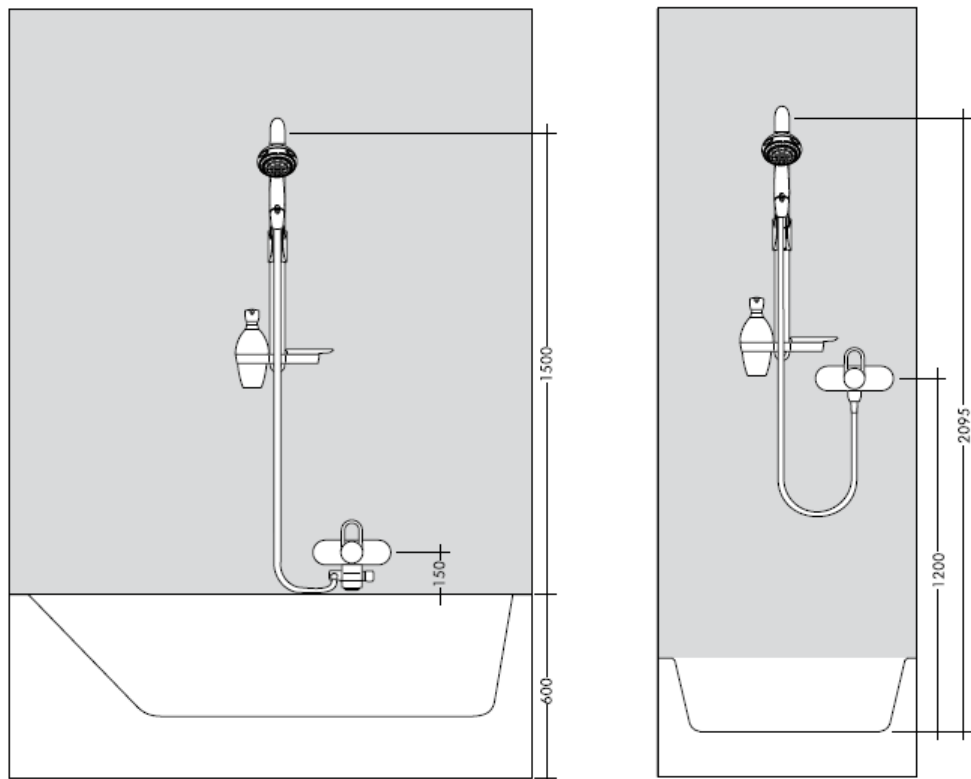

在安装产品的位置，安装人员必须确保安装面的墙面是平的（没有突出物或瓷砖没有突起），墙体结构适合产品的安装并没有弱点。包装内的膨胀螺丝只适用于混凝土墙体。对于其他墙体结构必须咨询膨胀螺丝生产商的建议。

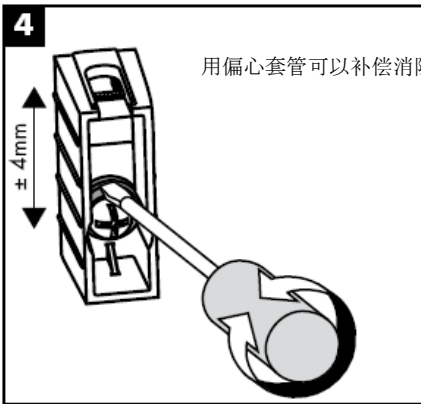
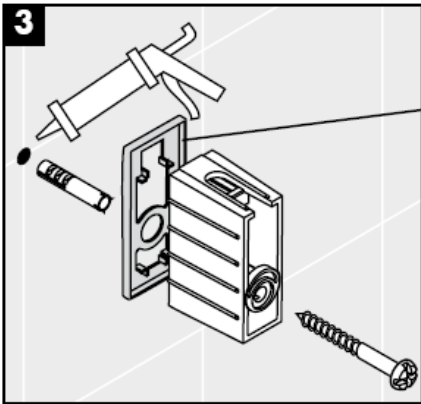
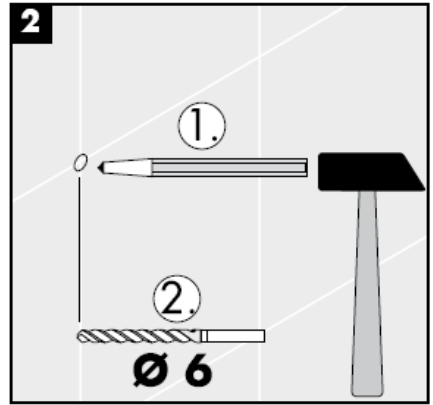
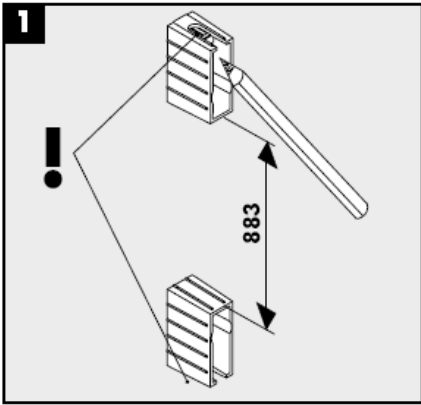

用偏心套管可以补偿消除钻孔的偏差。

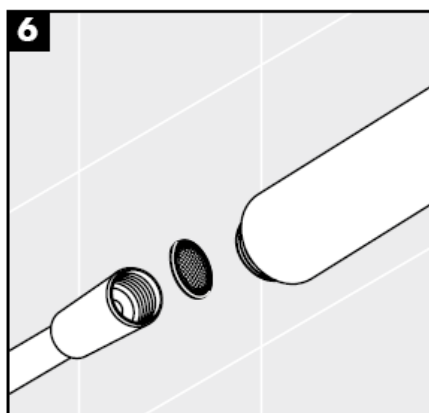
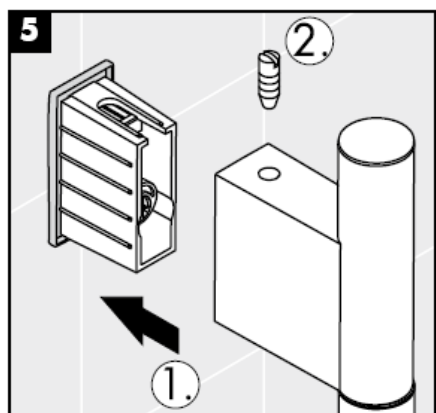

必须装上花洒所附带的滤网密封垫，以过滤管道里的杂质污物。杂质污物会影响花洒的功能和/或损坏花洒的功能部件，由此而产生的产品损坏不属于汉斯格雅的保修范围。

为了防止管道中的脏东西冲入花洒内，与手持花洒包装在一起的滤柱 (A) 必须安装。如果想要更大的出水量，可用滤网 (B) 代替滤柱 (A)。

这些脏东西会影响手持花洒的功能或损坏手持花洒的功能部件，由此引起的损失汉斯格雅公司概不负责。

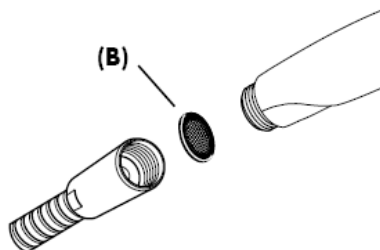
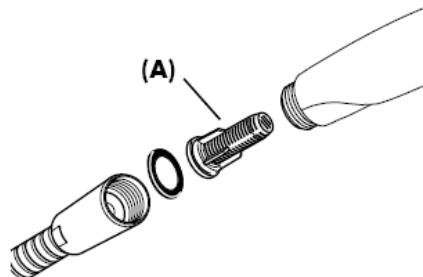

校准

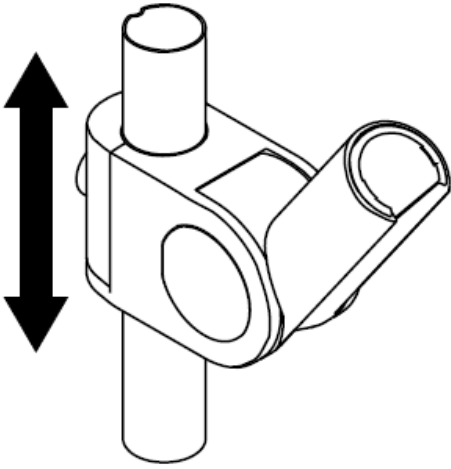

更加简单

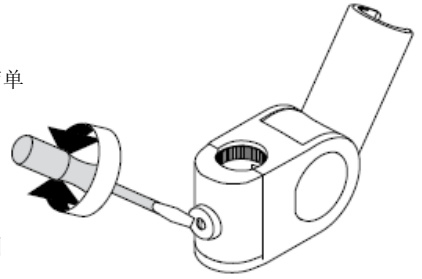

更坚固

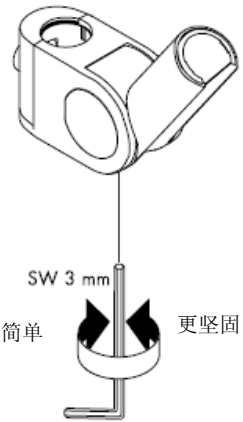
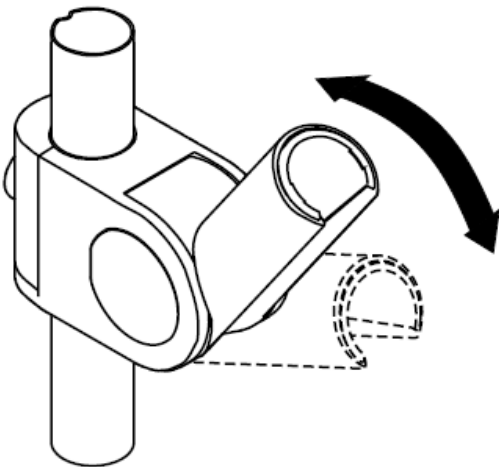

更加简单

更坚固

清洗

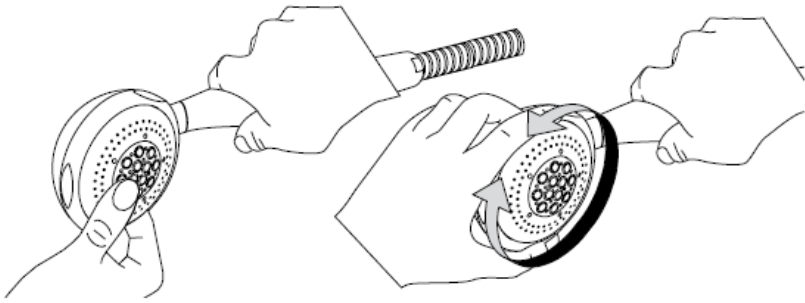

有了Rubit®, 手工清洁功能, 要去掉喷头上的水垢, 只需简单地搓除即可。

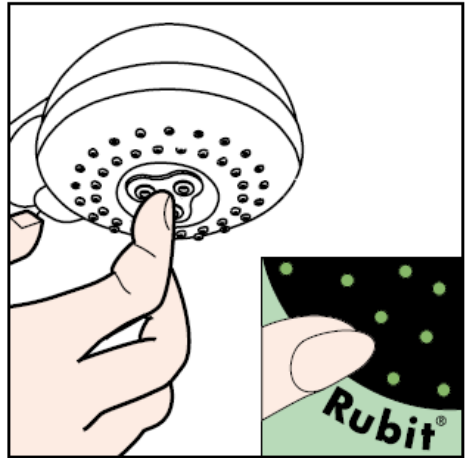

清洗说明

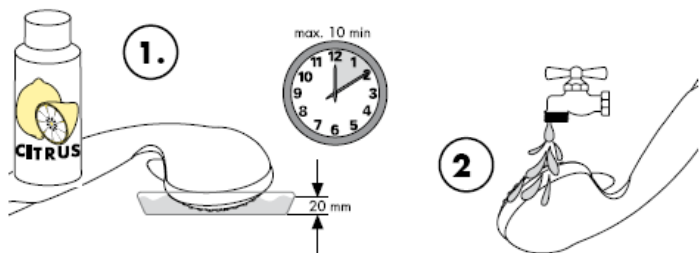

清洗

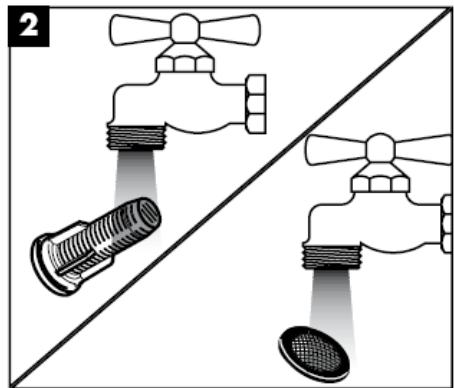
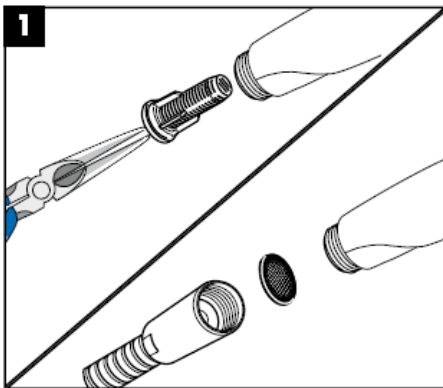
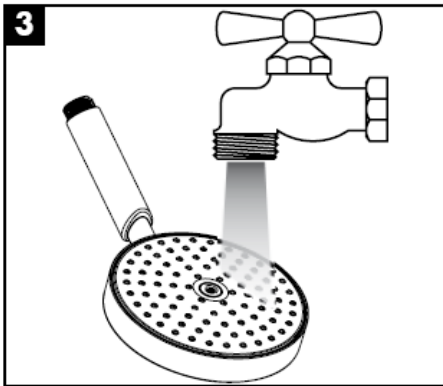
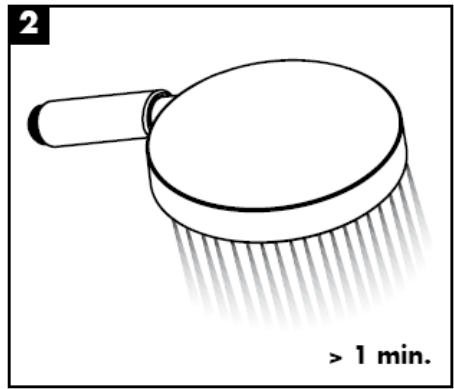
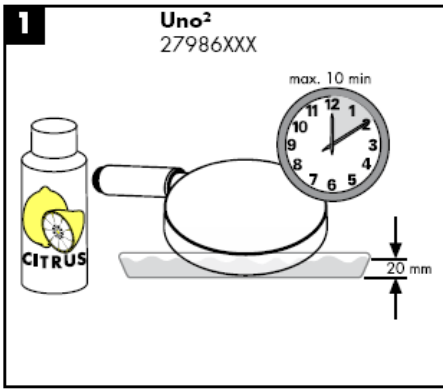

hansgrohe

Инструкция по монтажу

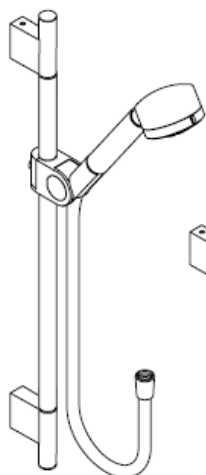

Uno/Arco
27985XXX

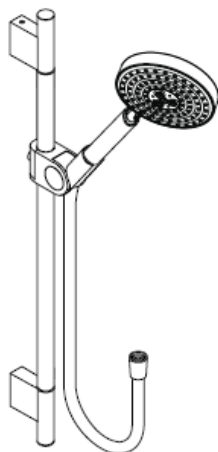

Uno²
27986XXX

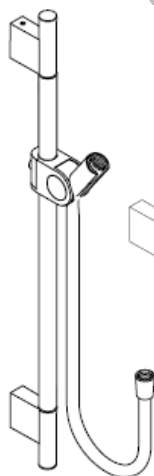

Uno
27989XXX

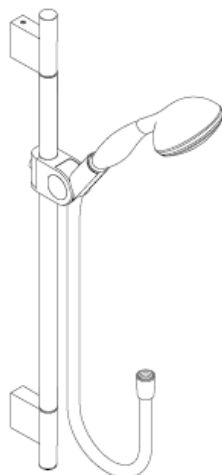

Allegroh
27956000

AXOR®

hansgrohe

Uno/Arco 27985XXX

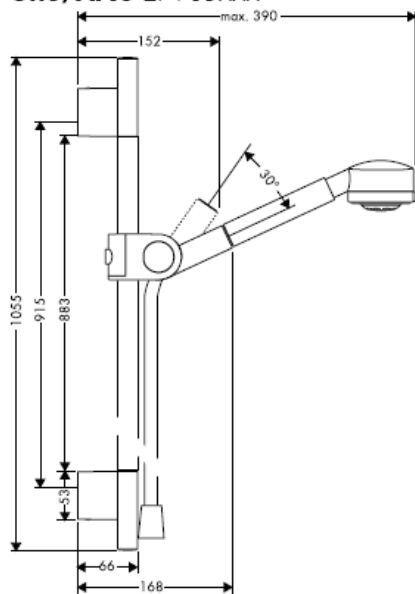

Uno² 27986XXX

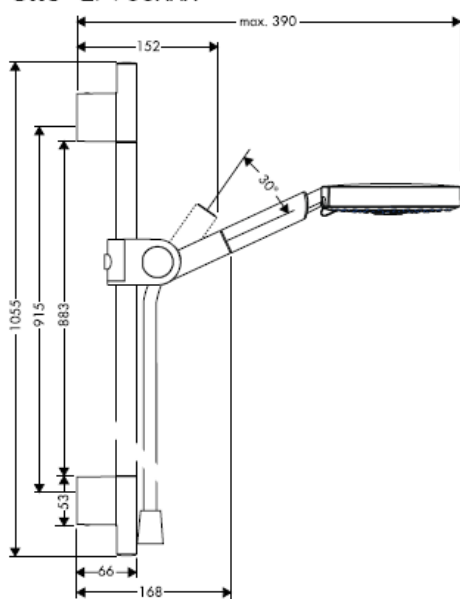

Uno 27989XXX

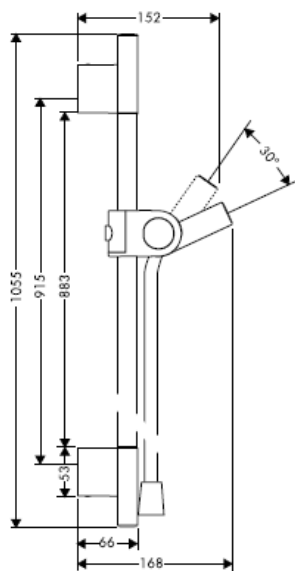

Allegroh 27956000

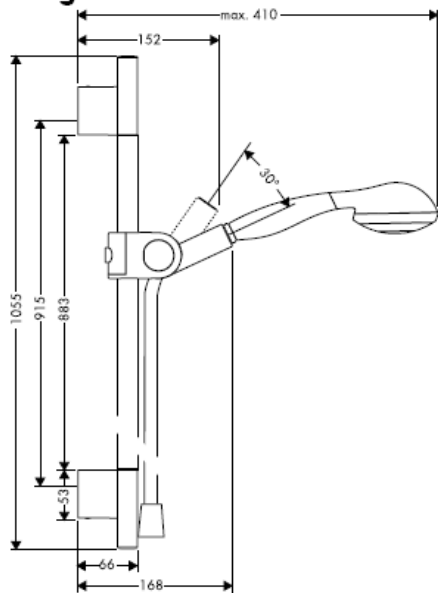



Оптимальное функционирование гарантируется только при использовании в комбинации с ручными душами Hansgrohe и душевыми шлангами Hansgrohe. Душевые шланги подходят только для подсоединения души к арматуре. Не устанавливайте дополнительных затворов между шлангом и арматурой!

Технические данные

Рабочее давление: max. 0,6 МПа
Рекомендуемое рабочее давление: 0,1 – 0,4 МПа
(1 МПа = 10 bar = 147 PSI)
Температура горячей воды: max. 60° C

Ручной душ может использоваться с проточными водонагревателями мощностью от 21кВ и напором воды не менее 7 л/мин.

Uno/Arco 27985XXX

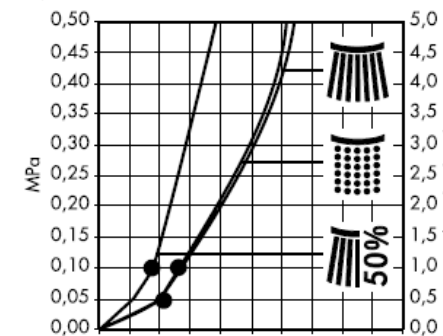
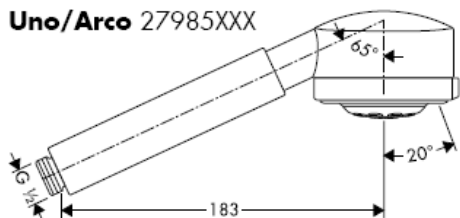

Q = l/min 0 3 6 9 12 15 18 21 24 27 30
 Q = l/sec 0 0,1 0,2 0,3 0,4 0,5



Нормальная струя



Мягкая струя



Экономный режим

Allegroh 27956000

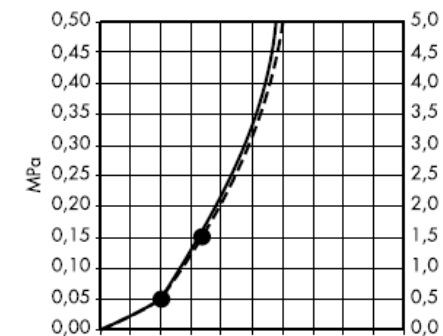
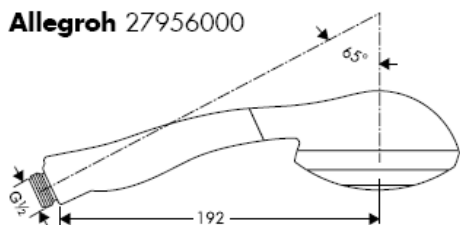

Q = l/min 0 3 6 9 12 15 18 21 24 27 30
 Q = l/sec 0 0,1 0,2 0,3 0,4 0,5



Нормальная струя



Мягкая струя

Uno² 27986XXX

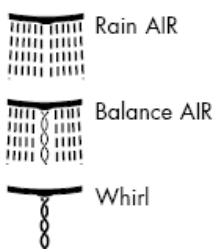
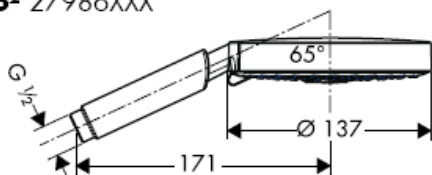

С фильтрующей вставкой
(A)

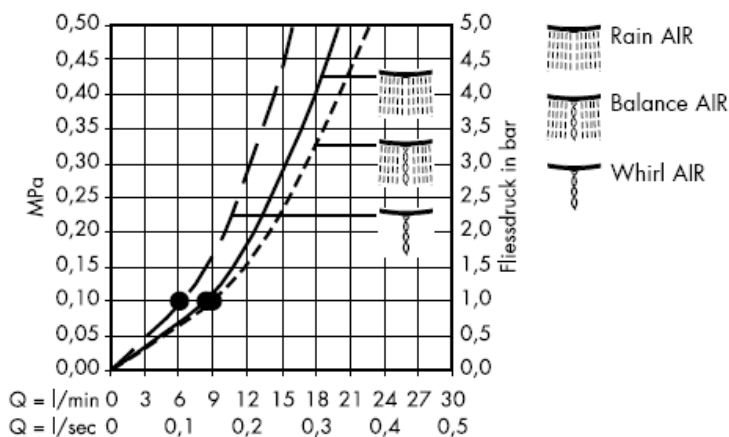

С фильтром-сеткой,
содержится в упаковке.

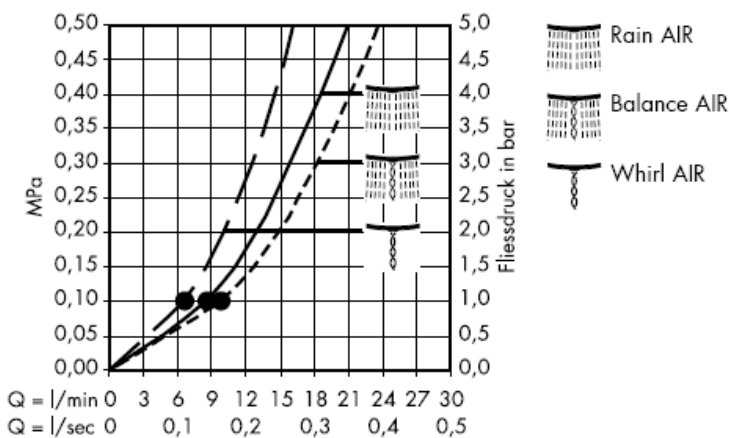

Гарантированное функционирование при показателях свыше *.

При определении внешних размеров при монтаже старайтесь по возможности учитывать расположение кафельной плитки.

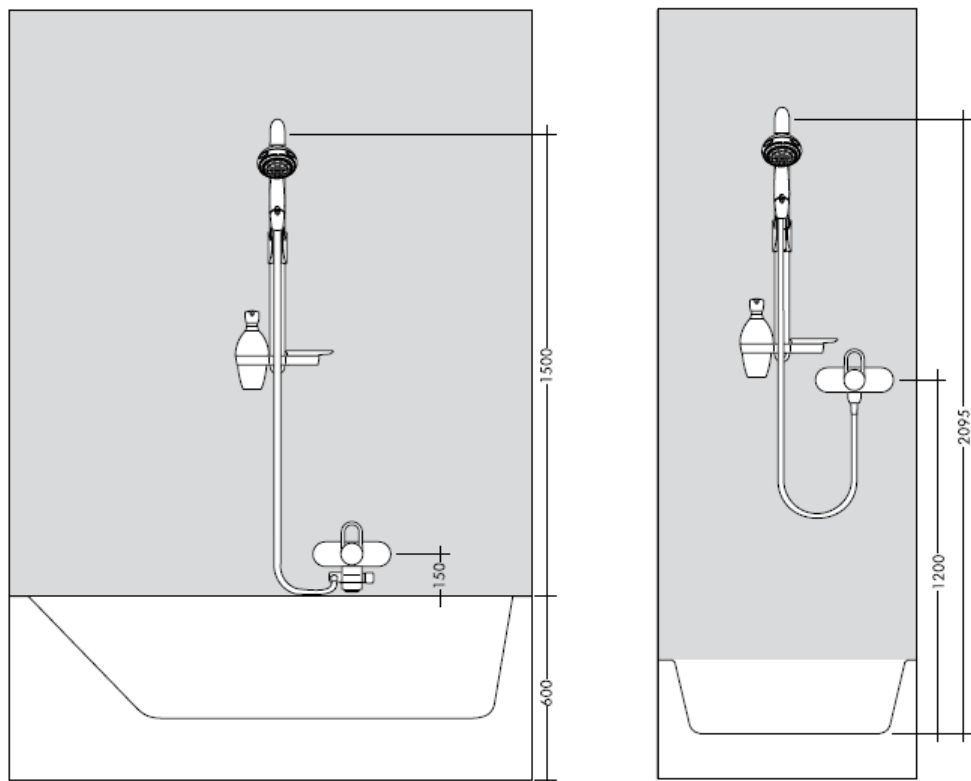

При монтаже изделия квалифицированным персоналом необходимо следить за тем, чтобы, поверхность крепления была плоской во всей зоне крепления (без выступающих швов или смещения плитки), структура стен подходила для монтажа изделия и, в частности, не имела слабых мест. Прилагаемые винты и дюбели предназначены только для бетона. При других типах стен необходимо соблюдать указания производителей дюбелей.

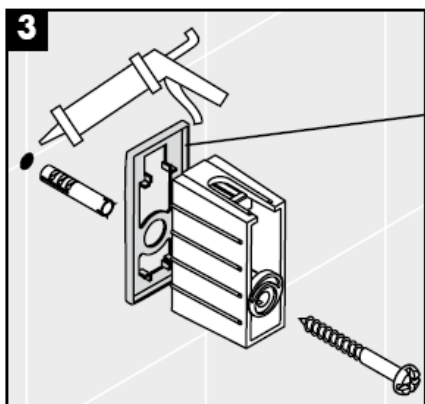
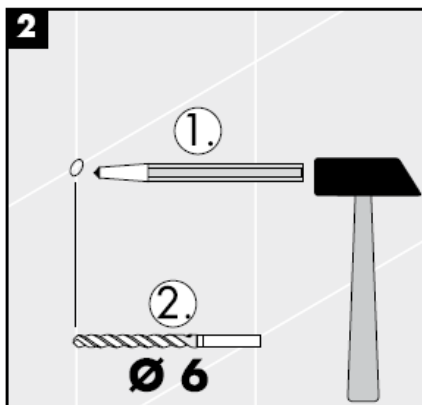
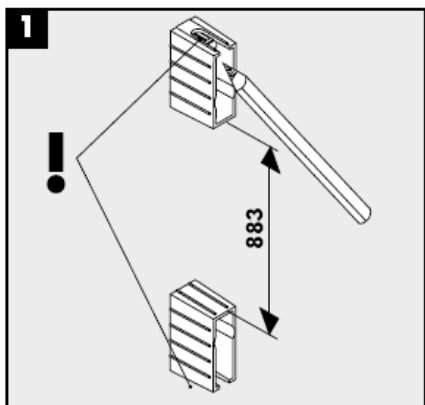

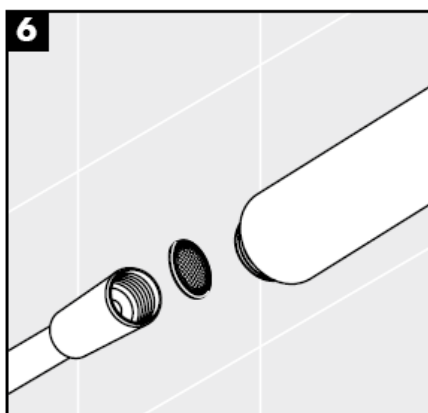
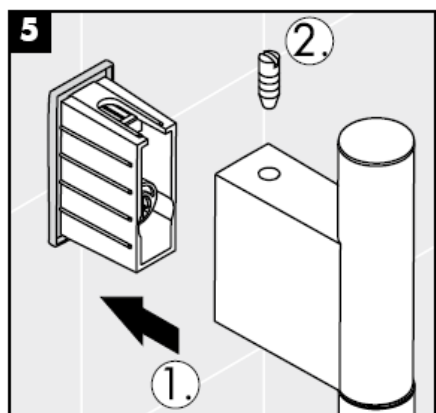

Для предотвращения попадания частиц грязи из водопроводной сети необходимо установить фильтр, прилагаемый к ручному душу. Частицы грязи могут нарушить отдельные функции и/или привести к повреждению функциональных деталей ручного душа, Hansgrohe не несет ответственность за повреждения вследствие отсутствия фильтра.

Предустановленный фильтр (А) предназначен для обеспечения стандартного расхода воды и защиты внутренней части лейки ручного душа от содержащихся в водопроводной воде загрязнений. Если Вы желаете повысить расход воды, Вам необходимо заменить предустановленный фильтр (А) на фильтр-сеточку (В).

Содержащиеся в воде загрязнения могут попасть внутрь лейки привести к повреждениям/поломке внутреннего механизма лейки.

В этом случае покупатель теряет право на гарантию.

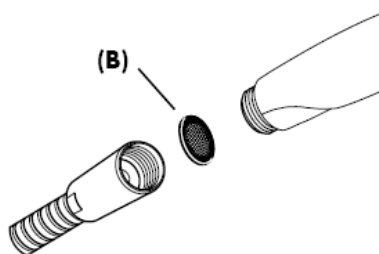
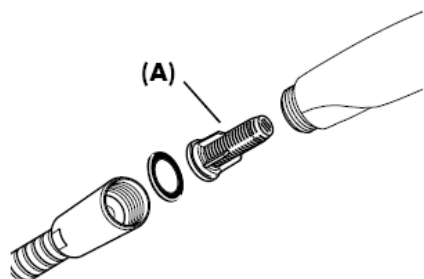

Настройка

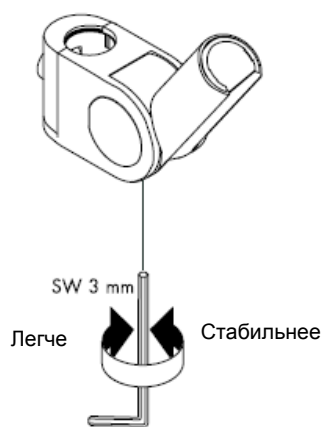
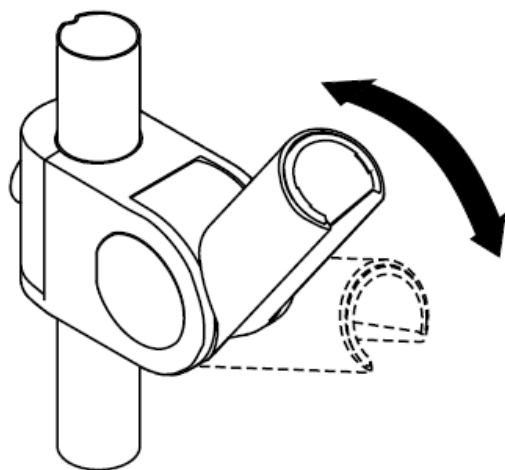
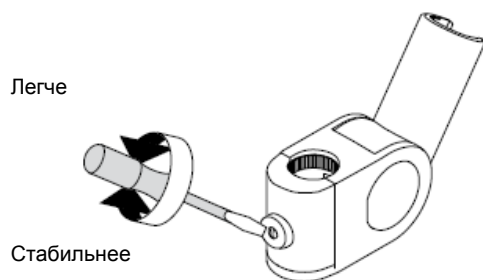
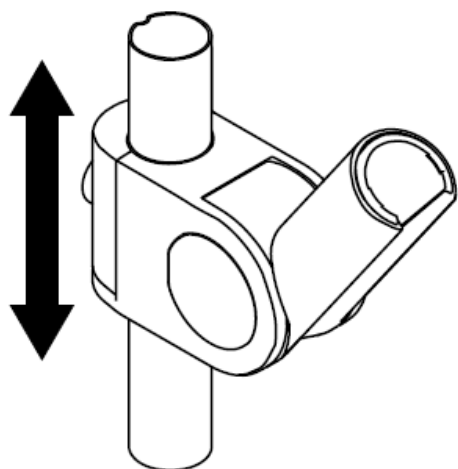

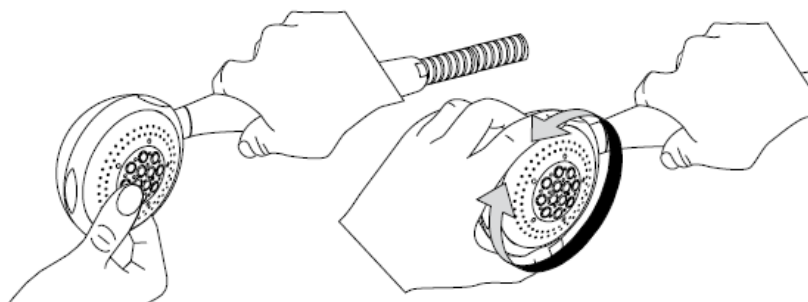

система Rubit® позволяет удалять известковые отложения, достаточно провести по эластичной поверхности аэратора пальцем, как известковые отложения будут удалены.



Руководство по уходу за изделием

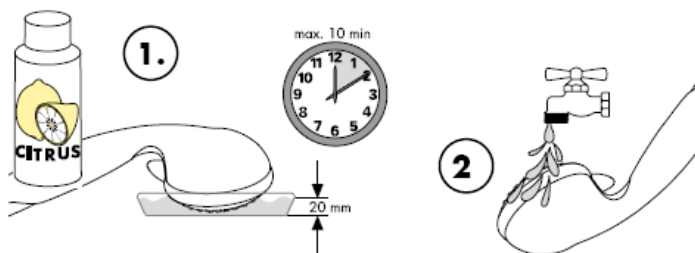

Очистка

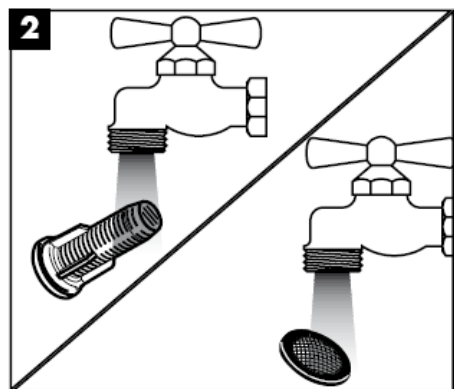
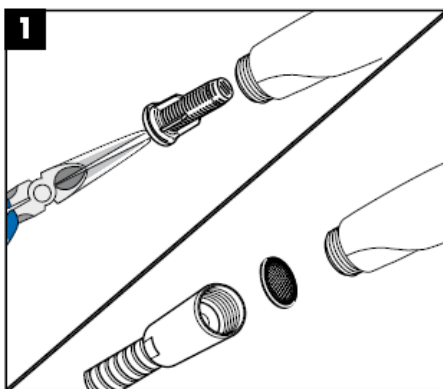
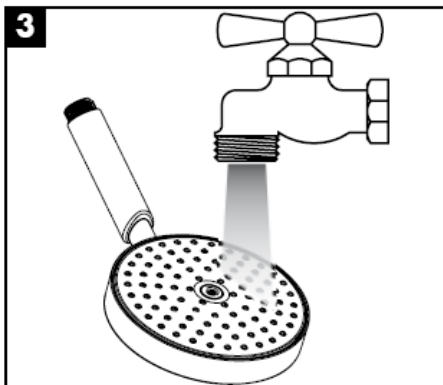
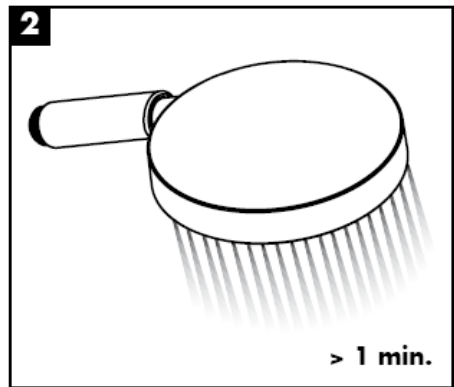
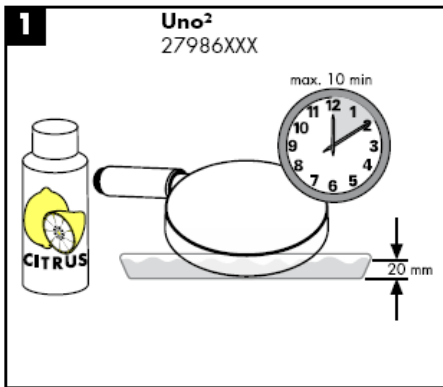

hansgrohe

Szerelési útmutató

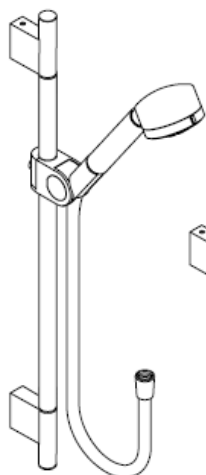

Uno/Arco
27985XXX

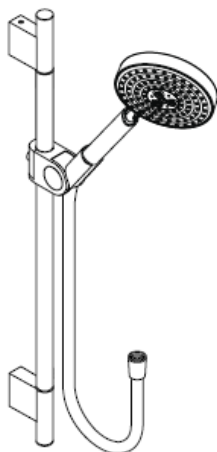

Uno²
27986XXX

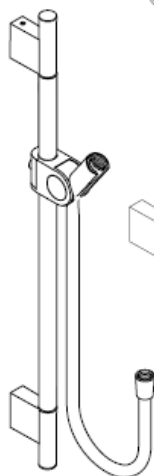

Uno
27989XXX

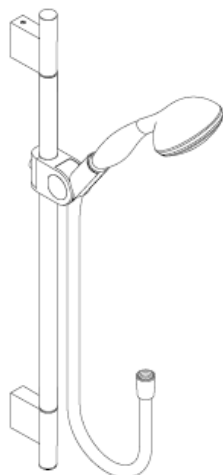

Allegroh
27956000

AXOR®

hansgrohe

Uno/Arco 27985XXX

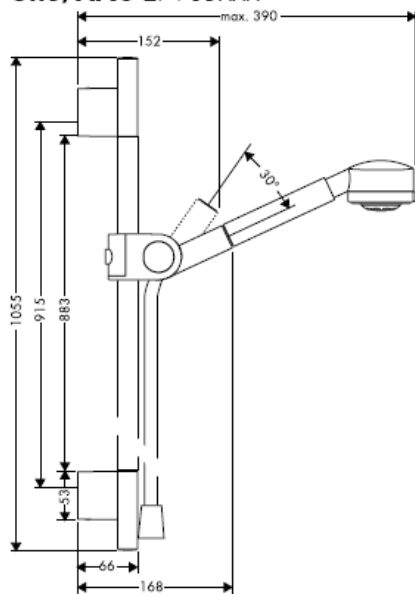

Uno² 27986XXX

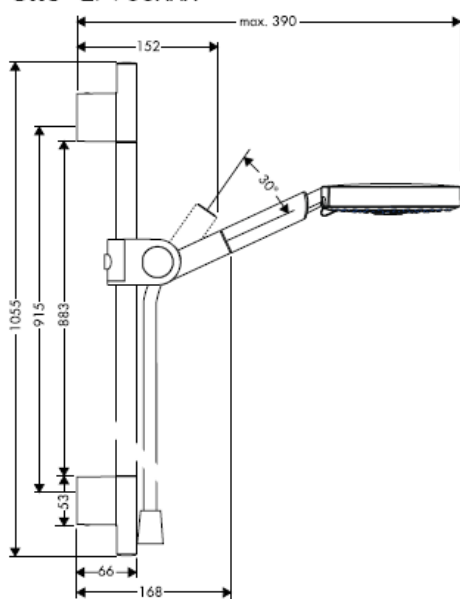

Uno 27989XXX

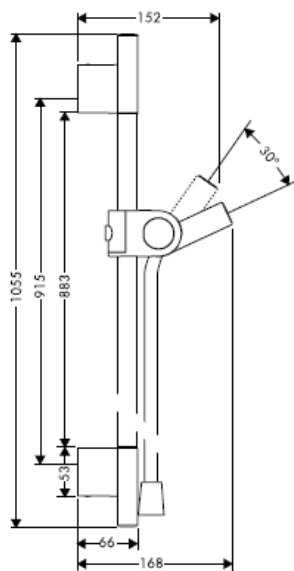

Allegroh 27956000

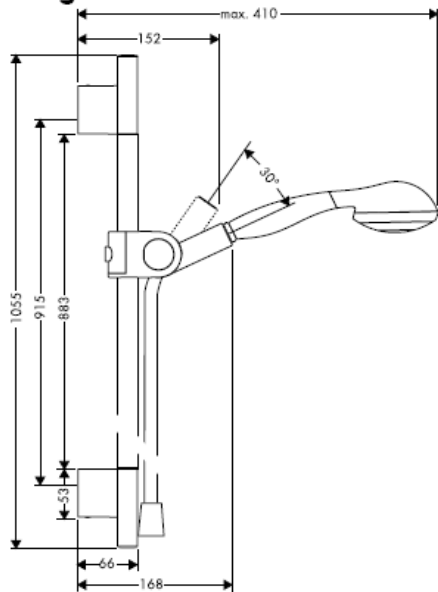



A megfelelő működést csak Hansgrohe kézzuhanyokkal és Hansgrohe zuhanycsővekkel garantáljuk. A zuhanycsővek kizárólag zuhanyok csaptelepekkel való összekötésére alkalmasak. A zuhanycső után (folyásirány szerint) elzárás beszerelése nem engedélyezett!

Műszaki adatok

Üzemi nyomás:	max. 0,6 MPa
Ajánlott üzemi nyomás: (1 MPa = 10 bar = 147 PSI)	0,1 – 0,4 MPa
Forróvíz hőmérséklet:	max. 60° C

A kézzuhany átfolyós vízmelegítővel való használatra 21 kW-os teljesítménytől és 7l/perc minimális átfolyástól alkalmas.

Uno/Arco 27985XXX

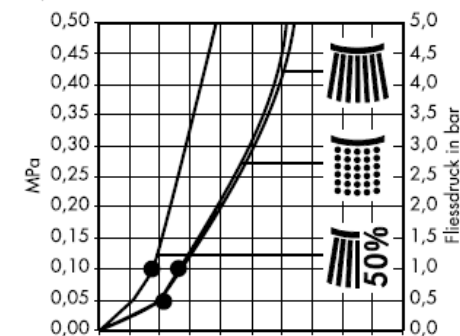
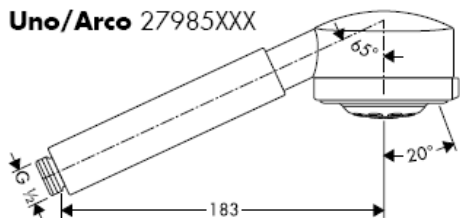

Normálsugár



Lágysugár



Takarékos sugár

Allegroh 27956000

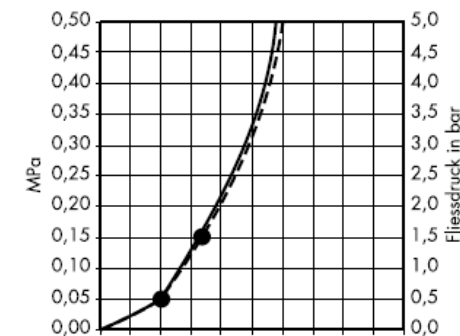
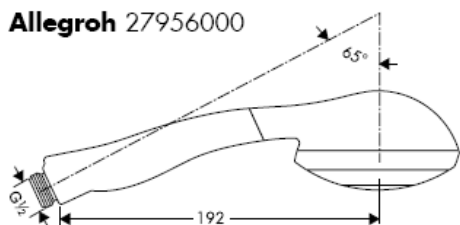

Normálsugár



Lágysugár

Uno² 27986XXX

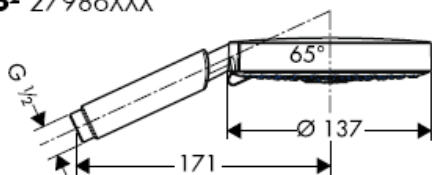

Rain AIR



Balance AIR



Whirl



Szűrőbetéttel (A)

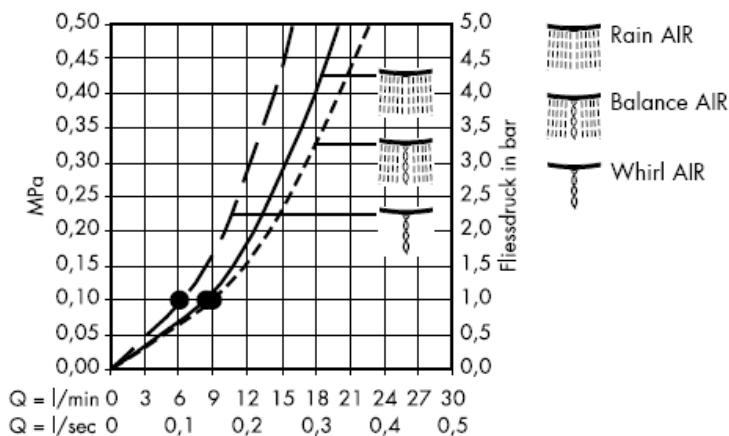

Szűrőtömítéssel (B)

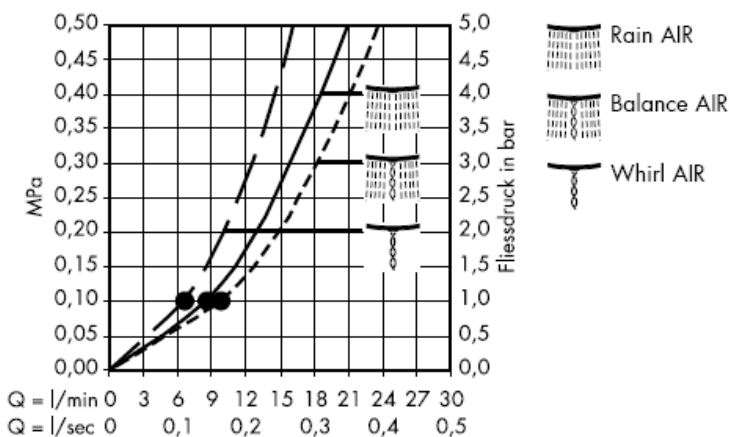

A • -től működik az adott funkció.

A méretet a lehetőségekhez mérten igazítsuk a csempe elrendezéséhez.

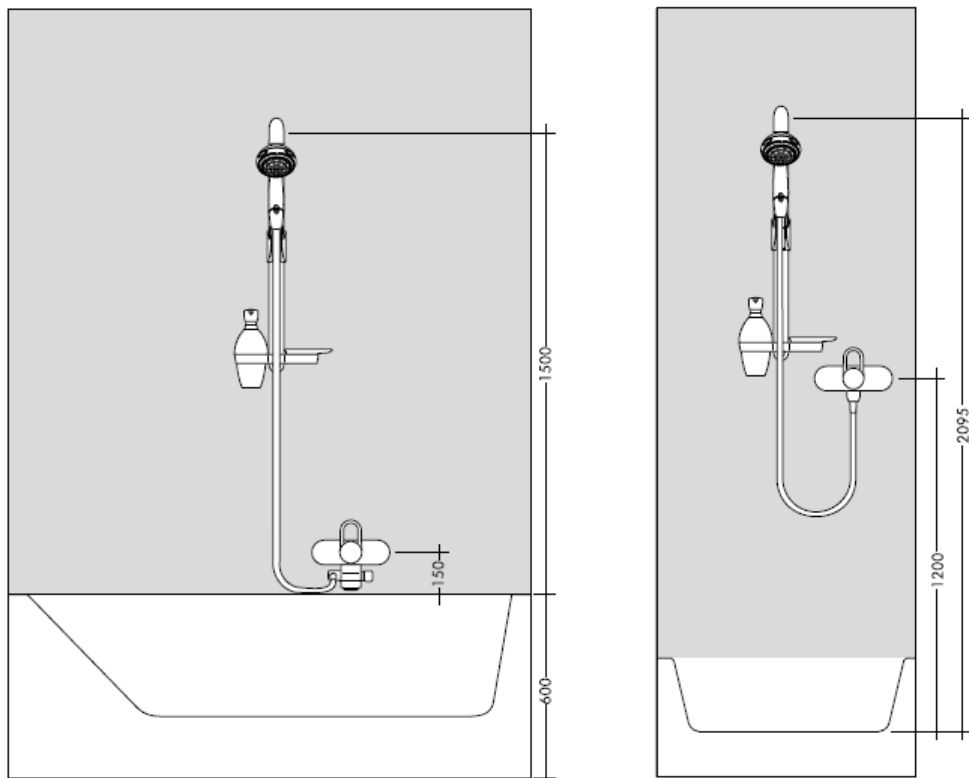

Miközben szakképzett szakember végzi a termék felszerelését, ügyelni kell arra, hogy a rögzítési felületek a rögzítési terület teljes egészén síkok (nincsenek kiálló fugák vagy csempeszélek), a fal felépítése alkalmas a termék felszereléséhez, és különösképpen, hogy nincsenek benne gyenge pontok. A mellékelt csavarok és dübelek csak betonhoz alkalmasak. Egyéb falazatoknál figyelembe kell venni a dübelgyártó gyártói utasításait.

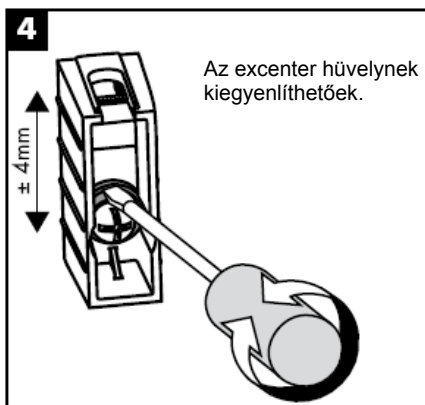
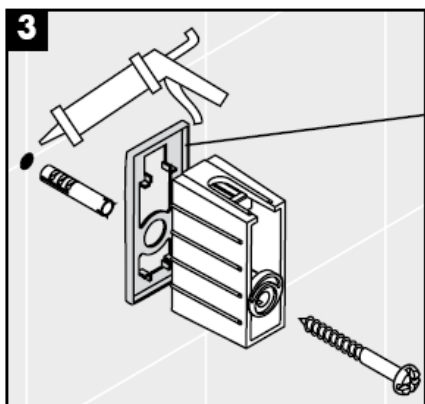
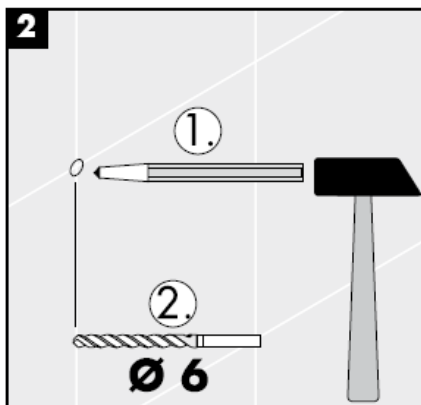
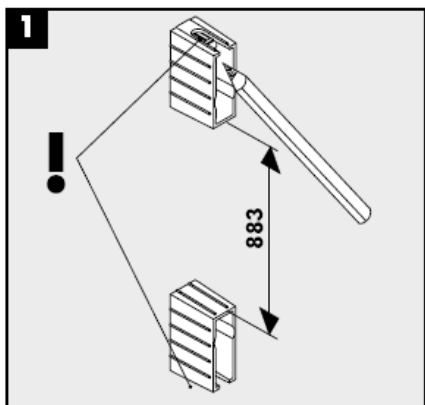

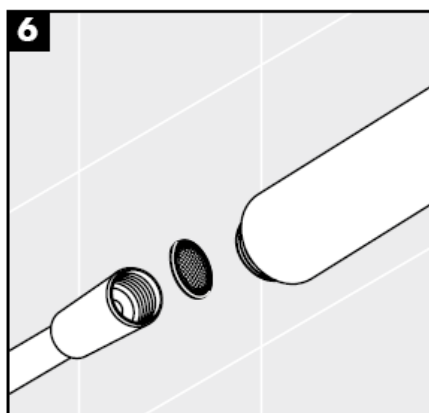
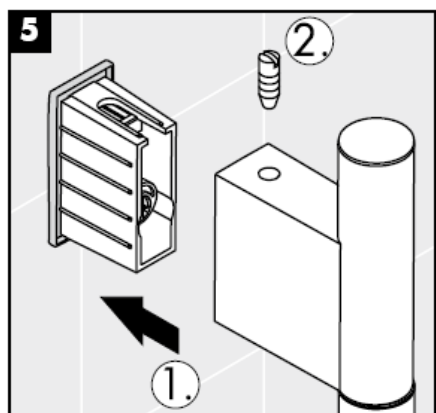

A kézi zuhanyhoz csomagolt szűrőtömítést be kell szerelni a vízhálózatból származó szennyeződések kiküszöbölésére. A beáramló szennyeződések akadályozhatják és / vagy teljesen tönkre is tehetik a zuhany funkcióit. Az ezekből adódó károkért a Hansgrohe nem felel.

A mellékelt szűrőbetétet (A) be kell szerelni, hogy elérjük a kézizuhany norma szerinti átfolyását, valamint, hogy elkerüljük a vezetékes hálózattól származó szennyeződések zuhanyba való bekerülését. Amennyiben nagyobb átfolyási vízmennyiséget szeretnénk elérni, a szűrőbetét (A) helyett használjuk a szűrőtömítést (B). A vezetékes hálózattól bekerülő szennyeződések gátolhatják a termék működését, és/vagy megromlíthatják a zuhany működő alkatrészeit. Az ebből adódó károkért a Hansgrohe nem felel.

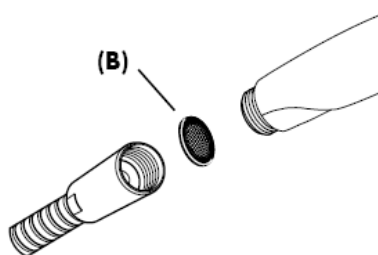
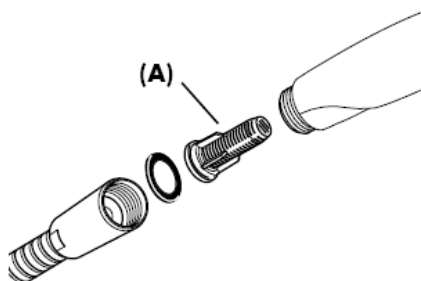

Beszereles

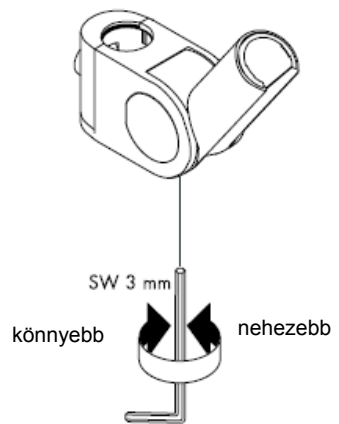
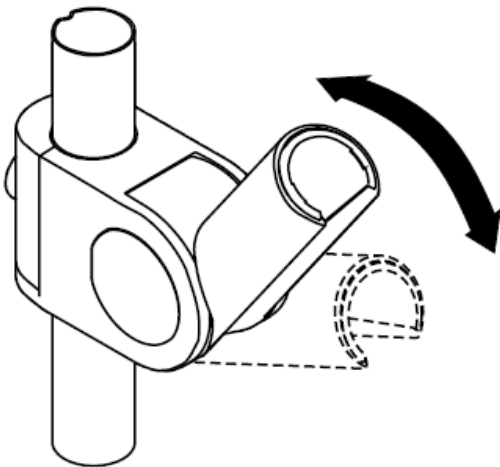
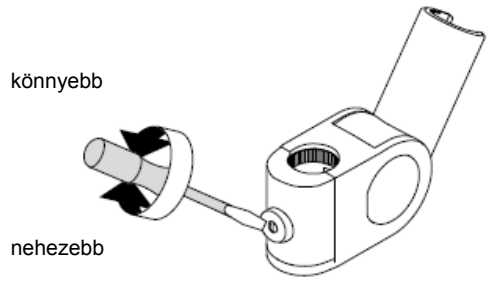
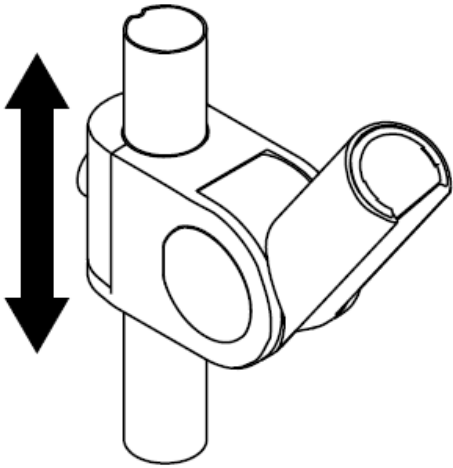

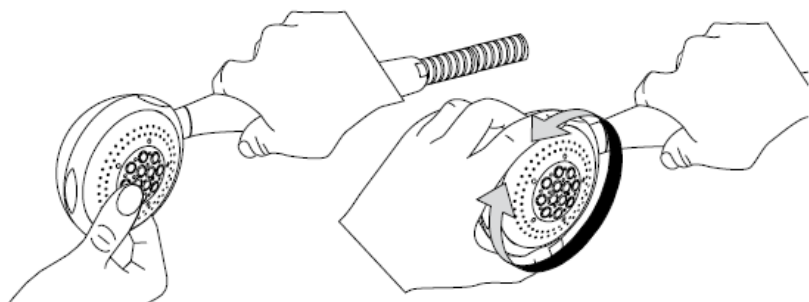

A Rubit® manuális tisztítófunkciónak köszönhetően a vízszugáryílások egyszerű ledörzsöléssel megtisztíthatók a vízkőtől.

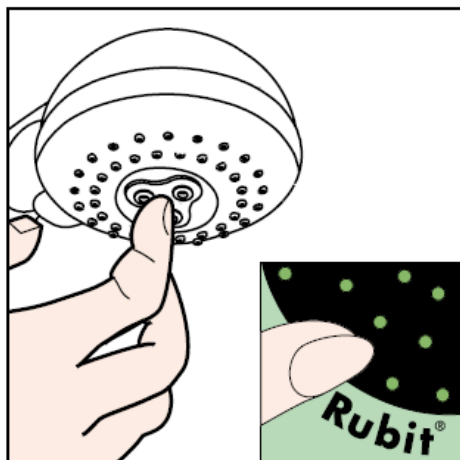

Ápolási tanácsok

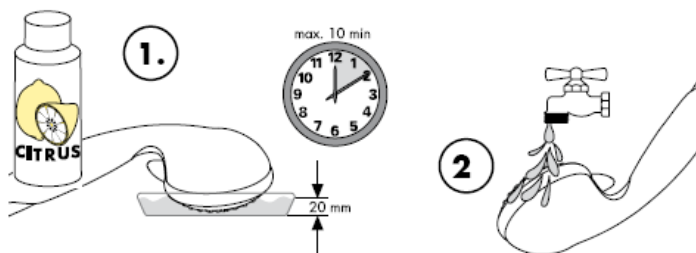

Tisztítás

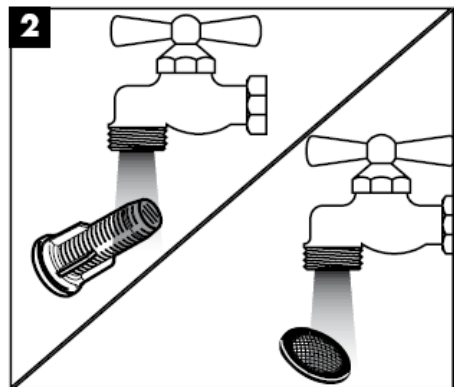
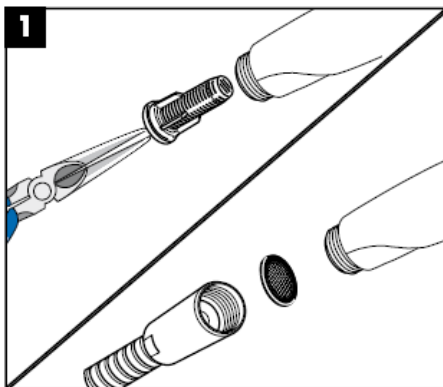
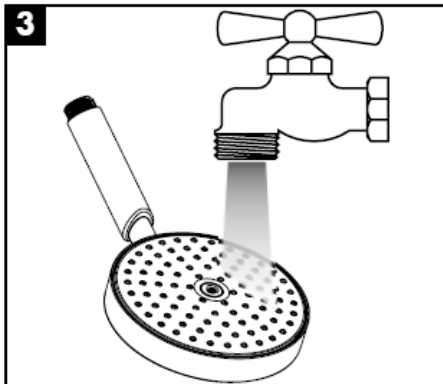
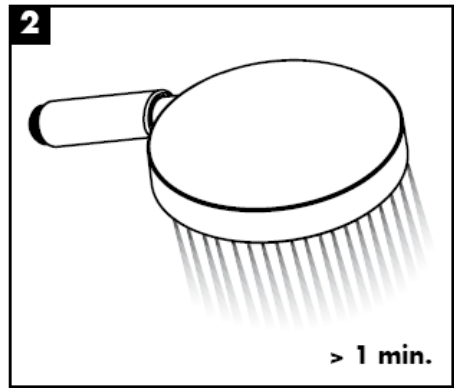
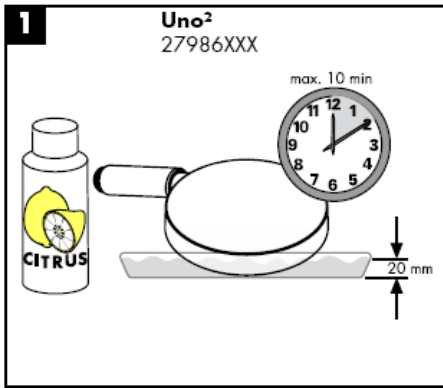

hansgrohe

Asennusohje

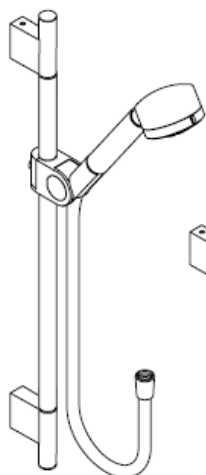

Uno/Arco
27985XXX

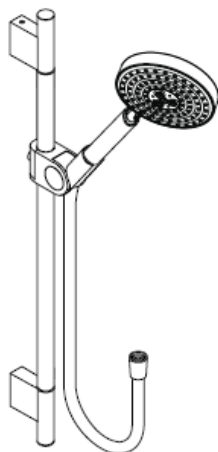

Uno²
27986XXX

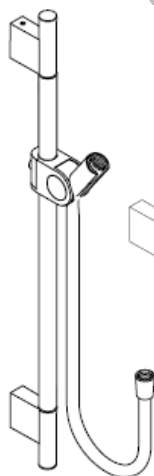

Uno
27989XXX

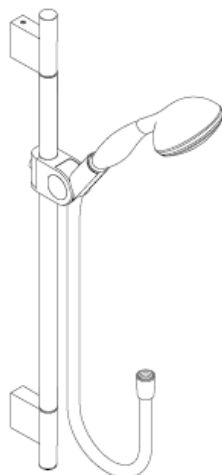

Allegroh
27956000

AXOR®

hansgrohe

Uno/Arco 27985XXX

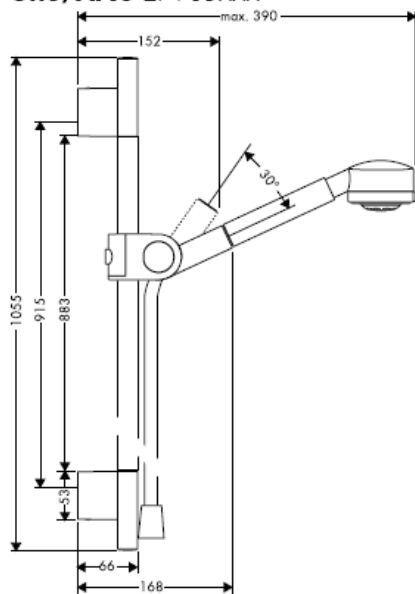

Uno² 27986XXX

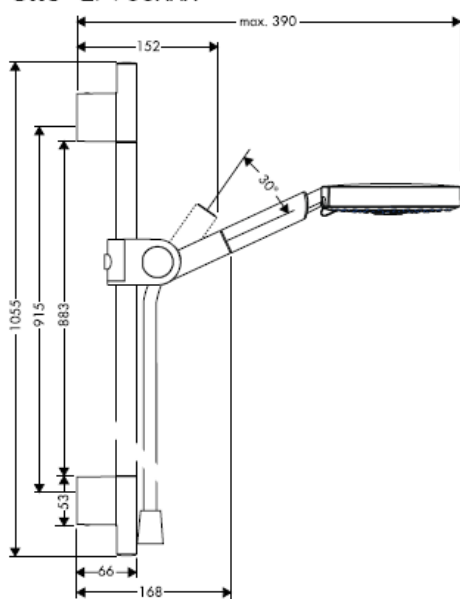

Uno 27989XXX

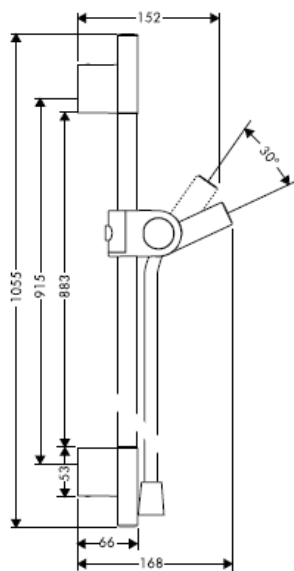

Allegroh 27956000

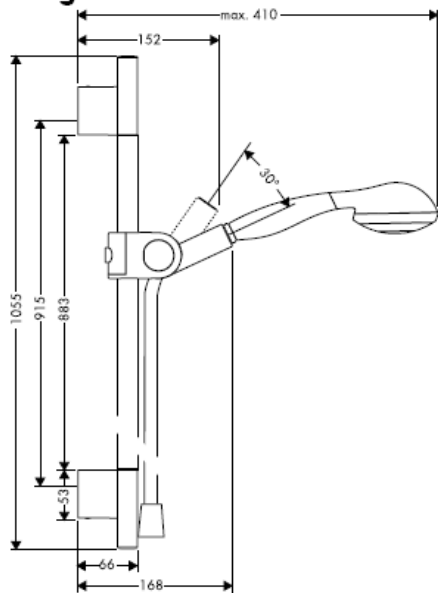



Optimaalinen toiminta on taattuna vain Hansgrohe käsisuihkuja ja Hansgrohe suihkuletkuja käytettäessä. Suihkuletkut soveltuvat vain käsisuihkun liittämiseen armatuureihin. Letkun jälkeen virtaussuunnassa oleva sulkuventtiili ei ole sallittua!

Tekniset tiedot

Käyttöpaine:	max. 0,6 MPa
Suosittelut käyttöpaine: (1 MPa = 10 bar = 147 PSI)	0,1 – 0,4 MPa
Kuuman veden lämpötila:	max. 60° C

Käsisuihku soveltuu käytettäväksi sellaisen läpivirtauskuumentimen yhteydessä, jonka teho on vähintään 21 kW ja läpivirtausmäärä vähintään 7 l/min.

Uno/Arco 27985XXX

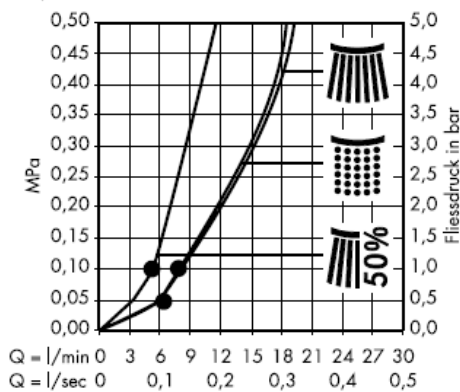
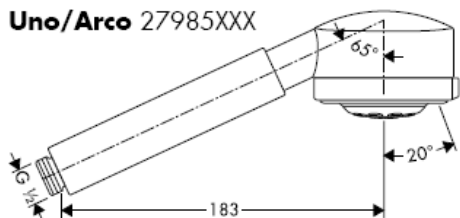

Normaalisuihku



Pehmosuihku



Ecostrahl-vedensäästö

Allegroh 27956000

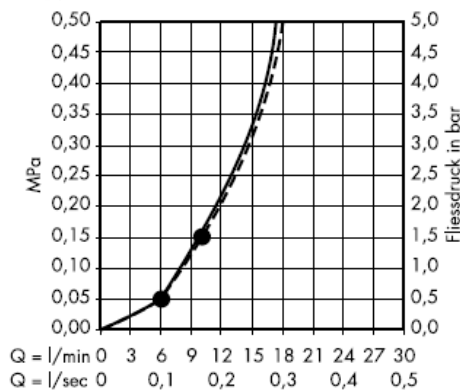
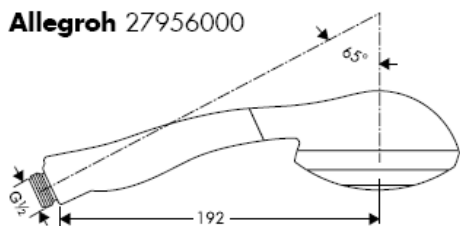

Normaalisuihku



Pehmosuihku

Uno² 27986XXX

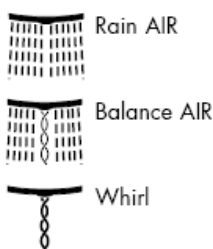
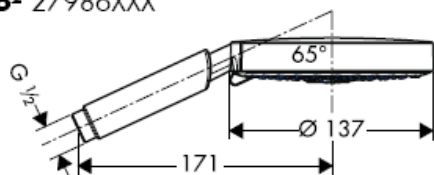

Suodatinpanoksella (A)

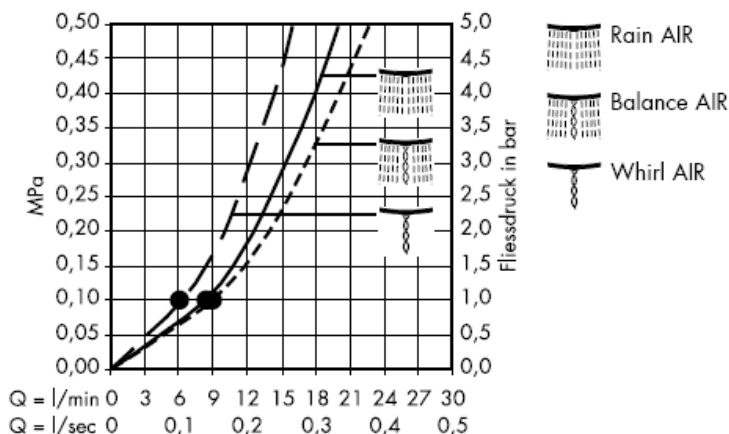

Sihtitiivisteellä (B)

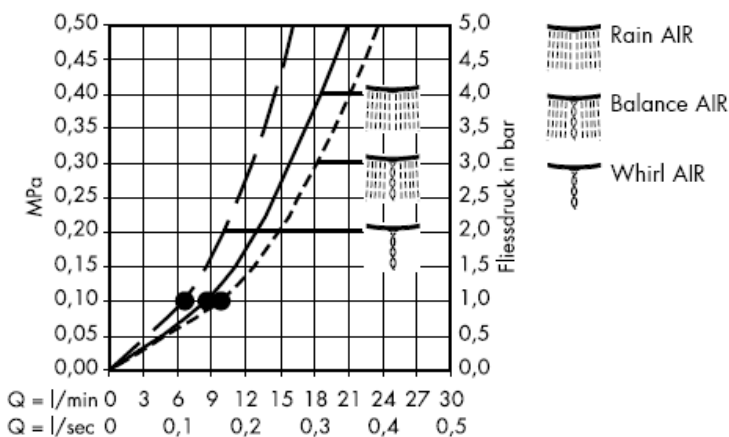

Tämä toiminta on taattuna • alkaen.

Sovita mitat mahdollisuuksien mukaan laattaruudukon mukaisiksi.

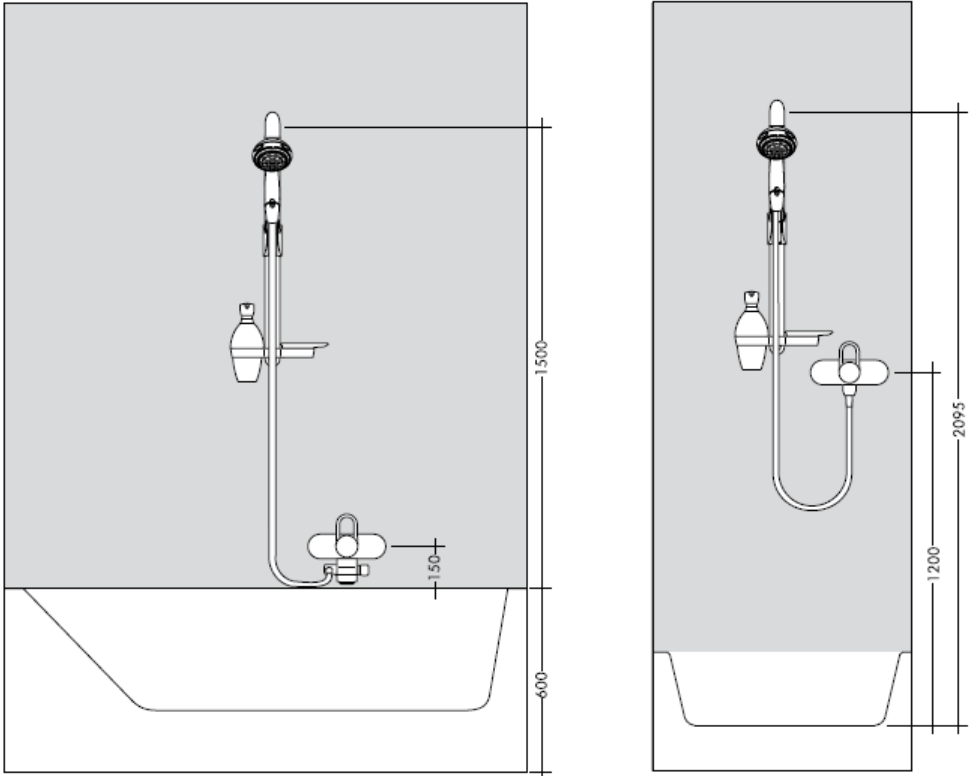

Kun pätevä ammattihenkilöstö suorittaa tuotteen asennusta, on huomioitava, että kiinnityspinta on koko kiinnityksen alueella tasainen (ei ulkonevia saumoja tai laattojen tasomuutoksia) ja, että seinän rakenne soveltuu tuotteen asentamiseen eikä siinä ole heikkoja kohtia. Mukana olevat kiinnitysruuvit ja kiinnitysankkurit soveltuvat betoniin kiinnittämiseen. Kiinnitettäessä tuotetta muihin seinärakenteisiin, noutata kiinnittimien valmistajan ohjeita.

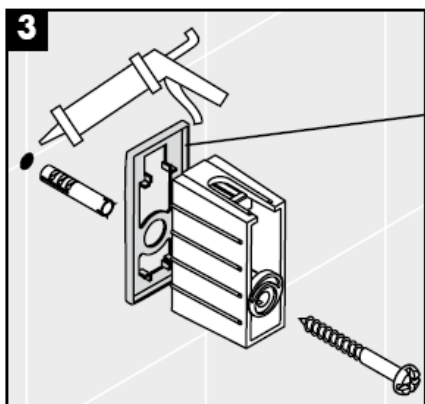
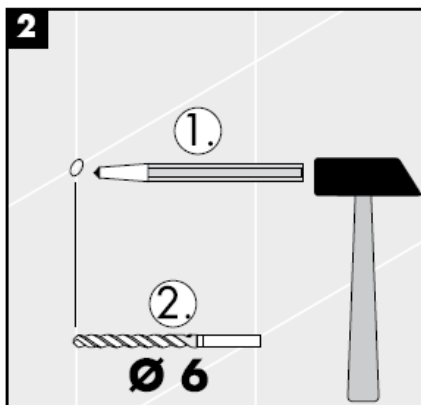
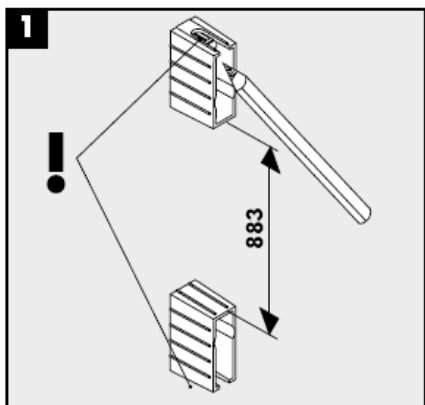

Koristerengas vain mallissa kromi/kulta!

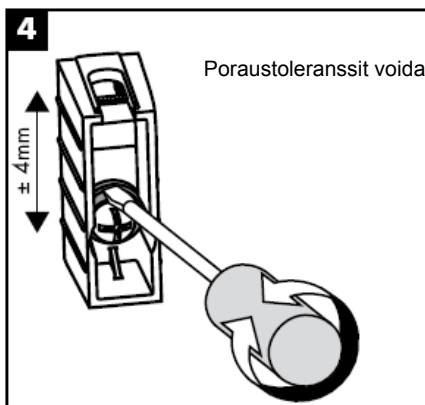

Poraustoleranssit voidaan tasata epäkeskokohteilla.

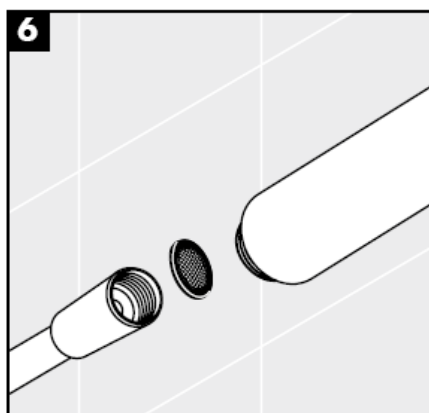
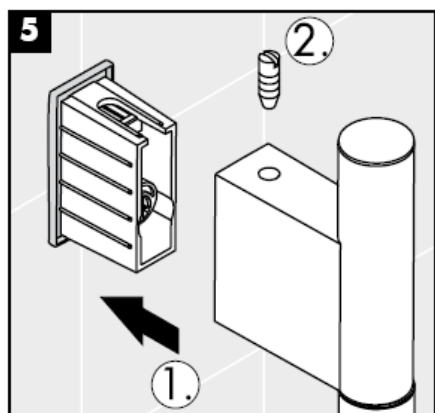

Käsिसuihkun mukana toimitettu sihtitiiviste on asennettava paikalleen, jotta lian huuhtoutuminen vesijohtoverkostosta käsisisuihkuun estyy. Huuhtoutuvat likahiukkaset voivat häiritä suihkun toimintaa tai vahingoittaa toimintaosia, Hansgrohe ei vastaa tästä aiheutuneista vahingoista.

Käsisisuihkun mukana toimitettu suodatinpatruuna (A) on asennettava paikalleen, jotta käsisisuihkun normaalivirtaus olisi taattuna ja, jotta lian huuhtoutuminen vesijohtoverkostosta käsisisuihkuun estyy. Jos halutaan suurempaa vesimäärää, suodatinpatruunan (A) tilalle voidaan asentaa sihtitiiviste (B). Huuhtoutuvat likahiukkaset voivat häiritä suihkun toimintaa tai vahingoittaa toimintaosia, Hansgrohe ei vastaa tästä aiheutuneista vahingoista.

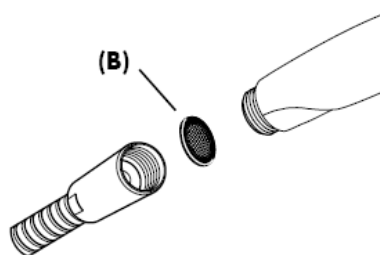
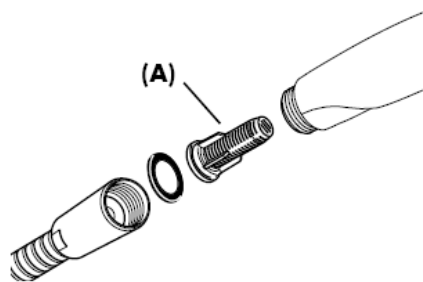

Säätö

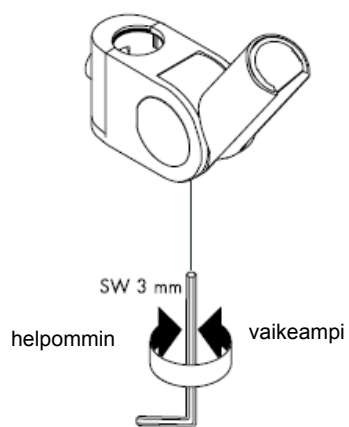
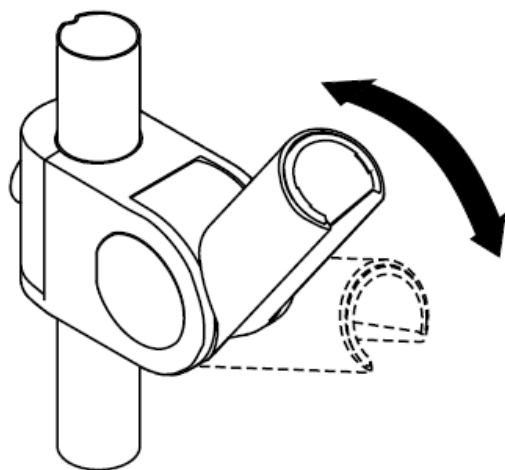
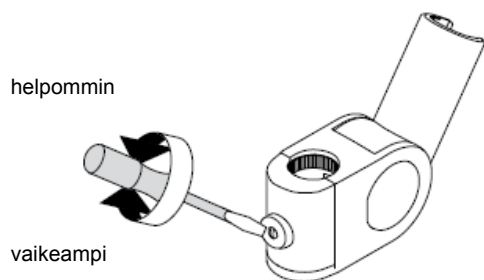
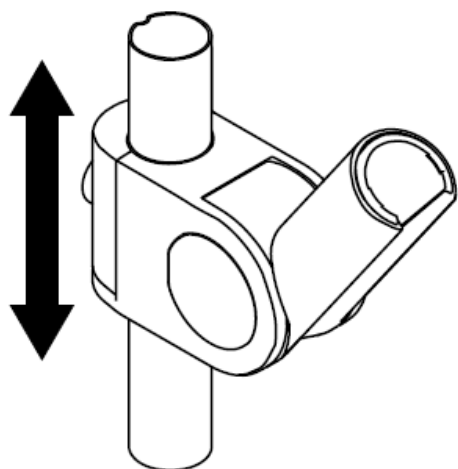

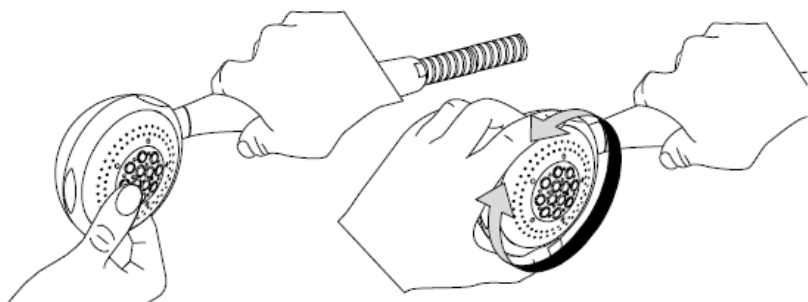

Rubit® –käsitoiminen kalkinpoistojärjestelmä on helppo käyttää: hiero sormella ja vedentulo on taas esteetön.



Hoito-ohje

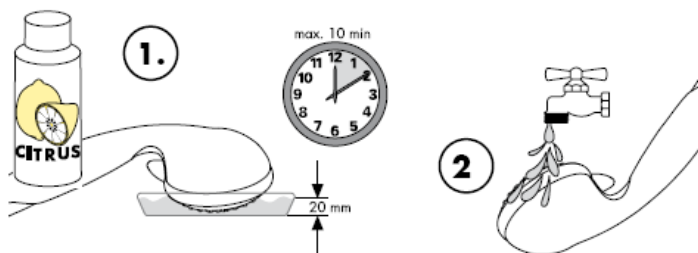

Puhdistus

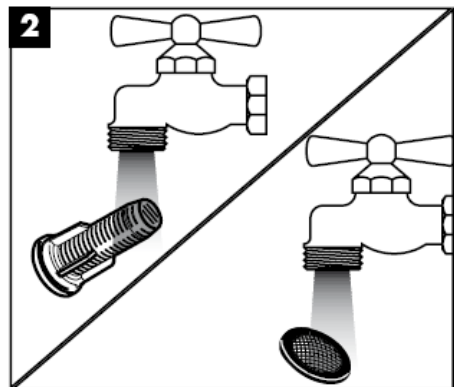
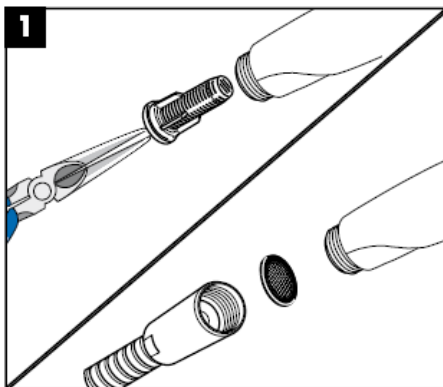
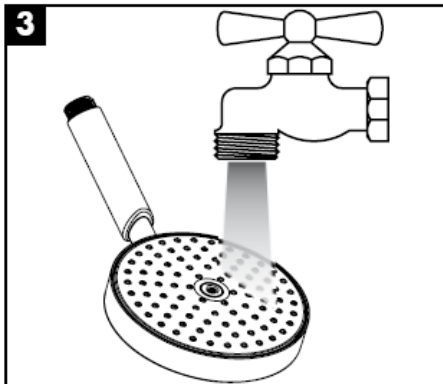
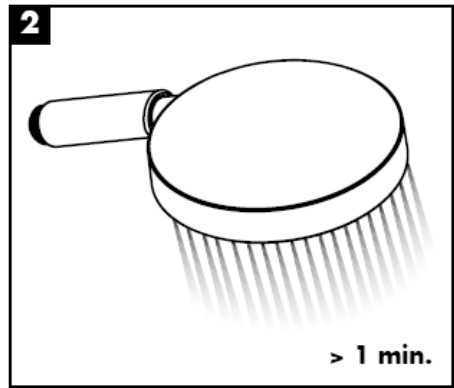
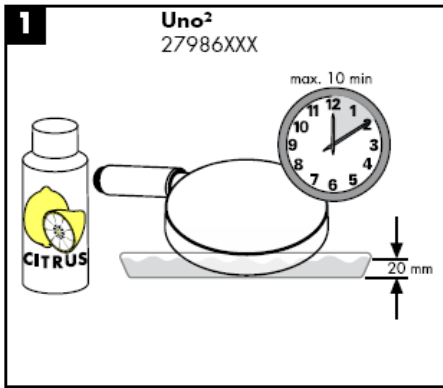

hansgrohe

Monteringsanvisning

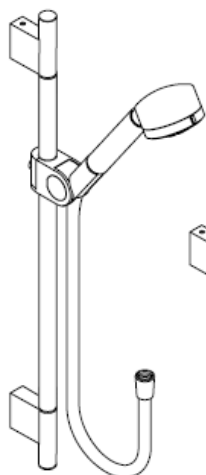

Uno/Arco
27985XXX

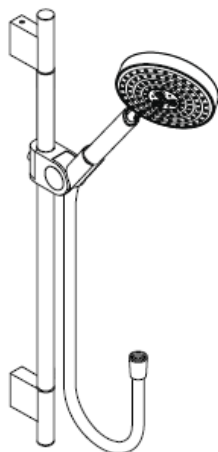

Uno²
27986XXX

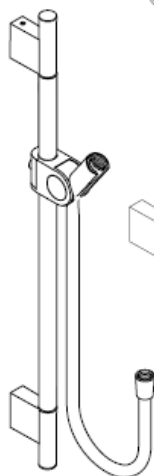

Uno
27989XXX

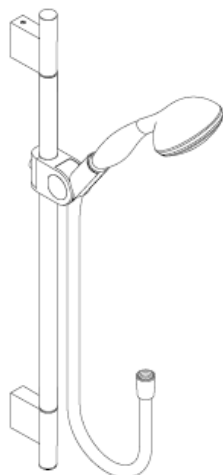

Allegroh
27956000

AXOR[®]

hansgrohe

Uno/Arco 27985XXX

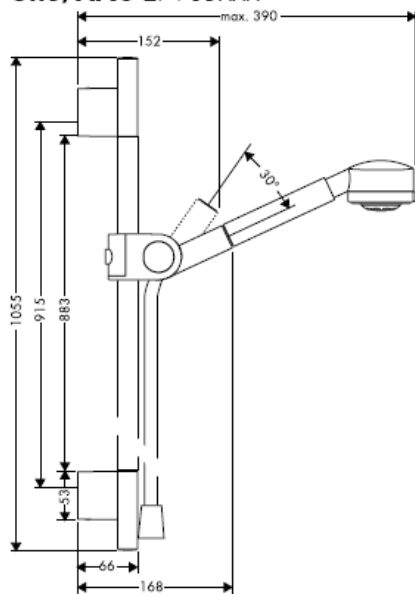

Uno² 27986XXX

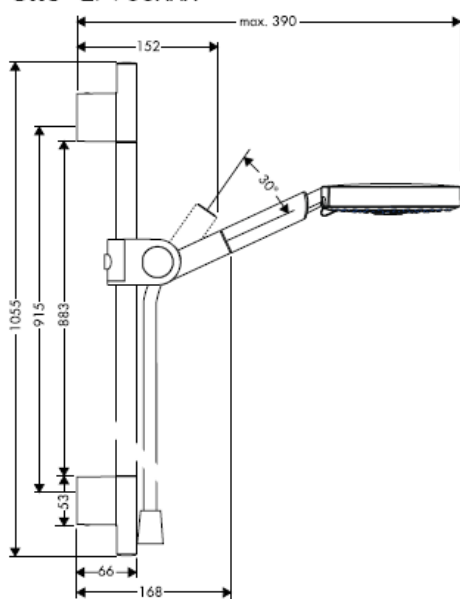

Uno 27989XXX

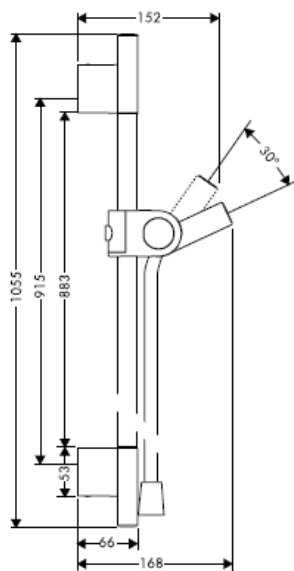

Allegroh 27956000

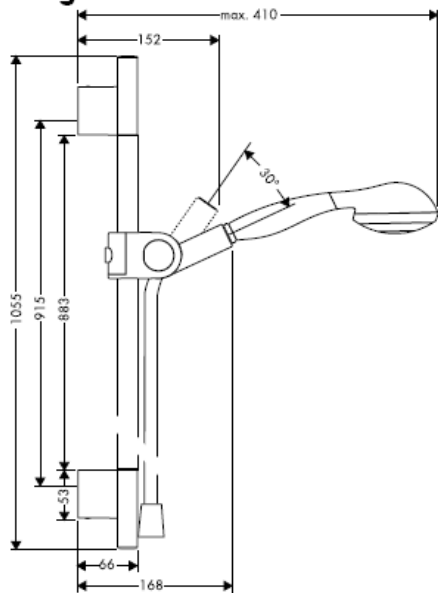



Optimal funktion garanteras bar tillsammans med Hansgrohe handduschar och Hansgrohe duschslangar. Duschslangar är endast avsedda till att ansluta duschar på blandare. Det är inte tillåtet att lägga in en spärr efter slangen och i flödesriktningen!

Tekniska data

Driftstryck:	max. 0,6 MPa
Rek. driftstryck: (1 MPa = 10 bar = 147 PSI)	0,1 – 0,4 MPa
Varmvattentemperatur:	max. 60° C

Handduschen är avsedd för användning med vattenberedare som har en effekt från 21 kW och ett minsta genomflöde på 7 l/min.

Uno/Arco 27985XXX

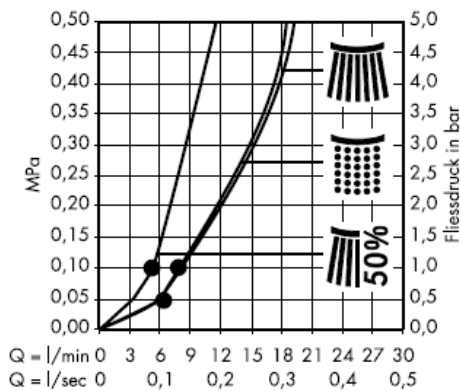
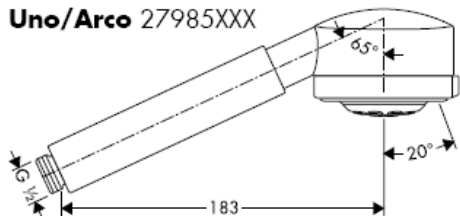

Normalstråle



Softstråle



Ecostråle

Allegroh 27956000

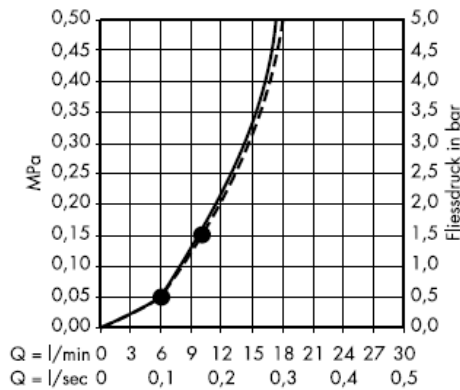
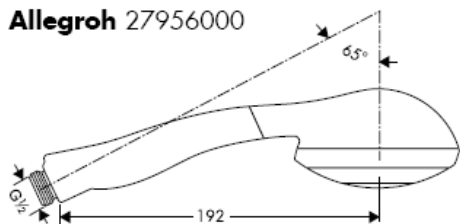

Normalstråle



Softstråle

Uno² 27986XXX

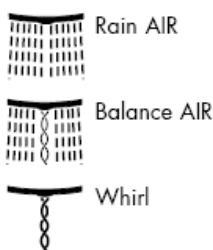
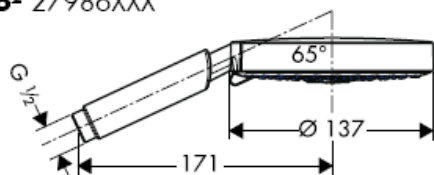

Med filterinsats (A)

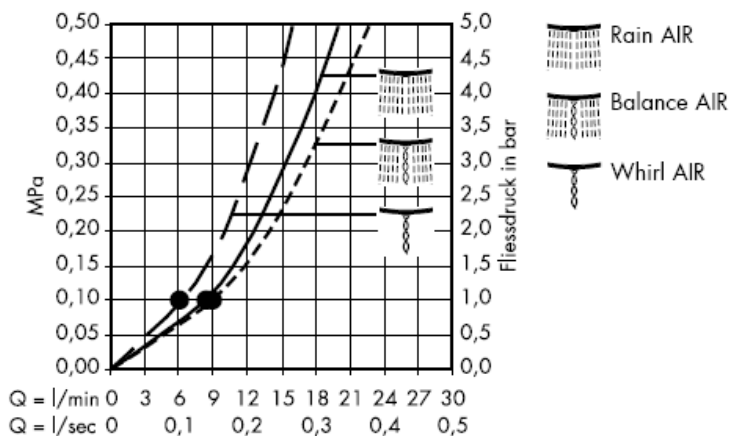

Med silpackning (B)

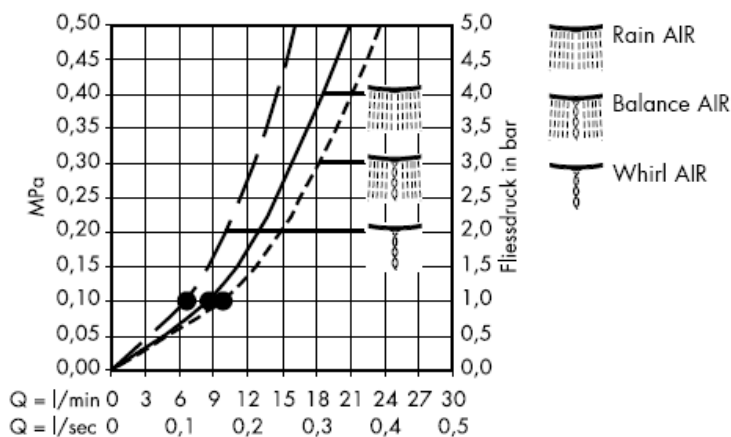

Från • garanteras funktionen.

Anpassa måtten till kakelmönstret så långt detta är möjligt.

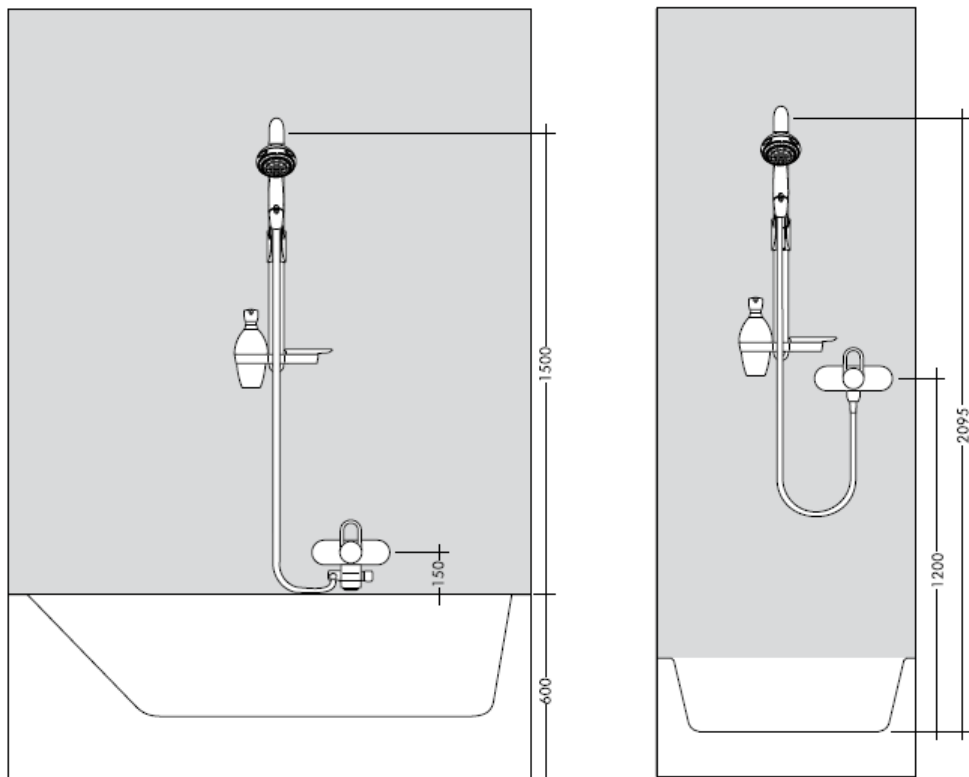

När kvalificerad fackpersonal monterar produkten är det viktigt att tänka på att monteringsytan är plan i alla delar av arbetsytan (inga fogar som sticker ut eller klinkerförskjutningar), att väggkonstruktionen passar till montering av produkten samt att den inte har svaga punkter. Medföljande skruvar och plugg är endast avsedda för betong. Vid andra väggkonstruktioner skall anvisningarna från pluggtillverkaren beaktas.

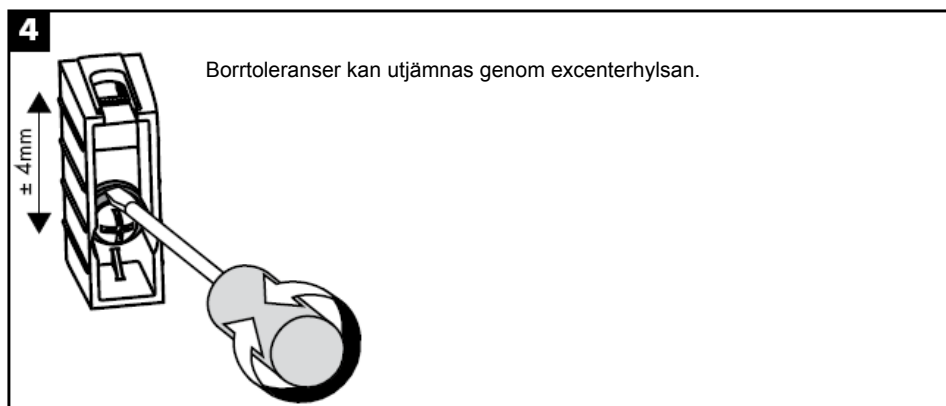
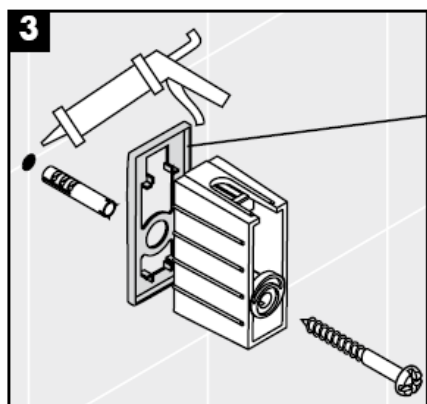
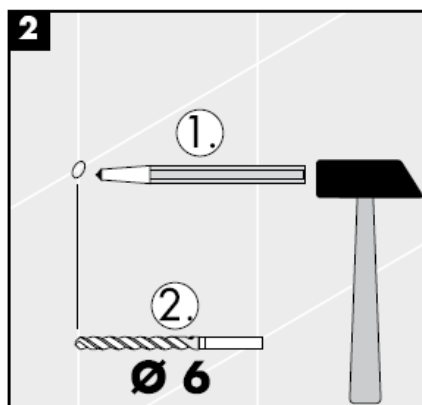
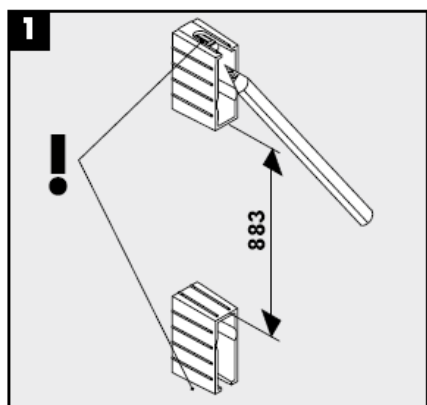

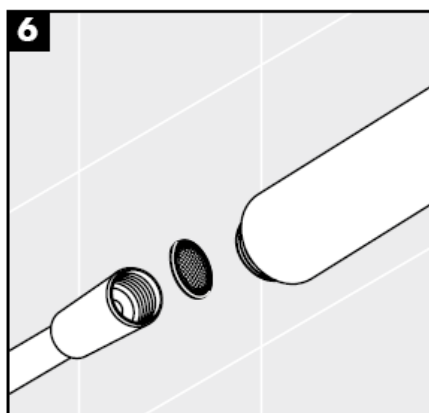
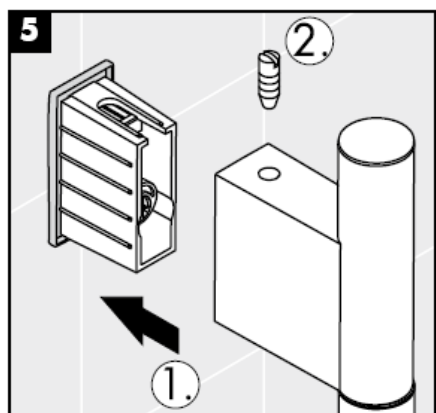

Silpackningen som följer med duschen måste monteras för att undvika att smuts från ledningsnätet tränger in. Smuts som spolats in kan påverka funktionerna och/eller leda till skador på funktionsdelar i duschen. Hansgrohe fransäger sig allt ansvar för skador som kan härledas till detta.

Filterinsatsen (A) som följer med måste monteras om normalflödet hos handduschen ska vara garanterat och för att undvika att smuts spolats in från ledningsnätet. Önskas kraftigare vattenflöde måste silpackningen (B) användas istället för filterinsatsen (A). Smuts som spolats in kan påverka funktionerna och/eller leda till skador på funktionsdelar i handduschen. Hansgrohe fransäger sig allt ansvar för skador som kan härledas till detta.

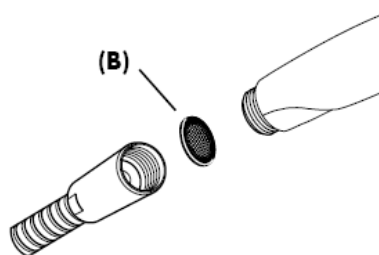
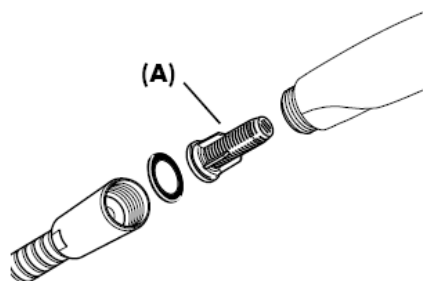

Inställning av maxtemperatur

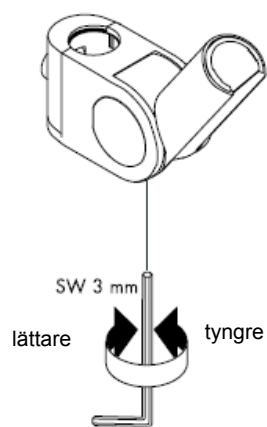
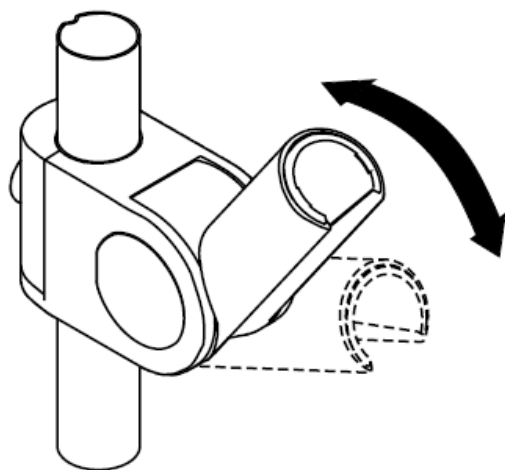
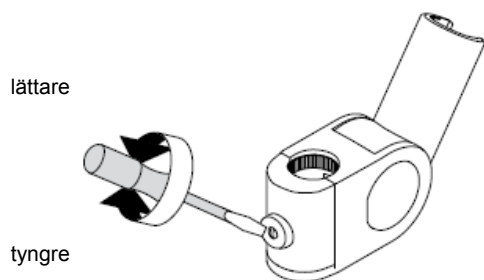
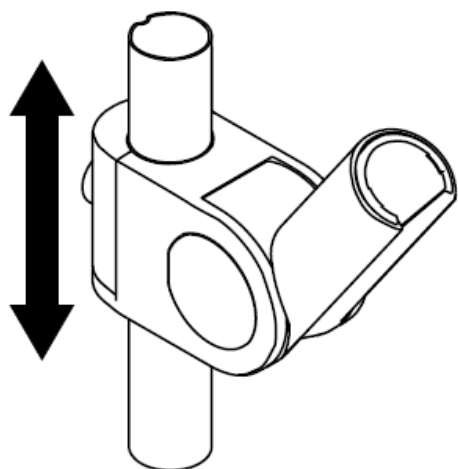

Rengöring

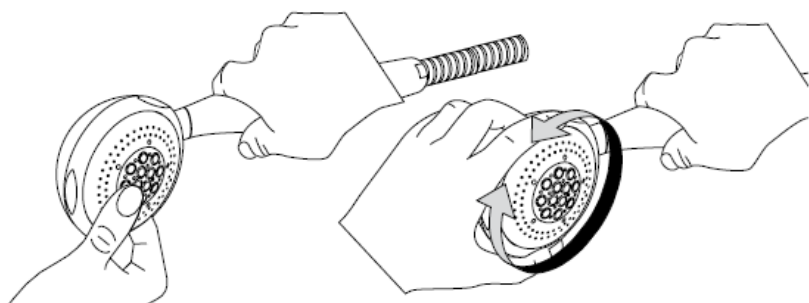

Med Rubit®, den manuella rengöringsfunktionen, är det lätt att befria strålkanelerna från kalk - de ska bar gnuggas.



Skötselanvisningar

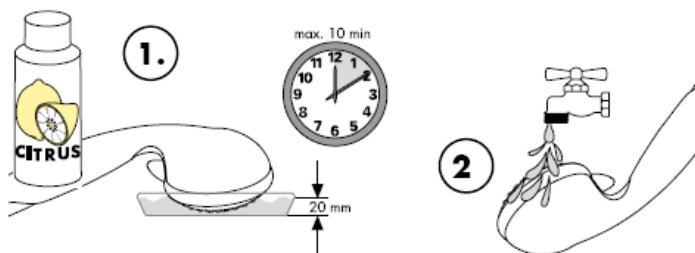

Rengöring

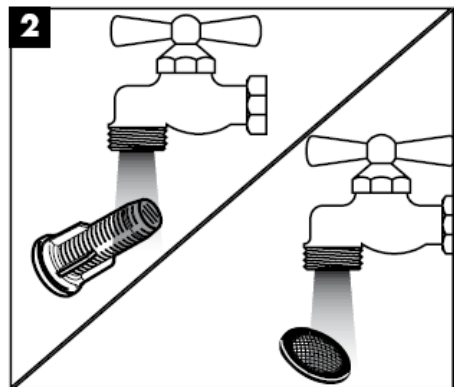
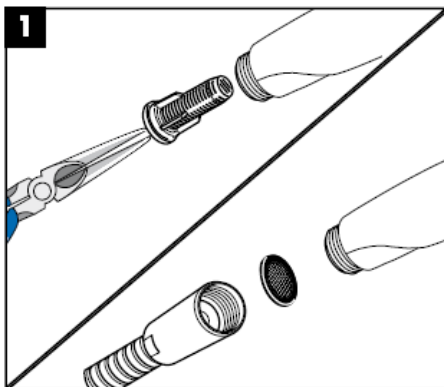
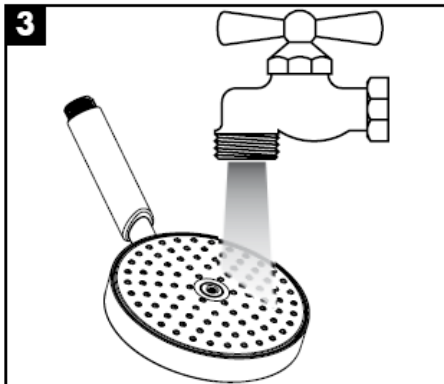
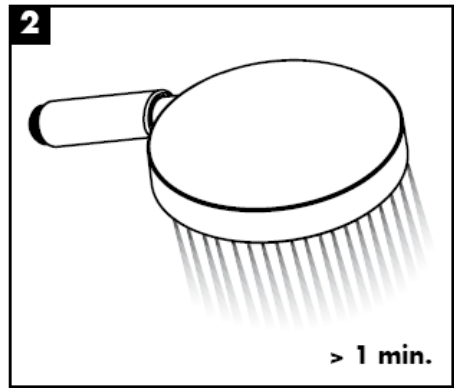
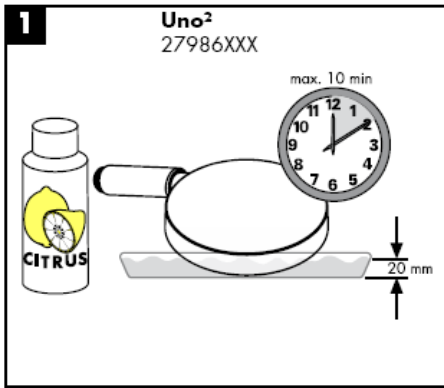

hansgrohe

Montavimo instrukcijos

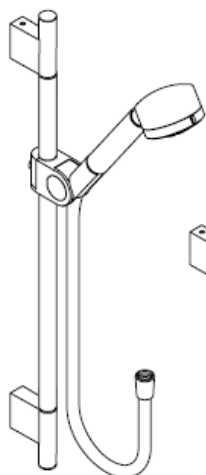

Uno/Arco
27985XXX

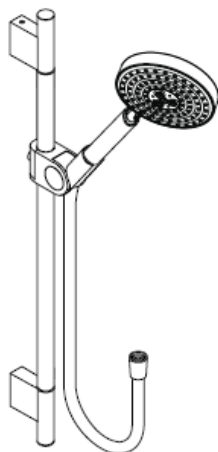

Uno²
27986XXX

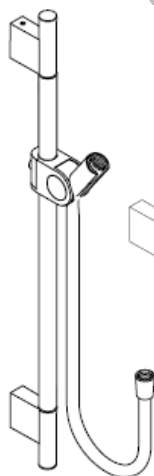

Uno
27989XXX

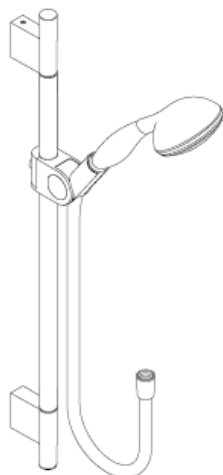

Allegroh
27956000

AXOR®

hansgrohe

Uno/Arco 27985XXX

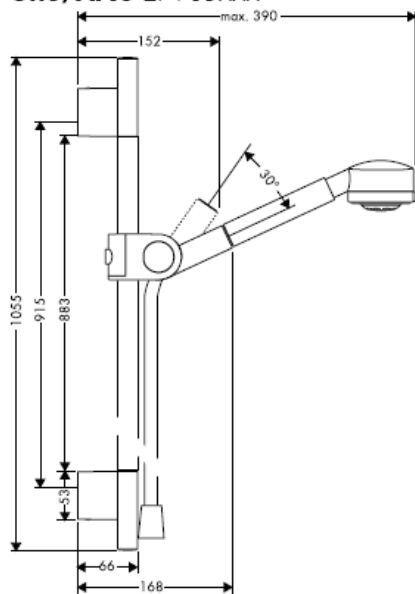

Uno² 27986XXX

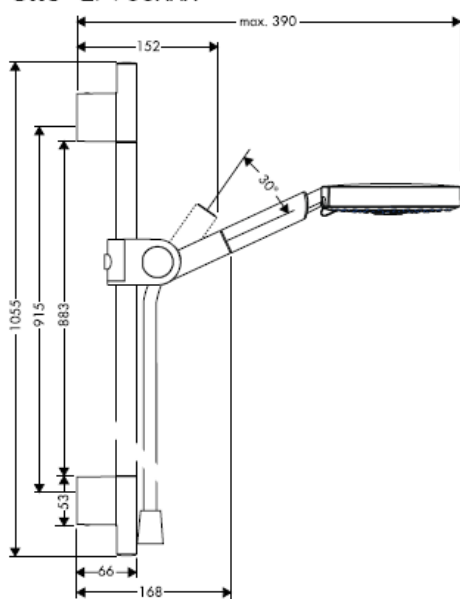

Uno 27989XXX

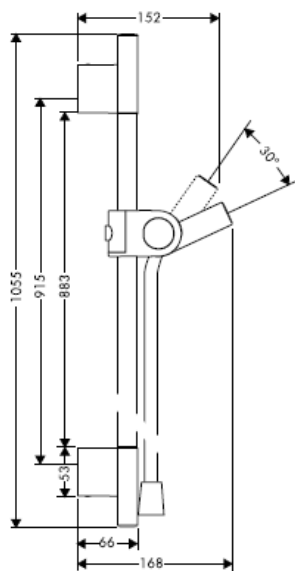

Allegroh 27956000

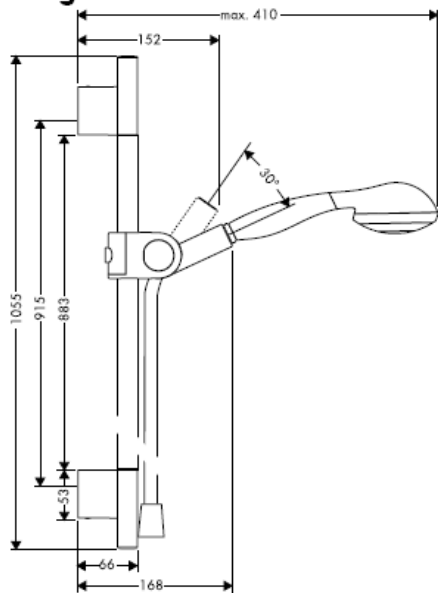



Optimalus funkcionavimas yra garantuojamas tik naudojant "Hansgrohe" rankų dušus su "Hansgrohe" dušo žarnos. Dušo žarnos yra pritaikytos tik prijungti dušo galvutę prie vandens maišytuvo. Negalima montuoti vandens uždarymo mechanizmo tarp maišytuvo ir žarnos.

Techniniai duomenys

Darbinis slėgis:	max. 0,6 MPa
Rekomenduojamas slėgis: (1 MPa = 10 barų = 147 PSI)	0,1 – 0,4 MPa
Karšto vandens temperatūra:	max. 60° C

Dušo galvutė pritaikyta momentiniam vandens šildikliui nuo 21 kW su ne mažesniu kaip 7 l/min vandens pralaidumu.

Uno/Arco 27985XXX

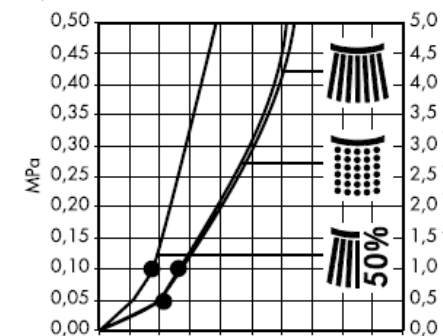
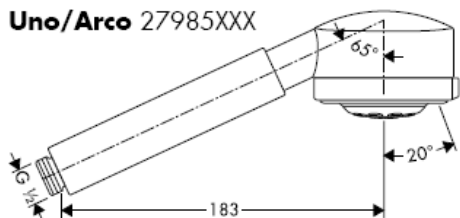

Normali srové



Minkšta srové



Ekonominis režimas

Allegroh 27956000

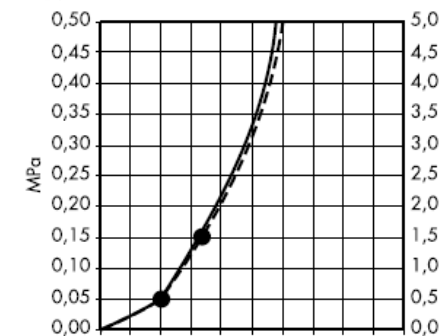
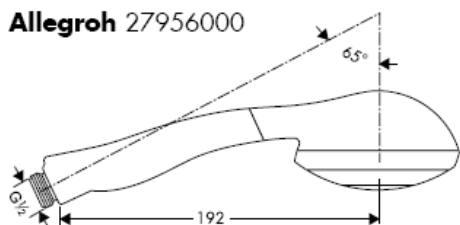

Normali srové



Minkšta srové

Uno² 27986XXX

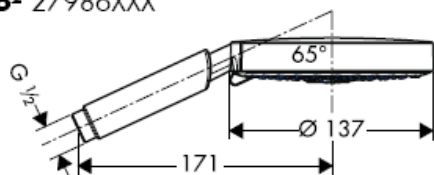

Rain AIR



Balance AIR



Whirl



Su filtru (A)

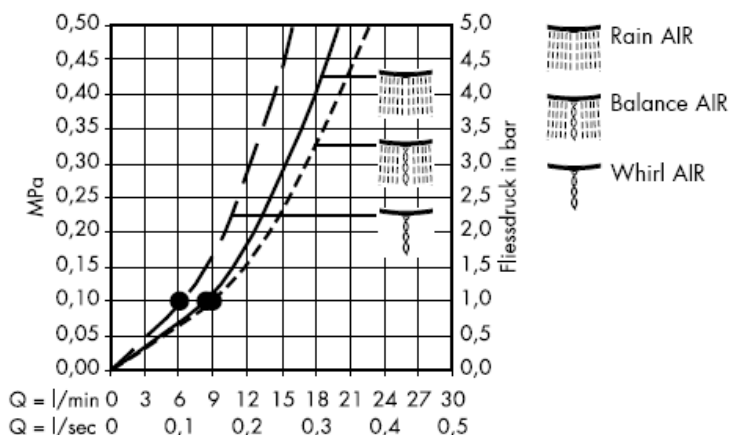

Su sieteliu (B)

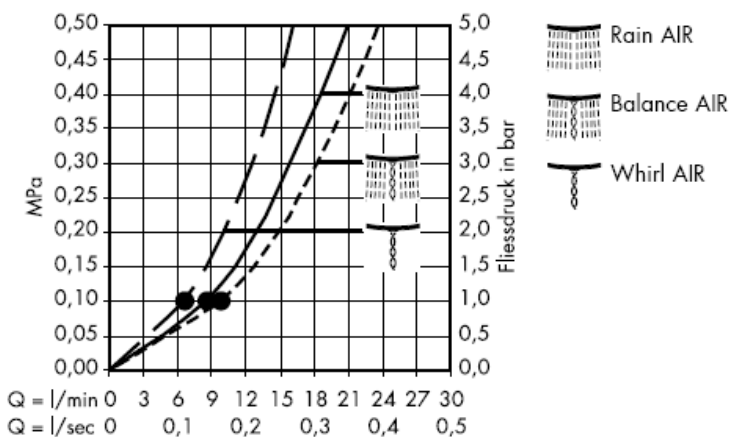

Nuo • funkcionavimas garantuotas

Jei įmanoma, kabindami stovą derinkite prie plytelių.

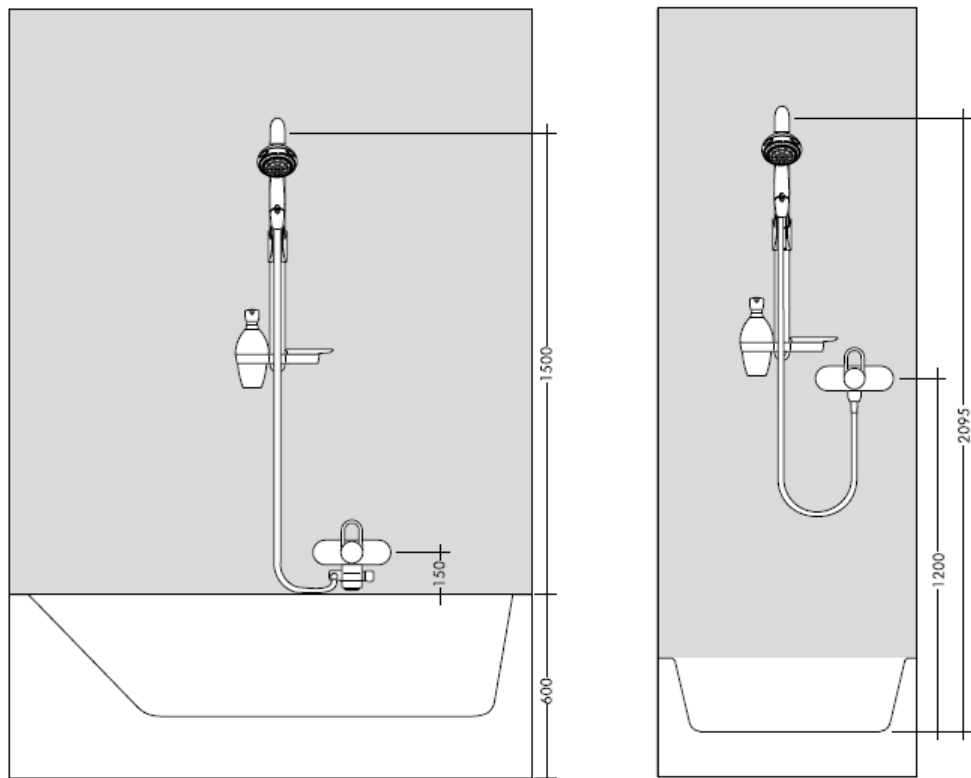

Montuojant produktą, specialistas privalo įsitikinti, kad sienos plotas, prie kurio dedama montavimo plokštė, yra lygus (jokių plytelių ar kitų nelygumų), kad sienos struktūra yra pritaikyta produkto montavimui ir neturi jokių silpnų vietų.

Pakuotėje esantys varžtai ir kaiščiai yra skirti tik betonui. Esant kitokiai sienai, varžtus ir kaiščius reikia rinktis pagal paskirtį.

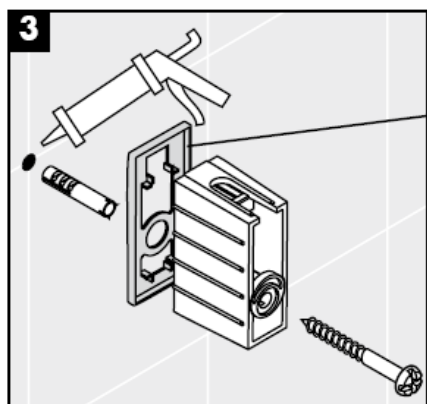
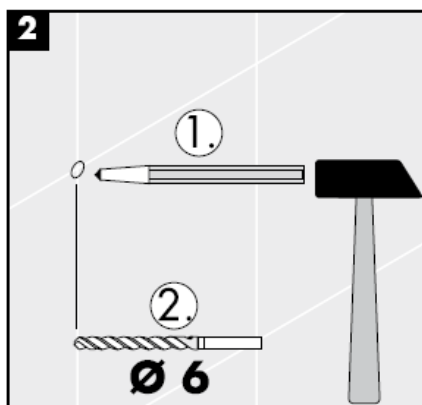
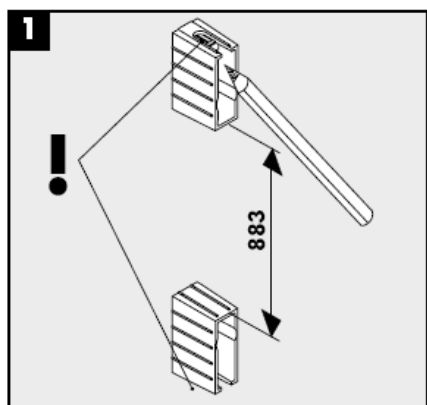

Dekoratyviniis žiedas tik chrominiam (aukso) variantui!

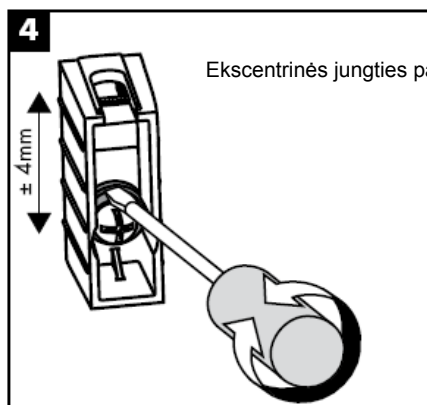

Ekscentrinės jungties pagalba galima išlyginti išgręžtų angų nuokrypį.

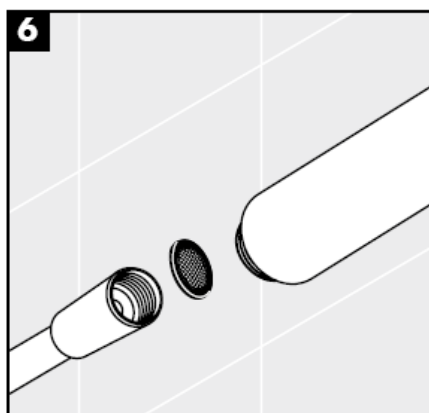
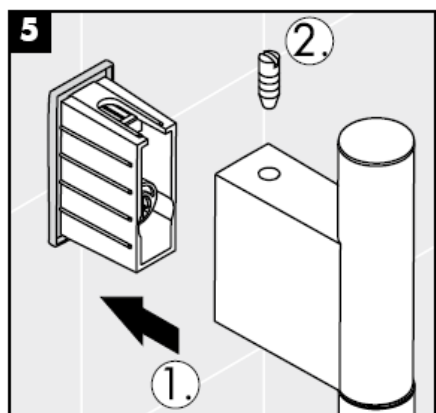

Tinklelis, kuris yra rankų dušas pakuotėje, privalo būti įstatytas, kad būtų apsaugota nuo išorės nešvarumų. Nešvarumai gali pakenkti rankų dušas funkcionalumui ir (arba) sugadinti rankų dušas funkcines dalis. Tokiu atveju "Hansgrohe" atsakomybės nepriima.

Filtrą (A), kuris yra rankų dušas pakuotėje, privalo būti įstatytas, kad būtų garantuota vandens pralaidumo norma ir apsauga nuo nešvarumų. Jei reikia didesnio vandens pralaidumo, vietoje filtro (A) įstatykite sietelį (B). Nešvarumai gali pakenkti rankų dušas funkcionalumui ir (arba) sugadinti rankų dušas funkcines dalis. Tokiu atveju "Hansgrohe" atsakomybės nepriima.

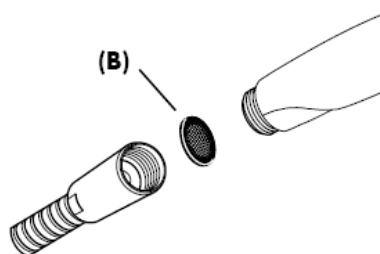
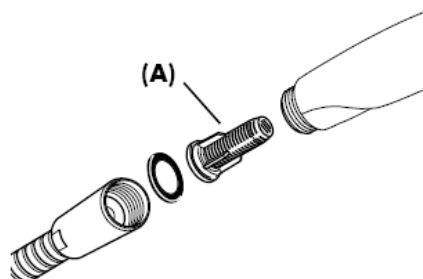

Nustatymas

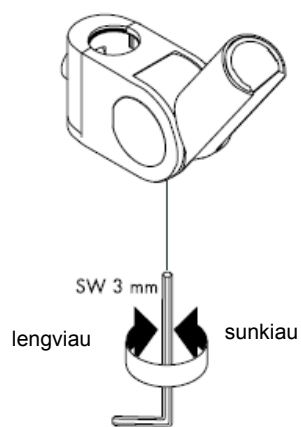
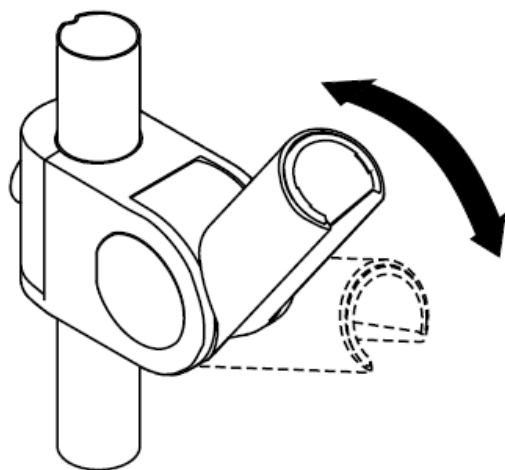
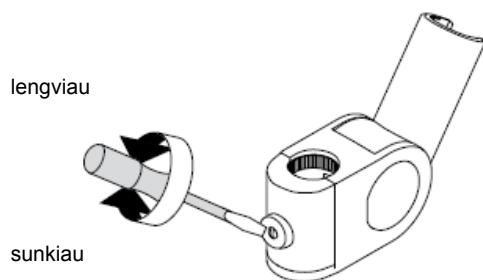
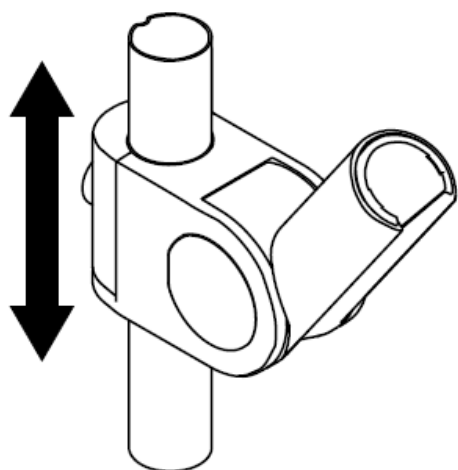

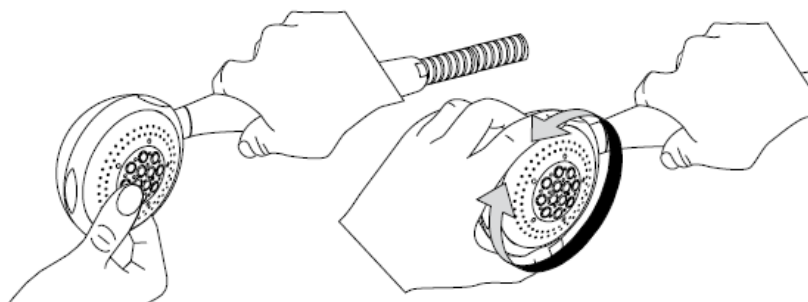

"Rubit®" valymo funkcija apsaugo nuo apkalkėjimo. Užtenka pirštu nubraukti atsiradusius nešvarumus nuo srovės angų.



Valymo instrukcijos

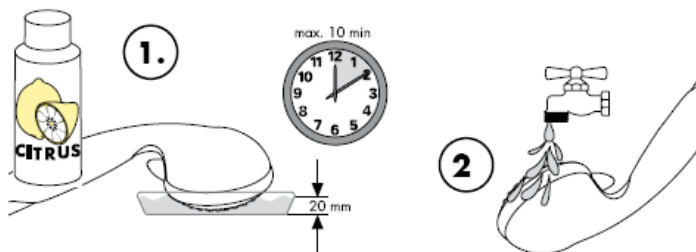

Valymas

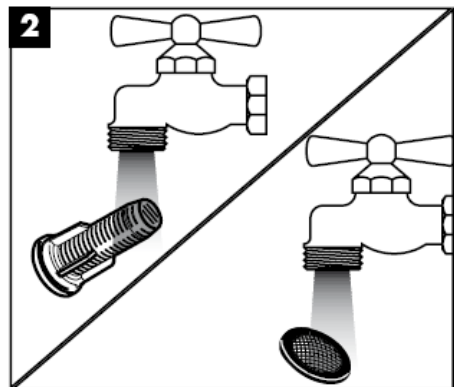
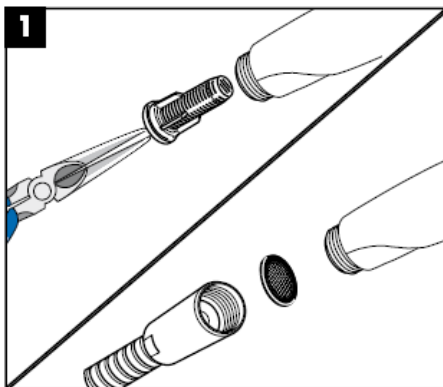
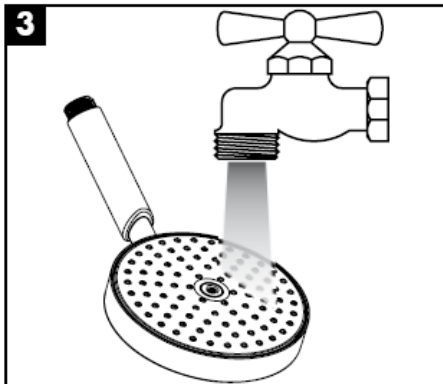
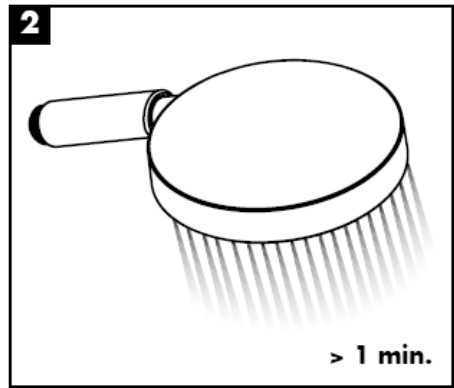
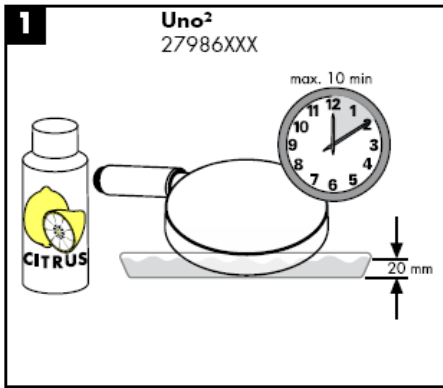

hansgrohe

Uputstva za instalaciju

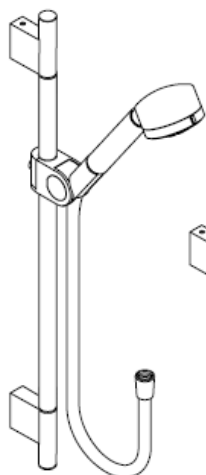

Uno/Arco
27985XXX

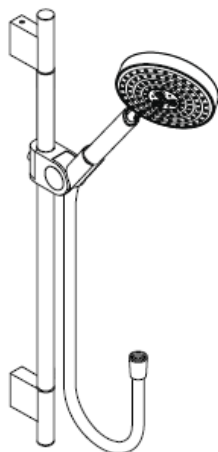

Uno²
27986XXX

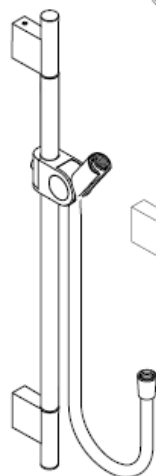

Uno
27989XXX

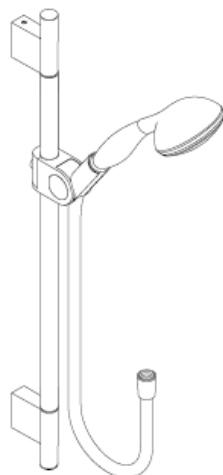

Allegroh
27956000

AXOR®

hansgrohe

Uno/Arco 27985XXX

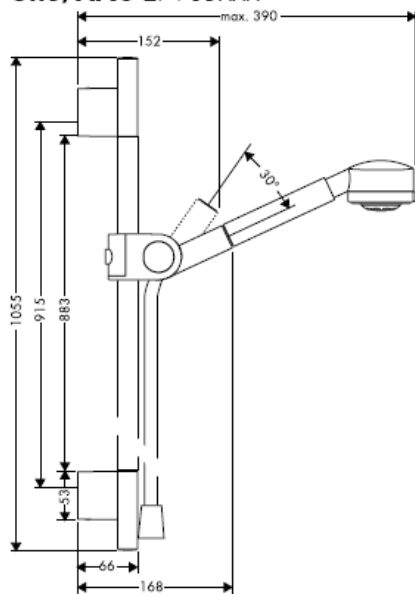

Uno² 27986XXX

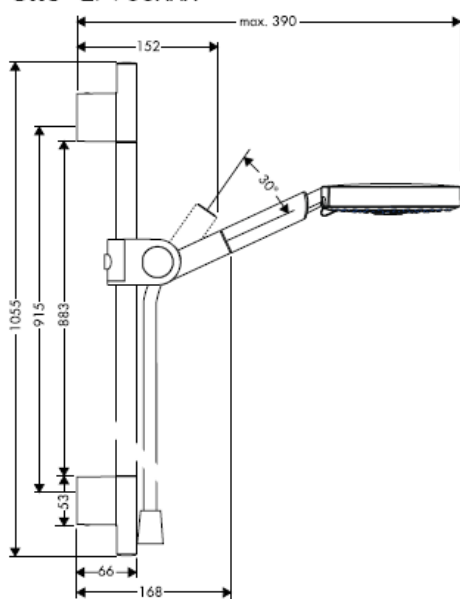

Uno 27989XXX

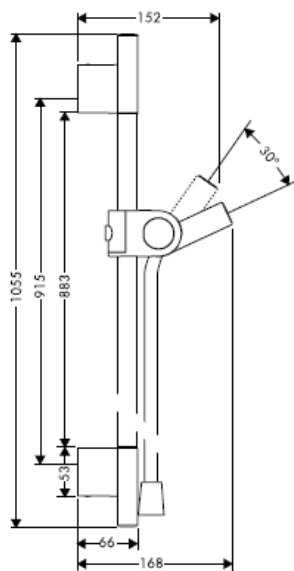

Allegroh 27956000

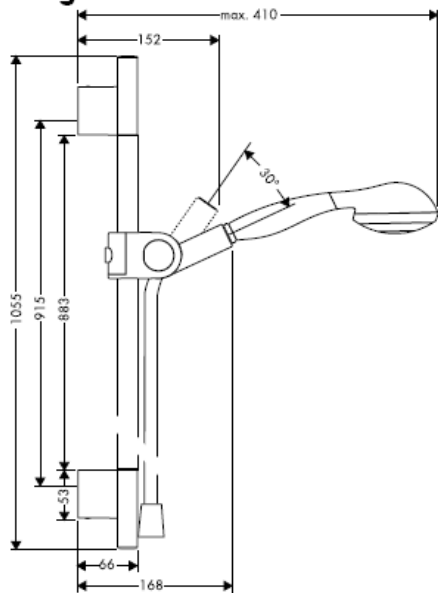



Optimalno funkcioniranje zajamčeno je jedino u kombinaciji sa Hansgrohe ručnim tuševima i Hansgrohe crijevom za tuš. Crijeva tuša prikladna su jedino za spajanje tuševa na armature. Nije dopušteno zatvaranje crijeva u smjeru protoka vode!

Tehnički podatci

Najveći dopušteni tlak:	max. 0,6 MPa
Preporučeni tlak: (1 MPa = 10 bar = 147 PSI)	0,1 – 0,4 MPa
Temperatura vruće vode:	max. 60° C

Ručni tuš možete koristiti uz protočni bojler od 21 kW te uz minimalni protok od 7 litara u minuti

Uno/Arco 27985XXX

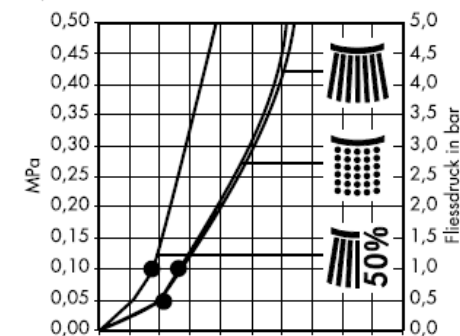
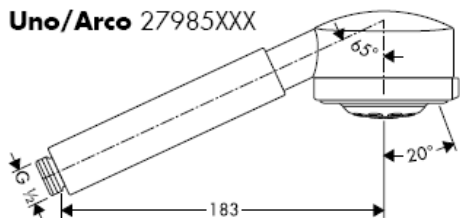

Normalni mlaz



Nježni mlaz



Eko mlaz

Allegroh 27956000

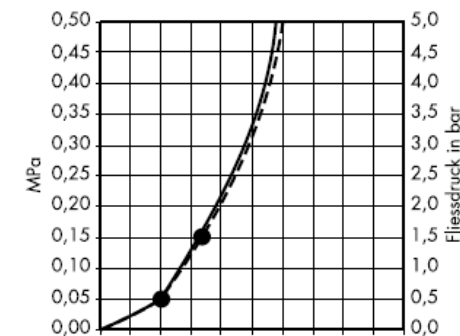
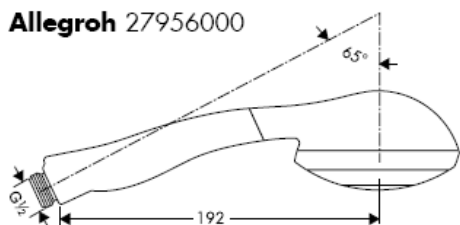

Normalni mlaz



Nježni mlaz

Uno² 27986XXX

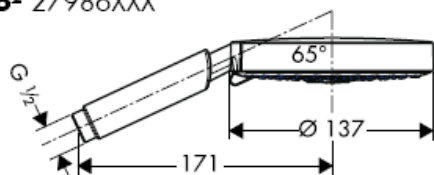

Rain AIR



Balance AIR



Whirl



Sa filterom (A)

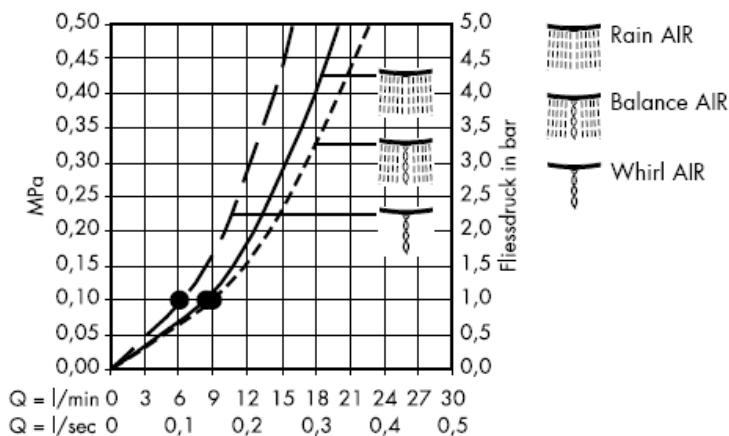

Sa rešetkastim filterom (B)

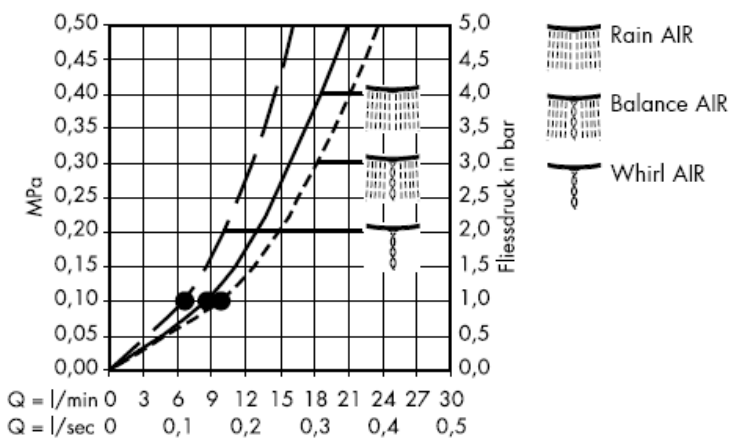

Zajamčena funkcija od • navíše

Prilagodite mjeru što je više moguće rasteru pločica

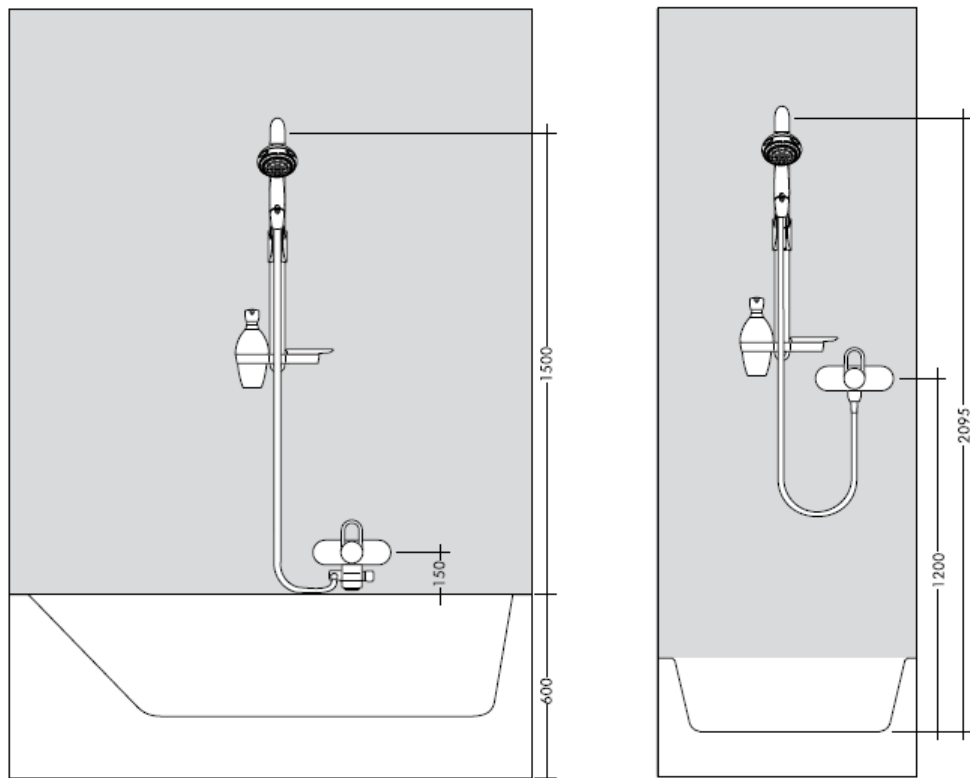

Kada proizvod montira kvalificirano stručno osoblje treba paziti da čitava površina na koju se učvršćuje bude ravna (bez istaknutih fuga ili krivljenja pločica), da je zidna konstrukcija primjerena montaži proizvoda te osobito da nema slabih mjesta.

Priloženi vijci i moždanici prikladni su samo za beton. Kod drugih zidnih nadgradnji treba obratiti pažnju na navode proizvođača moždanika.

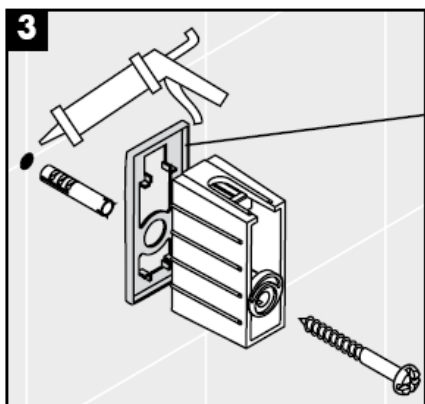
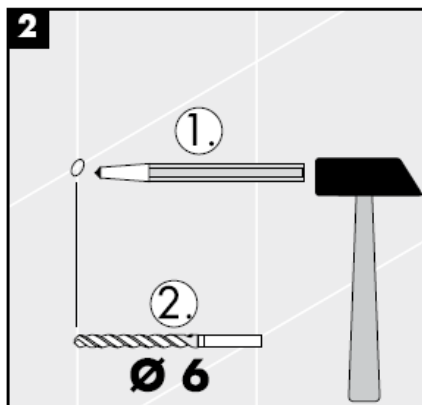
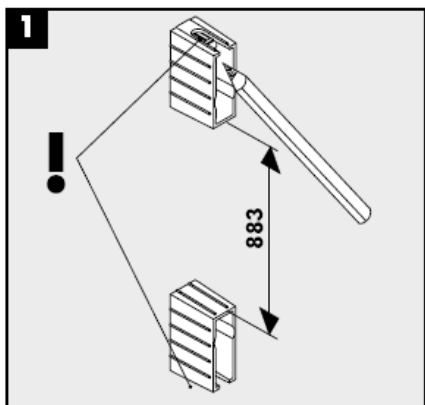

Ukrasni prsten samo kod varijante krom/zlato!

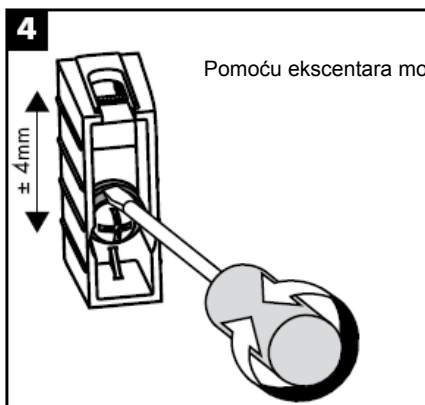

Pomoću ekscentara mogu se podesiti tolerancije provrta.

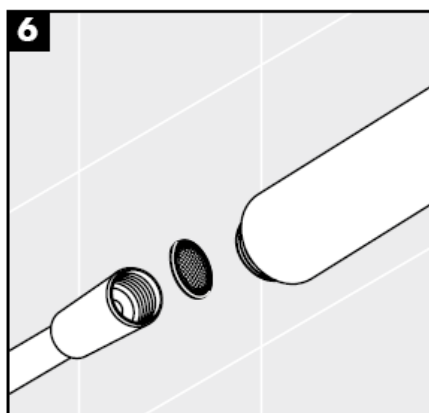
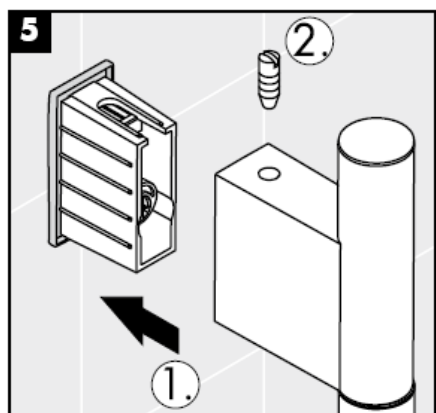

Filter (A) potrebno je ugraditi kako bi se regulirao protok vode i smanjio dotok prljavštine . Ako želite jači protok vode umjesto filtera ugradite rešetku (B) Za eventualna oštećenja uzrokovana prljavštinom proizvođač Hansgrohe nije odgovoran.

Filter (A) potrebno je ugraditi kako bi se regulirao protok vode i smanjio prolazak prljavštine. Ako želite jači protok vode umjesto filtera ugradite rešetku (B) Za eventualna oštećenja uzrokovana prljavštinom proizvođač Hansgrohe nije odgovoran.

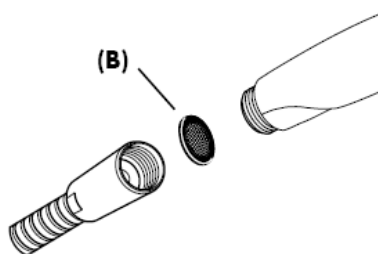
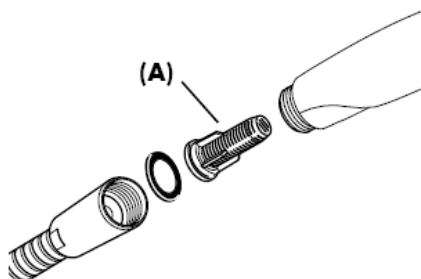

Regulacija

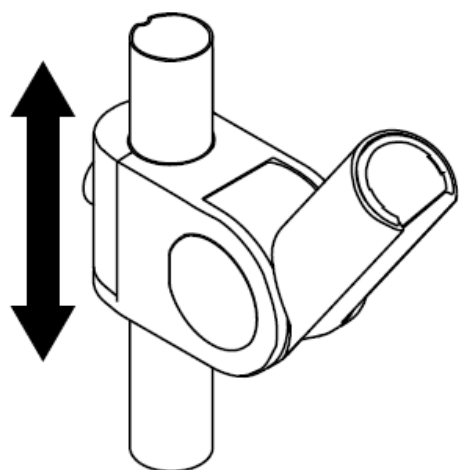

lakše

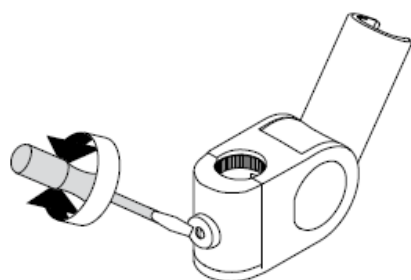

Teže

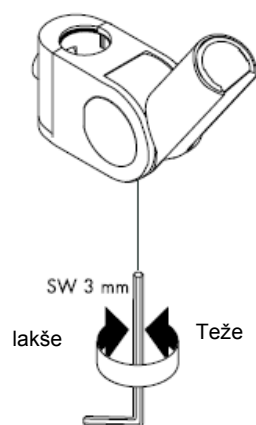
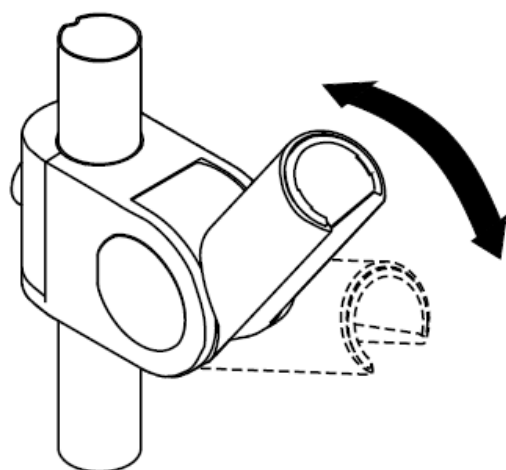

Čišćenje

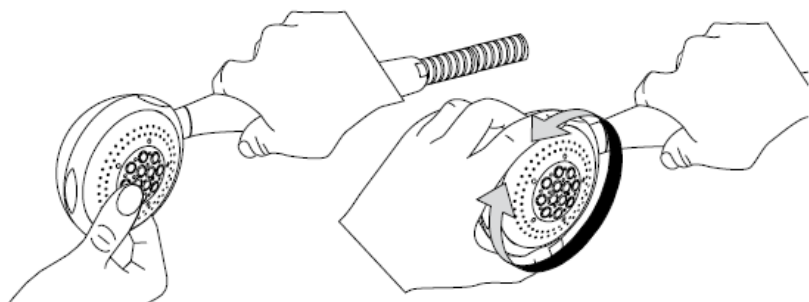

Rubit® - ručni sustav za čišćenje omogućuje jednostavnim trljanjem odstranjivanje kamenca sa rupica prskalice tuša.

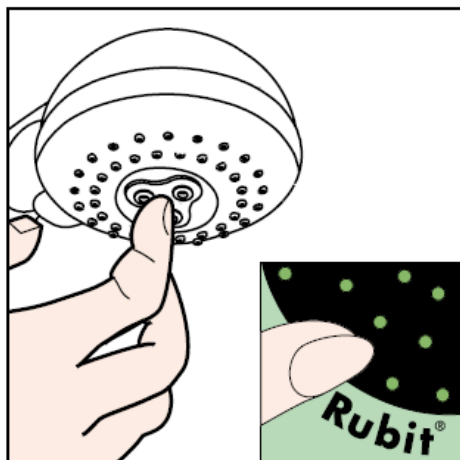

Uputstva za održavanje i čišćenje

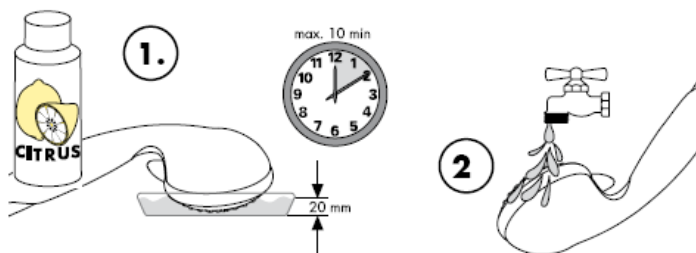

Čišćenje

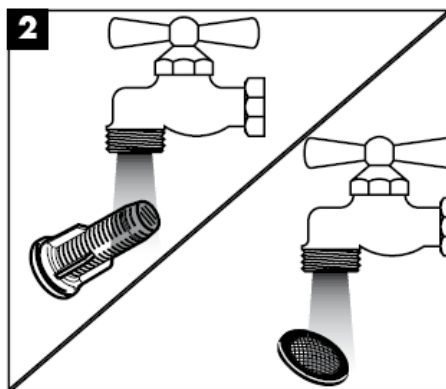
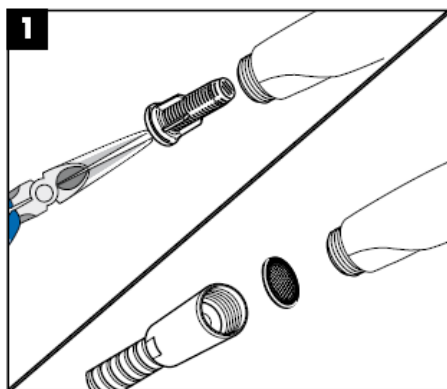
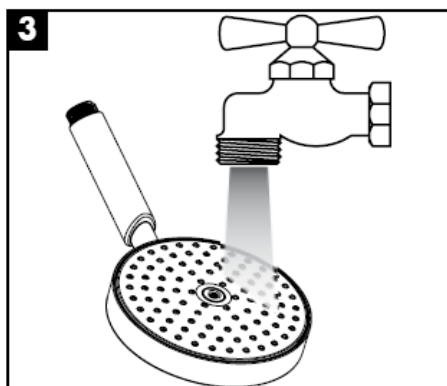
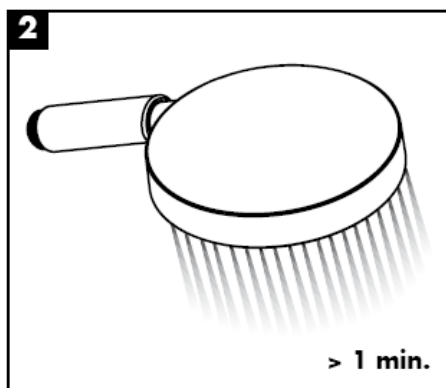
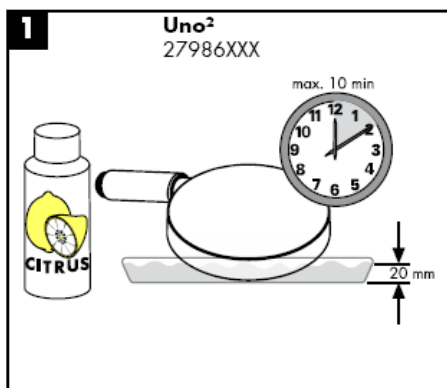

hansgrohe

Montaj kılavuzu

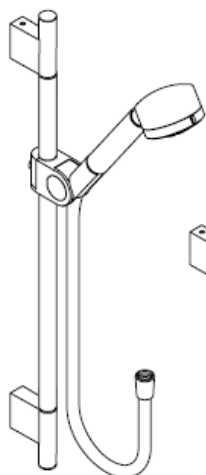

Uno/Arco
27985XXX

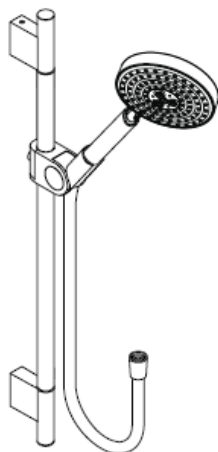

Uno²
27986XXX

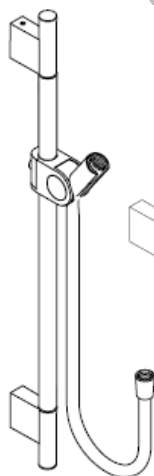

Uno
27989XXX

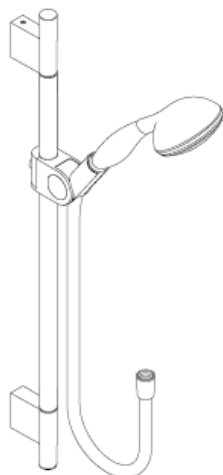

Allegroh
27956000

AXOR®

hansgrohe

Uno/Arco 27985XXX

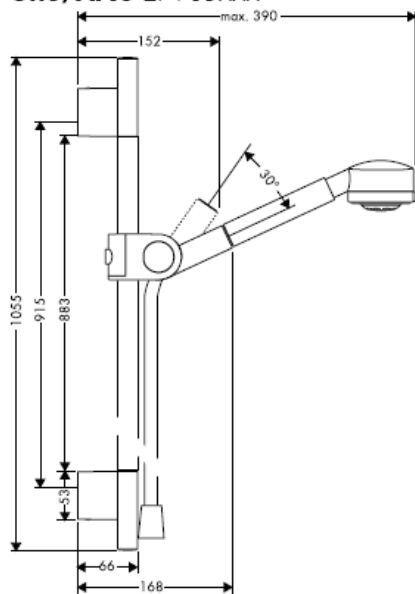

Uno² 27986XXX

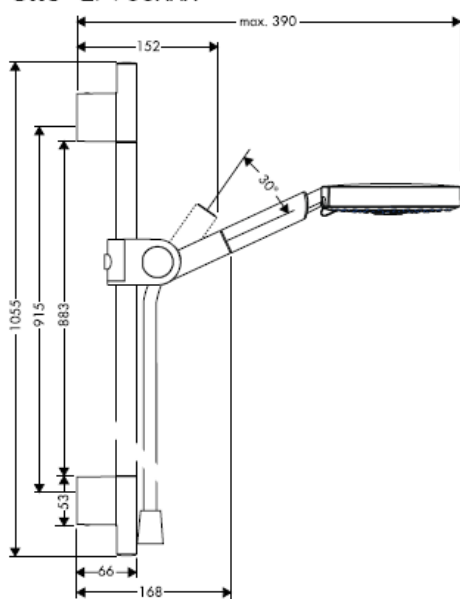

Uno 27989XXX

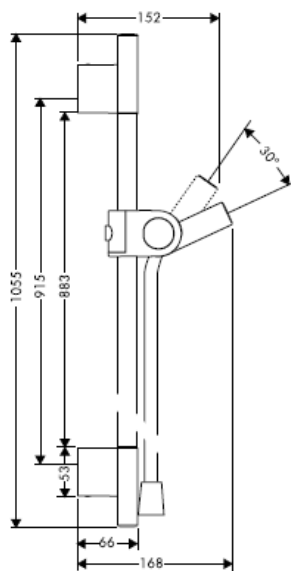

Allegroh 27956000

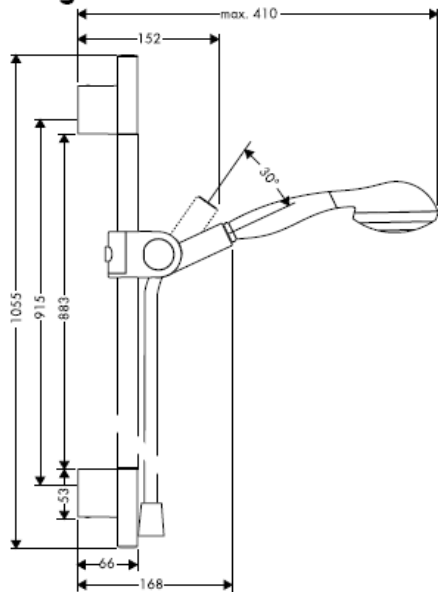



Mümkün olduğu kadar iyi işlev, yalnız Hansgrohe elle duş parçaları ve Hansgrohe duş boruları kullanılırsa, garanti edilir. Sözü geçen duş boruları, duş parçalarını yalnız donanım takımlarına bağlamaya yarar. Hortumun arkasından sonra akış yönünde kesmek yasaktır!

Teknik bilgiler

İşletme basıncı: max. 0,6 MPa
Tavsiye edilen işletme basıncı: 0,1 – 0,4 MPa
(1 MPa = 10 bar = 147 PSI)
Sıcak su sıcaklığı: max. 60° C

El duşu, 21 kW güçten ve 7 l/dk minimum debiden itibaren şofbenlerle kullanım için uygundur.

Uno/Arco 27985XXX

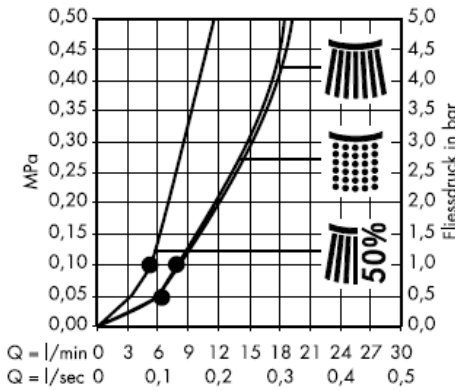
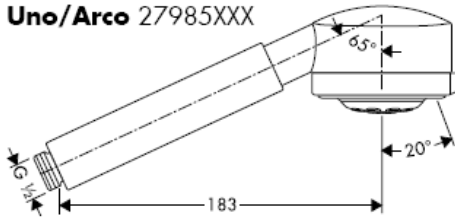

Normal duş



Yumuşak



Eco su akışı

Allegroh 27956000

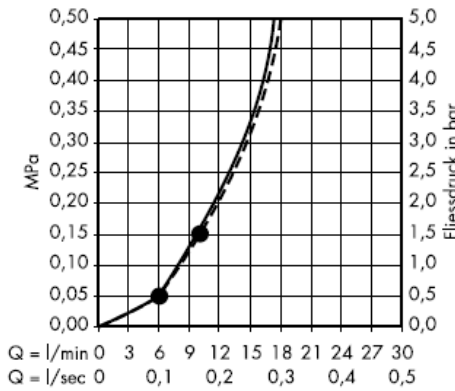
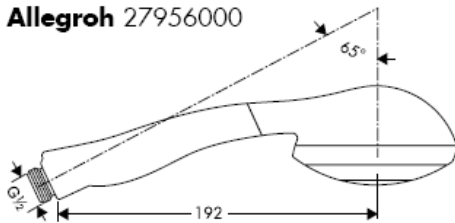

Normal duş



Yumuşak

Uno² 27986XXX

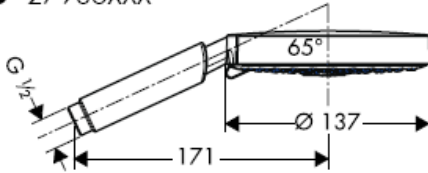

Rain AIR

Balance AIR

Whirl

Filtre adaptörlü (A)

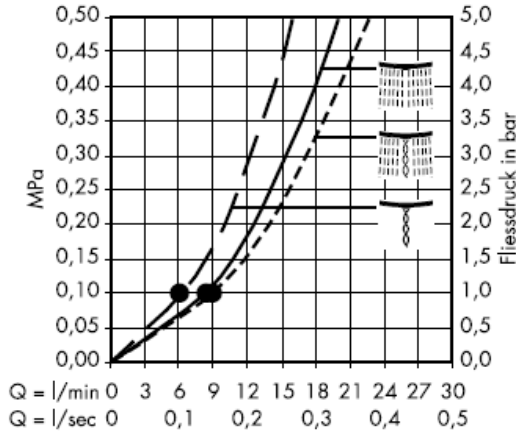

Süzgeç contalı (B)

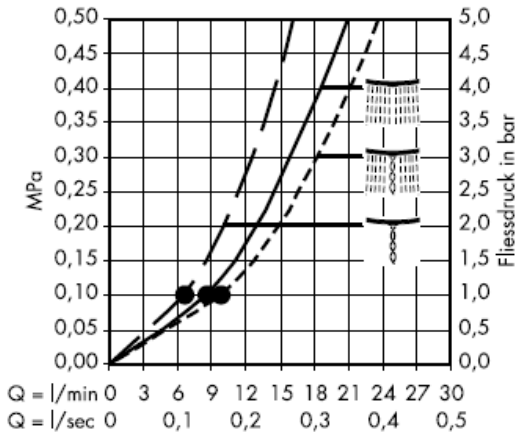

*den itibaren fonksiyon garanti edilmiştir.

Boyutları olabildiği kadar fayans tipine uyarlayın.

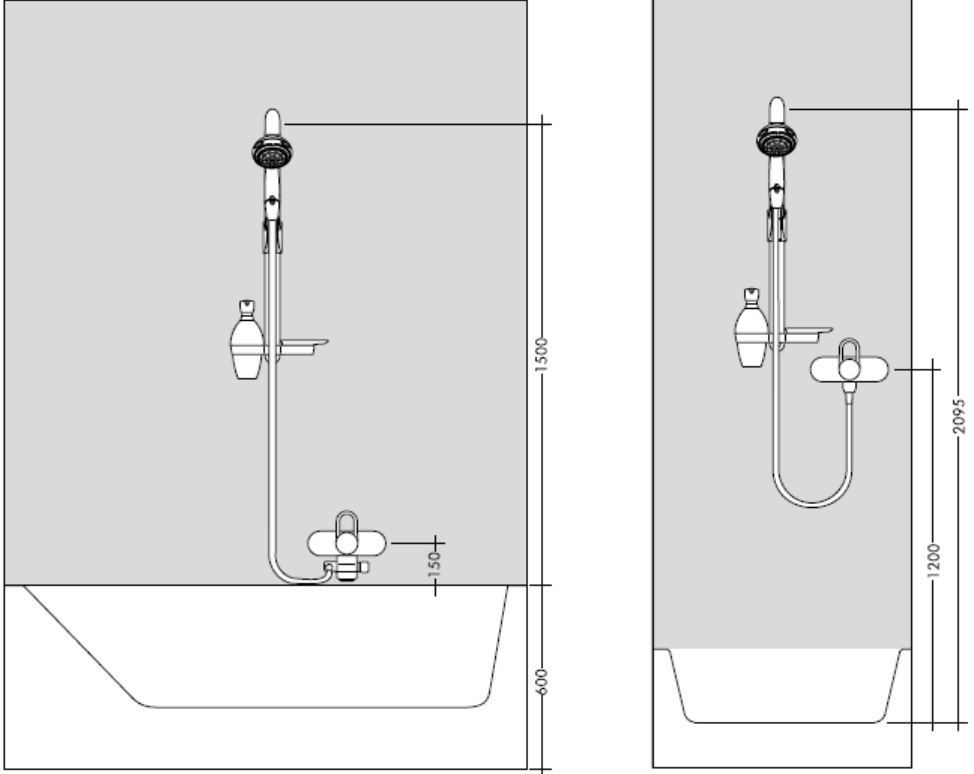

Müteahhit, ürünü monteleyeceği yer, yani montaj plakasının monte edileceği duvar alanının tümü düz (herhangi bir eklem yerinin ya da duvar fayansının çıkıntısıyla) engellenmemiş, yapısı ürünü montelemeye uygun bir şekilde ve herhangi zayıf noktası olamamasını sağlamalıdır.

Kaplı vidalar ve çubuklar sadece beton için uygundur. Başka duvar yapıları için, imalatçının çubuk imal edenin belirttiği hususlar dikkate alınmalıdır.

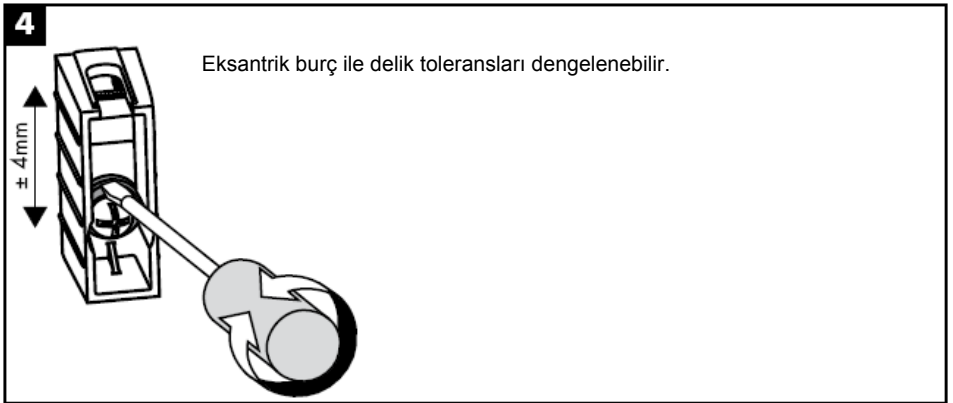
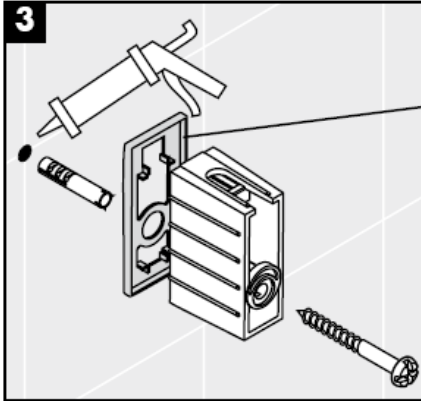
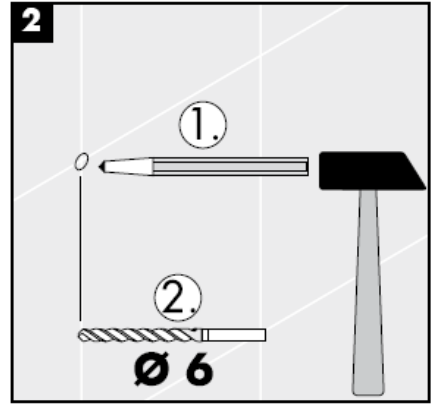
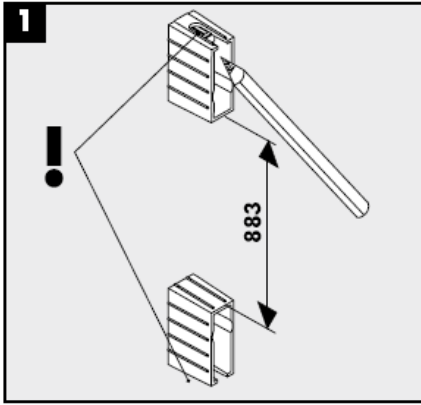

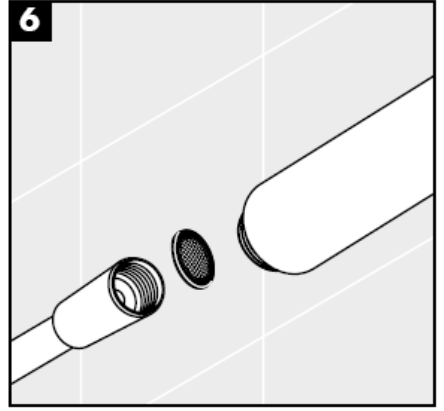
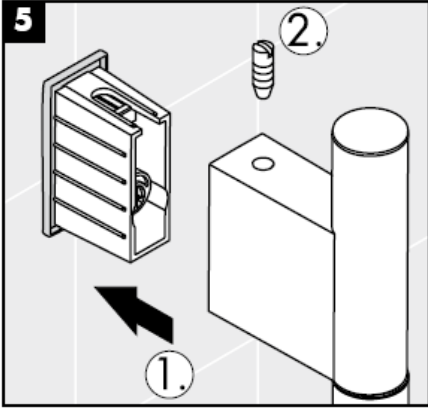

El duşu kafasına eklenmiş olan süzgeç contası, boru şebekesinden sızan kirlerin önüne geçmek için, yerine monte edilmelidir. İçeri sızan bu kirler duşun fonksiyonunu sekteleyebilir ve/veya duşun fonksiyon parçaları üzerinde hasarlara sebep olabilir, bu yüzden meydana gelen hasarlardan Hansgrohe sorumlu tutulamaz.

El duşunun norm debisini sağlamak ve şebekeden kir gelmesini önlemek için, ekteki filtre adaptörü (A) takılmalıdır. Daha büyük bir su debisi istenirse, filtre adaptörünün (A) yerine bir süzgeç contası (B) takılmalıdır. Şebekeden gelen kirler çalışmayı etkileyebilir ve/veya el duşundaki fonksiyon parçalarının zarar görmesine neden olabilir; bu nedenle oluşan hasarlar için Hansgrohe hiçbir sorumluluk üstlenmez.

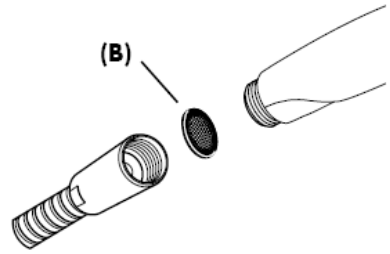
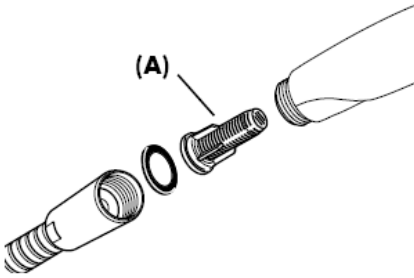

Ayarlama

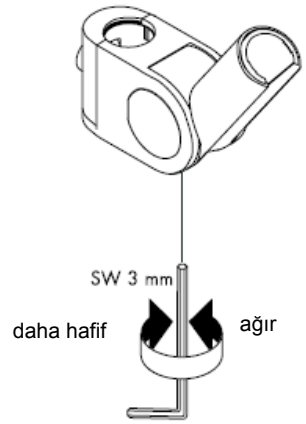
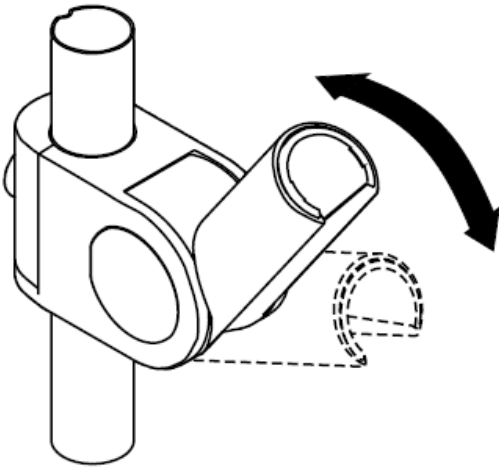
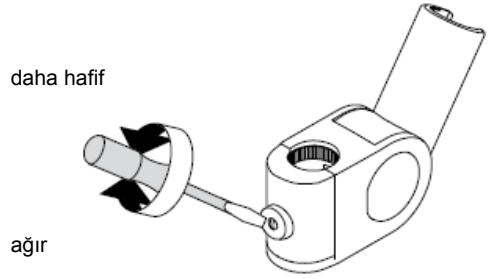
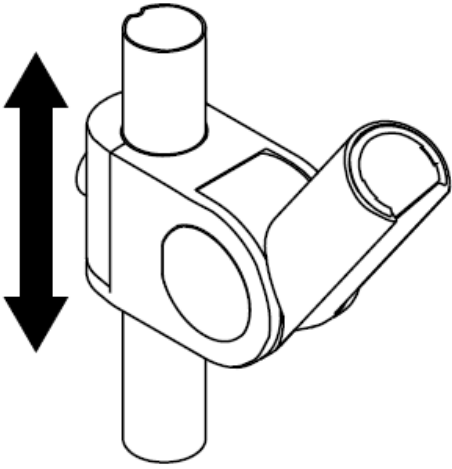

Temizleme

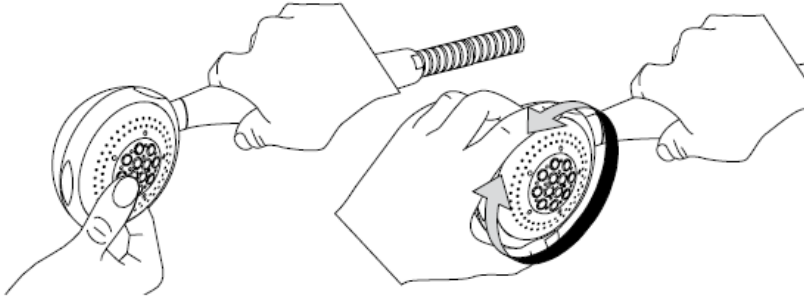

Rubit®, üründe bulunan bir temizleme fonksiyonudur. Basit bir ovuşturma ile spray modüllerdeki kireci çözer.



Bakım kılavuzu

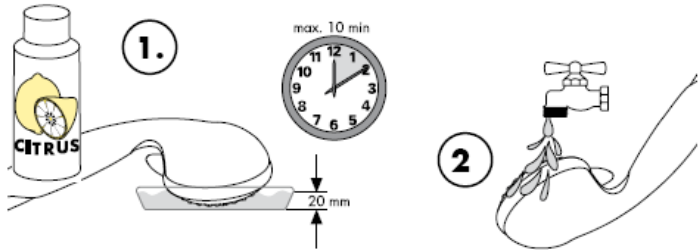

Temizleme

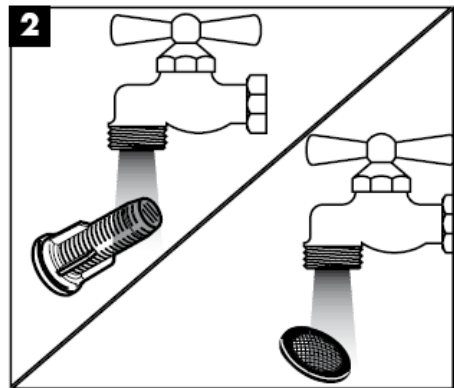
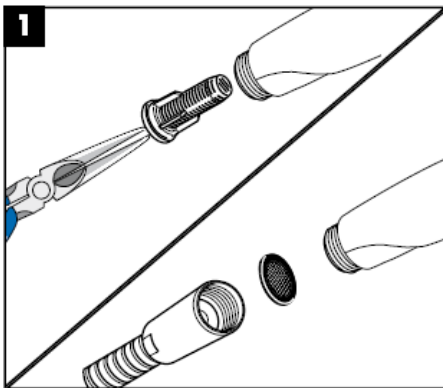
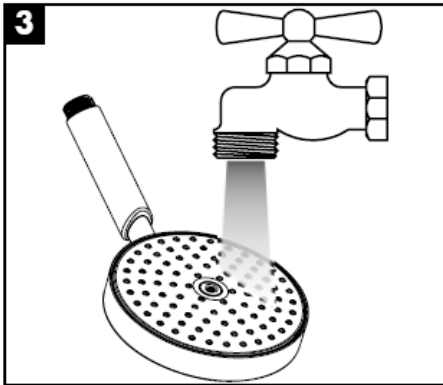
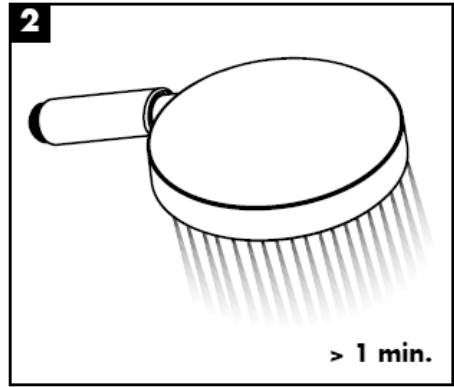
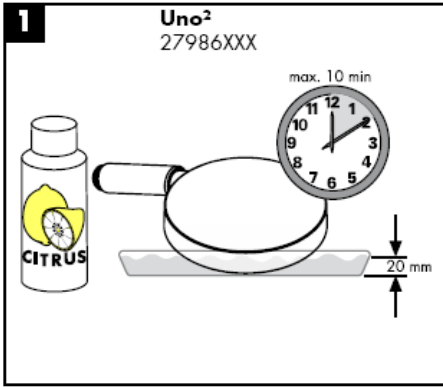

hansgrohe

Instrucțiuni de montare

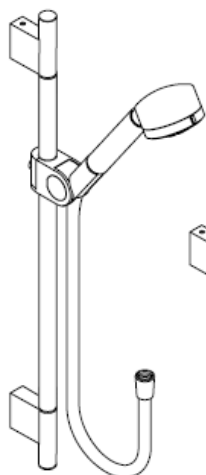

Uno/Arco
27985XXX

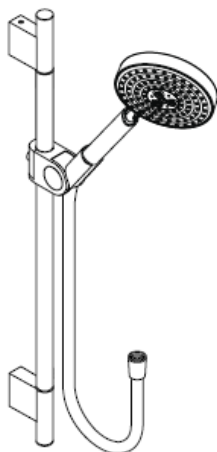

Uno²
27986XXX

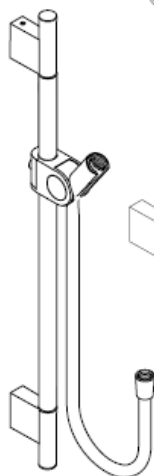

Uno
27989XXX

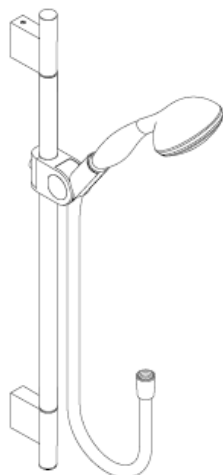

Allegroh
27956000

AXOR®

hansgrohe

Uno/Arco 27985XXX

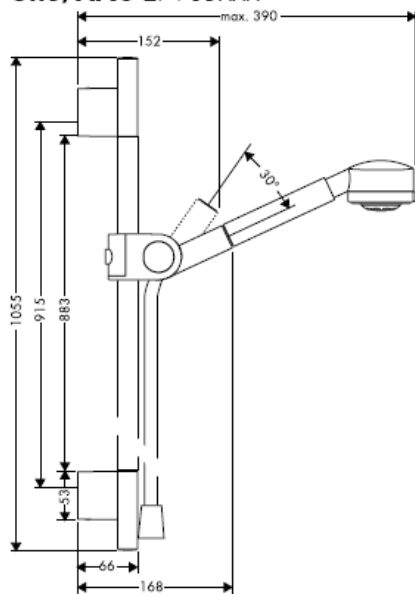

Uno² 27986XXX

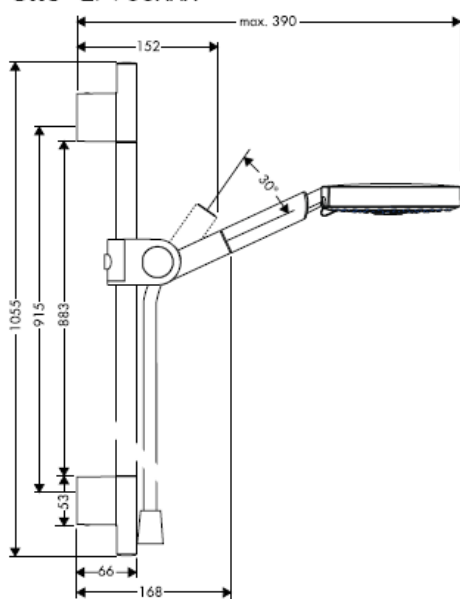

Uno 27989XXX

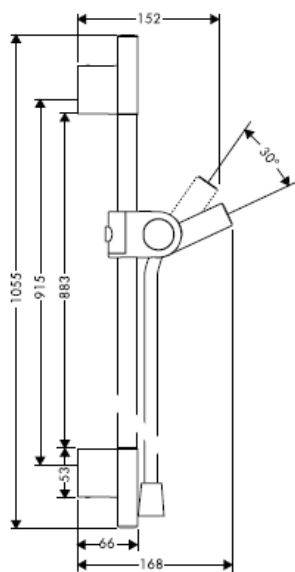

Allegroh 27956000

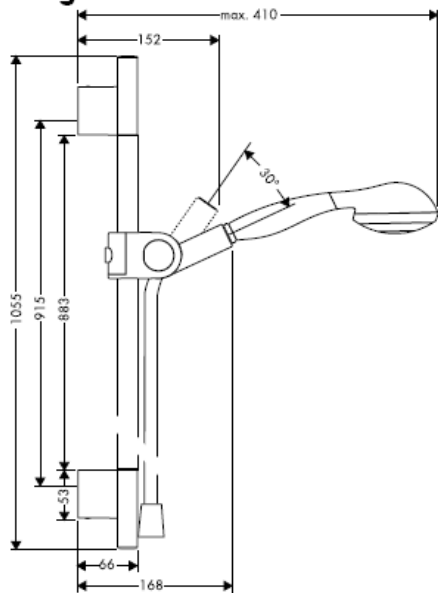



Funcționarea optimă este garantată numai când estei conectat la duș de mână și furtun de duș marca Hansgrohe. Furtunul de duș poate fi utilizat numai pentru conectarea telefonului de duș la baterie. Nu este permisă montarea unui opritor la capătul furtunului!

Date tehnice

Presiune de funcționare: max. 0,6 MPa
Presiune de funcționare recomandată: 0,1 – 0,4 MPa
(1 MPa = 10 bar = 147 PSI)
Temperatura apei calde: max. 60° C

Dușul de mână poate fi utilizat cu boiler instant de o putere de peste 21 kW și un debit de min. 7 l/min.

Uno/Arco 27985XXX

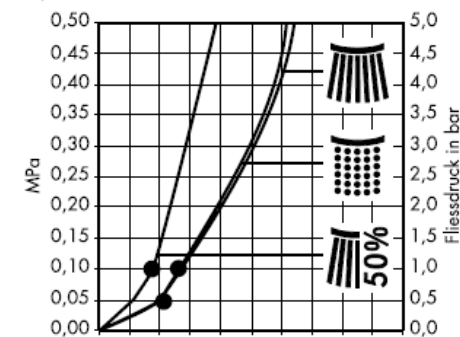
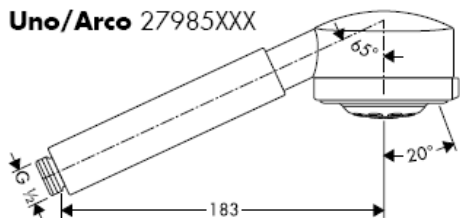

jet normal



Jet slab de apă



jet ecologic

Allegroh 27956000

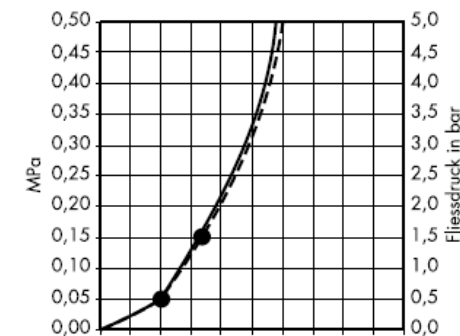
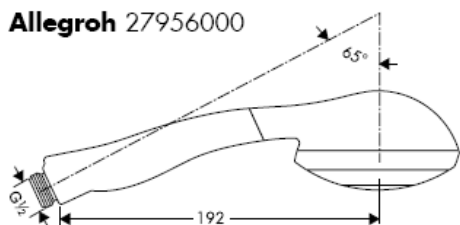

jet normal



Jet slab de apă

Uno² 27986XXX

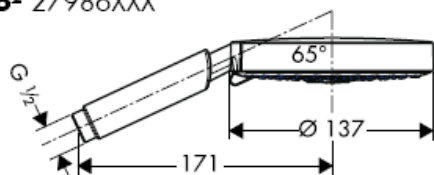

Rain AIR



Balance AIR



Whirl



Cu garnitură de filtru (A)

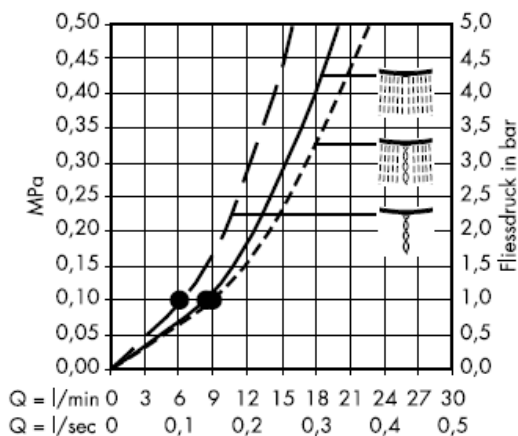

Rain AIR



Balance AIR



Whirl AIR



Cu garnitură de filtru (B)

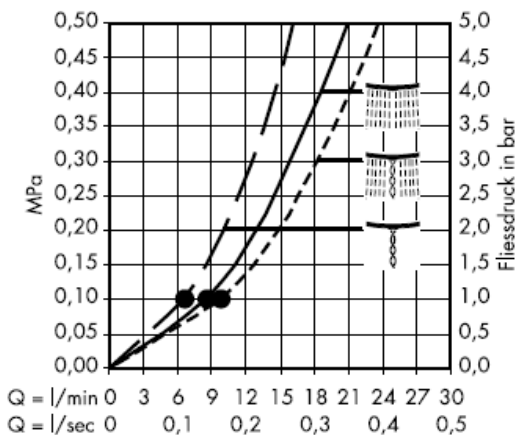

Rain AIR



Balance AIR



Whirl AIR



Începând de la • funcționarea este garantată.

Reglați dimensiunile la suprafața tencuiei.

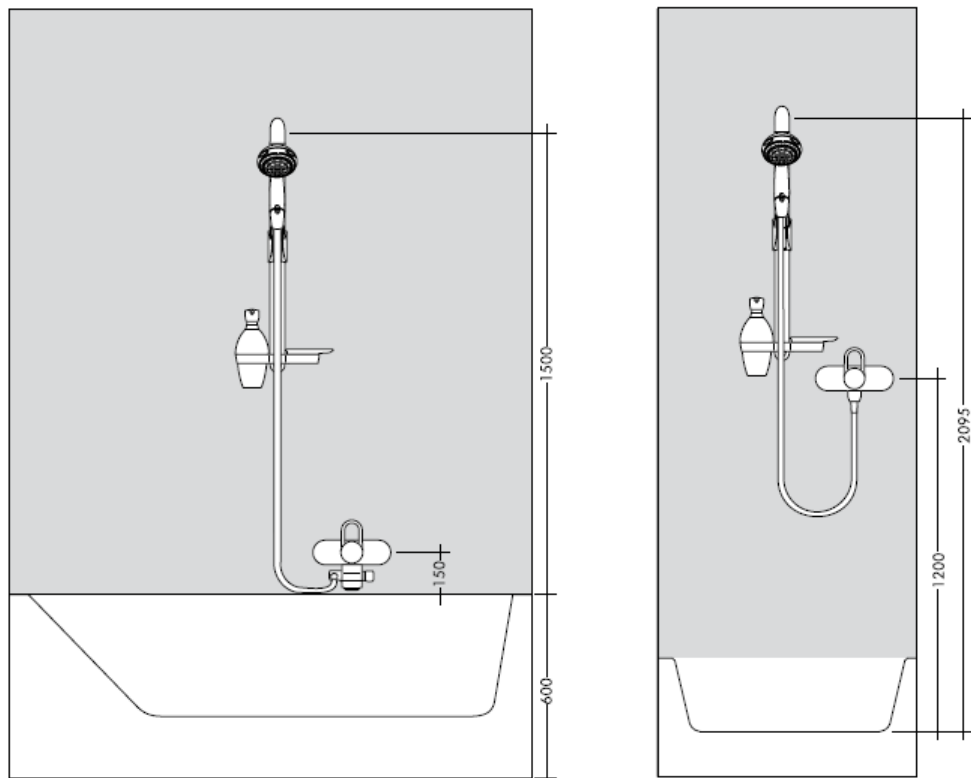

La montarea produsului de către un personal calificat trebuie să fiți atenți ca suprafața, unde se fixează produsul să fie plată pe toată suprafața utilizată (să nu existe rosturi sau faianțe proeminente), peretele să fie adecvat pentru montarea produsului și să nu există zone de rezistență redusă.

Șuruburile și diblurile livrate sunt potrivite pentru ziduri de beton. La alte tipuri de zid respectați instrucțiunile producătorului diblului utilizat.

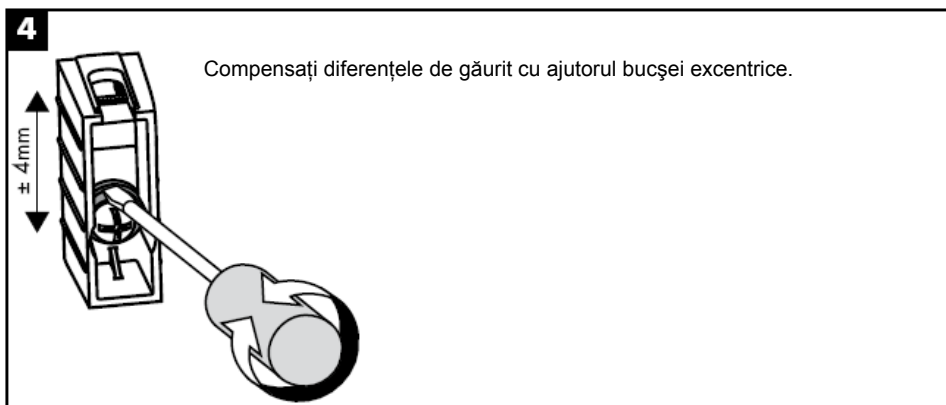
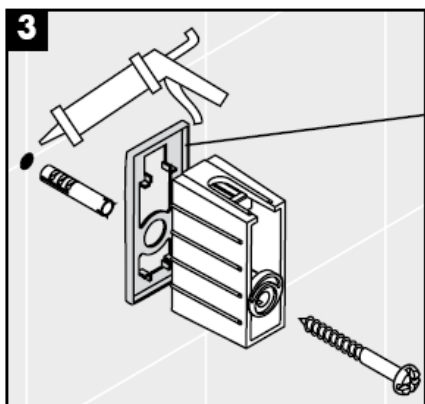
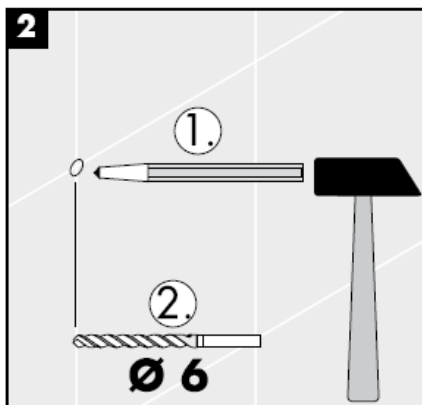
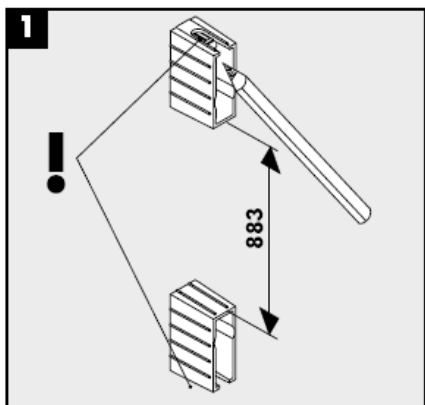

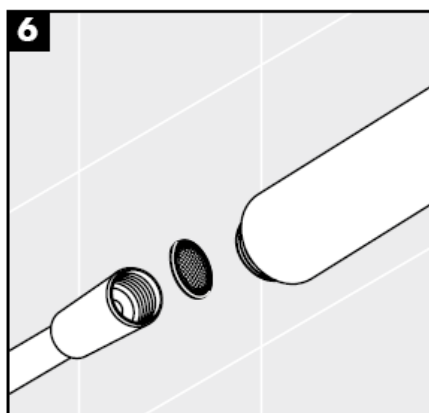
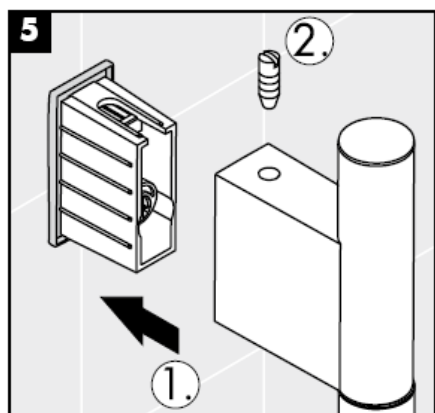

Montați garnitura de filtru livrată împreună cu capătul de duș de mână pentru evitarea pătrunderii impurităților din rețeaua de alimentare. Impuritățile pătrunse pot influența funcționarea aparatului și/sau provoca deteriorarea capătului de duș. Garanția nu acoperă aceste daune.

Montați garnitura de filtru (A) livrată cu aparatul pentru asigurarea funcționării corespunzătoare a dușului de mână și pentru evitarea pătrunderii impurităților din rețeaua de apă. Dacă doriți un debit mai mare de apă, montați garnitura sită (B) în locul garniturii de filtru (A). Impuritățile pătrunse pot influența funcționarea dușului de mână și/sau deteriora componentele acestuia, garanția nu acoperă daunele provocate din această cauză.

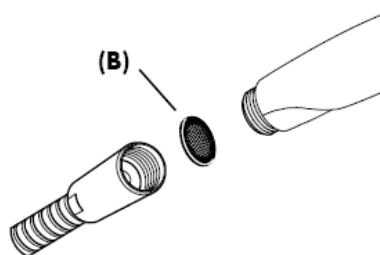
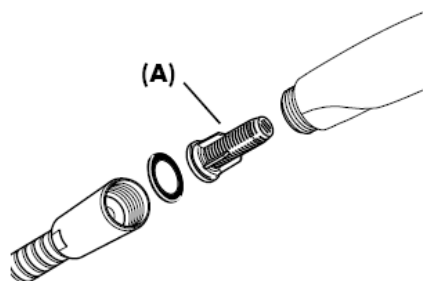

Reglare

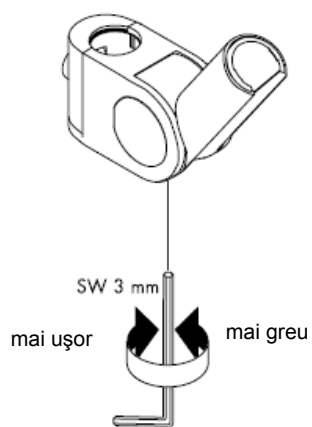
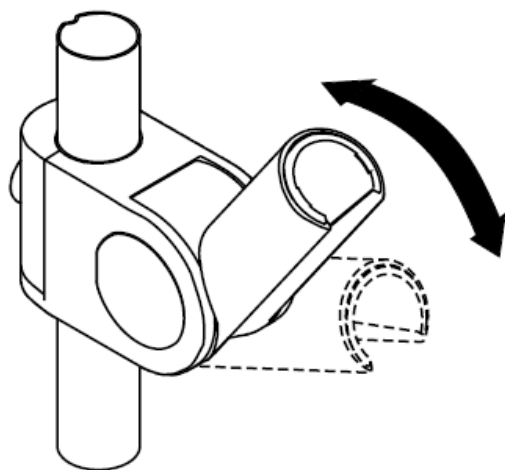
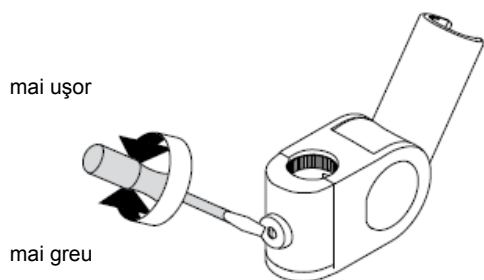
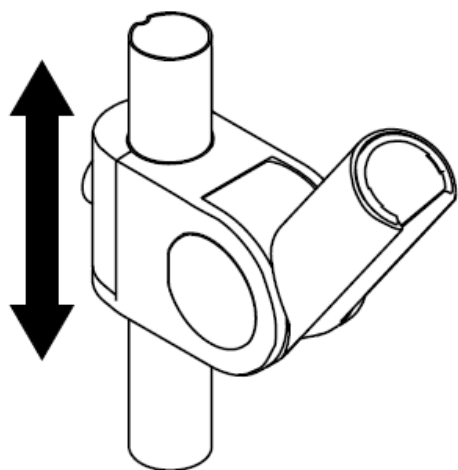

Curățare

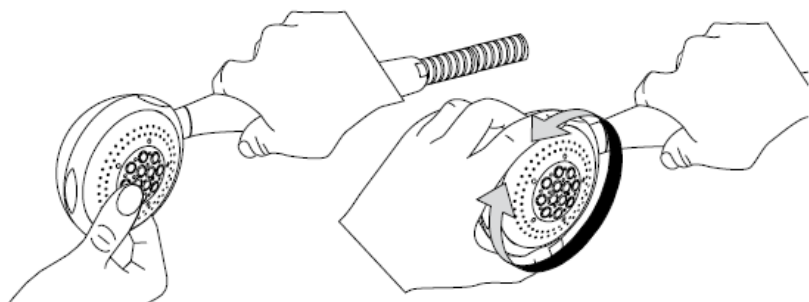

Cu ajutorul sistemului Rubit® puteți să îndepărtați depunerile de calcar de pe diferitele duze de jet de apă prin frecare.

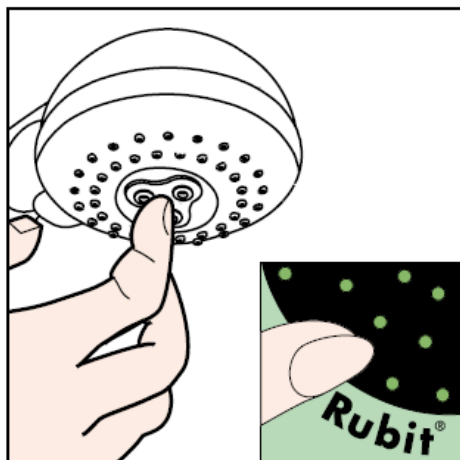

Instrucțiuni de întreținere

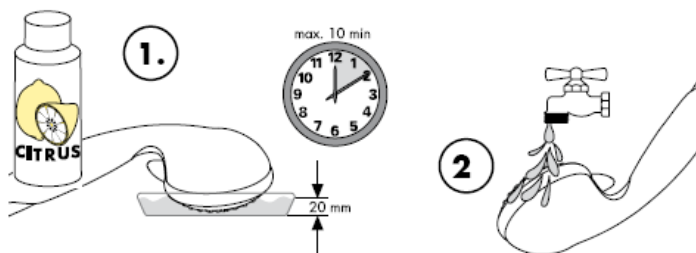

Curățare

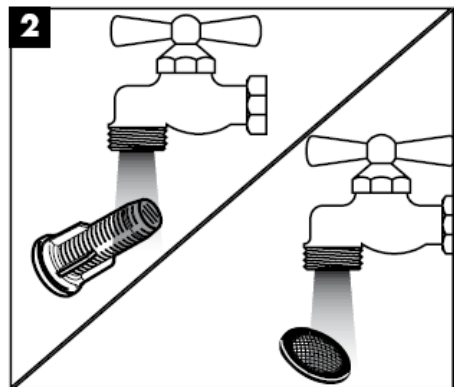
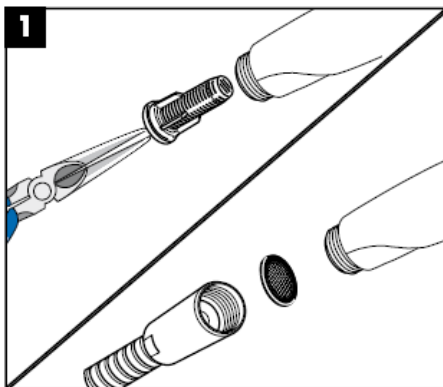
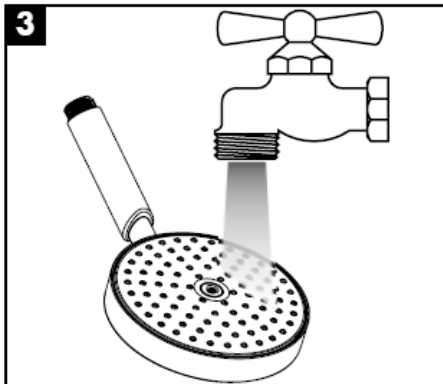
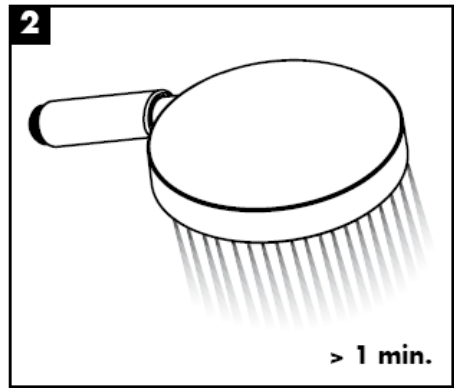
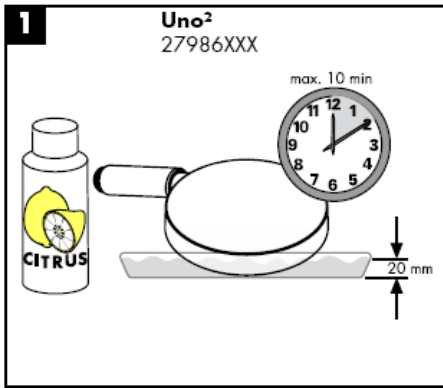

hansgrohe

Οδηγία συναρμολόγησης

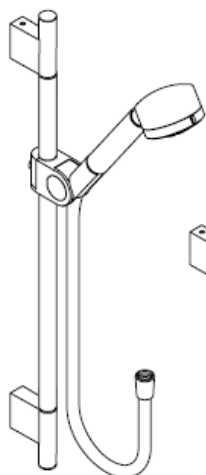

Uno/Arco
27985XXX

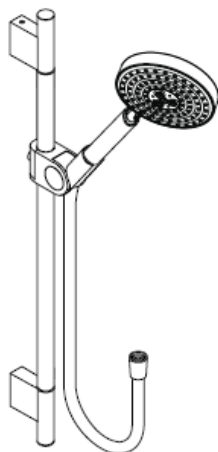

Uno²
27986XXX

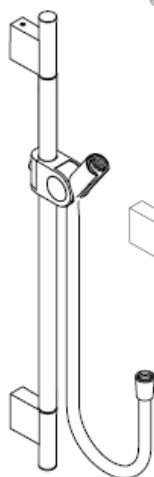

Uno
27989XXX

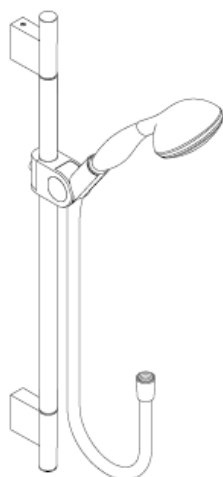

Allegroh
27956000

AXOR®

hansgrohe

Uno/Arco 27985XXX

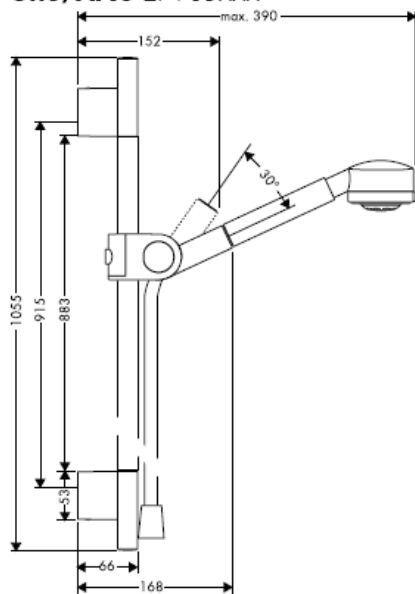

Uno² 27986XXX

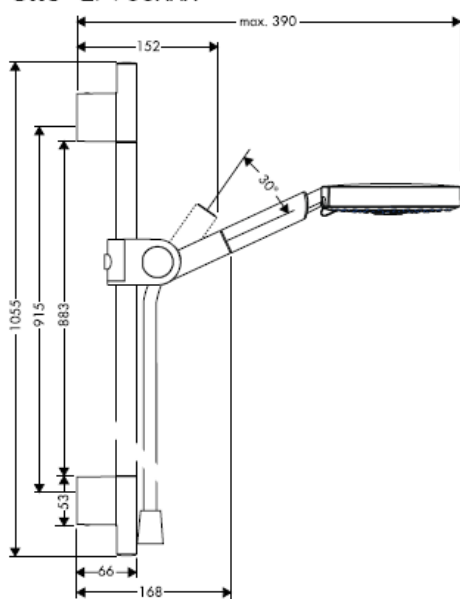

Uno 27989XXX

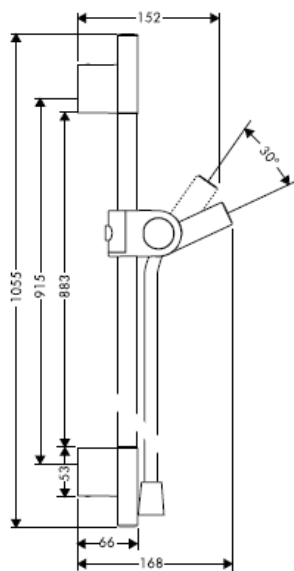

Allegroh 27956000

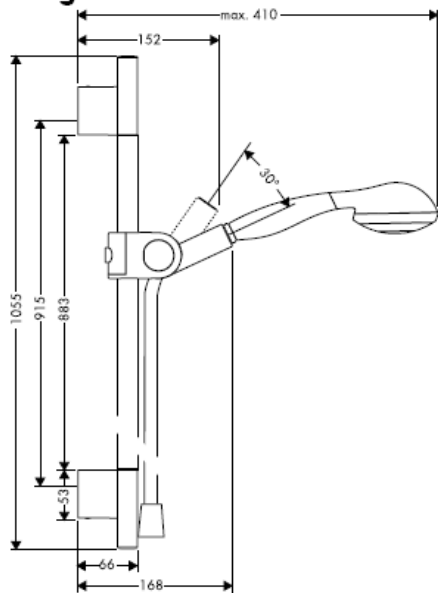



Εγγύηση βέλτιστης λειτουργίας μόνο σε συνδυασμό με καταιονιστήρα χειρός Hansgrohe και σπирάλ Hansgrohe. Το εύκαμπτο σπирάλ του καταιονιστήρα είναι κατάλληλο μόνο για τη σύνδεση του καταιονιστήρα χειρός με τη βάνα. Δεν επιτρέπεται καμία στρόφιγγα διακοπής μετά το σωλήνα στην κατεύθυνση ροής!

Τεχνικά Χαρακτηριστικά

Λειτουργία πίεσης: max. 0,6 MPa
Συνιστώμενη λειτουργία πίεσης: 0,1 – 0,4 MPa
(1 MPa = 10 bar = 147 PSI)
Θερμοκρασία ζεστού νερού: max. 60° C

Ο καταιονιστήρας χειρός είναι κατάλληλος για χρήση με ταχυθερμοσίφωνες, από μία απόδοση 21 kW και μία ελάχιστη ροή των 7L/min και άνω.

Uno/Arco 27985XXX

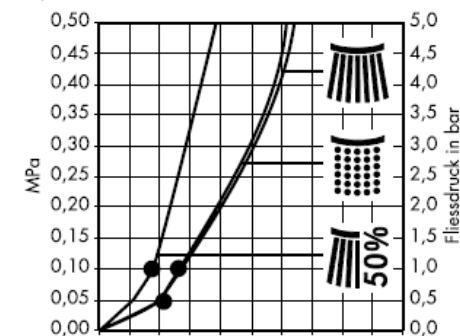
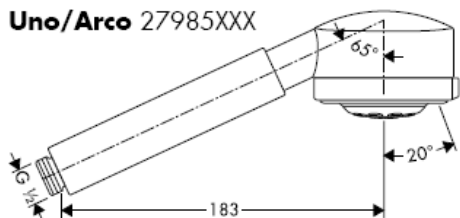

Κανονική δέσμη νερού



μαλακή δέσμη νερού



Δέσμη ECO

Allegroh 27956000

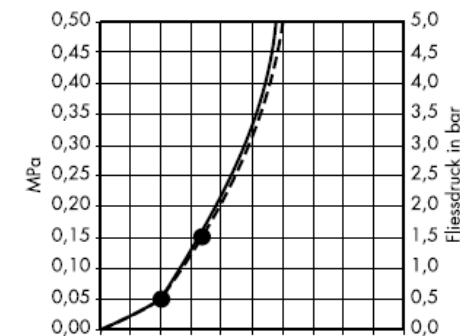
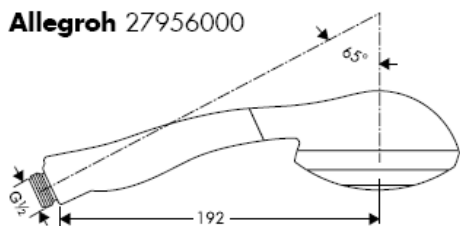

Κανονική δέσμη νερού



μαλακή δέσμη νερού

Uno² 27986XXX

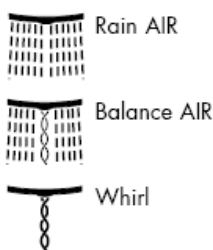
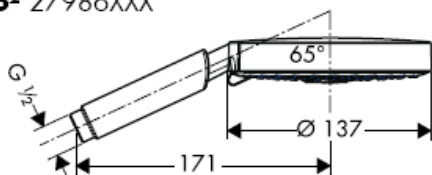

Με προσθήκη φίλτρου (A)

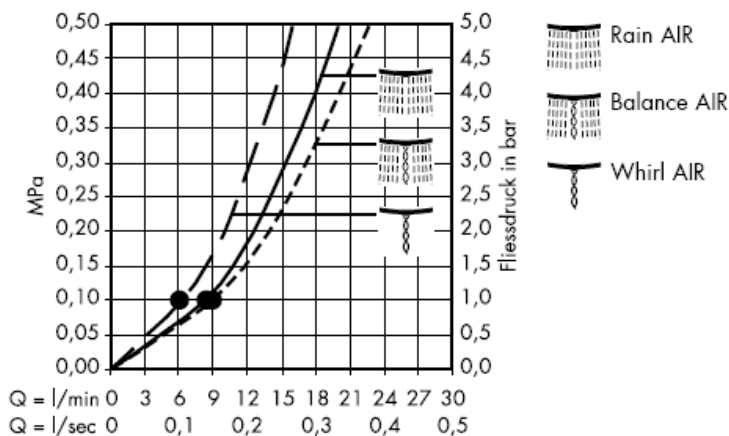

Με στεγανοποιητικό φίλτρο (B)

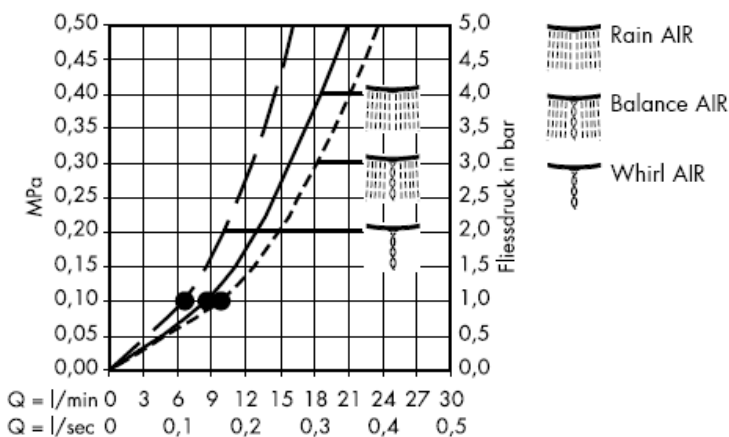

Αυτή η λειτουργία διασφαλίζεται από το σημείο κι έπειτα

Προσαρμόστε τις διαστάσεις κατά το δυνατόν στο ράστερ των πλακιδίων.

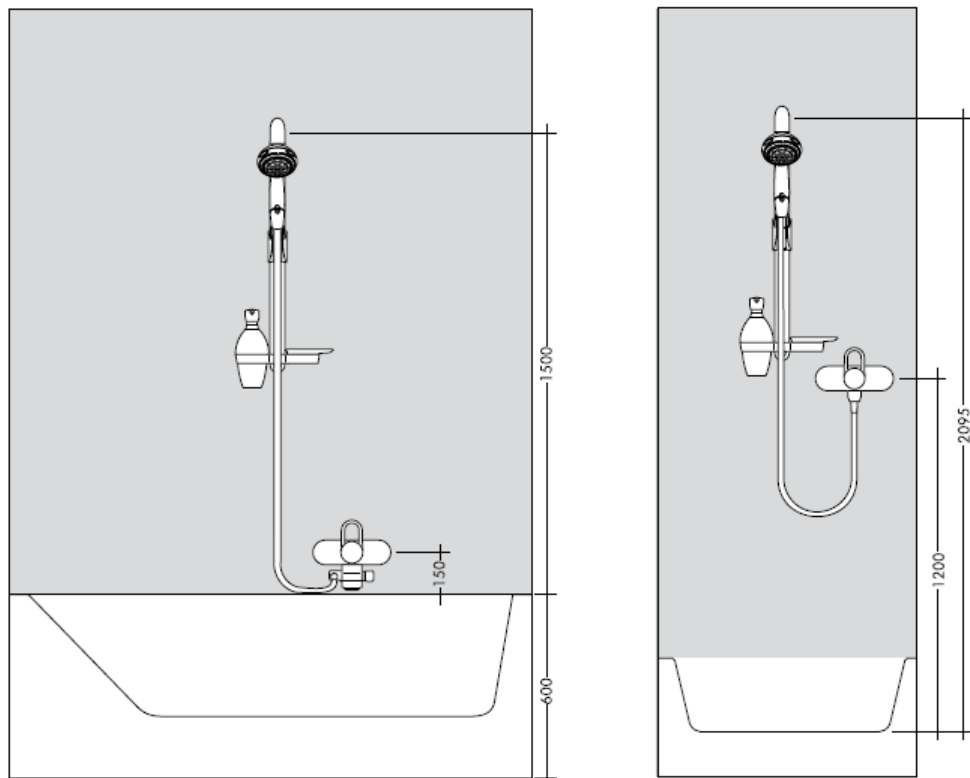

Κατά τη συναρμολόγηση του προϊόντος από καταρτισμένο και εξειδικευμένο προσωπικό θα πρέπει να δοθεί προσοχή, ώστε η επιφάνεια στερέωσης στη συνολική περιοχή στερέωσης να είναι επίπεδη (να μην υπάρχουν προεξέχοντες αρμοί ή λιθογόμωση πλακιδίων), ώστε η κατασκευή του τοίχου να είναι κατάλληλη για τη συναρμολόγηση του προϊόντος και ώστε η επιφάνεια να μην παρουσιάζει αδύναμα σημεία. Οι συνημμένες βίδες και οι στυλίσκοι ενδείκνυνται μόνο για σκυρόδεμα. Σε άλλες επίτοιχες κατασκευές θα πρέπει να δοθεί προσοχή στα δεδομένα του Κατασκευαστή των στυλίσκων.

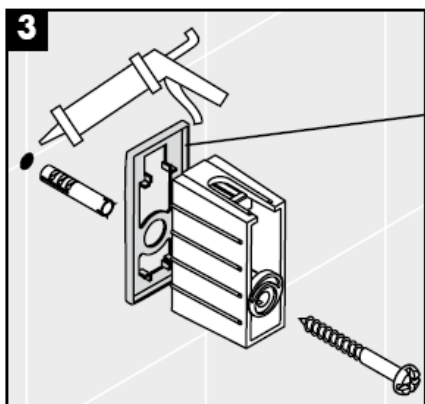
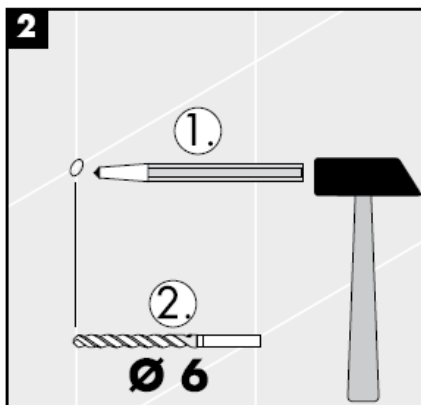
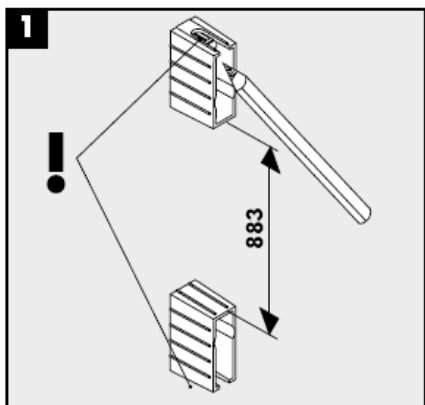

Δακτύλιος ντεκόρ μόνο σε επιχρωμιωμένη/επιχρυσωμένη παραλλαγή!

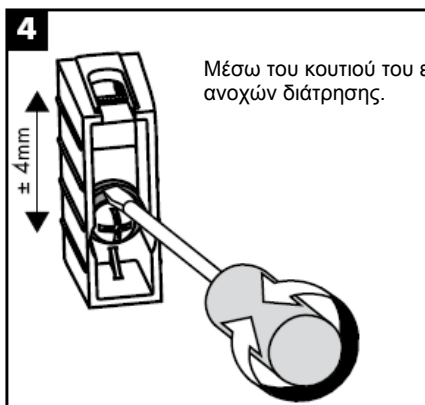

Μέσω του κουτιού του εκκέντρου είναι δυνατή η εξισορρόπηση των ανοχών διάτρησης.

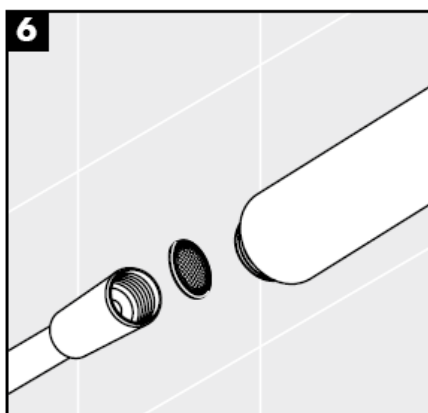
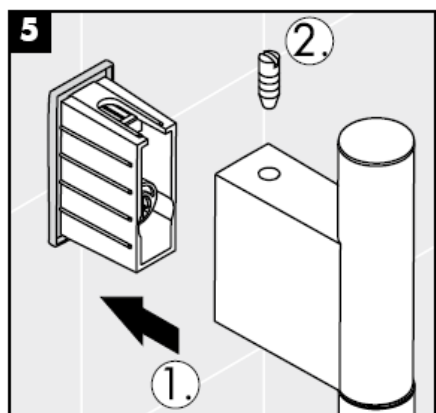

Πρέπει να εγκατασταθεί το παρέμβυσμα φίλτρου που συνοδεύει τον καταιονιστήρα κατά τέτοιο τρόπο, ώστε να αποφεύγονται ρύποι που προέρχονται από το δίκτυο ύδρευσης. Οι ρύποι από το δίκτυο ύδρευσης μπορούν να επηρεάσουν αρνητικά και/ή να προξενήσουν ζημία στα λειτουργικά τμήματα του καταιονιστήρα (ντους). Τέτοιου είδους ζημιές δεν καλύπτονται από την εγγύηση Hansgrohe.

Η συνοδευτική προσθήκη φίλτρου (A) πρέπει να εγκατασταθεί, προκειμένου να διασφαλίσει την κανονική ροή του καταιονιστήρα χειρός και να αποτρέψει την είσοδο ρύπων από το δίκτυο ύδρευσης. Εάν είναι επιθυμητή μία μεγαλύτερη ροή νερού, θα πρέπει, στη θέση της προσθήκης φίλτρου (A) να τοποθετηθεί το στεγανοποιητικό παρέμβυσμα (B). Η είσοδος ρύπων μπορεί να επηρεάσει δυσμενώς τη λειτουργία ή/και να προκαλέσει βλάβες στα λειτουργικά σημεία του καταιονιστήρα χειρός, για τις όποιες ζημιές δεν αναλαμβάνει καμία ευθύνη η εταιρεία Hansgrohe.

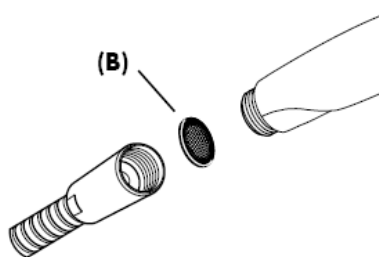
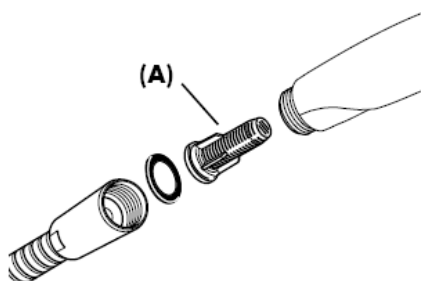

Ρύθμιση

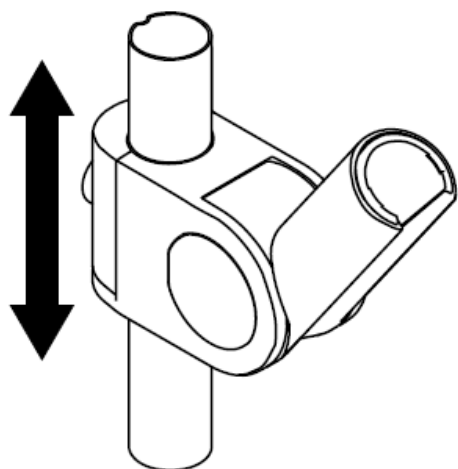

ευκολότερα

βαρύτερα

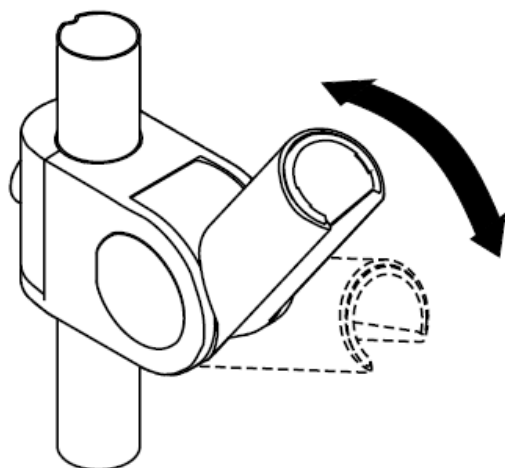
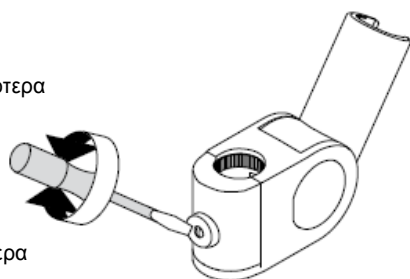

ευκολότερα

βαρύτερα

SW 3 mm

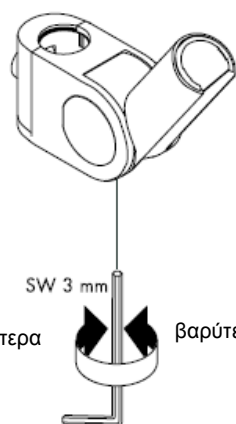

Καθαρισμός

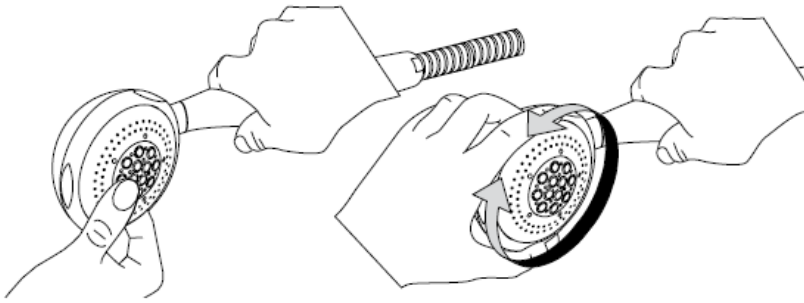

Με Rubit®, τη λειτουργία καθαρισμού με το χέρι, μπορούν να απομακρυνθούν με απλό τρίψιμο τα άλατα από τα κανάλια του καταιονιστήρα.



Οδηγία συντήρησης

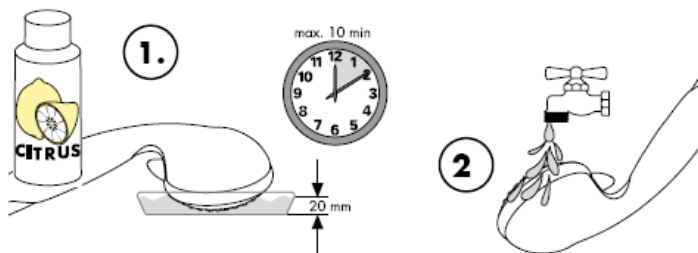

Καθαρισμός

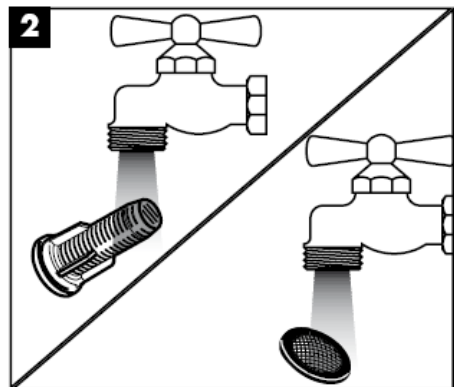
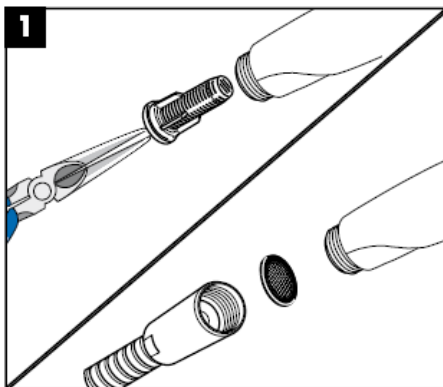
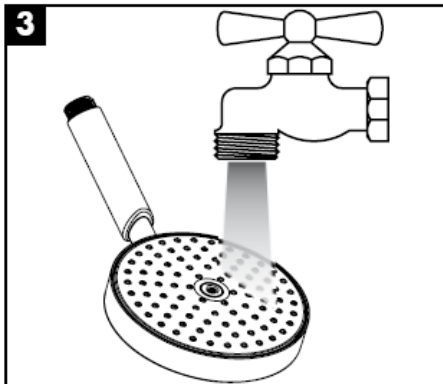
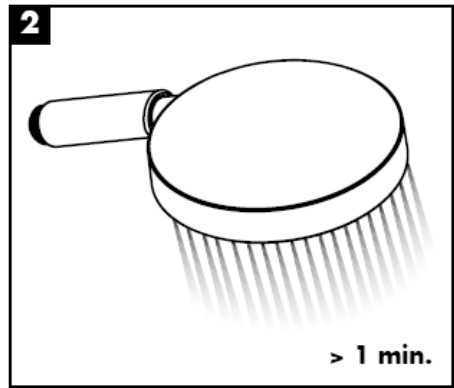
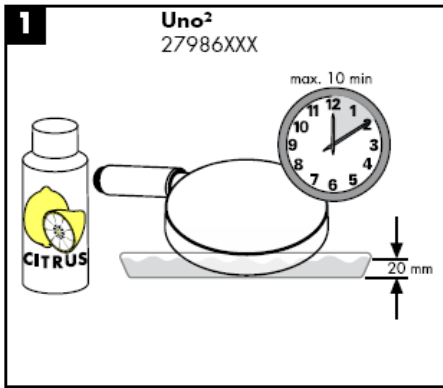

hansgrohe

تعليمات التجميع

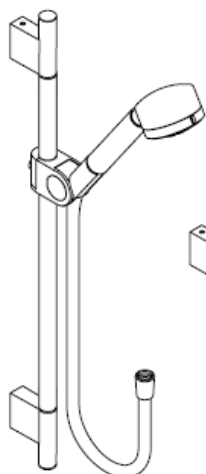

Uno/Arco
27985XXX

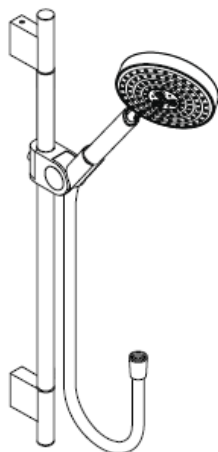

Uno²
27986XXX

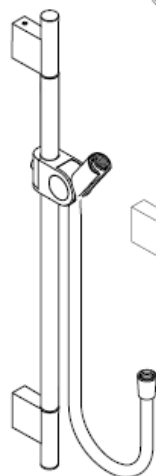

Uno
27989XXX

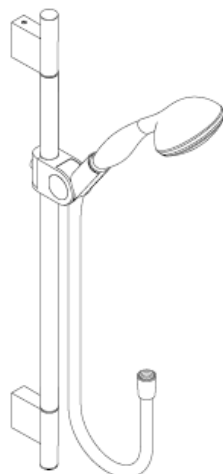

Allegroh
27956000

AXOR®

hansgrohe

Uno/Arco 27985XXX

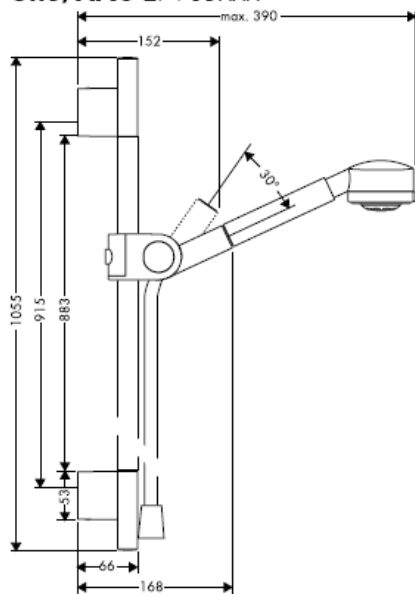

Uno² 27986XXX

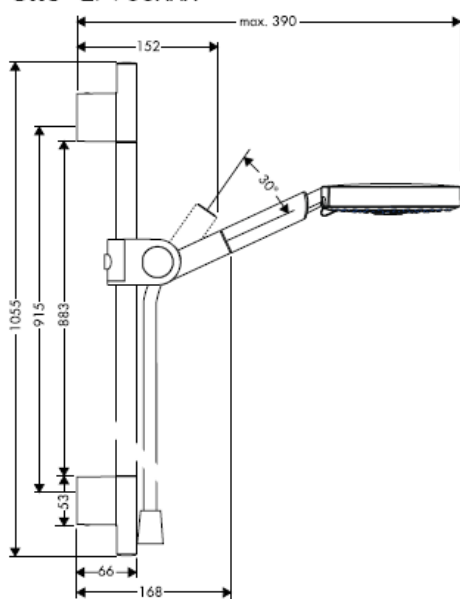

Uno 27989XXX

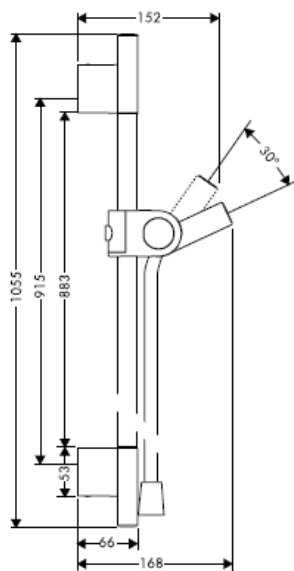

Allegroh 27956000

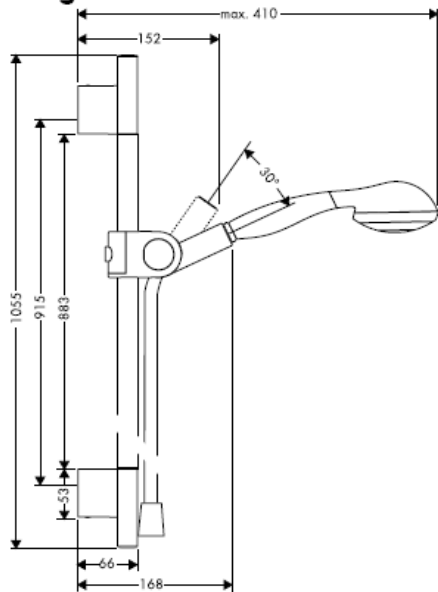



لا يمكن ضمان الحصول على الأداء الأمثل إلا من خلال الجمع بين الدش اليدوي إنتاج هانزجرروه وخراطيم الدش إنتاج هانزجرروه. لا تصلح خراطيم الدش إلا للتوصيل من الدش إلى الوصلة. حذار من تركيب جهاز إغلاق بين الوصلة والخرطوم.

المواصفات الفنية

ضغط التشغيل: max. 0,6 MPa
ضغط التشغيل الموصى به: 0,1 – 0,4 MPa
(1 PSI = 0,07 MPa = 1 بار)
درجة حرارة الماء الساخن: max. 60° C

يصلح الدش اليدوي للاستخدام مع سخانات المياه ذات التدفق المستمر التي يبلغ خرج الحرارة منها 21 كيلو وات وحد أدنى من التدفق المار بها يبلغ 7 لتر / الدقيقة.

Uno/Arco 27985XXX

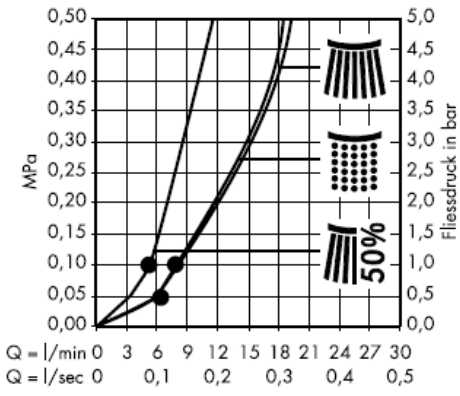
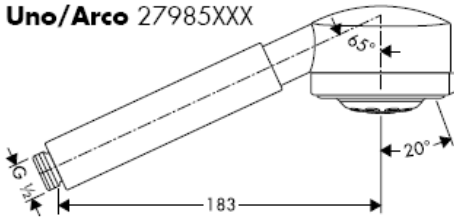

-  رشاش عادي
-  رشاش مرن
-  تيار التدليك 50%

Allegroh 27956000

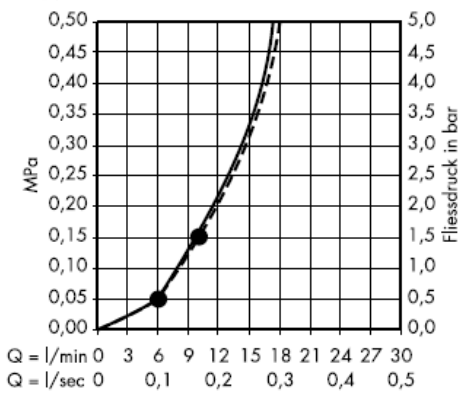
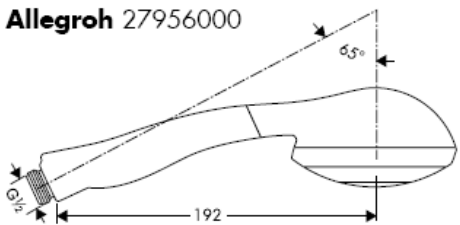

-  رشاش عادي
-  رشاش مرن

Uno² 27986XXX

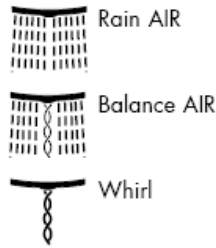
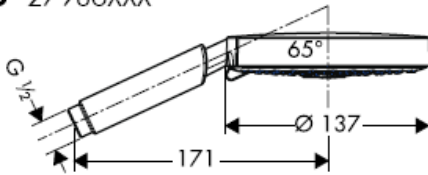

بوليجة المرشح (A)

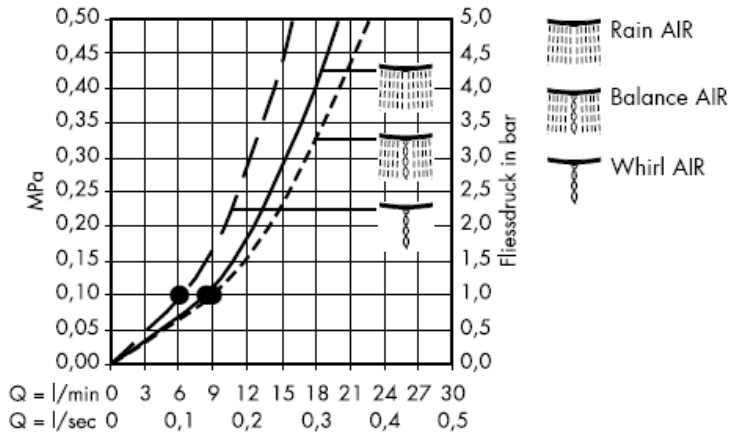

مع أجزاء المرشح (B)

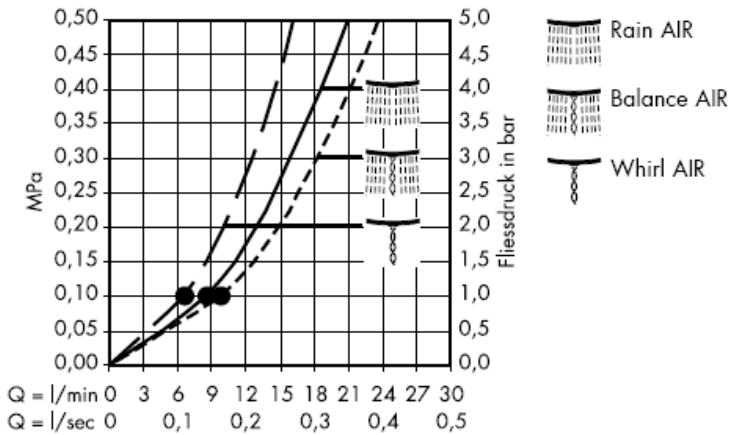

من • الوظيفة مضمونة.

قم بضبط الأبعاد حسب شكل البلاط إذا لزم الأمر.

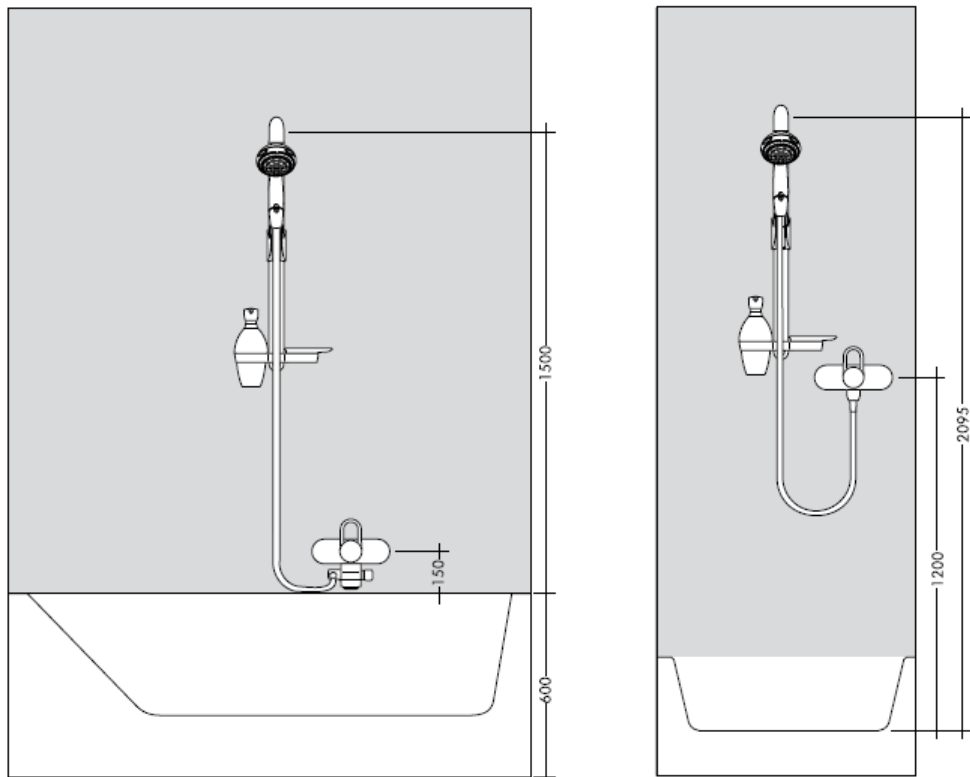

يجب الانتباه عند تركيب المنتج بواسطة فريق العمل المتخصص إلى أن جميع مواضع التثبيت جاهزة للتثبيت دون عوائق (خالية من المفصلات أو الملمصقات)، وأن الحائط جاهز لتركيب المنتج مع عدم احتوائه على أية أماكن ضعيفة، مبيئات المسامير (الفيشر) والمسامير نفسها مناسبة للحوائط الخرسانية فقط، ويجب الالتزام بتعليمات الجهة المصنعة لمبيئات المسامير عند التثبيت في أنواع أخرى من الحوائط.

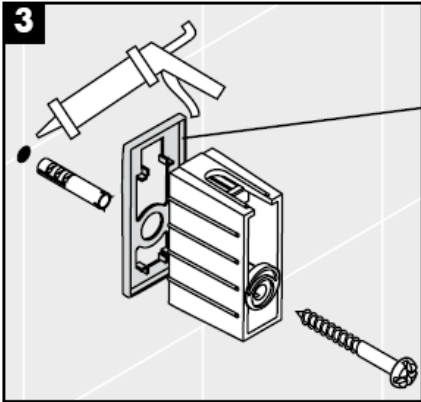
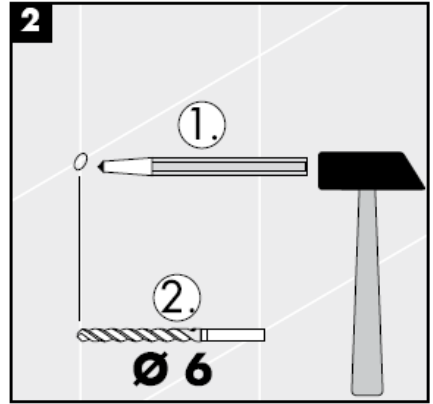
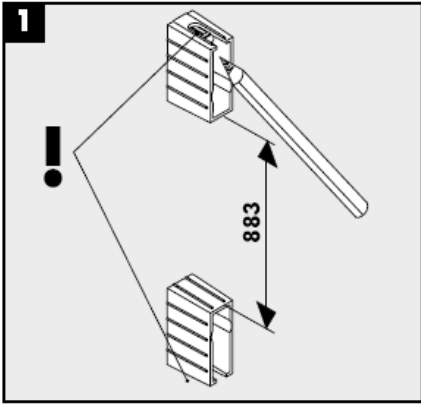

تستخدم الحلقة الزخرفية فقط للأغراض المصنوعة من الكروم/الذهب!

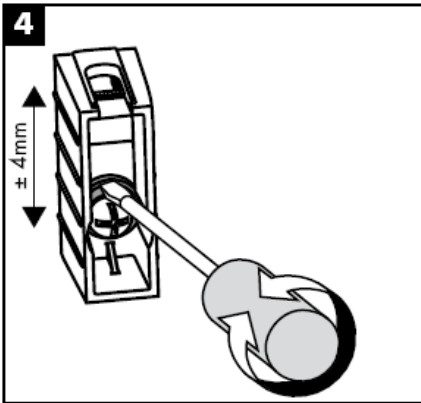

باستخدام الحلقة اللامركزية يمكن معادلة خلوص الثقب.

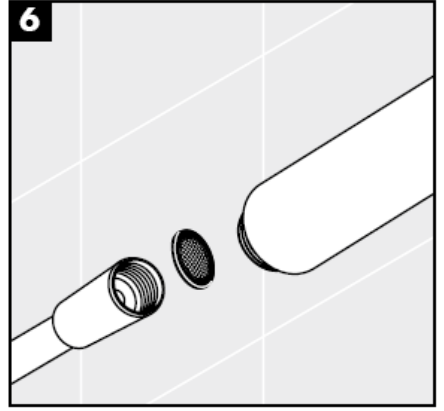
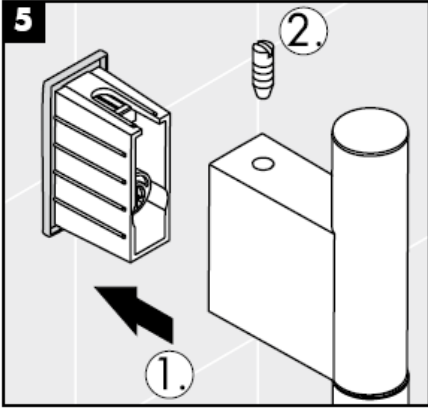

يجب إدخال الحلقة الشبكية لحماية الدش اليدوي من الأوساخ التي تحملها شبكة المواسير. حيث تؤدي الأوساخ الواردة إلى حدوث أعطال أو / وقد تتسبب في تلف أجزاء من من الدش، ومثل هذه الأعطال تلغي كافة المطالبات الخاصة بالمسؤولية أو الضمان.

يجب استخدام وليجة المرشح (A) لضمان الحصول على معدل التدفق القياسي وحماية الدش اليدوي من الأوساخ التي تحملها شبكة المواسير. هل تريد الحصول على معدل تدفق أعلى؟ إذن يجب أن تستخدم حشوية المرشح (B) بدلاً من وليجة المرشح (A). حيث تؤدي الأوساخ الواردة إلى حدوث أعطال أو / وقد تتسبب في تلف أجزاء من من الدش اليدوي، ومثل هذه الأعطال تلغي كافة المطالبات الخاصة بالمسؤولية أو الضمان.

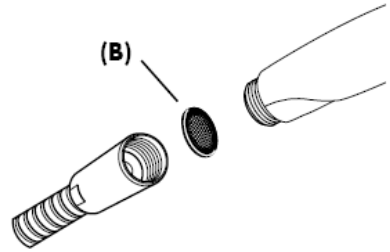
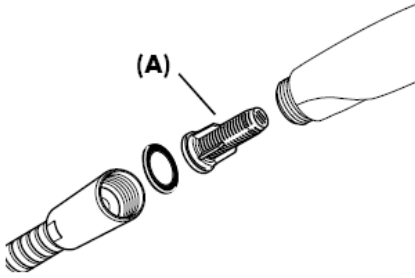

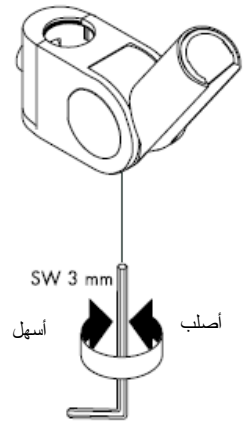
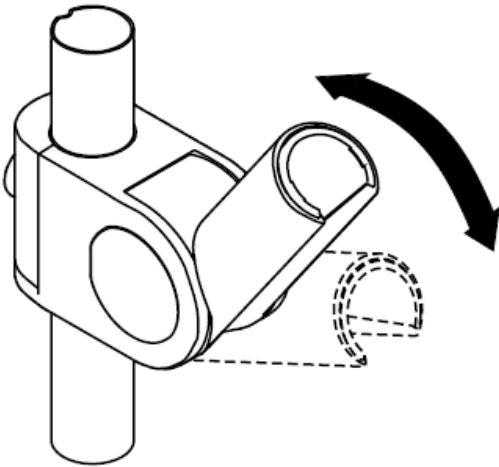
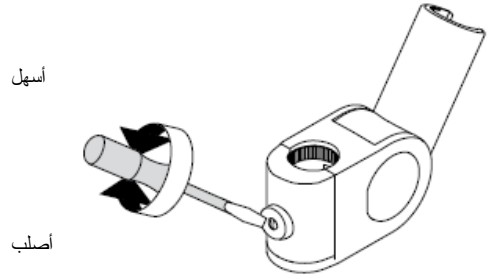
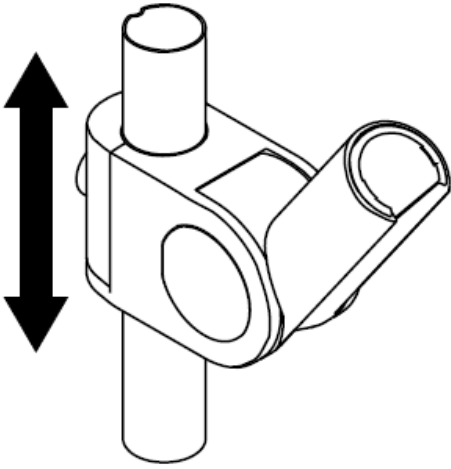

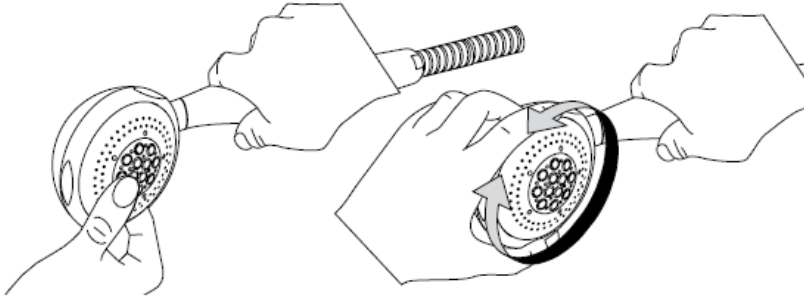

لا تحتاج وظيفة تنظيف سوى قدر بسيط من الفرك باليد لإزالة القشور الجيرية من قنوات الرشاش.



تعليمات التنظيف

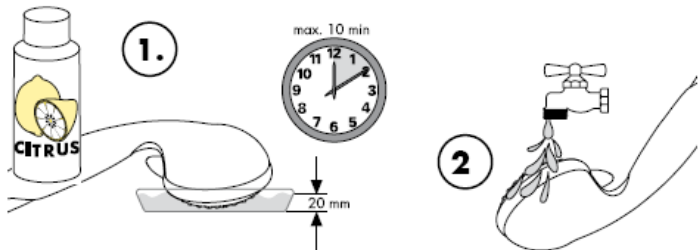

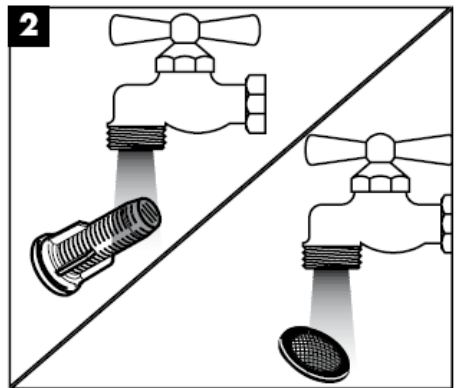
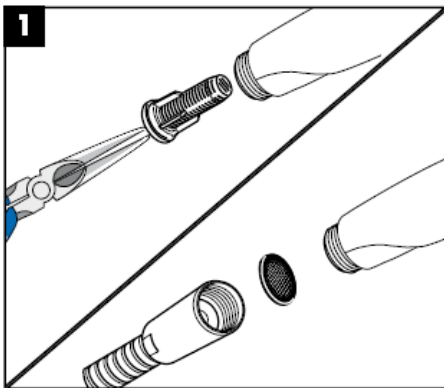
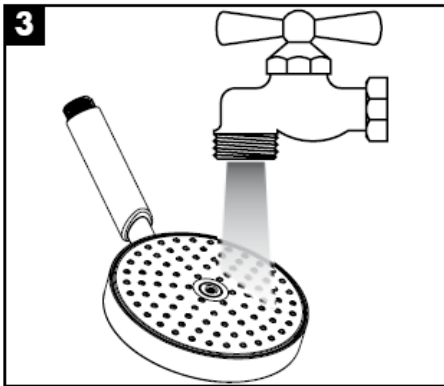
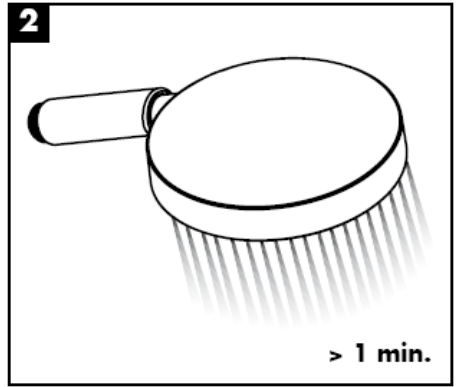
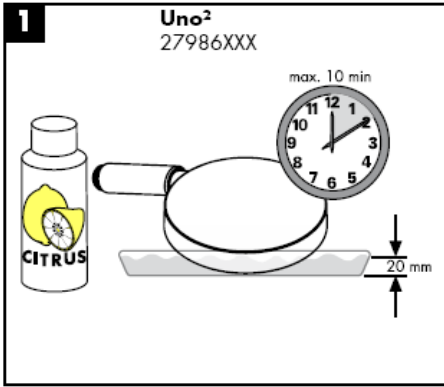

hansgrohe

Navodila za montažo

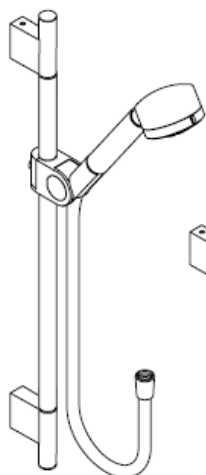

Uno/Arco
27985XXX

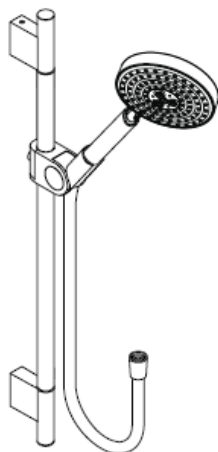

Uno²
27986XXX

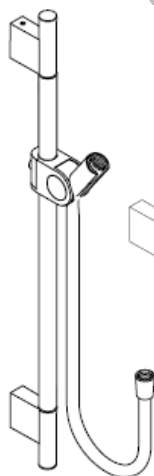

Uno
27989XXX

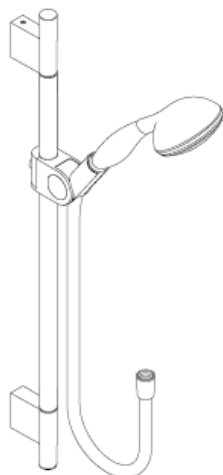

Allegroh
27956000

AXOR®

hansgrohe

Uno/Arco 27985XXX

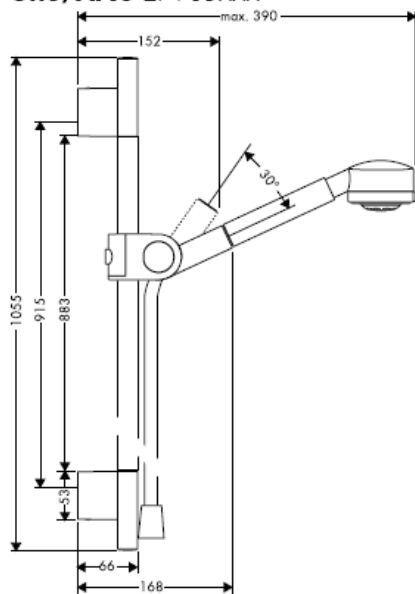

Uno² 27986XXX

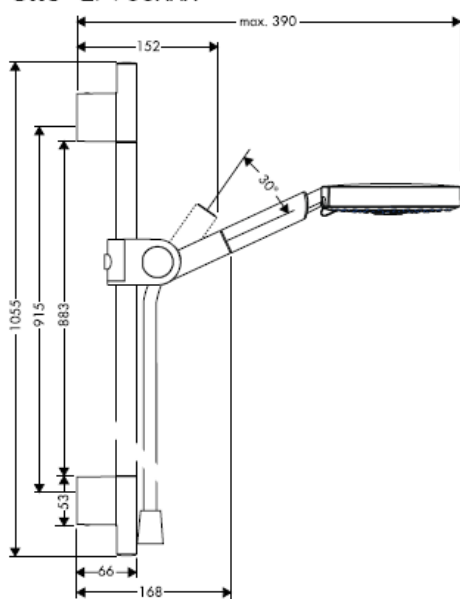

Uno 27989XXX

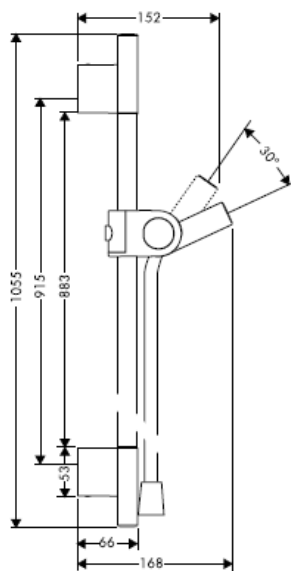

Allegroh 27956000

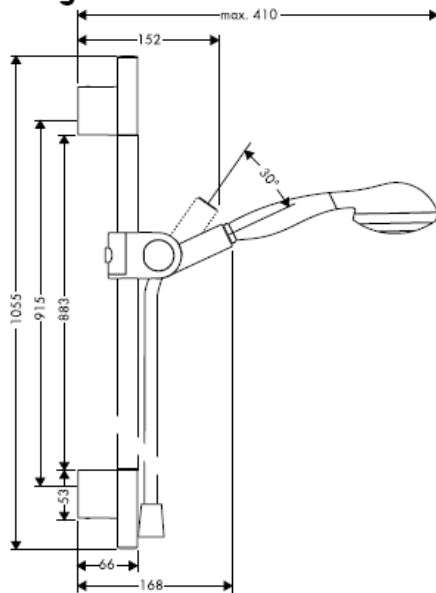



Optimalno delovanje je zagotovljeno le v povezavi z ročnimi prhami Hansgrohe in gibkimi cevmi za prho Hansgrohe. Gibke cevi za prho so primerne le za povezavo prhe in armature. Naprave za zapiranje pretoka vode nikoli ne nameščajte med armaturo in cev.

Tehnični podatki

Delovni tlak:	max. 0,6 MPa
Priporočeni delovni tlak: (1 MPa = 10 bar = 147 PSI)	0,1 – 0,4 MPa
Temperatura tople vode:	max. 60° C

Ročna prha je primerna za uporabo s pretočnimi grelniki zmogljivosti nad 21 kW in minimalnim pretokom 7 l/min.

Uno/Arco 27985XXX

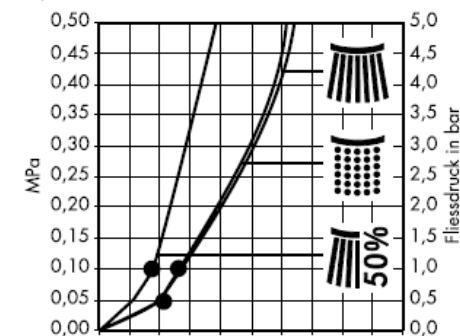
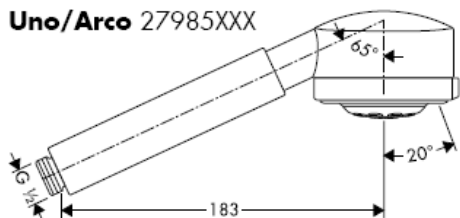

Normalen curek



Mehki curek



Ekocurek

Allegroh 27956000

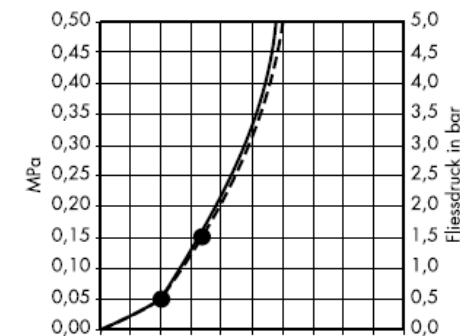
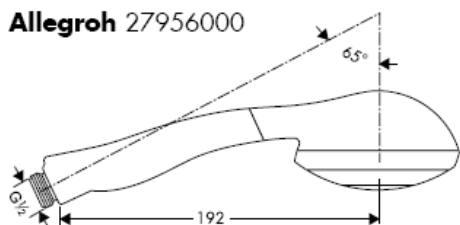

Normalen curek



Mehki curek

Uno² 27986XXX

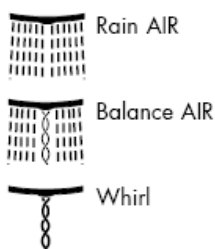
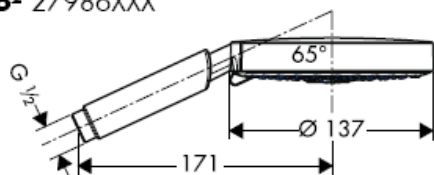

S filtrirnim vložkom (A)

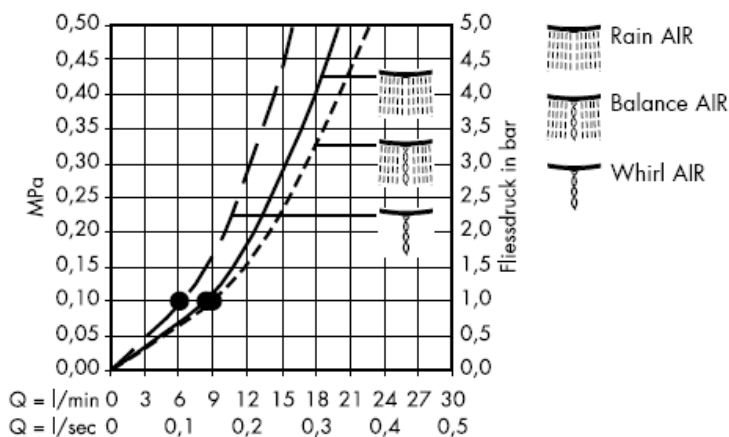

S filtrino mrežico (B)

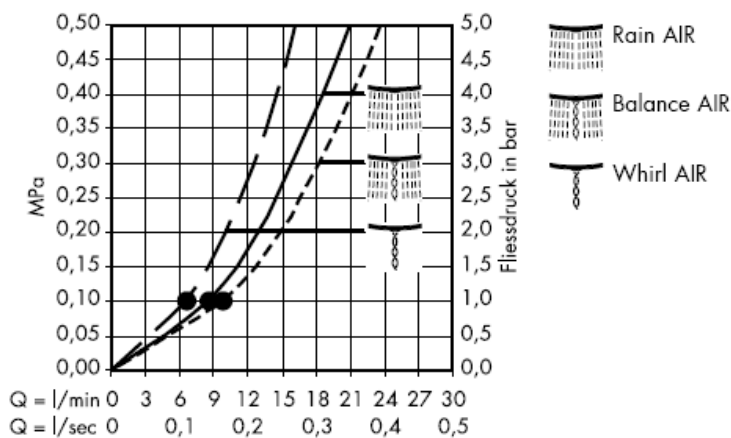

Od • je delovanje zagotovljeno.

Mere kar najbolj prilagodite vzorcu ploščic.

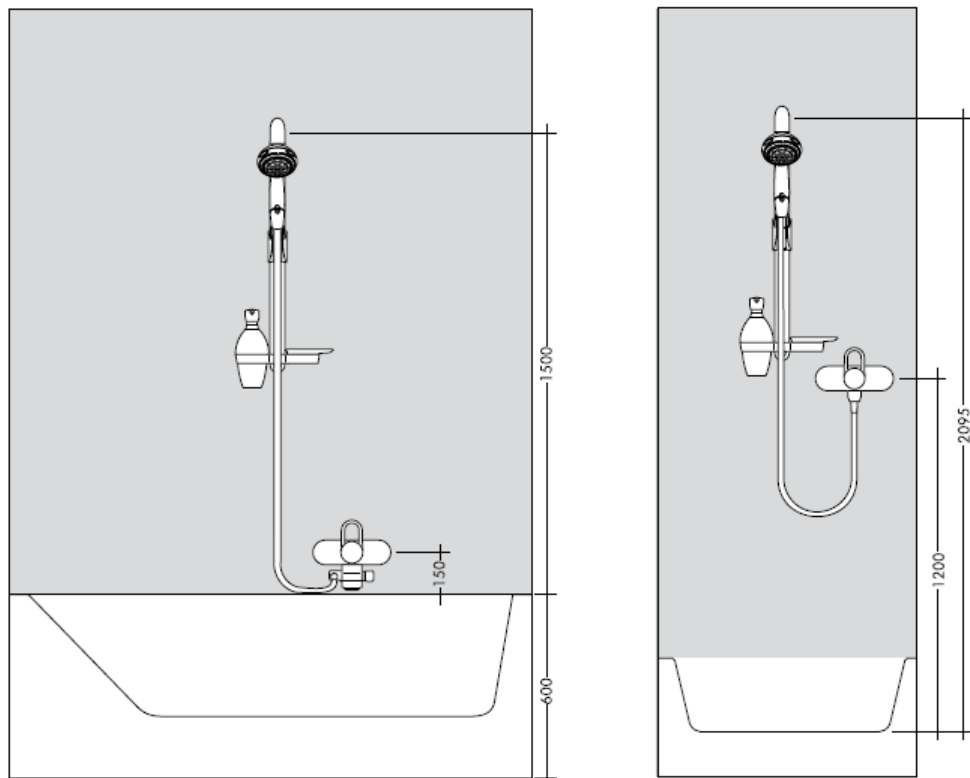

Kamorkoli bo pogodbenik namestil izdelek, mora poskrbeti, da je celotno območje stene na katero bo plošča nameščena ravno (brez štrlečih fug ali robov ploščic), ter da je struktura stene primerna za namestitev in je brez šibkih točk.

Priloženi vijaki in ležaji so primerni le za beton. Za ostale zidne konstrukcije je potrebno upoštevati proizvajalčeva navodila.

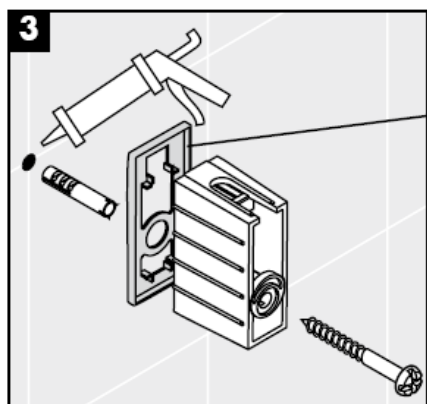
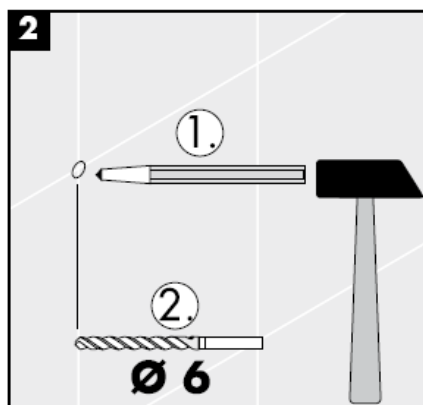
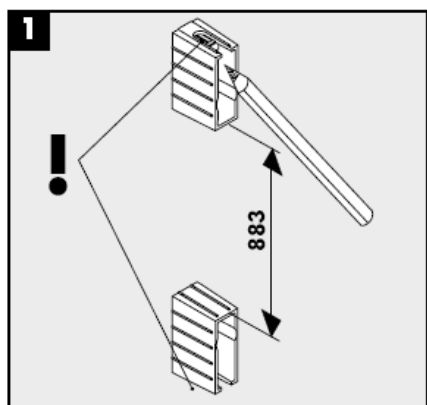

Okrasni obroč le pri kromirani/pozlačeni različici!

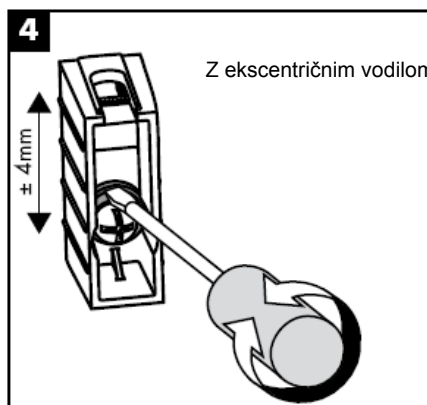

Z ekscentričnim vodilom lahko izravnate tolerance vrtanja.

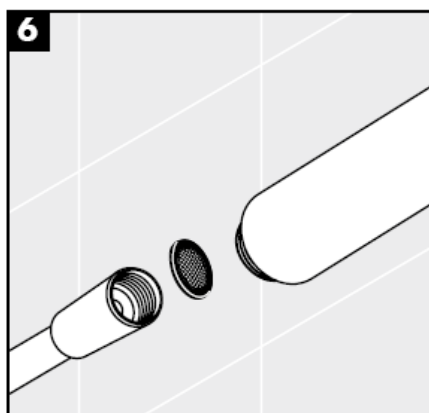
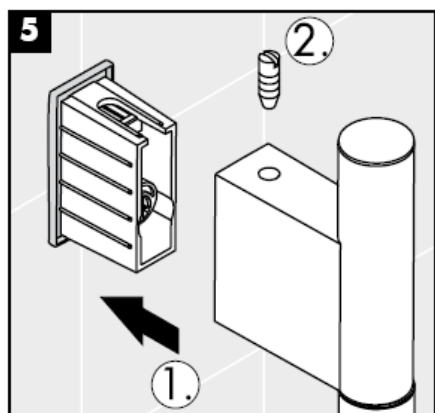

Filter, ki je priložen ročni prhi, je potrebno vgraditi, da prho zaščitimo pred umazanijo iz vodovodne napeljave. Umazanija lahko okvari ali poškoduje dele ročne prhe. Za tako nastalo škodo Hansgrohe ne odgovarja.

Priloženi filtrirni vložek (A) je potrebno vgraditi, da zagotovimo standardni pretok in zaščitimo ročno prho pred umazanijo iz vodovodne napeljave. Če želite večji pretok vode, je namesto filtrirnega vložka (A) potrebno vstaviti filtrirno mrežico (B). Umazanija lahko okvari ali poškoduje dele ročne prhe. Za tako nastalo škodo Hansgrohe ne odgovarja.

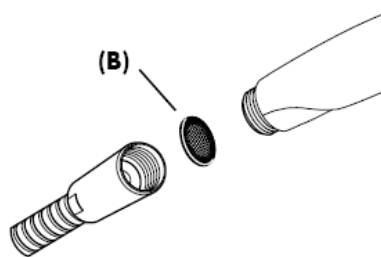
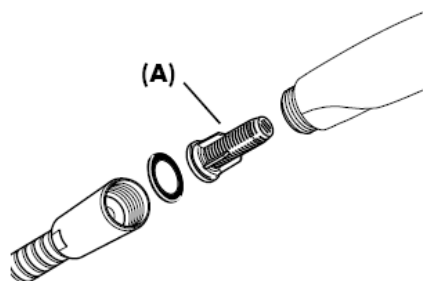

Nastavitev

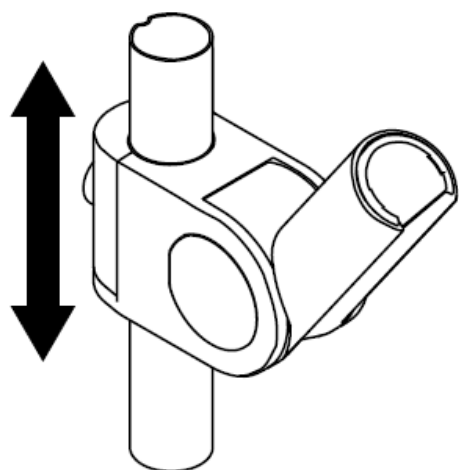

lažje

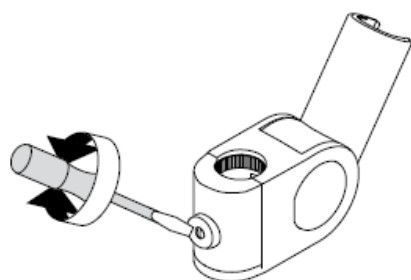

težje

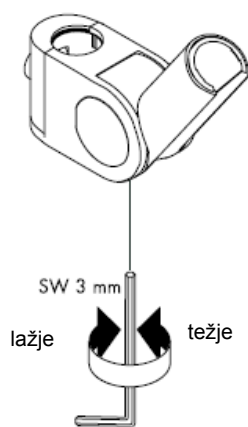
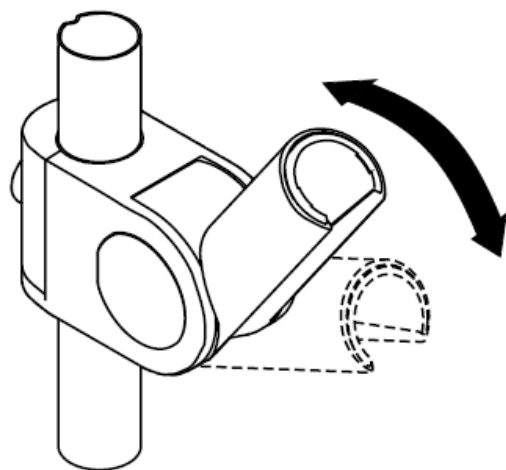

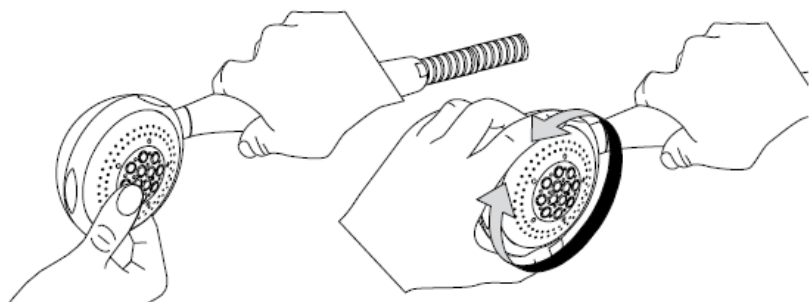

Z Rubit®, ročno čistilno funkcijo, lahko s šob očistimo vodni kamen tako, da šobe enostavno podrgnemo.



Navodila za nego

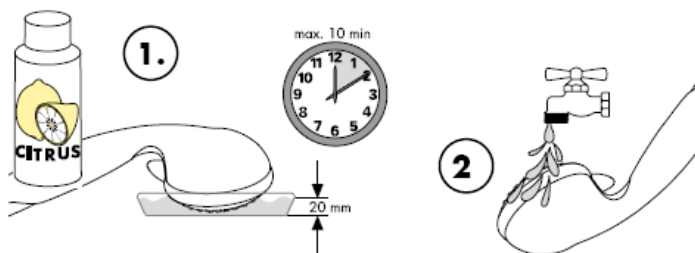

Čiščenje

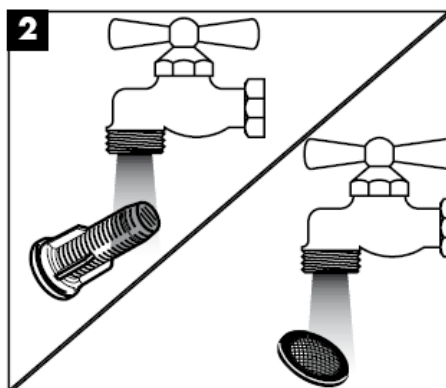
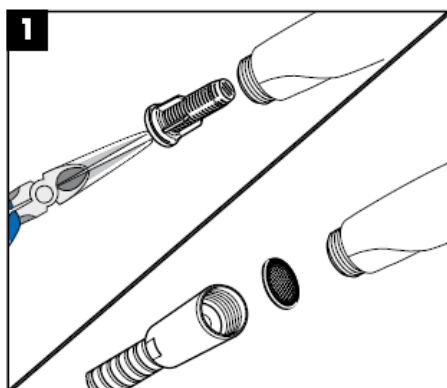
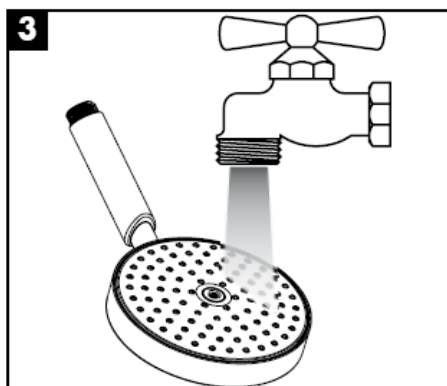
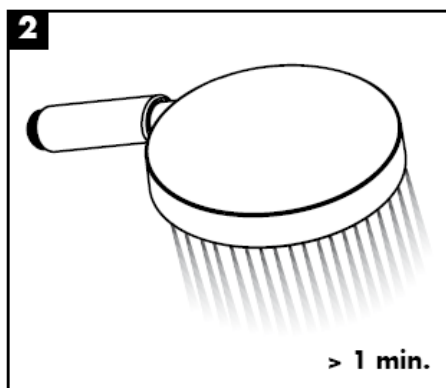
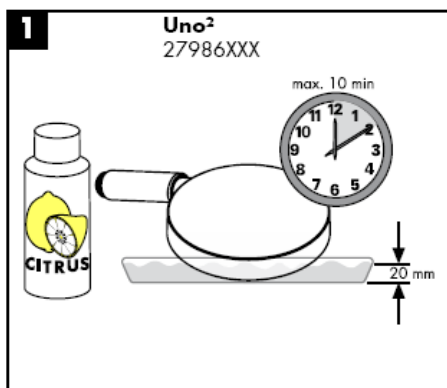

hansgrohe

Paigaldusjuhend

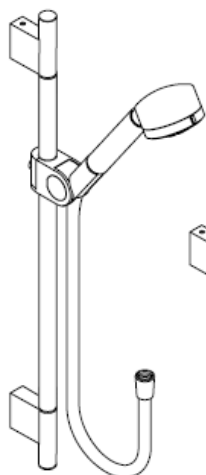

Uno/Arco
27985XXX

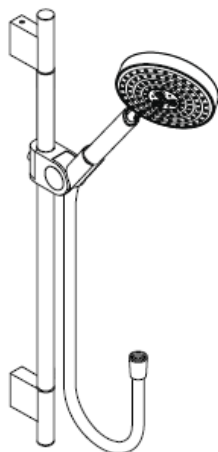

Uno²
27986XXX

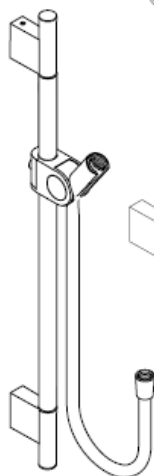

Uno
27989XXX

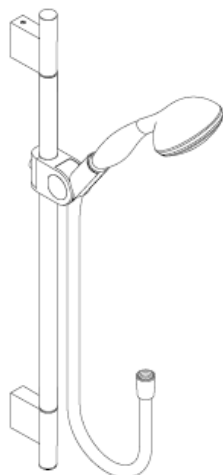

Allegroh
27956000

AXOR®

hansgrohe

Uno/Arco 27985XXX

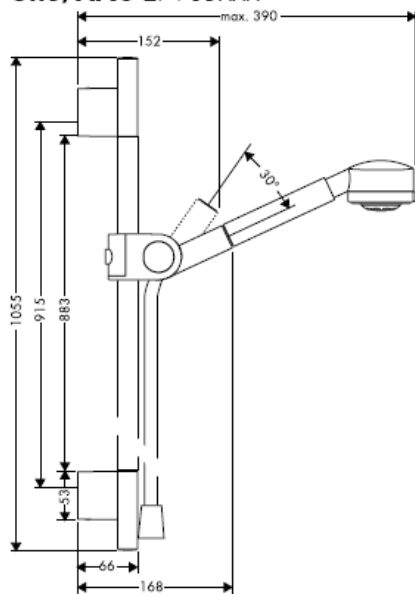

Uno² 27986XXX

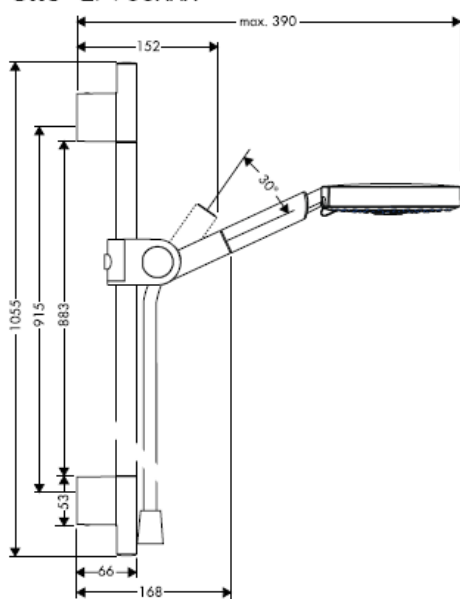

Uno 27989XXX

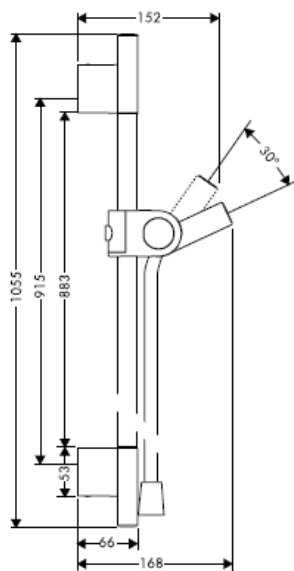

Allegroh 27956000

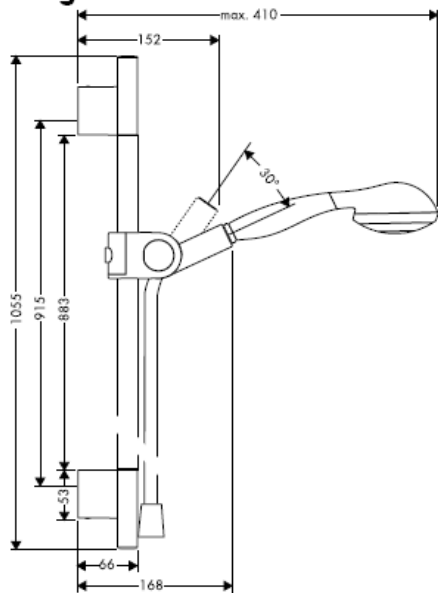



Optimaalne funktsioneerimine on garanteeritud ainult koos Hansgrohe käsiduššide ja Hansgrohe dušivoolikutega. Dušivoolikud sobivad üksnes duši ühendamiseks segistitega. Mingil juhul ei tohi vooliku ja segisti vahele asetada sulgurit.

Tehnilised andmed

Töörõhk	max. 0,6 MPa
Soovitav töörõhk:	0,1 – 0,4 MPa
(1 MPa = 10 baari = 147 PSI)	
Kuuma vee temperatuur:	max. 60° C

Käsidušši sobib kasutada boiler, mille võimsus on alates 21 kW ning minimaalne läbivool 7 l/min.

Uno/Arco 27985XXX

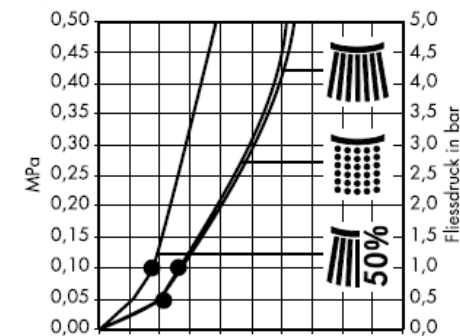
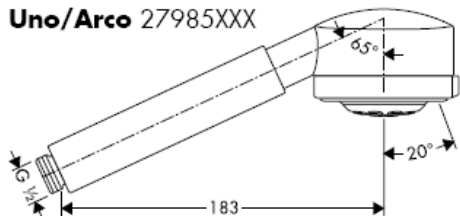

tavajuga



Pehme juga



50%
Massaažpihustus

Allegroh 27956000

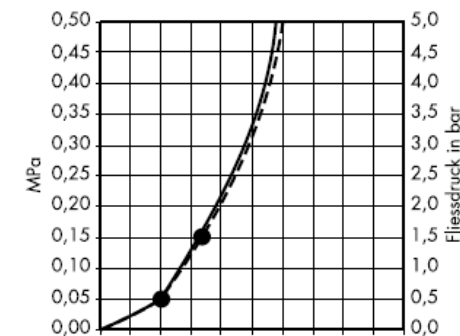
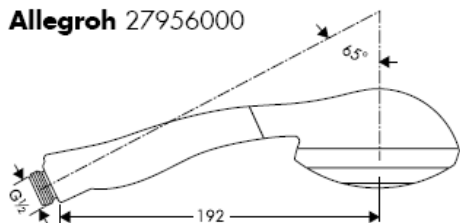

tavajuga



Pehme juga

Uno² 27986XXX

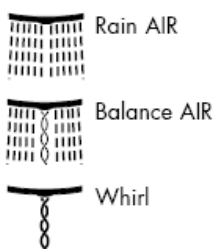
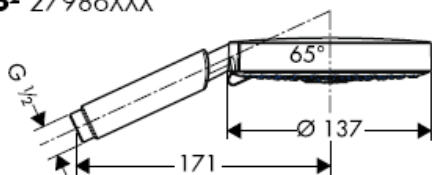

Filtriga (A)

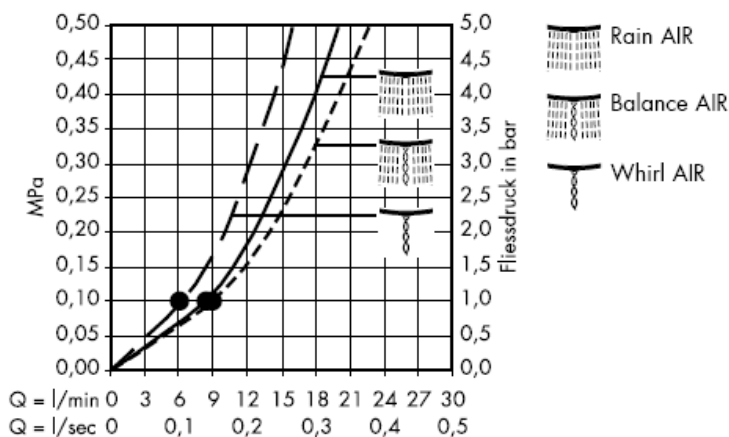

Sõeltihendiga B

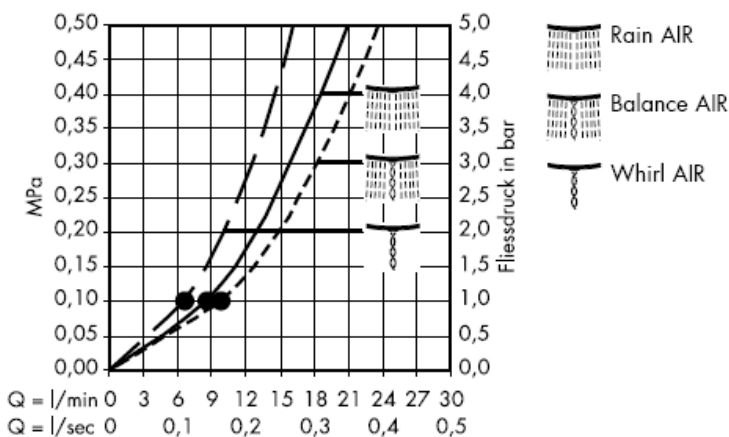

Alates • on funktsioneerimine garanteeritud

Mõõtude puhul arvestage võimalusel plaatide asetusega.

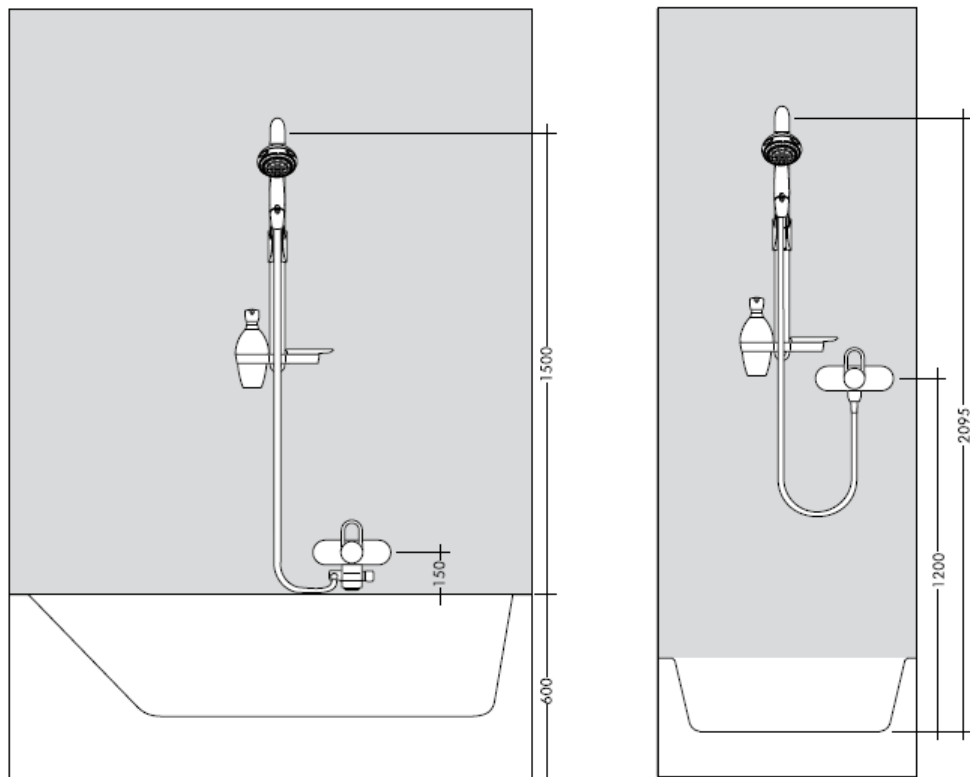

Toote paigaldamisel peab töövõtja tagama, et kogu seinapind, kuhu paigaldusplaat kinnitatakse, on lame (ükski vuuk ega keraamiline plaat ei ulatu esile), ning et seina konstruktsioon on toote paigaldamiseks sobiv ja sellel puuduvad nõrgad kohad.

Kaasasolevad kruvid ja tüüblid sobivad üksnes betoonile. Muude seinakonstruktsioonide puhul tuleb arvesse võtta tüüblitootja esitatud tooteandmeid.

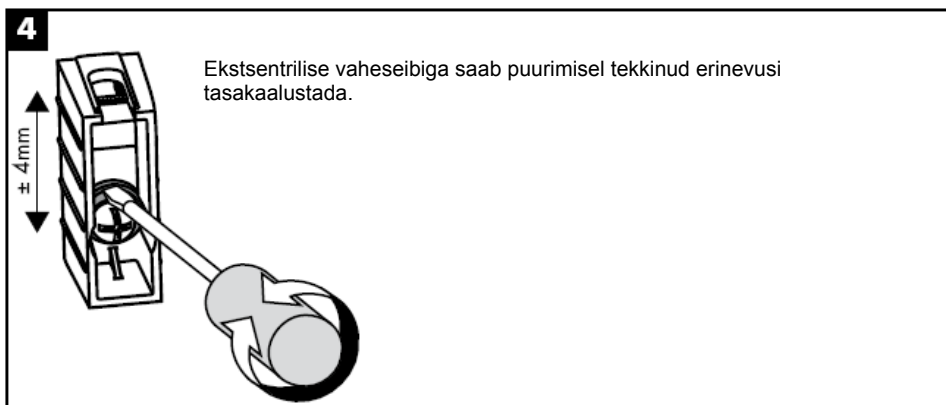
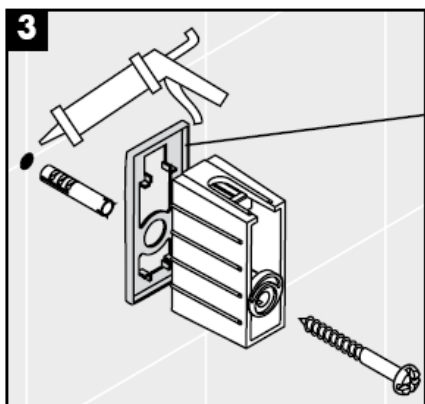
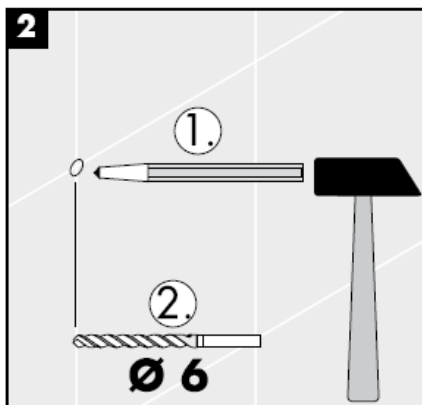
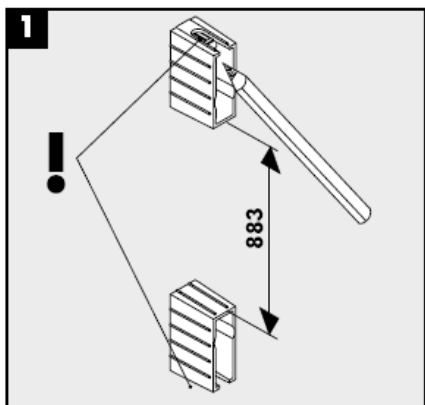

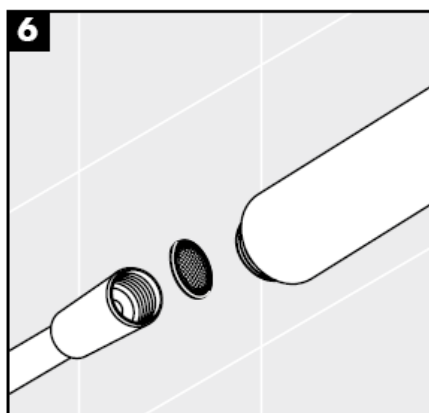
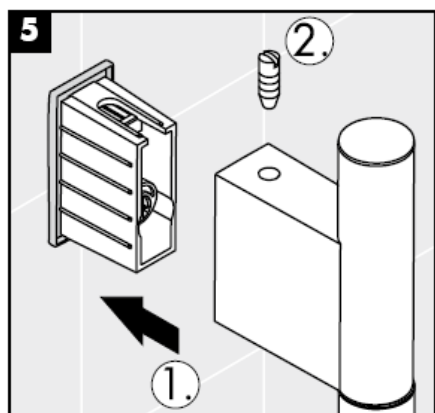

Kaitsmaks dušši torust tuleva mustuse eest, on vaja paigaldada dušiga kaasasolev mustusesõel. Sissetulev mustus võib funktsioneerimist kahjustada ja/või rikkuda dušši detaile. Sellest tulenevate kahjude eest Hansgrohe ei vastuta.

Käsiduši standardse läbivoolu puhul peab veevärgist tuleva mustuse vastu paigaldama kaasasoleva filtri A. Kui soovite suuremat läbivoolu, peab selle asemel kasutama filtrit B. Filtri A või B mittepaigaldamisel käsiduši võib sissetulev mustus funktsioneerimist kahjustada ja/või rikkuda käsiduši detaile. Sellest tulenevate kahjude eest Hansgrohe ei vastuta.

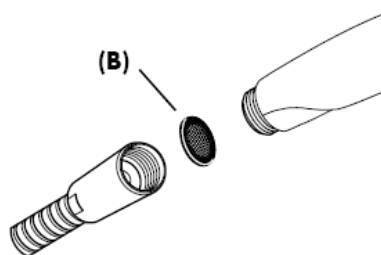
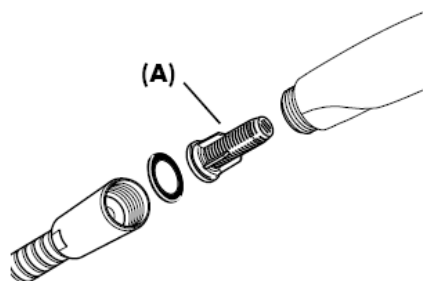

Reguleerimine

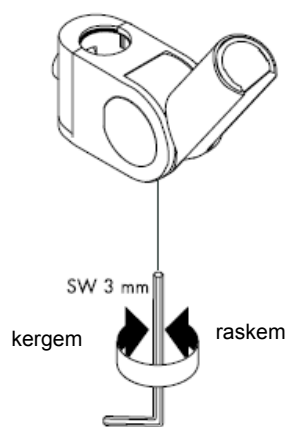
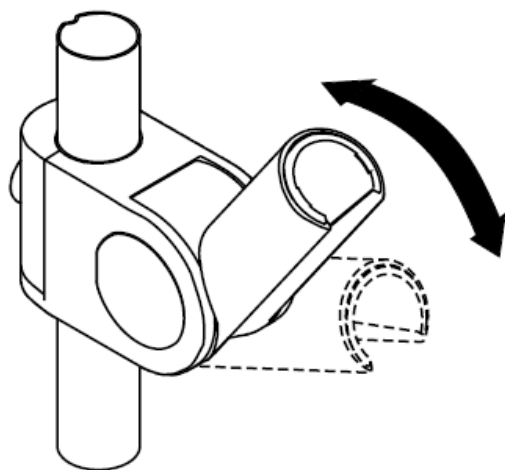
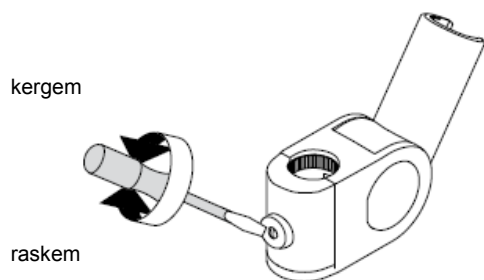
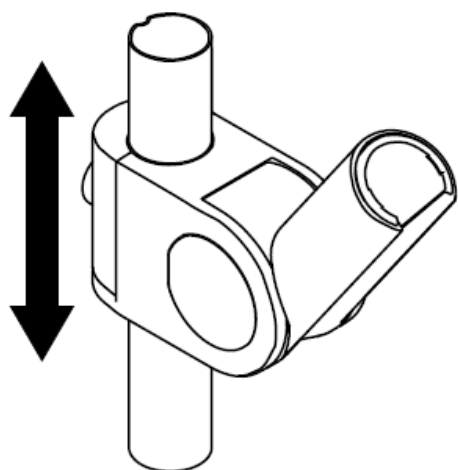

Puhastamine

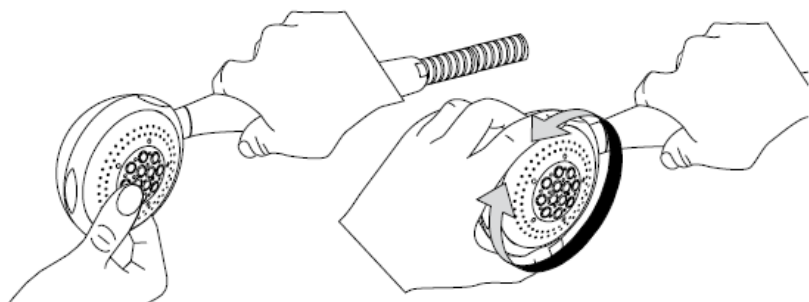

Käsitsi puhastamise funktsiooni Rubit® puhul on vajalik vaid kerge ülehõõrumine, eemaldamaks dušikanalistest katlakivi.

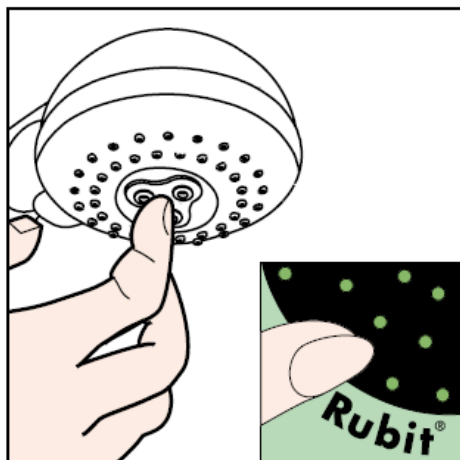

Hooldusjuhend

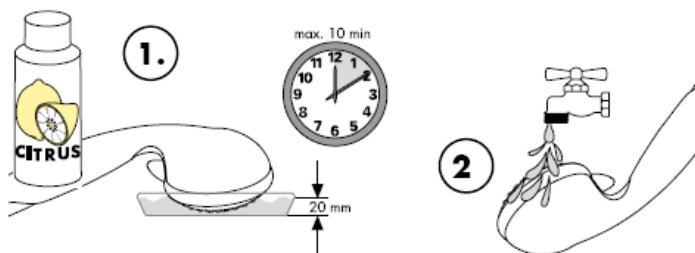

Puhastamine

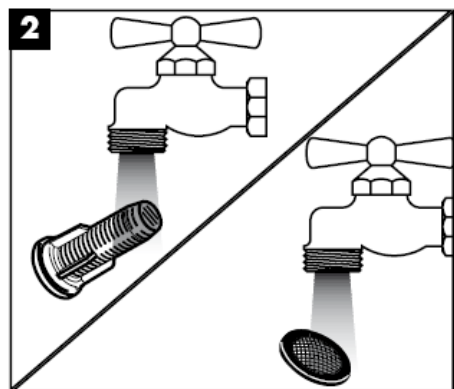
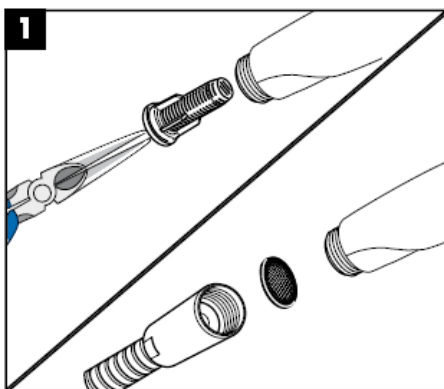
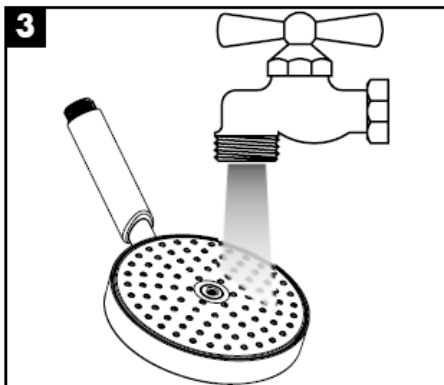
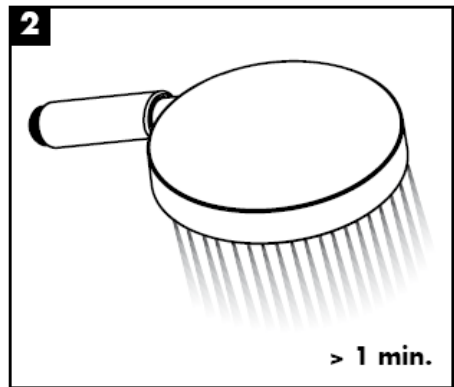
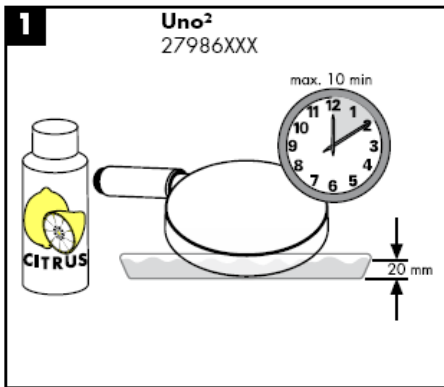

hansgrohe

Montāžas instrukcija

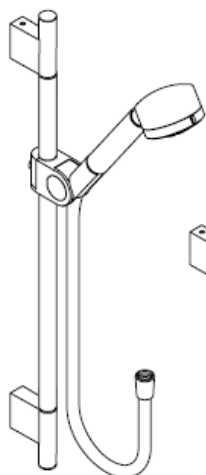

Uno/Arco
27985XXX

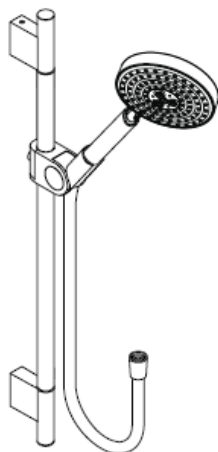

Uno²
27986XXX

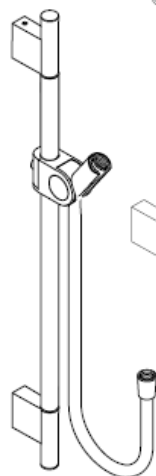

Uno
27989XXX

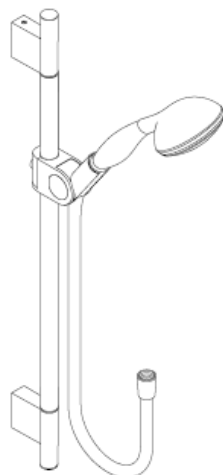

Allegroh
27956000

AXOR[®]

hansgrohe

Uno/Arco 27985XXX

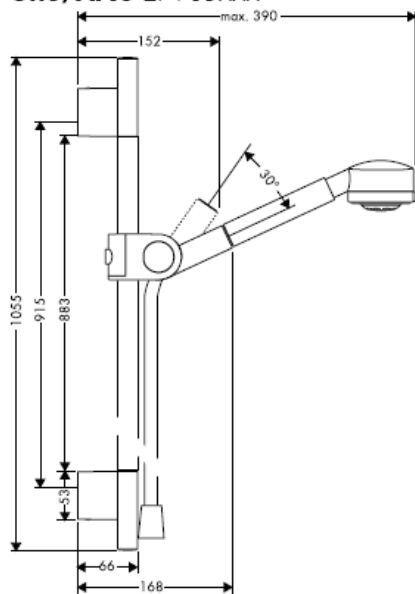

Uno² 27986XXX

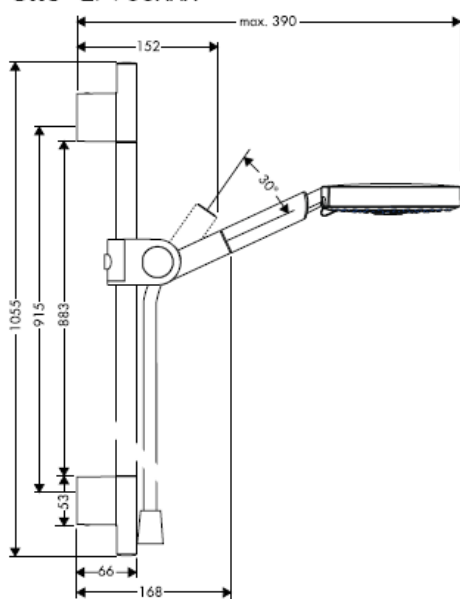

Uno 27989XXX

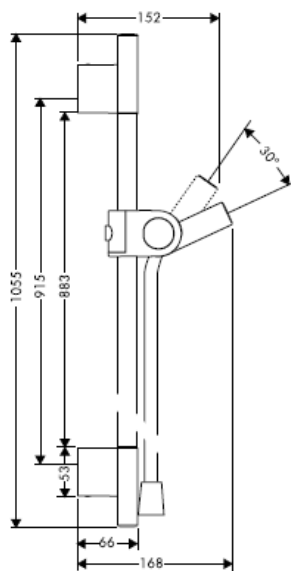

Allegroh 27956000

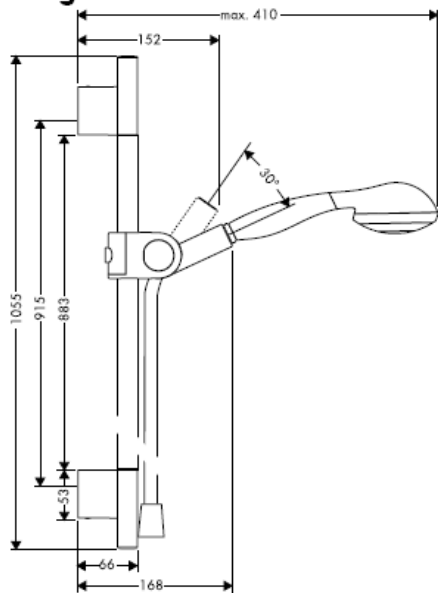



Optimāla funkcija tiek garantēta tikai kombinācijā ar Hansgrohe rokas dušām un Hansgrohe dušas šļūtenēm. Dušas šļūtenes ir piemērotas tikai dušas pieslēgšanai pie jaucējkrāna. Nepieļaujama ir noslēgarmatūras pievienošana aiz šļūtenes plūsmas virzienā!

Tehniskie dati

Darba spiediens:	max. 0,6 MPa
Ieteicamais darba spiediens: (1 MPa = 10 bar = 147 PSI)	0,1 – 0,4 MPa
Karstā ūdens temperatūra:	max. 60° C

Rokas duša ir piemērota caurteces sildītājam, kura jauda ir 21 kW un minimālā caurtece 7 l/min.

Uno/Arco 27985XXX

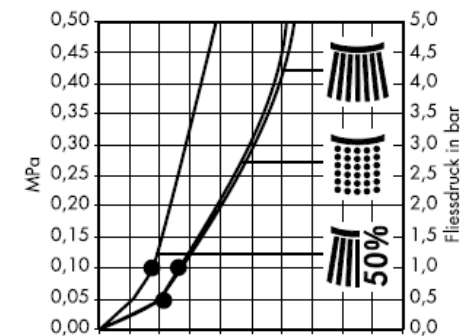
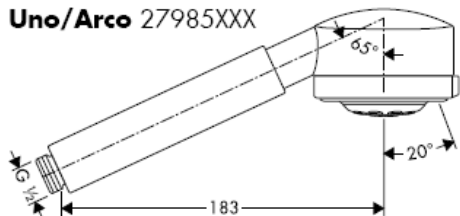

Standarta strūkļa



Maiga strūkļa



Eco-strūkļa

Allegroh 27956000

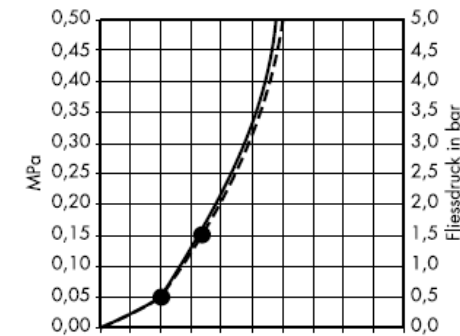
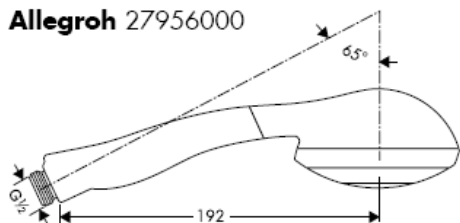

Standarta strūkļa



Maiga strūkļa

Uno² 27986XXX

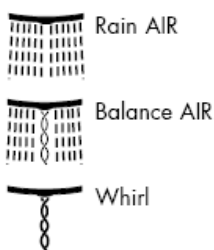
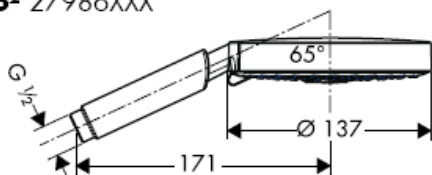

Ar filtra ieliktni (A)

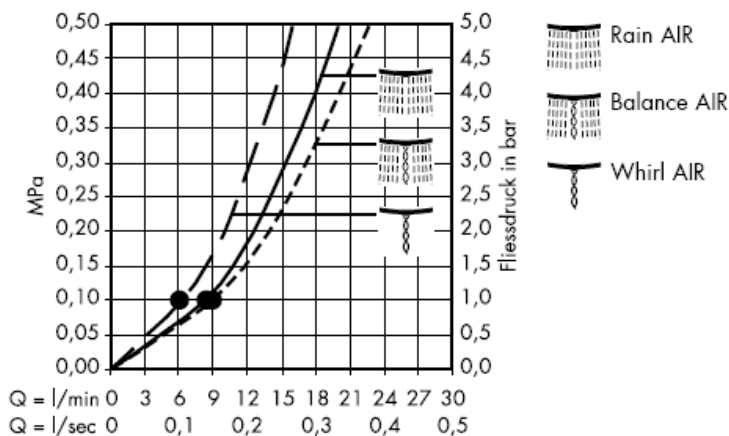

Ar filtra blīvējumu (B)

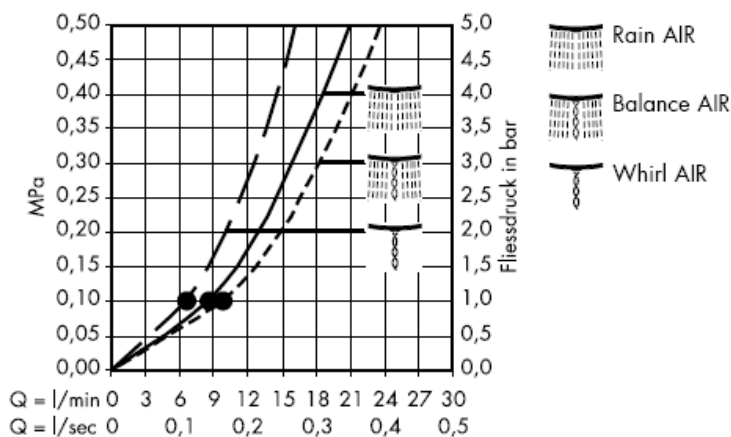

No • funkcija nodrošināta

Izmērus pēc iespējas pielādzināt flīžu rakstam.

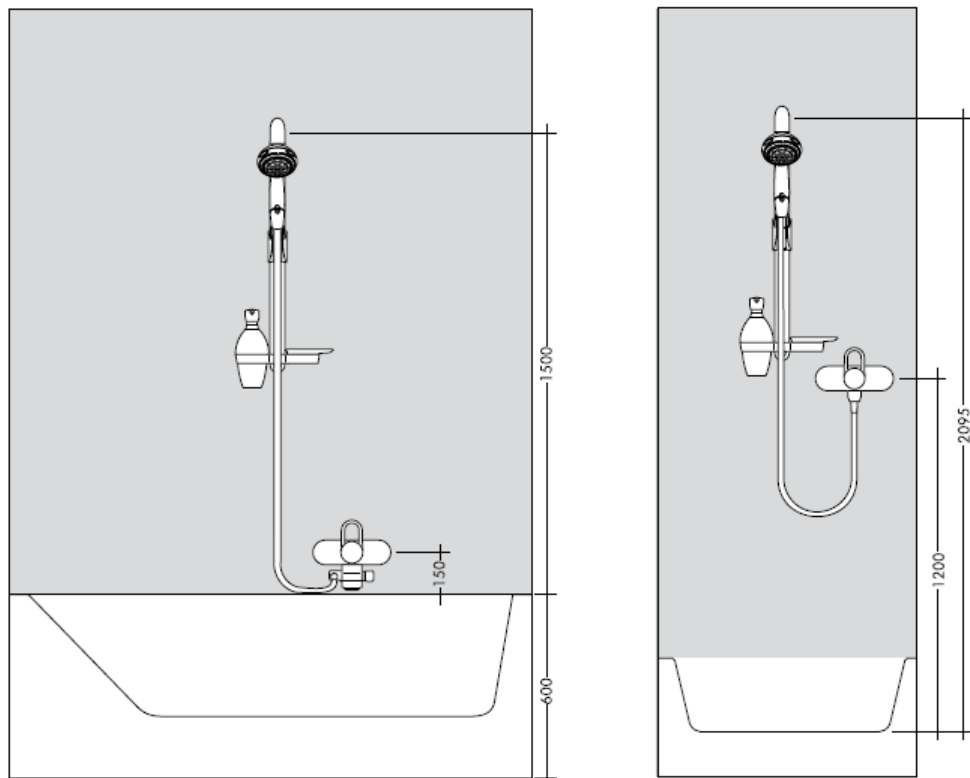

Ja izstrādājuma montāžu veic kvalificēti speciālisti, jāseko, lai nostiprināšanas virsma visā nostiprināšanas zonā būtu gluda (šuves un flīzes nav izvirzītas uz āru), lai sienas konstrukcija būtu piemērota izstrādājuma montāžai un būtu pietiekami izturīga.

Komplektā esošās skrūves un dībeļi ir paredzēti tikai šī izstrādājuma nostiprināšanai.

Ja sienas konstrukcija ir citāda, jāievēro dībeļu ražotāja norādījumi.

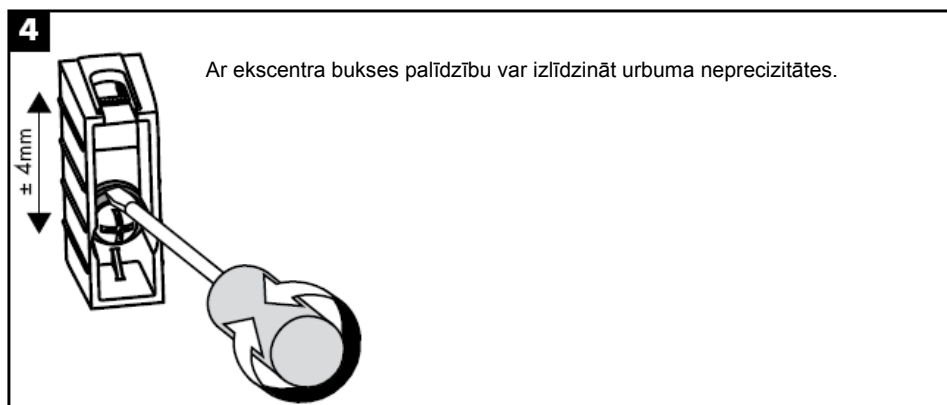
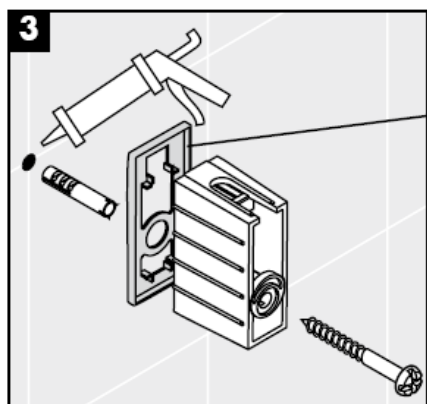
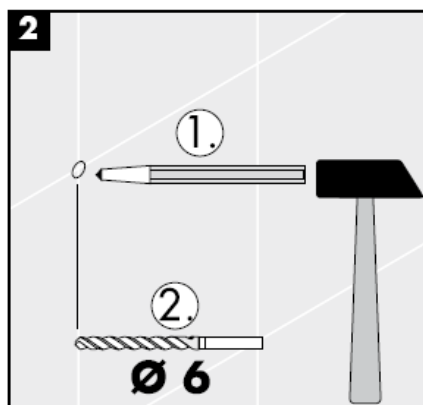
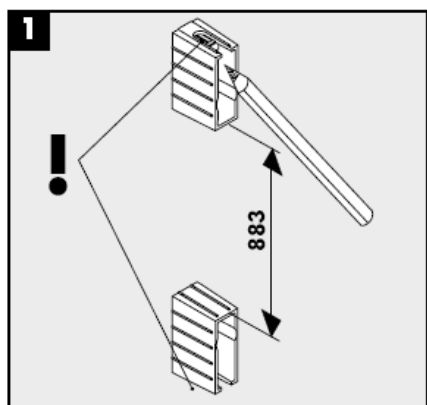

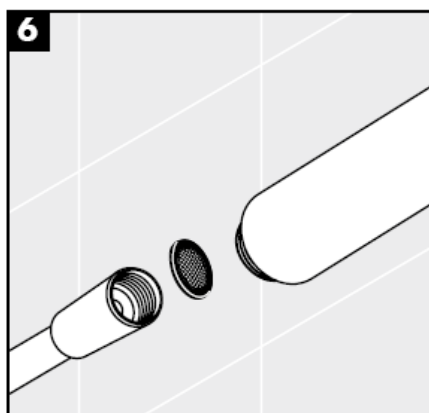
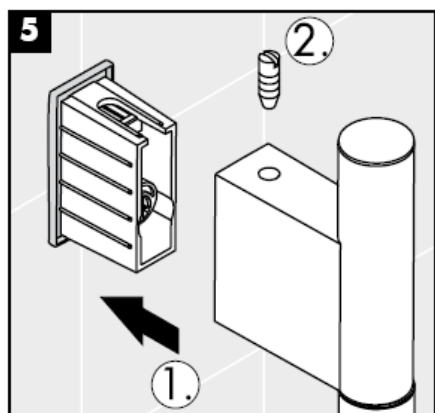

Jāiemonē dušas komplektā esošais filtrs, lai novērstu netīrumu ieplūšanu no ūdens vada. Ieskalotie netīrumi var traucēt dušas funkciju un / vai arī izraisīt rokas dušas daļu bojājumus, par kuriem Hansgrohe nenes atbildību.

Lai nodrošinātu rokas dušas normālu ūdens caurplūdi un izvairītos no netīrumu ieskalšanas no ūdensvada, jāiemonē komplektā esošais filtrs (A). Ja ir nepieciešamība pēc lielākas ūdens caurplūdes, tad filtra (A) vietā jāizmanto sietiņš (B). Ieskalotie netīrumi var traucēt dušas funkciju un / vai arī izraisīt rokas dušas funkciju bojājumus, par kuriem Hansgrohe nenes atbildību.

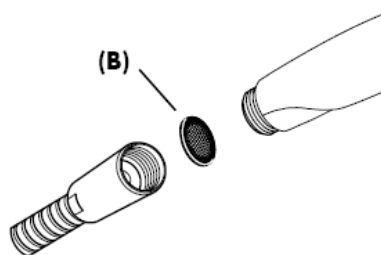
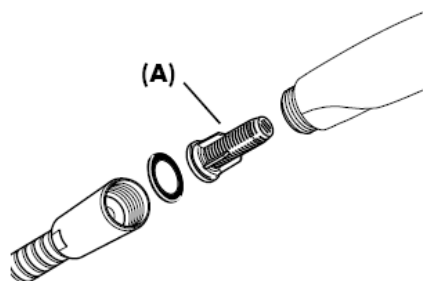

Ieregulēšana

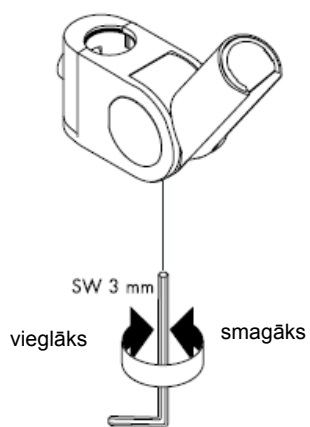
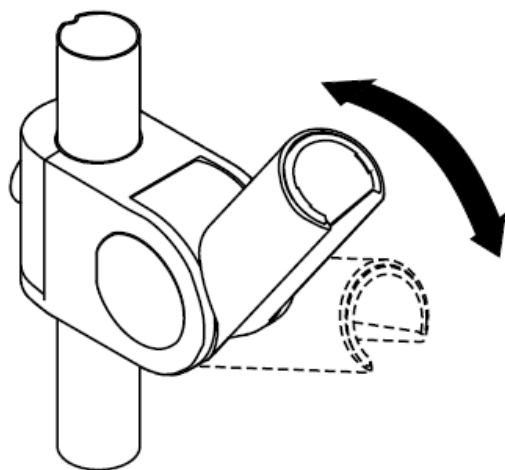
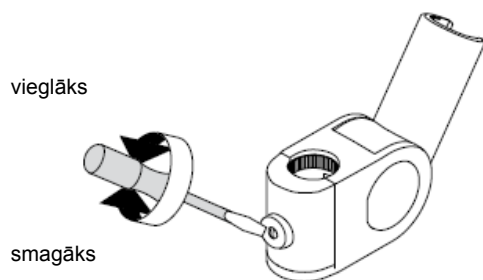
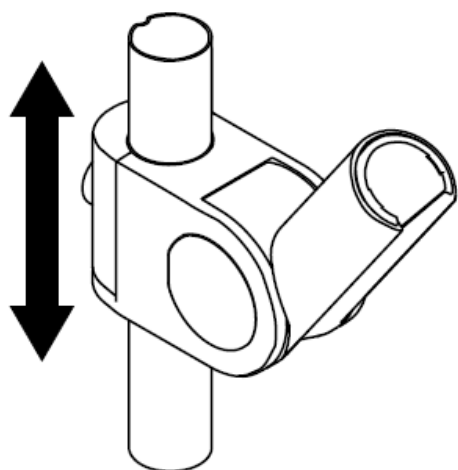

Tīrīšana

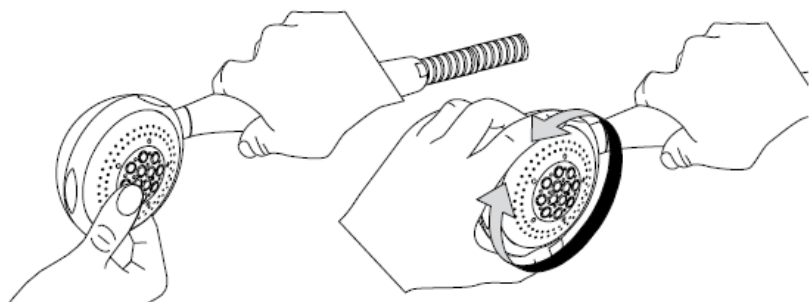

Rubit® attīrīšanas funkcija - strūklas kanāliņi vienkāršas manuālas berzes rezultātā tiek attīrīti no kalcja.

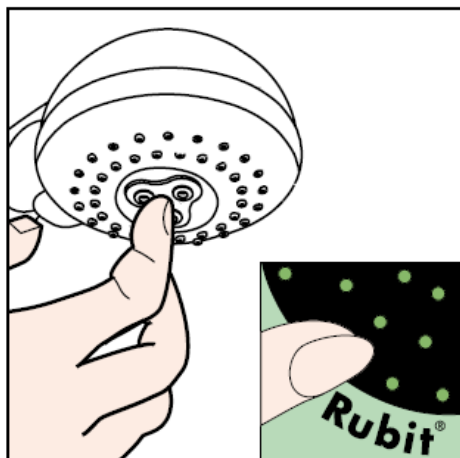

Kopšanas instrukcija

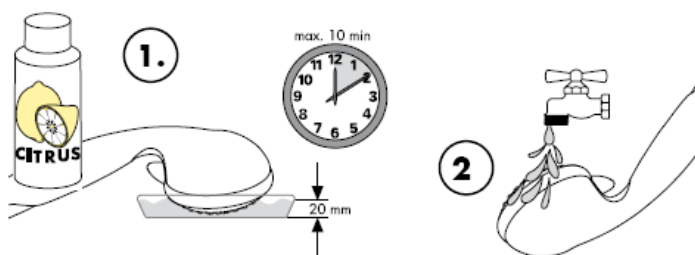

Tīrīšana

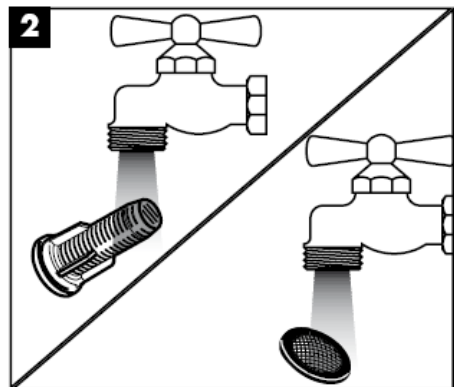
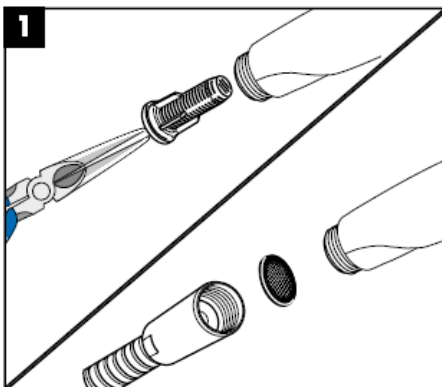
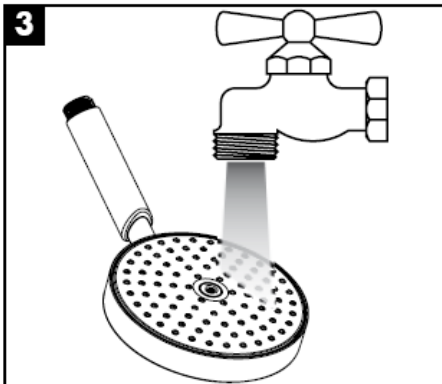
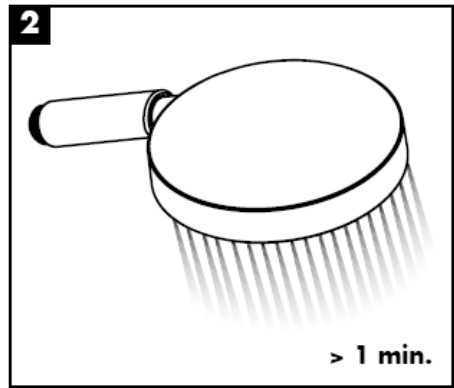
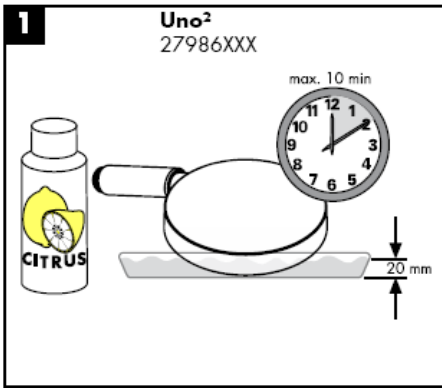

hansgrohe

Uputstvo za montažu

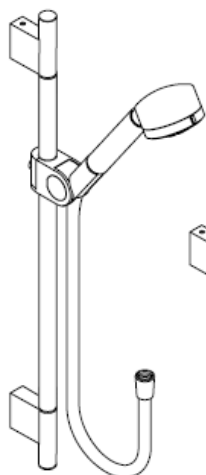

Uno/Arco
27985XXX

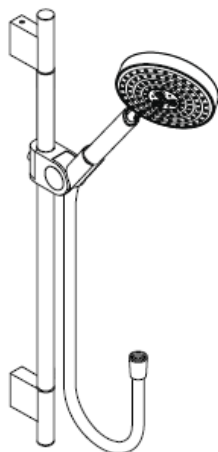

Uno²
27986XXX

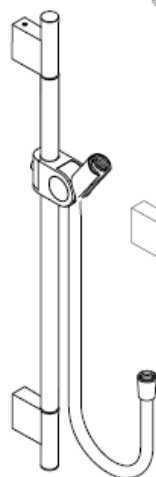

Uno
27989XXX

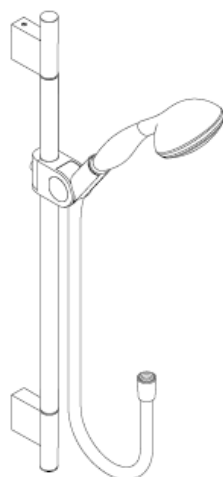

Allegroh
27956000

AXOR®

hansgrohe

Uno/Arco 27985XXX

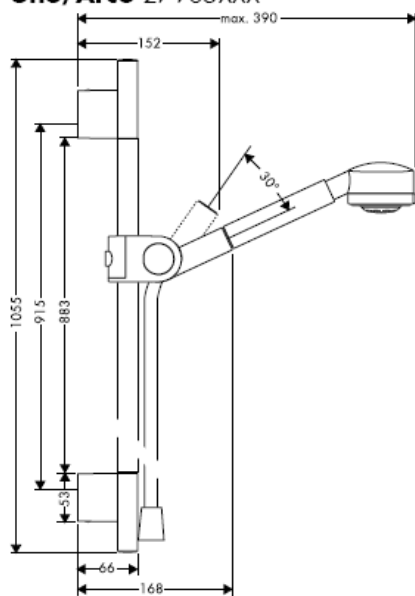

Uno² 27986XXX

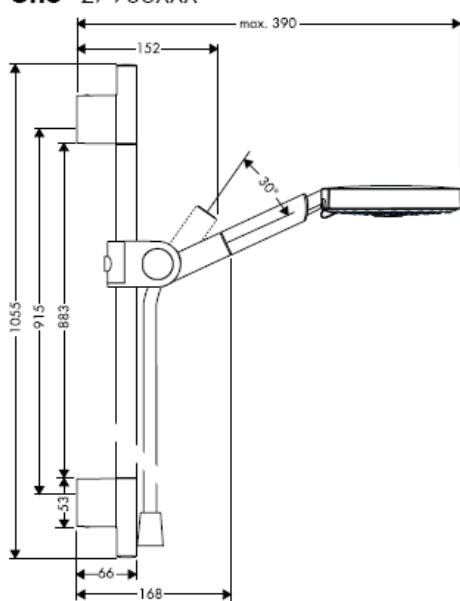

Uno 27989XXX

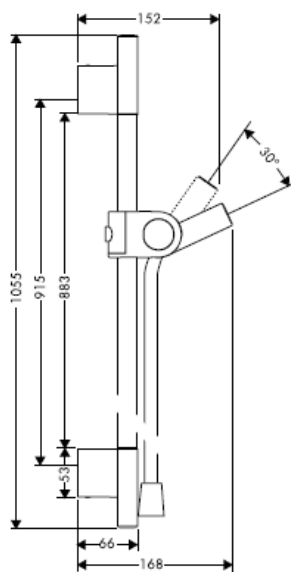

Allegroh 27956000

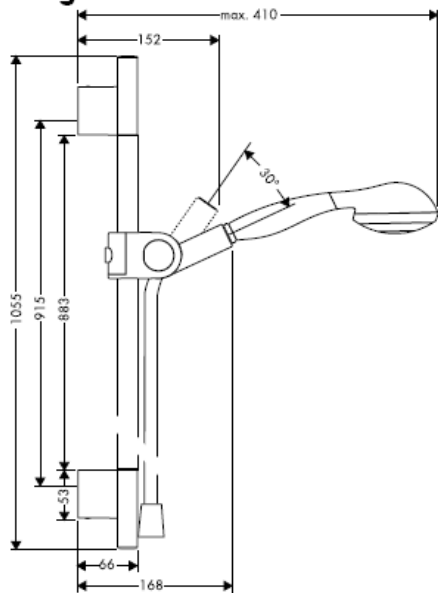



Optimalno funkcionisanje je garantovano jedino u kombinaciji sa Hansgrohe ručnim tuševima i Hansgrohe crevom za tuš. Creva tuša prikladna su jedino za spajanje tuševa na armature. Nije dopušteno blokiranje creva u smeru protoka vode!

Tehnički podaci

Radni pritisak:	max. 0,6 MPa
Preporučeni radni pritisak: (1 MPa = 10 bar = 147 PSI)	0,1 – 0,4 MPa
Temperatura vruće vode:	max. 60° C

Ručni tuš možete koristiti uz protočni bojler snage od 21 kW ili veće, te uz minimalni protok od 7 l/min.

Uno/Arco 27985XXX

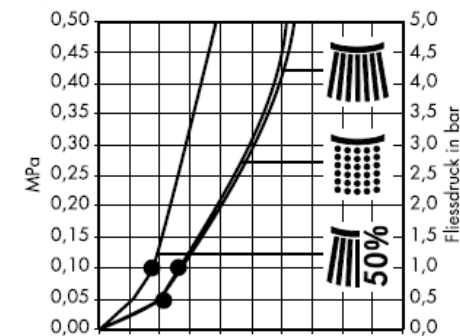
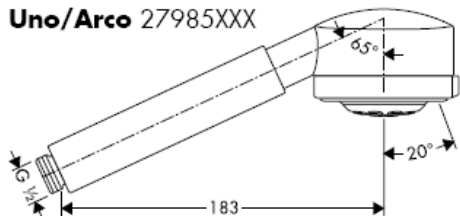

Normalni mlaz



Nežni mlaz



Eco-mlaz

Allegroh 27956000

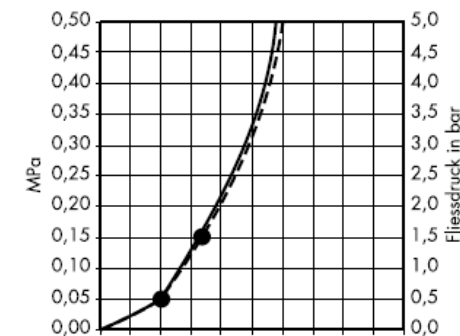
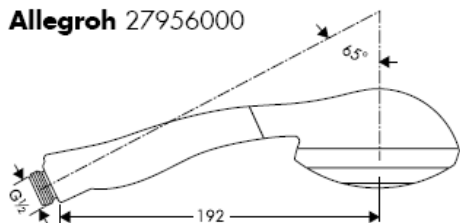

Normalni mlaz



Nežni mlaz

Uno² 27986XXX

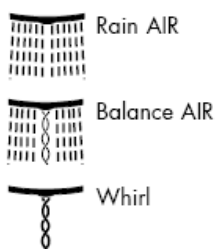
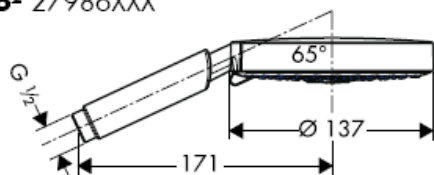

S filterom (A)

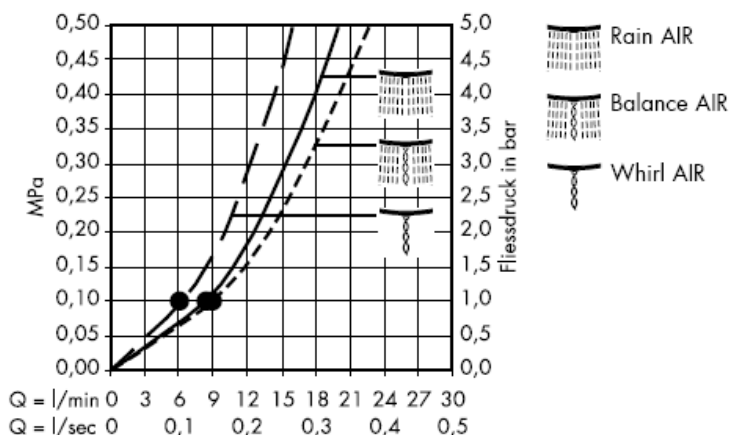

S mrežastom zaptivkom (B)

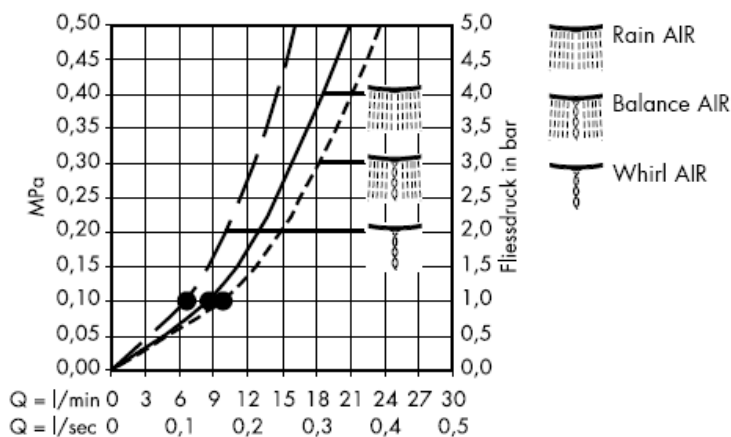

Od • je funkcija zagarantovana.

Prilagodite meru što je više moguće rasteru pločica.

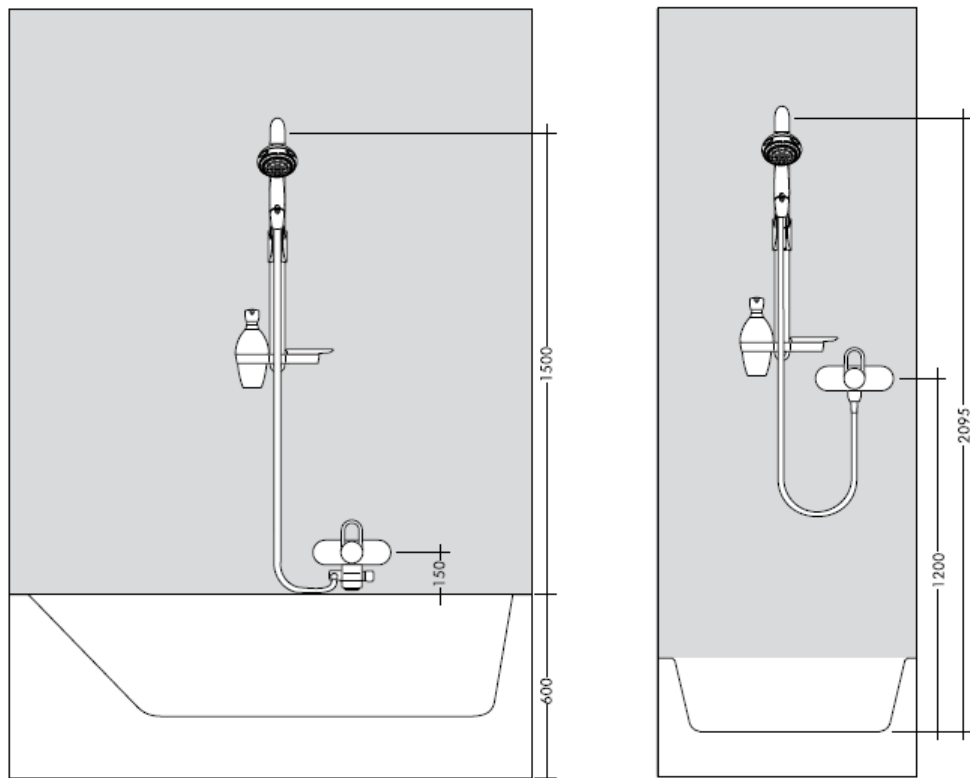

Kada proizvod montira kvalifikovano stručno osoblje treba paziti da čitava površina na koju se učvršćuje bude ravna (bez istaknutih fuga ili krivljenja pločica), da je zidna konstrukcija primerena montaži proizvoda, i posebno da nema slabih mesta.

Priloženi zavrtnji i tiplovi prikladni su samo za beton. Kod drugih zidnih nadgradnji treba obratiti pažnju na navode proizvođača tiplova.

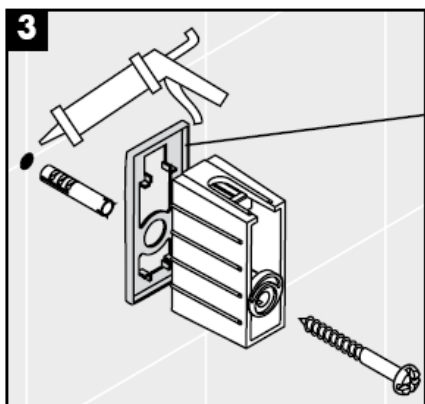
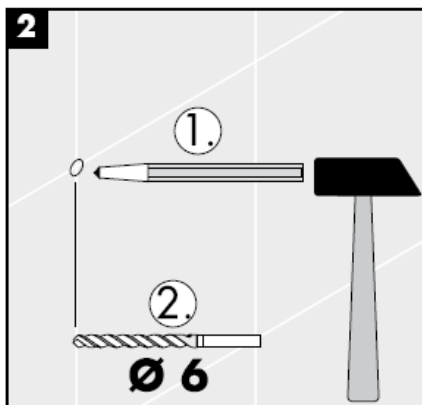
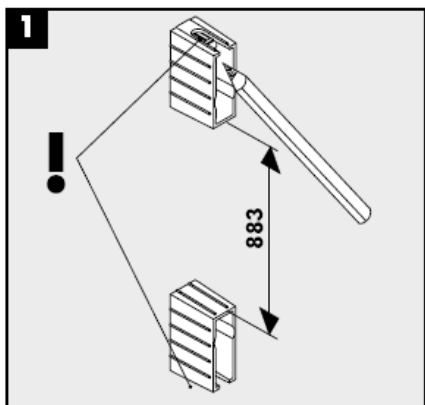

Ukrasni prsten samo kod varijante hrom/zlato!

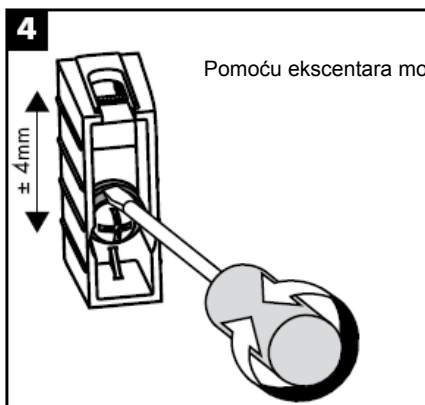

Pomoću ekscentara mogu se podesiti tolerancije provrta.

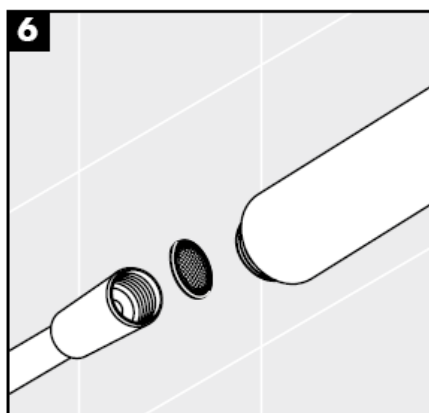
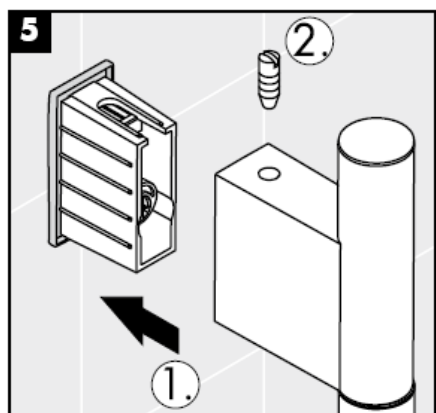

Obavezno ugradite mrežicu (A) upakovanu s tušem, čime sprečavate ulazak prljavštine iz vodovoda. Prljavština može dovesti do delimičnog ili potpunog oštećenja delova tuša. Za eventualna oštećenja uzrokovana prljavštinom proizvođač Hansgrohe nije odgovoran.

Isporučeni umetak filtra (A) se mora ugraditi kako bi se regulisao protok vode i smanjio prolazak prljavštine iz vodovoda. Ako želite jači protok vode, umesto filtra (A) ugradite mrežastu zaptivku (B). Za eventualna oštećenja ili lošije funkcionisanje ručnog tuša uzrokovano prljavštinom, proizvođač Hansgrohe nije odgovoran.

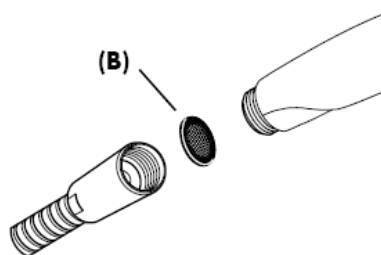
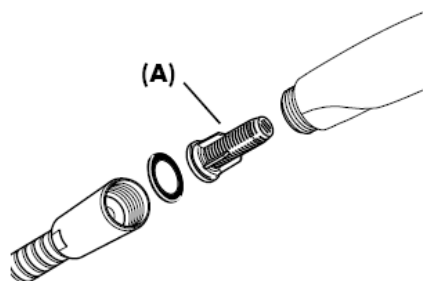

Podešavanje

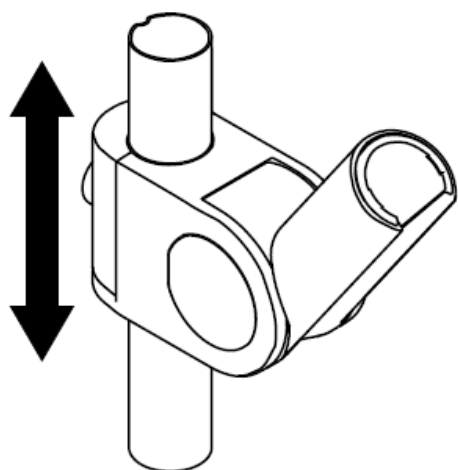

lakši

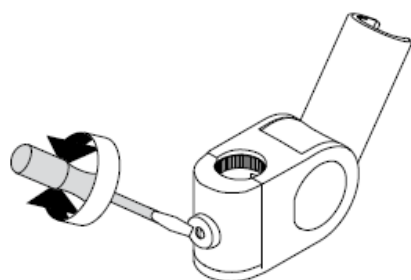

teže

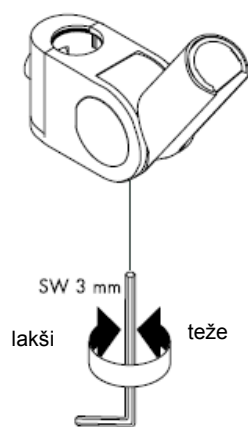
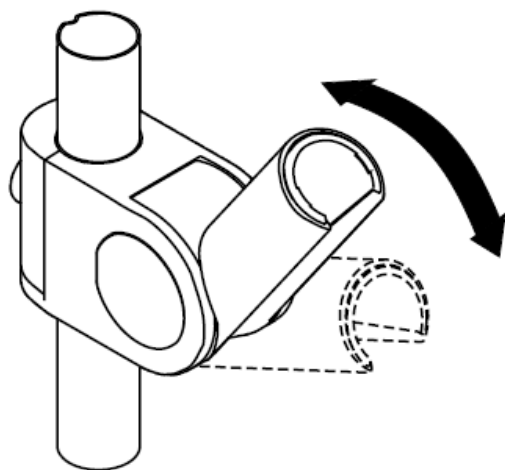

Čišćenje

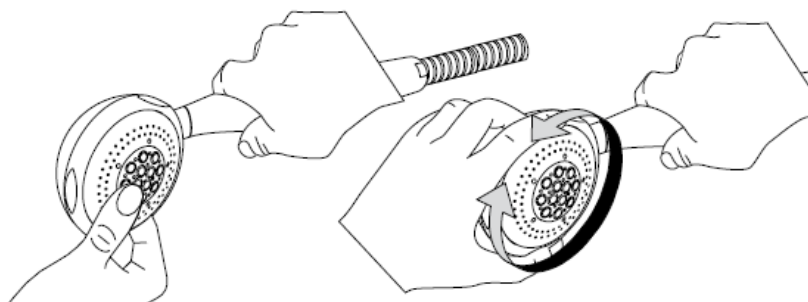

Rubit® - ručni sistem za čišćenje omogućuje odstranjivanje kamenca s rupica uobličavača mlaza, jednostavnim trljanjem.



Uputstvo za održavanje

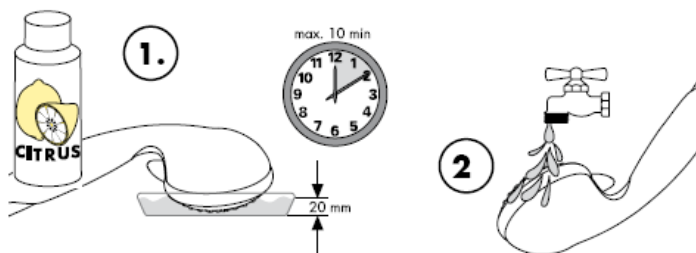

Čišćenje

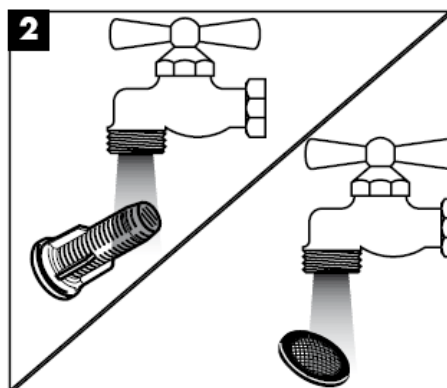
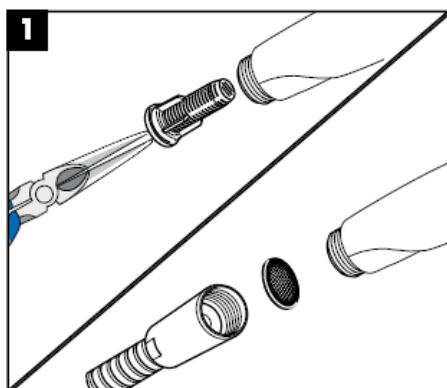
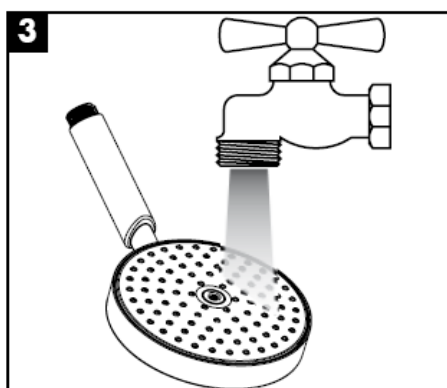
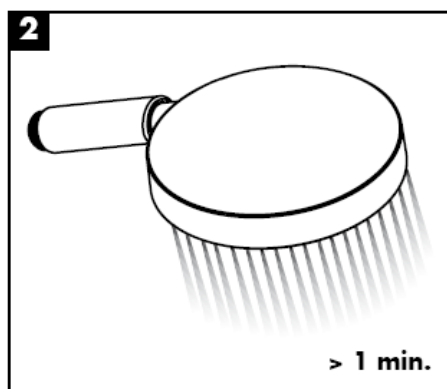
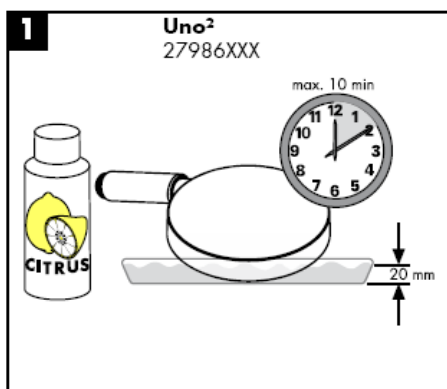

hansgrohe

Montasjeveiledning

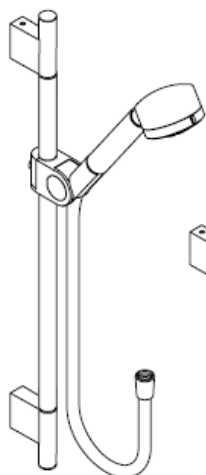

Uno/Arco
27985XXX

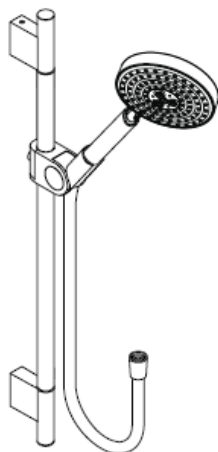

Uno²
27986XXX

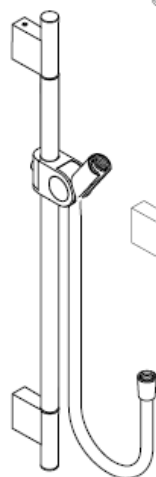

Uno
27989XXX

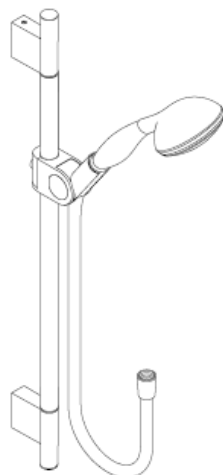

Allegroh
27956000

AXOR®

hansgrohe

Uno/Arco 27985XXX

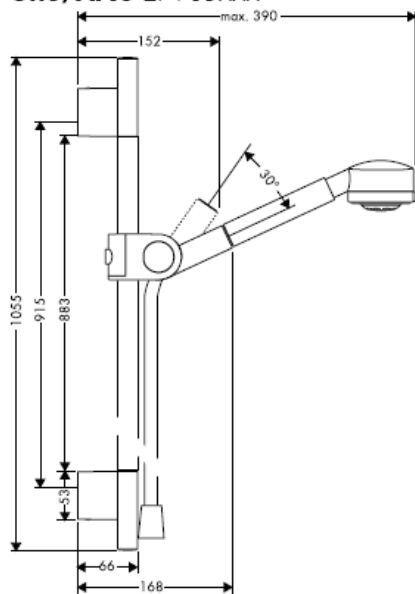

Uno² 27986XXX

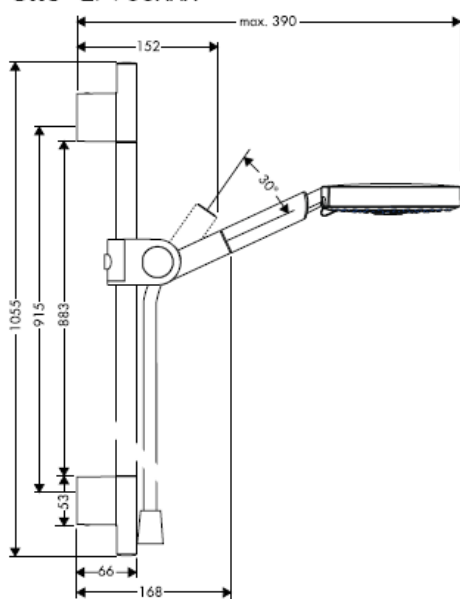

Uno 27989XXX

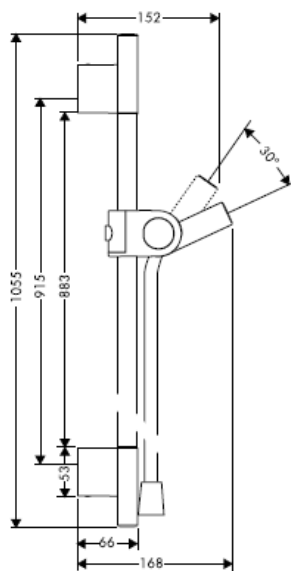

Allegroh 27956000

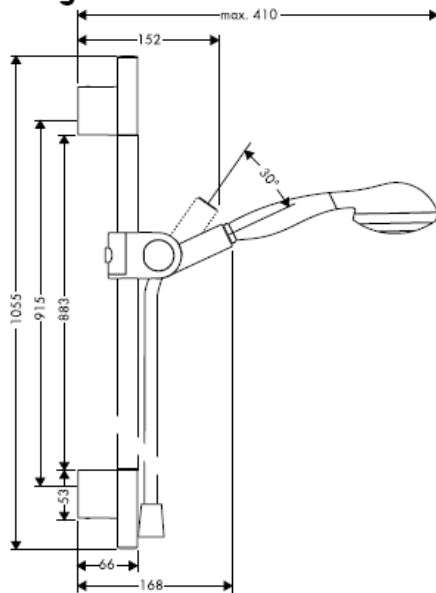



Optimal funksjon garanteres kun i forbindelse med Hansgrohe hånddusj og Hansgrohe dusjslanger. Dusj slanger er kun egnet for tilkobling av dusj til armaturer. Det er ikke tillatt med en avsperring etter slangen i gjennomstrømningsretning!

Tekniske data

Driftstrykk	max. 0,6 MPa
Anbefalt driftstrykk: (1 Mpa = 10 bar = 147 PSI)	0,1 – 0,4 MPa
Varmtvannstemperatur	max. 60° C

Hånddusjen egner seg for bruk sammen med en gjennomstrømningsovner fra og med en ytelse på 21 kW og en minimum gjennomstrømning på 7l/min.

Uno/Arco 27985XXX

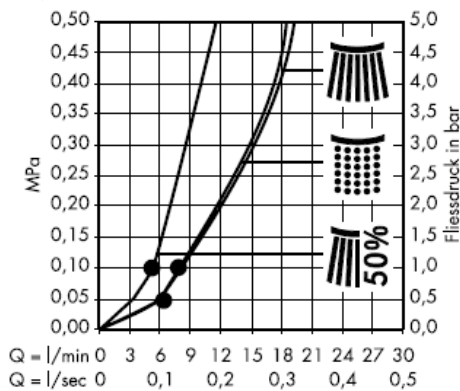
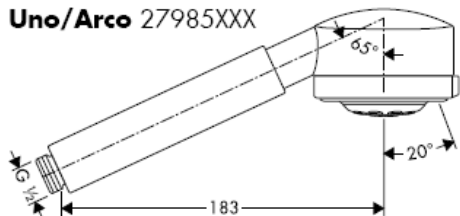

Normalstråle



Softstråle



Ecostråle

Allegroh 27956000

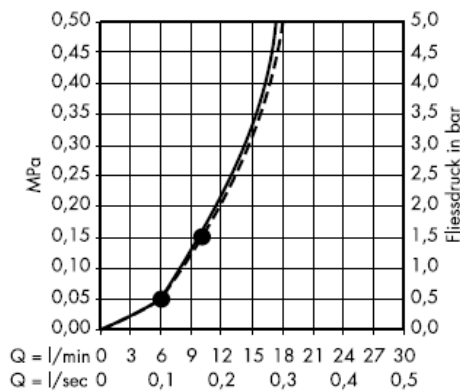
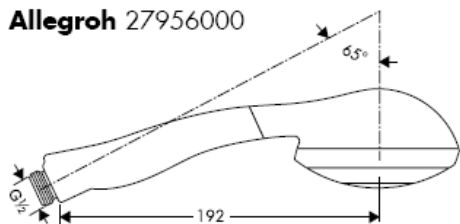

Normalstråle



Softstråle

Uno² 27986XXX

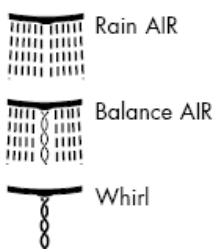
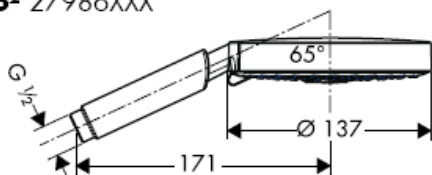

Med filterinnsats (A)

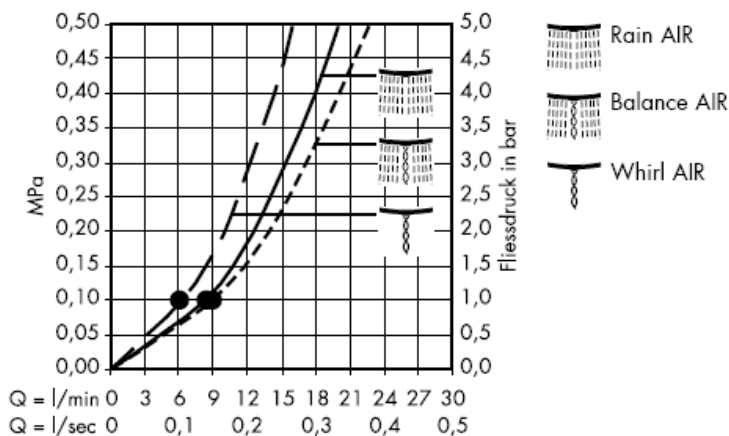

Med silpakning (B)

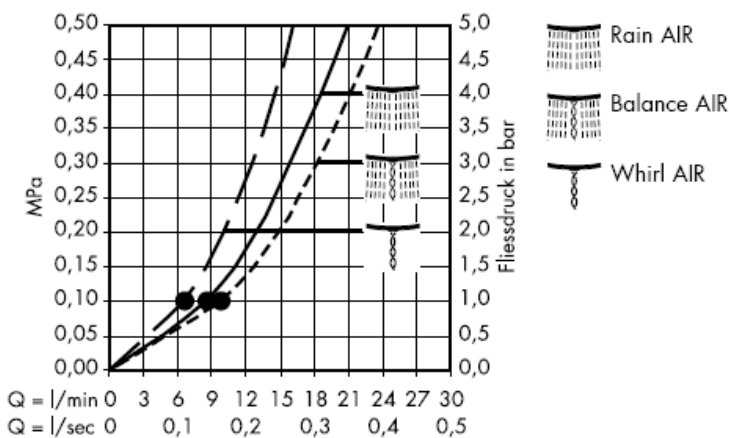

F.o.m. • er funksjonen garantert

Hvis det er mulig tilpasses mål til fliseraster.

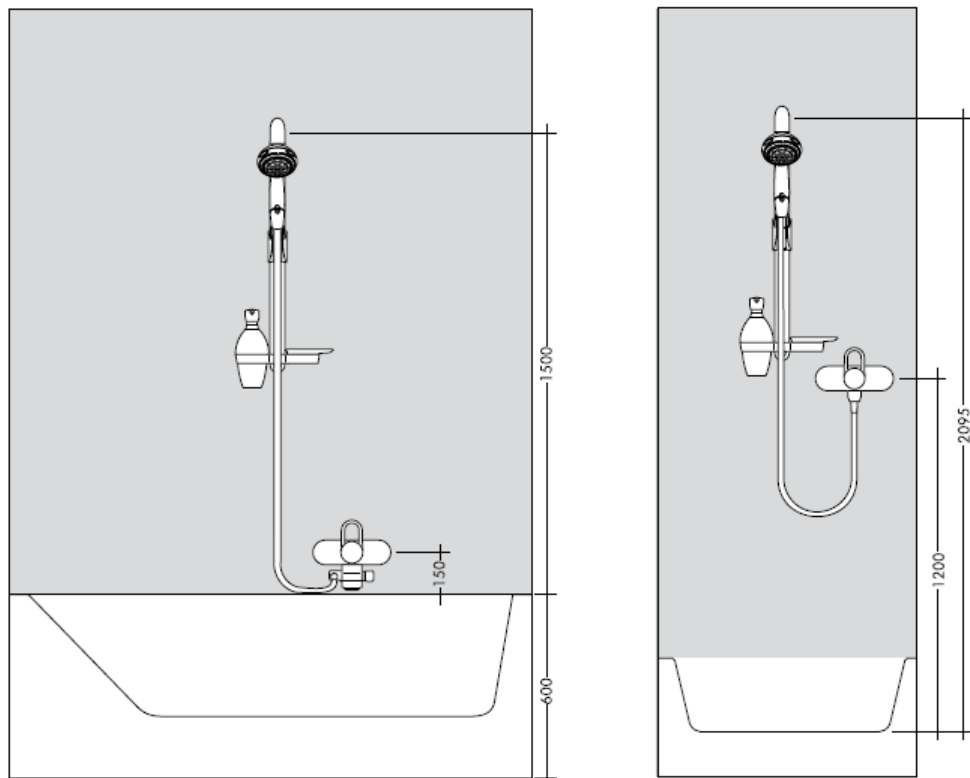

Når kvalifisert fagfolk monterer produktet, skal man påse at hele området der produktet monteres er plant (ingen fremstående fuger eller flisekanter), at oppbygging av vegg er egnet for montasje av produktet og at vegg ikke viser noen svakpunkter. Medleverte skruer og plugger egner seg kun for betong. Ved en annen veggoppbygging skal man ta hensyn til pluggproduzentens henvisninger.

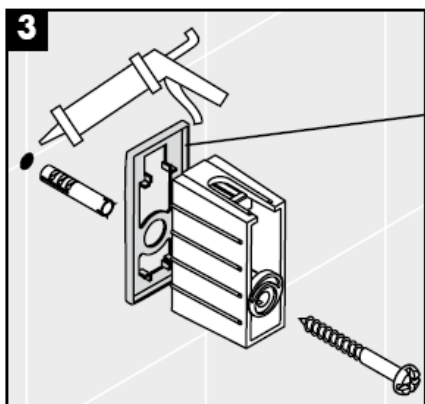
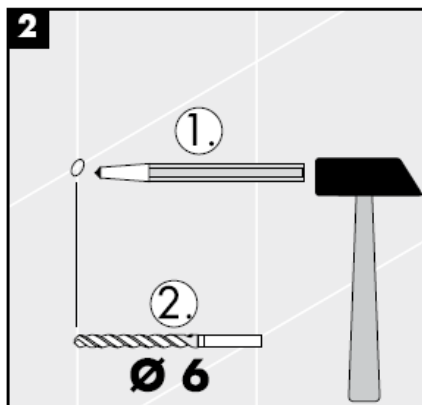
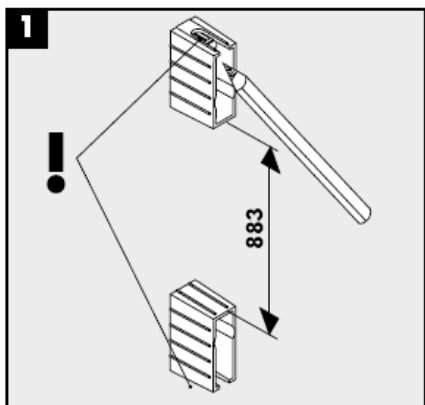

Dekoring kun ved krom/gull variant

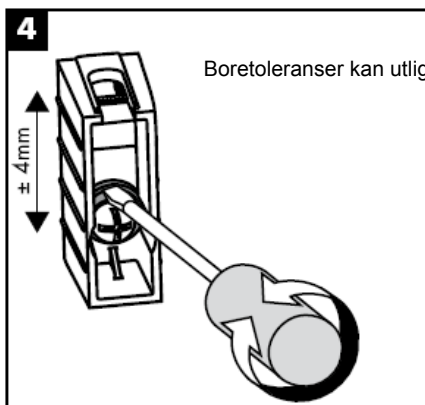

Boretoleranser kan utlignes ved hjelp av eksenterbøssing.

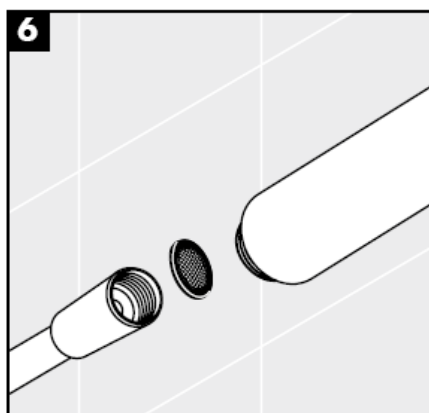
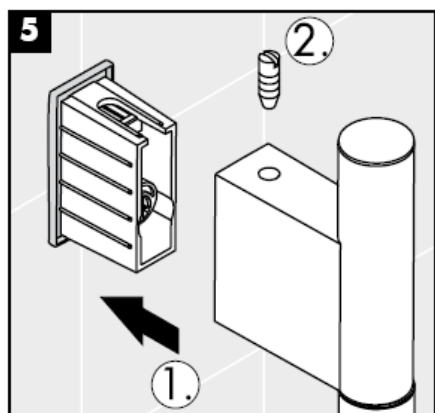

Silpakningen som er levert med dusjen skal bygges inn for å forhindre at smuss spyles inn fra ledningsnett. Innspylt smuss kan påvirke funksjonen negativt og/eller kan medføre skader på hånddusjens funksjonsdeler. Hansgrohe påtar seg inget ansvar for skader som resulteres av dette.

Det medleverte filter-elementet skal bygges inn, for å garantere hånddusjens standard-gjennomstrømning og for å forhindre at smuss spyles inn fra ledningsnett. Ønsker man en større vanngjennomstrømning skal det monteres en silpakning (B) isteden for filterelementet (A). Innspyling av smuss kan påvirke funksjonen negativt og/eller medføre skader på hånddusjens funksjonsdeler. Hansgrohe påtar seg inget ansvar for skader som resulteres av dette.

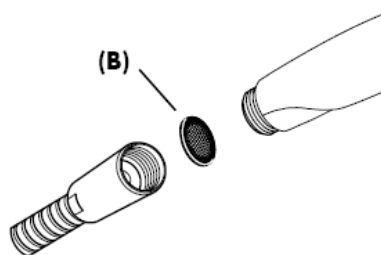
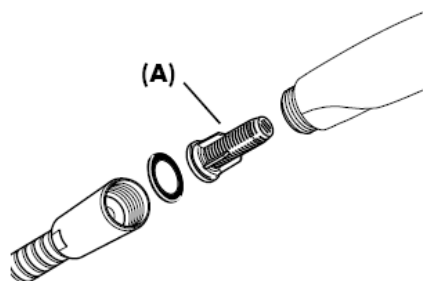

Justering

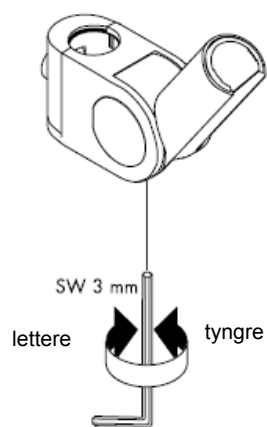
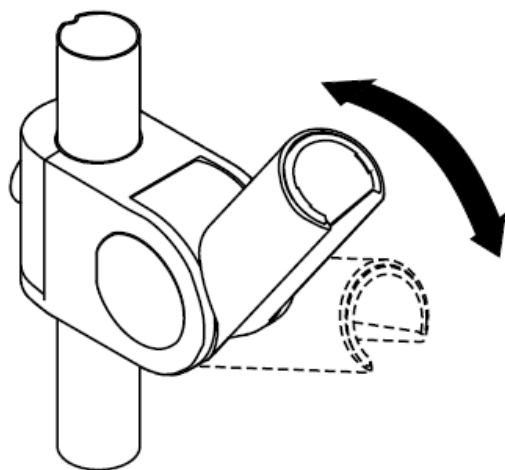
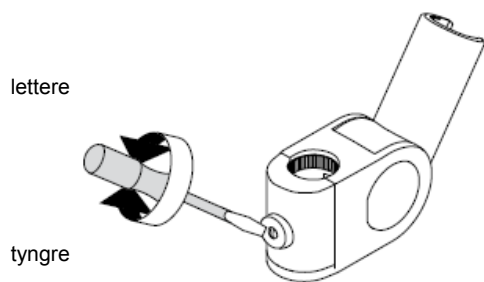
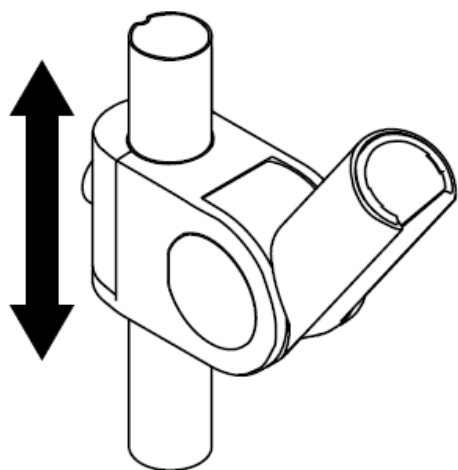

Rengjøring

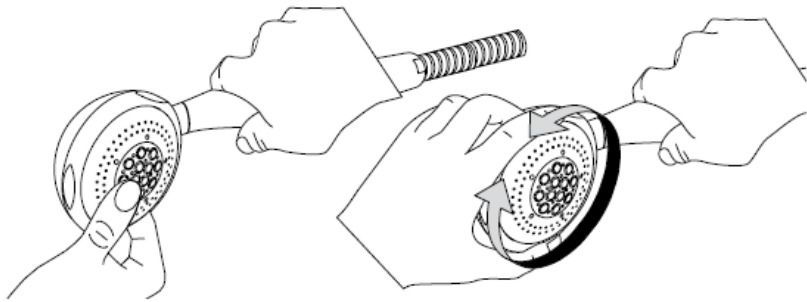

Ved hjelp av Rubit®, en manuell rengjøringsfunksjon, kan man fjerne kalk fra stråleformere ved enkel gnikking.



Stellveiledning

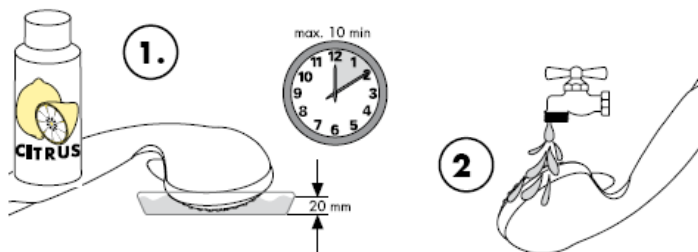

Rengjøring

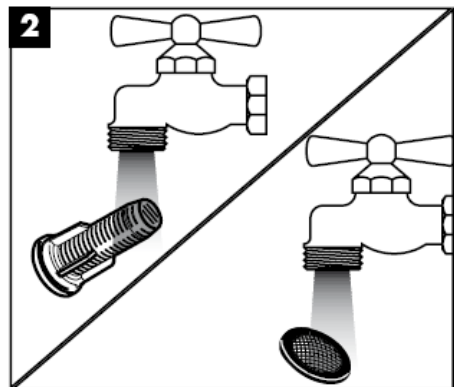
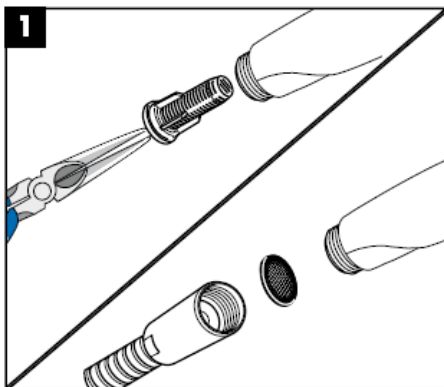
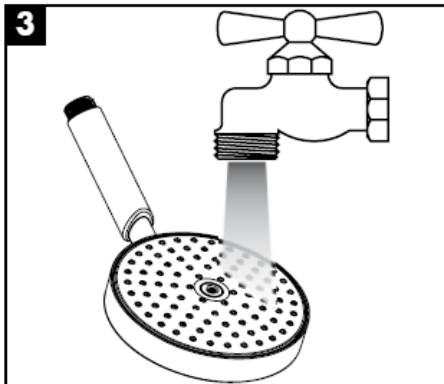
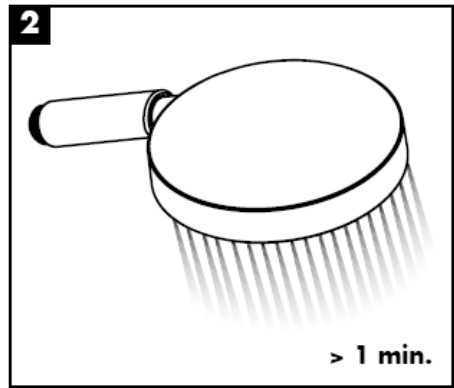
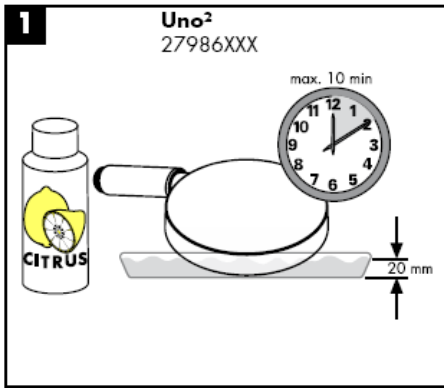

hansgrohe

РЪКОВОДСТВО ЗА МОНТАЖ

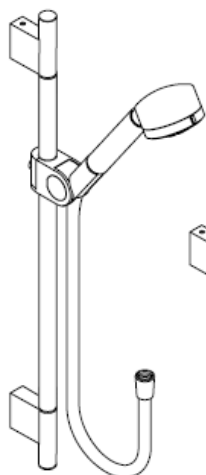

Uno/Arco
27985XXX

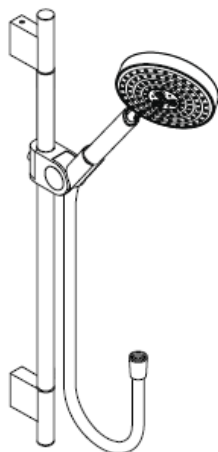

Uno²
27986XXX

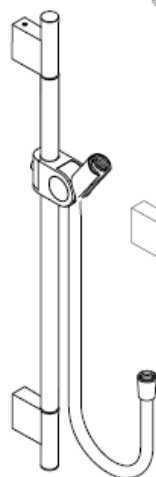

Uno
27989XXX

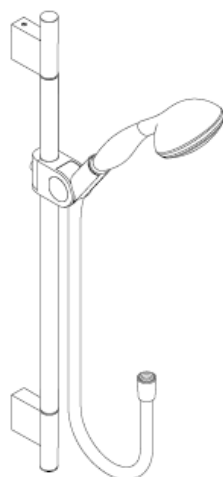

Allegroh
27956000

AXOR®

hansgrohe

Uno/Arco 27985XXX

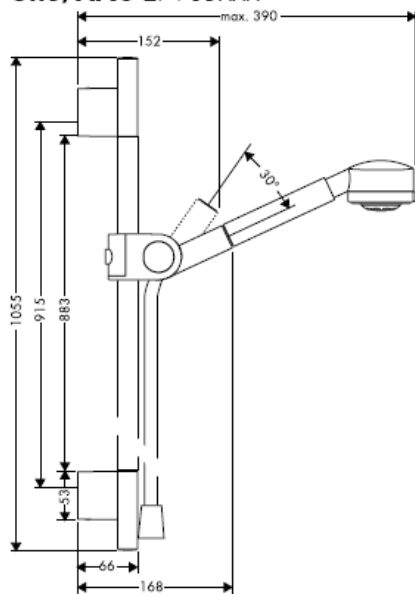

Uno² 27986XXX

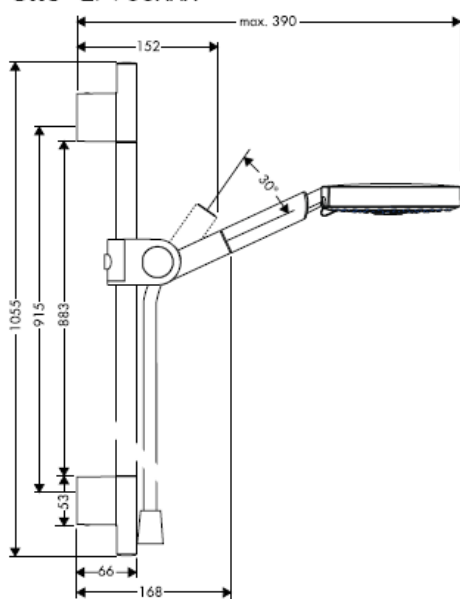

Uno 27989XXX

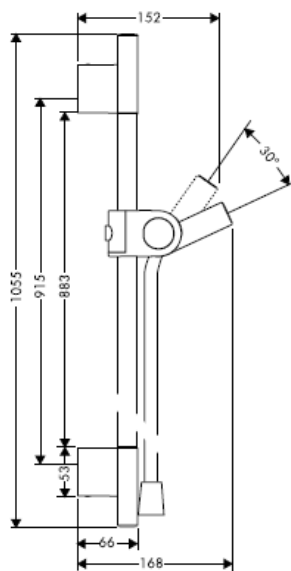

Allegroh 27956000

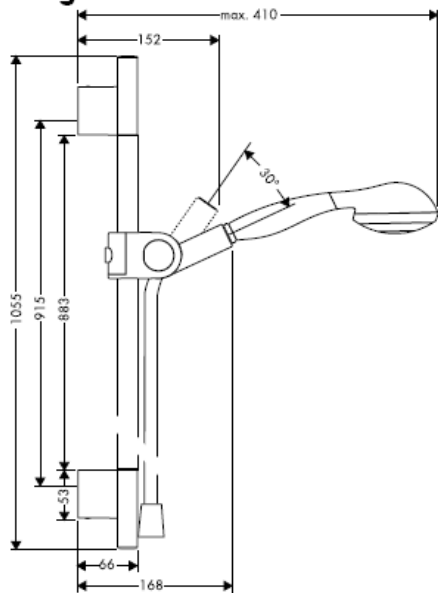



Оптималното функциониране се гарантира само във връзка с ръчните разпръскватели и маркучите на разпръскватели на Hansgrohe. Маркучите на разпръсквателите са подходящи само за свързване на разпръскватели към арматури. Не се допуска блокиране след маркуча по посоката на протичане!

Технически данни

Работно налягане: max. 0,6 MPa
Препоръчително работно налягане: 0,1 – 0,4 MPa
(1 MPa = 10 bar = 147 PSI)
Температура на горещата вода: max. 60° C

Ръчният разпръсквател е подходящ за използване с проточни нагреватели с мощност от 21 kW нагоре и минимален поток от 7 л/мин.

Uno/Arco 27985XXX

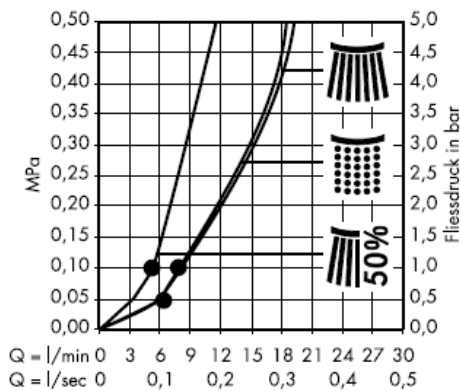
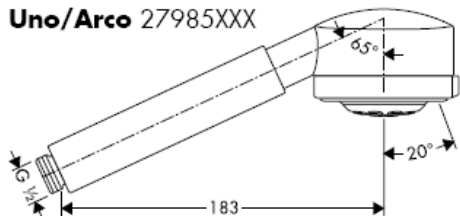

Нормална струя



Мека струя



Струя Есо

Allegroh 27956000

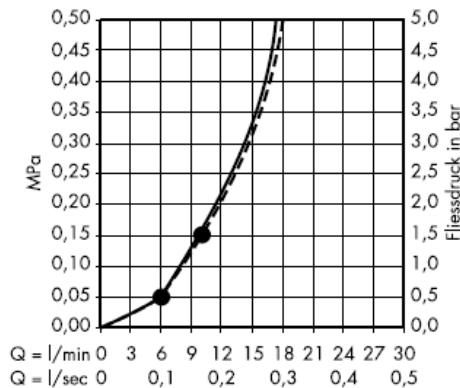
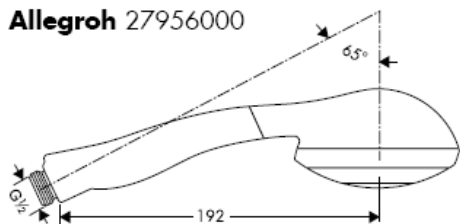

Нормална струя



Мека струя

Uno² 27986XXX

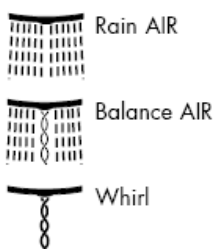
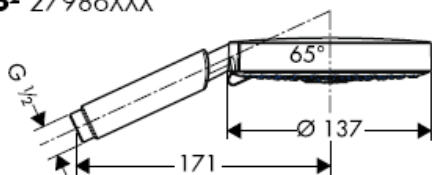

С филтърна вложка (A)

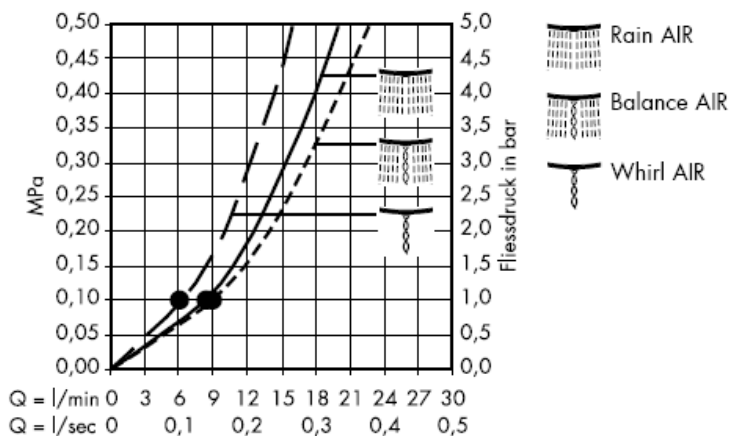

С уплътнение с цедка (B)

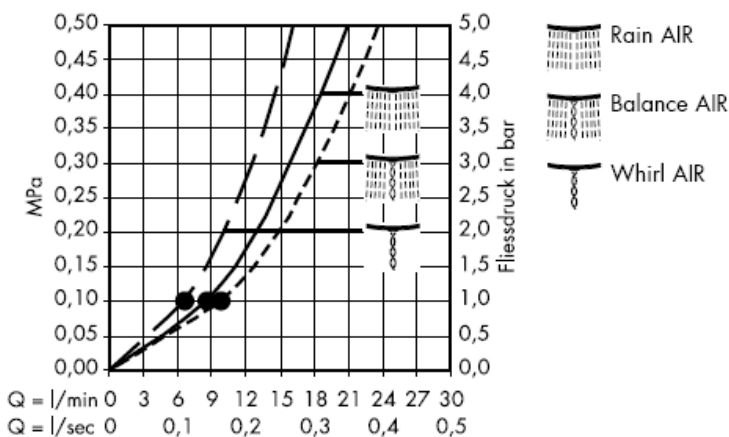

От • функцията е гарантирана.

Изравнете по възможност към растера на плочките.

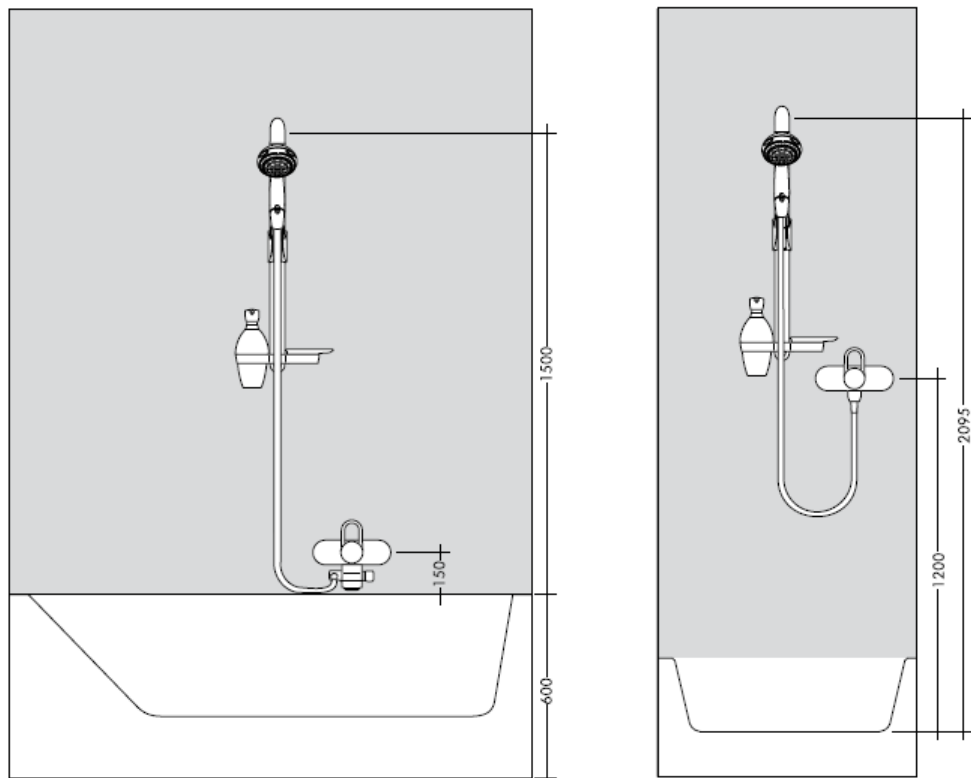

При монтаж на продукта от квалифицирани специалисти да се внимава за това, закрепващата повърхност в целия диапазон на закрепването да бъде равна (без изпъкнали фуги или изместване на плочки), конструкцията на стената да е подходяща за монтаж на продукта и особено за това, да няма слаби места. Приложените винтове и дюбели са подходящи само за бетон. При други стенни конструкции да се спазват данните на производителя на дюбели.

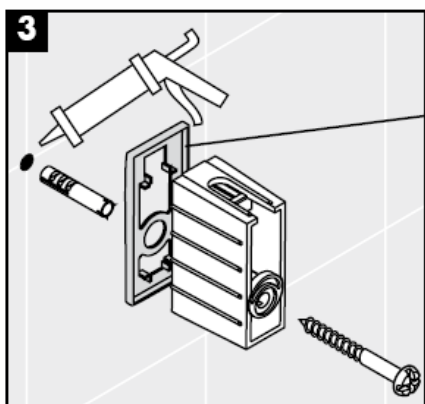
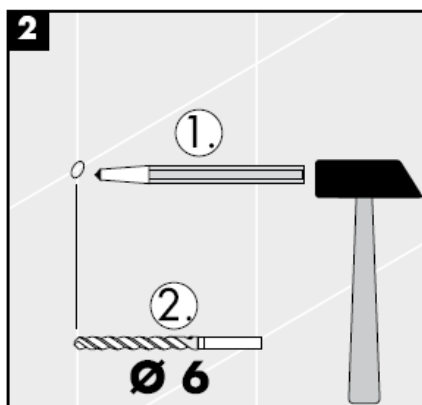
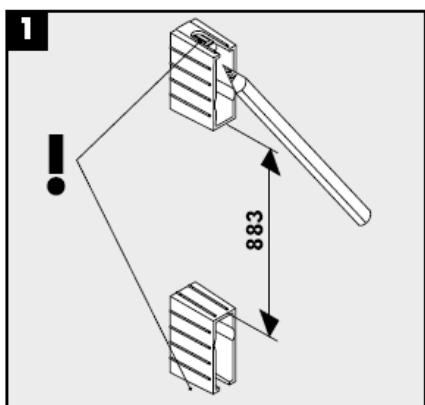

Декоративен пръстен само при вариант хром/ злато!

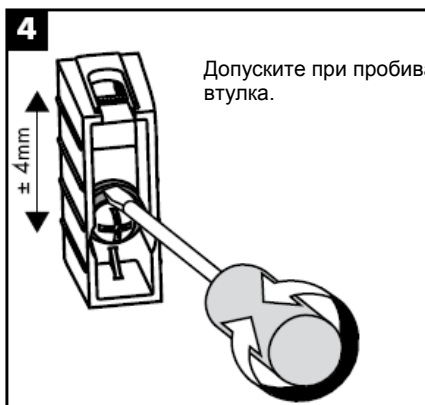

Допуските при пробиване могат да се изравнят с ексцентричната втулка.

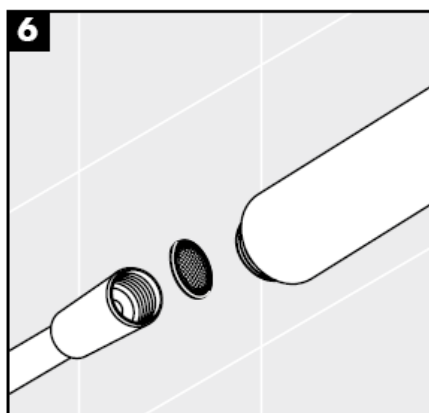
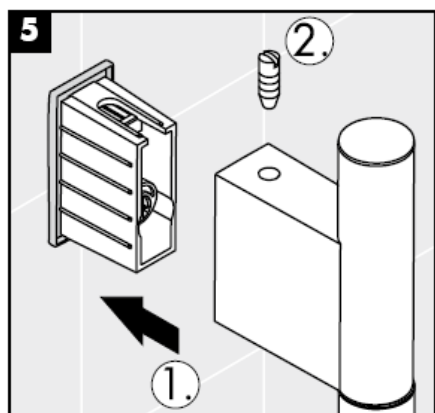

Опакованото заедно с разпръсквателя уплътнение с цедка трябва да се монтира, за да се избегне натрупване на замърсявания от водопроводната мрежа. Натрупването на замърсявания може да наруши функцията и/или да доведе до увреждания на функционалните части на разпръсквателя, Hansgrohe не носи отговорност за получените се по този начин щети.

Опакованата към него филтърна вложка (A) трябва да се монтира, за да се осигури нормалния поток към ръчния разпръсквател и да се избегне натрупване на замърсявания от водопроводната мрежа. Ако желаете по-силно протичане на вода, вместо филтърната вложка (A) поставете уплътнението с цедка (B). Натрупването на замърсявания може да наруши функцията и/или да доведе до увреждания на функционалните части на ръчния разпръсквател, Hansgrohe не носи отговорност за получените се по този начин щети.

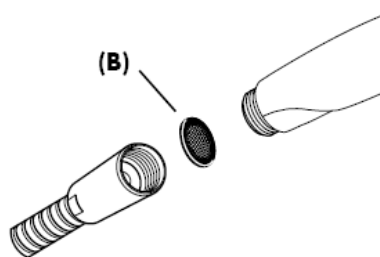
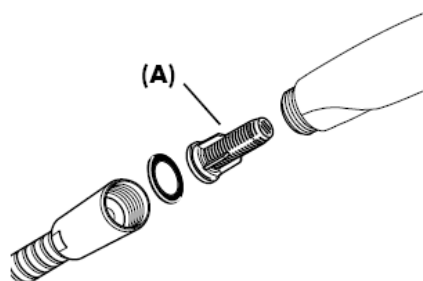

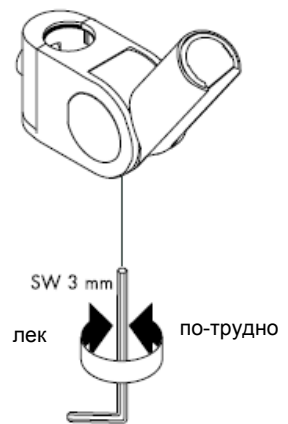
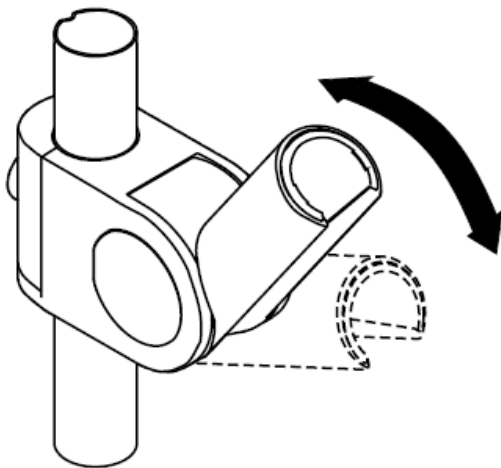
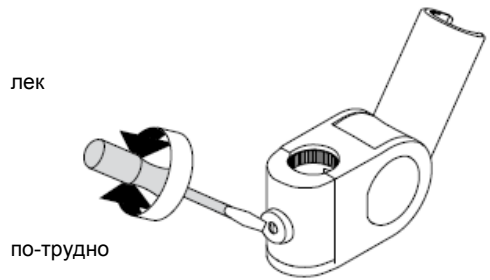
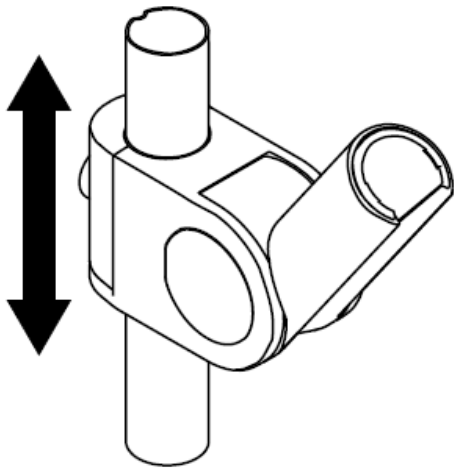

Почистване

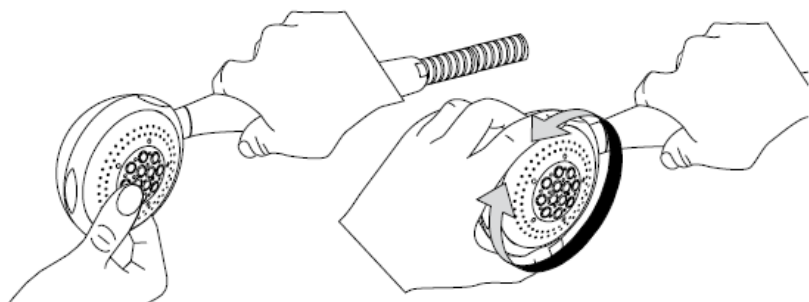

С Rubit®, ръчната функция за почистване, приспособенията за почистване на струята могат да се почистват от варовика с просто разтъркване.

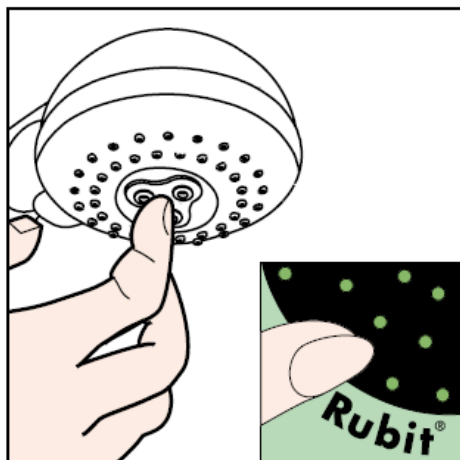

Инструкция за поддръжка

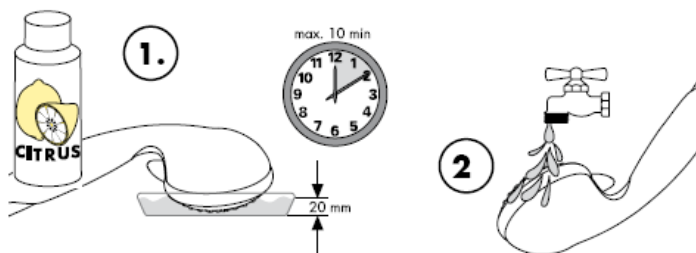

Почистване

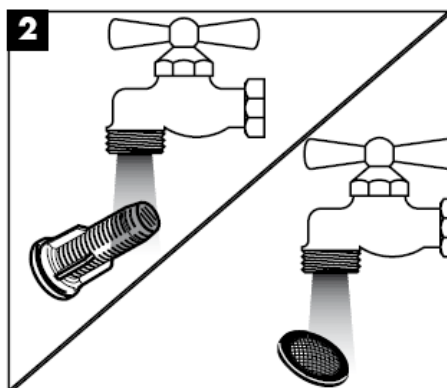
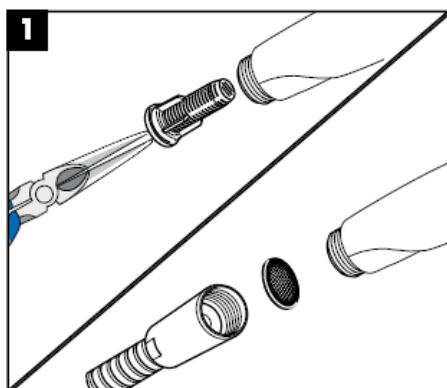
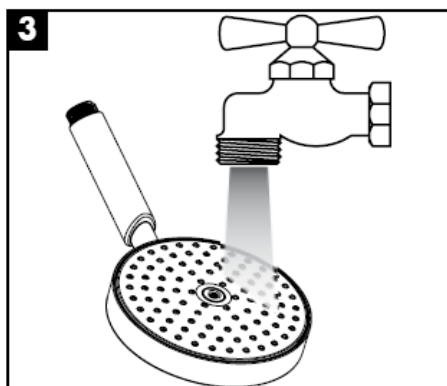
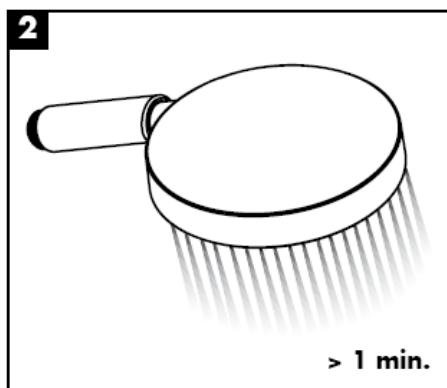
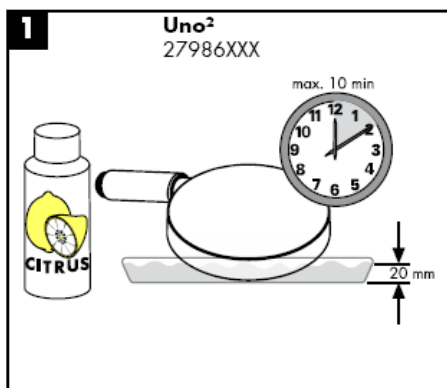

hansgrohe

Udhëzime rreth montimit

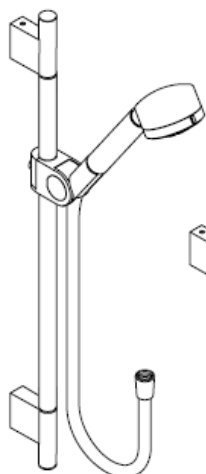

Uno/Arco
27985XXX

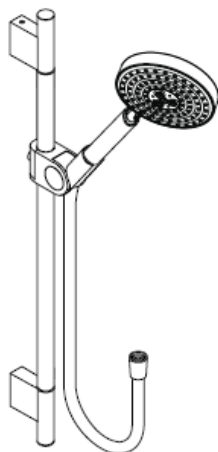

Uno²
27986XXX

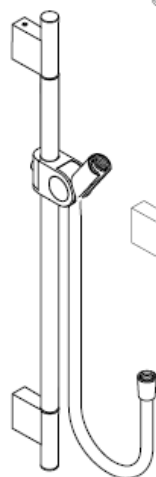

Uno
27989XXX

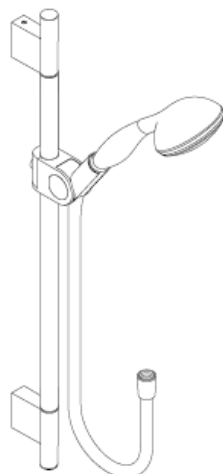

Allegroh
27956000

AXOR®

hansgrohe

Uno/Arco 27985XXX

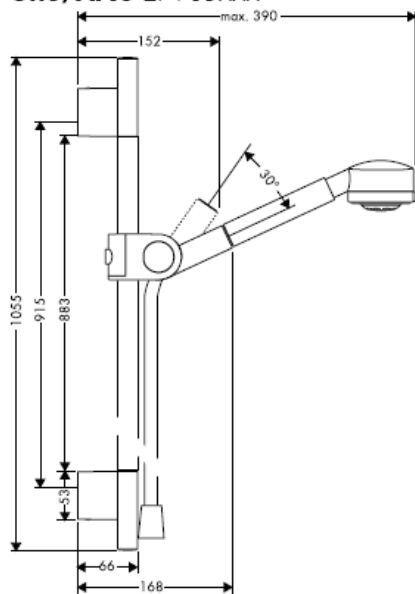

Uno² 27986XXX

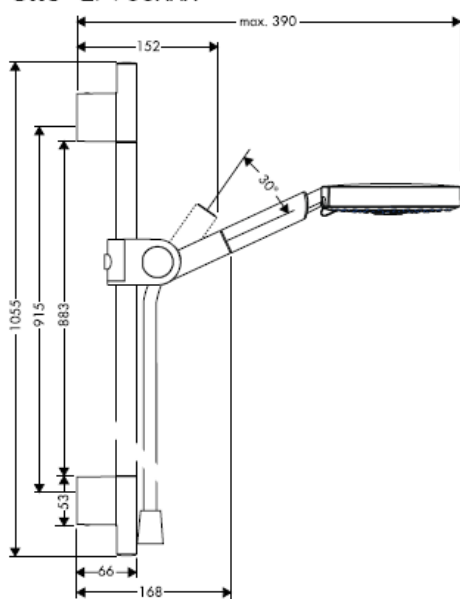

Uno 27989XXX

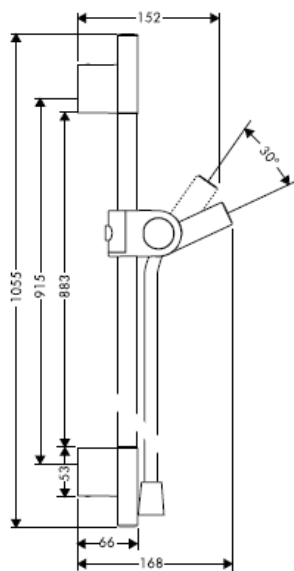

Allegroh 27956000

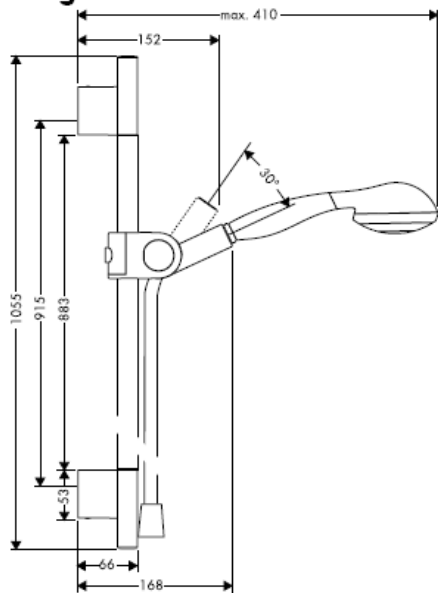



Garantohet funksioni optimal vetëm në kombinim me spërkatëset Hansgrohe si dhe zorrat e dushit Hansgrohe. Zorra e dushit mund të përdoren vetëm për lidhjen e spërkatëseve me armaturën. Ndalohet bllokimi pas zorrës në drejtim të rrjedhjes!

Të dhëna teknike

Presioni gjatë punës	max. 0,6 MPa
Presioni i rekomanduar: (1 MPa = 10 bar = 147 PSI)	0,1 – 0,4 MPa
Temperatura e ujit të ngrrohtë	max. 60° C

Spërkatësja mund të përdoret në kombinim me ngrohës elektrikë të ujit me kapacitet 21 kW e sipër dhe një rrjedhje minimale prej 7 l/min.

Uno/Arco 27985XXX

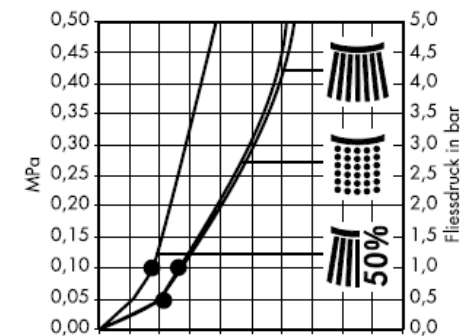
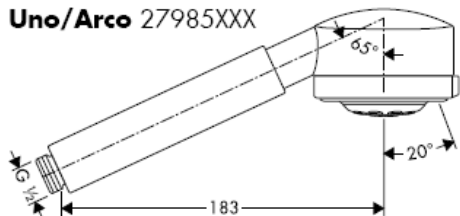

Curril normal



Currili i butë



Currili ekologjik

Allegroh 27956000

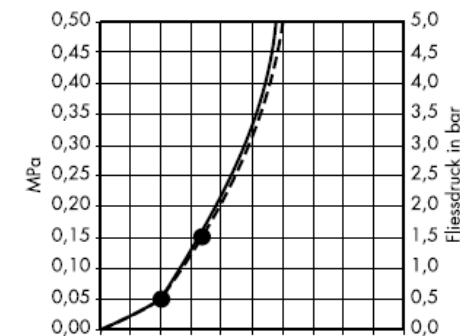
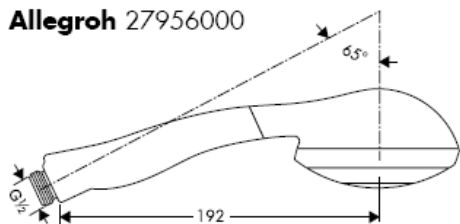

Curril normal



Currili i butë

Uno² 27986XXX

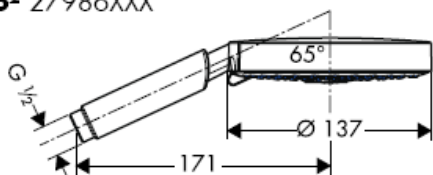

Rain AIR



Balance AIR



Whirl



Me përdorim të filtrit (A)

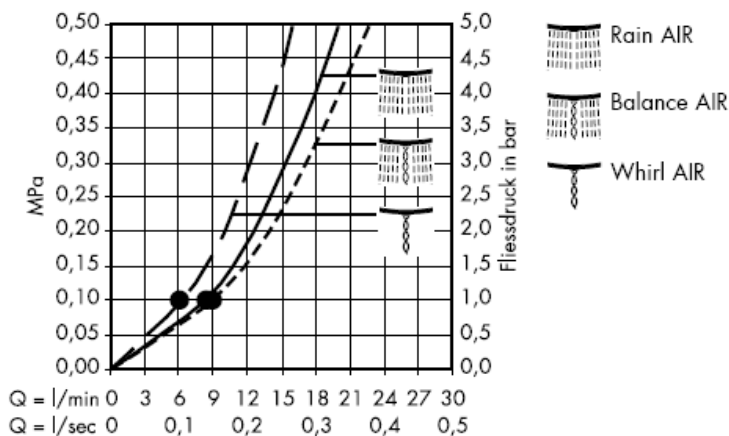

Me izolues të sitës (B)

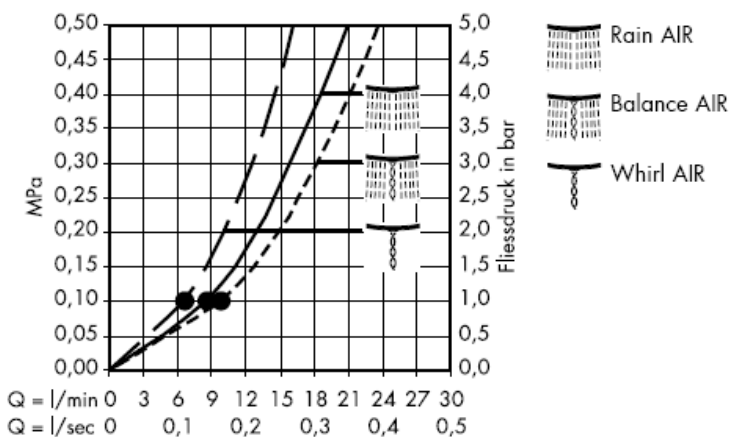

Nga është i mundur funksioni.

Përmasat i duhen përshtatur mundësisht këndit të pllakave të murit

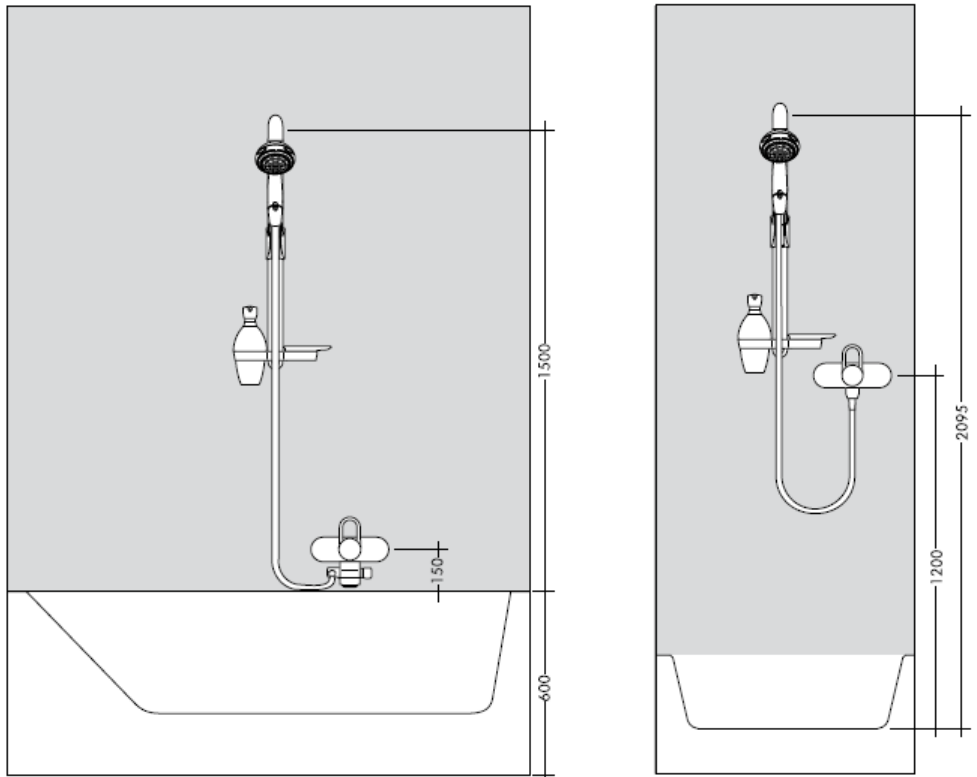

Gjatë montimit të produktit nga ana e personit të kualifikuar duhet pasur parasysh që e gjithë sipërfaqja mbërthyesë të jetë e drejtë (nuk duhet të ketë hapësira mes pllakave). Mbi të gjitha muri duhet të jetë i përshtatshëm për montim dhe nuk duhet të ketë pika të dobëta. Vidhat dhe kunjat e bashkangjitura janë të përshtatshme vetëm për beton. Te përbërja tjetër murore të merren parasysh të dhënat e prodhuesit të kunjave.

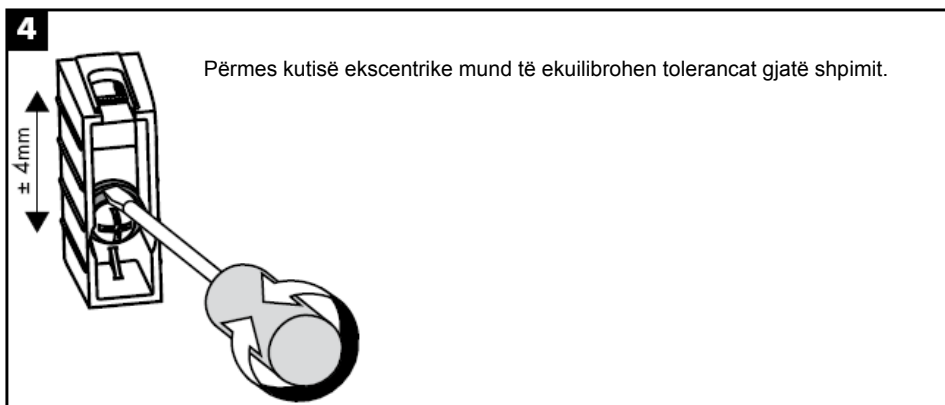
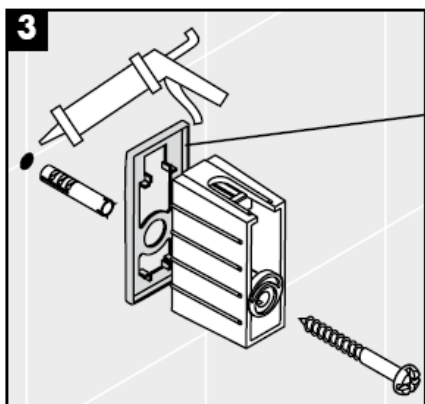
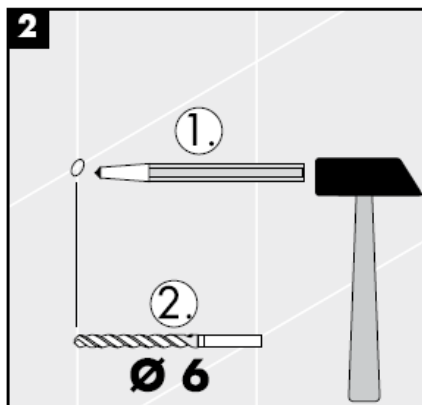
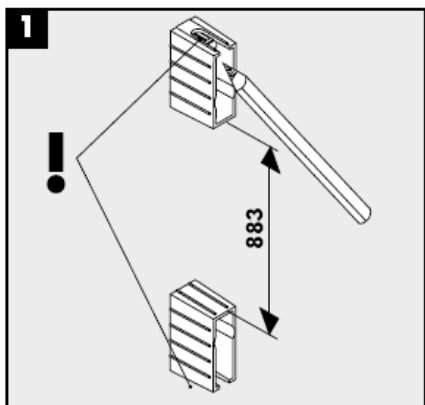

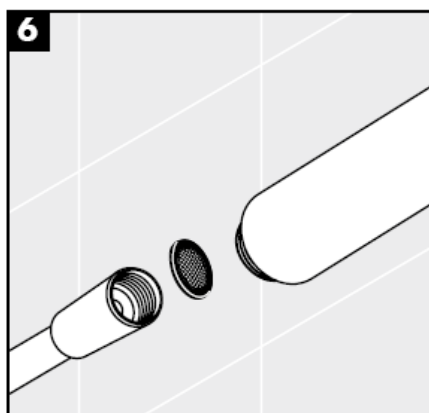
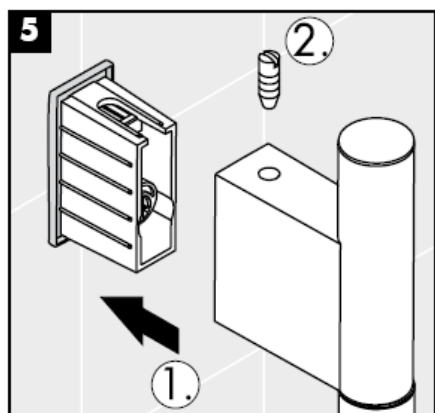

Sita që i kemi bashkëngjitur spërkatëses duhet përdorur për të evituar thithjen e papastërtive nga rrjeti i ujësjellësit. Ndotjet mund të dëmtojnë pjesë funksionale të spërkatëses. Hansgrohe nuk merr përgjegjësinë për dëmet e shkaktuara në këtë mënyrë.

Filtri i bashkëngjitur (A) duhet montuar për të garantuar rrjedhjen sipas normave të ujit nga spërkatësja si dhe për të evituar thithjen e ndotjeve nga tubacionet e ujësjellësit. Nëse dëshironi më shumë vëllim uji, atëherë në vend të filtrit (A) duhet të përdorni sitën (B).

Ndotjet mund të dëmtojnë pjesë funksionale të spërkatëses. Hansgrohe nuk merr përgjegjësinë për dëmet e shkaktuara në këtë mënyrë.

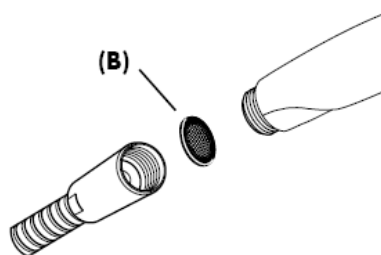
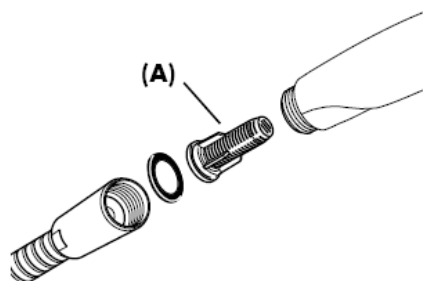

Justimi

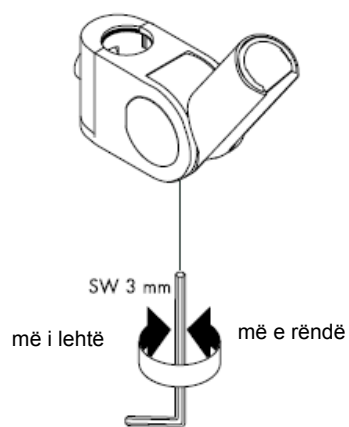
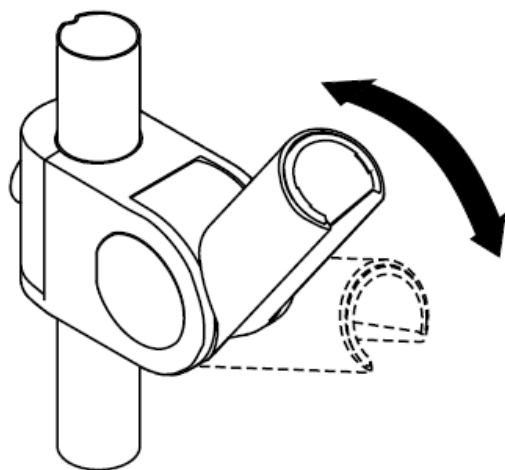
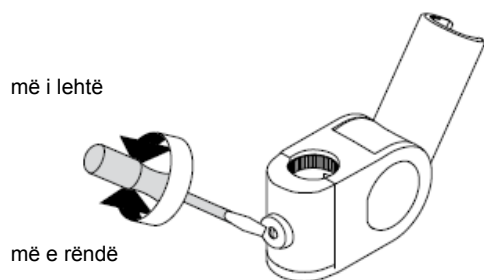
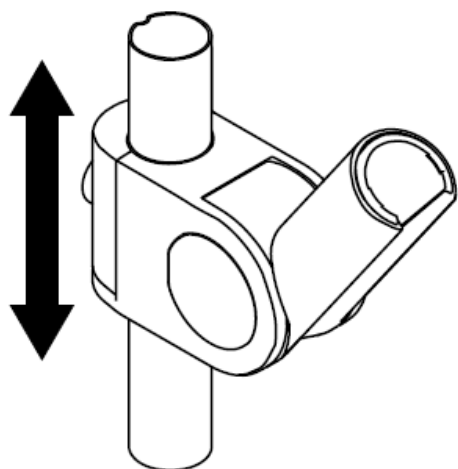

Pastrimi

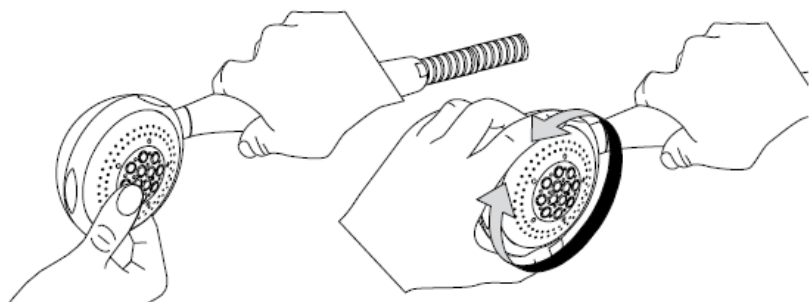

Me Rubit®, funksionin manual të pastrimit mund të hiqet kalku me fërkim të thjeshtë nga formuesit e currilit.



Udhëzime rreth mirëmbajtjes

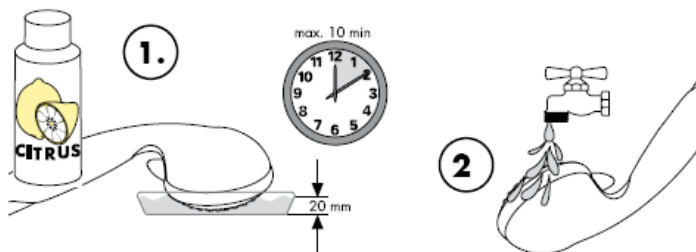

Pastrimi

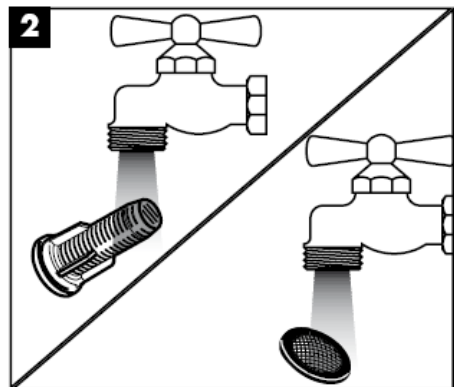
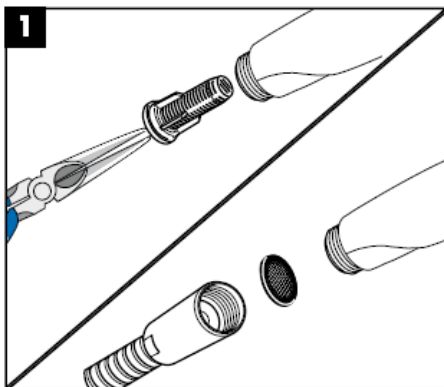
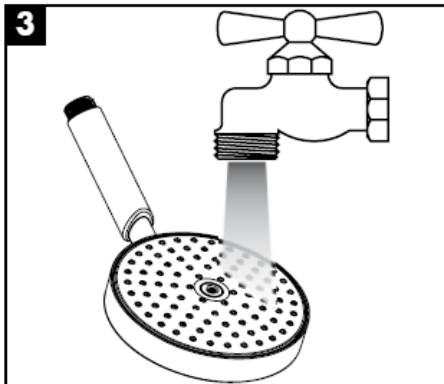
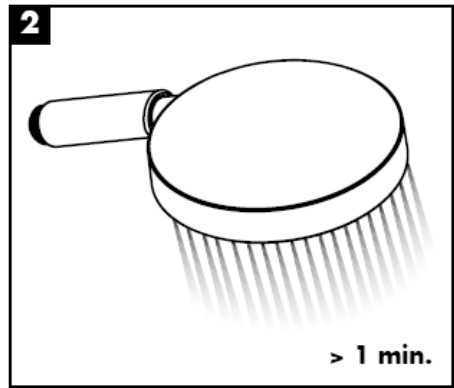
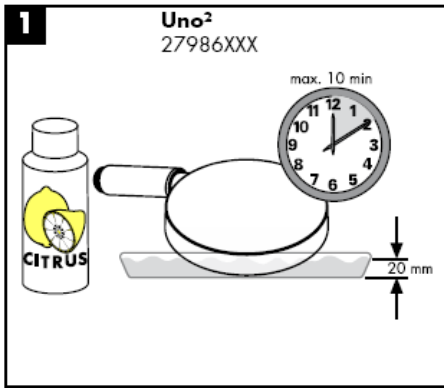

hansgrohe

