

DE	Gebrauchsanleitung / Montageanleitung	2
FR	Mode d'emploi / Instructions de montage	3
EN	Instructions for use / assembly instructions	4
IT	Istruzioni per l'uso / Istruzioni per l'installazione	5
ES	Modo de empleo / Instrucciones de montaje	6
NL	Gebruiksaanwijzing / Handleiding	7
DK	Brugsanvisning / Monteringsvejledning	8
PT	Instruções para uso / Manual de Instalação	9
PL	Instrukcja obsługi / Instrukcja montażu	10
CS	Návod k použití / Montážní návod	11
SK	Návod na použitie / Montážny návod	12
ZH	用户手册 / 组装说明	13
RU	Руководство пользователя / Инструкция по монтажу	14
HU	Használati útmutató / Szerelési útmutató	15
FI	Käyttöohje / Asennusohje	16
SV	Bruksanvisning / Monteringsanvisning	17
LT	Vartotojo instrukcija / Montavimo instrukcijos	18
HR	Upute za uporabu / Uputstva za instalaciju	19
TR	Kullanım kılavuzu / Montaj kılavuzu	20
RO	Manual de utilizare / Instrucțiuni de montare	21
EL	Οδηγίες χρήσης / Οδηγία συναρμολόγησης	22
SL	Navodilo za uporabo / Navodila za montažo	23
ET	Kasutusjuhend / Paigaldusjuhend	24
LV	Lietošanas pamācība / Montāžas instrukcija	25
SR	Uputstvo za upotrebu / Uputstvo za montažu	26
NO	Bruksanvisning / Montasjeveiledning	27
BG	Инструкция за употреба / Инструкция за употреба	28
SQ	Udhëzuesi i përdorimit / Udhëzime rreth montimit	29
AR	دليل الاستخدام / تعليمات التجميع	30

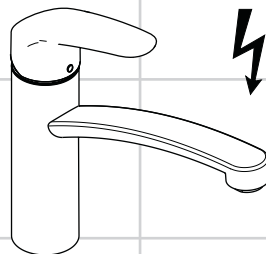

Focus E²
31804000

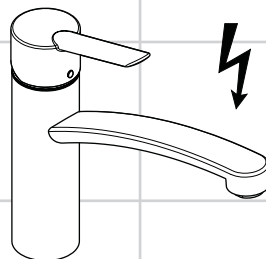

Focus S
31785000

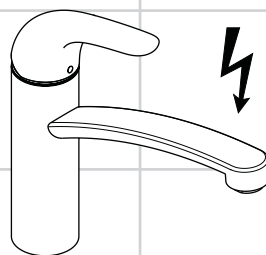

Focus E
31784000



Sicherheitshinweise

- Bei der Montage müssen zur Vermeidung von Quetsch- und Schnittverletzungen Handschuhe getragen werden.

Montagehinweise

- Die Armatur muss nach den gültigen Normen montiert, gespült und geprüft werden!
- Achtung! * Bei 5 Liter Geräten darf die Auslaufleistung am Mischer 5 l/min nicht übersteigen. Gegebenenfalls Wasserzufuhr am Eckventil regulieren.

Technische Daten

Betriebsdruck:	max. 1 MPa
Empfohlener Betriebsdruck: (1 MPa = 10 bar = 147 PSI)	0,1 - 0,5MPa
Heißwassertemperatur:	max. 80 °C
Empfohlene Heißwassertemperatur:	65 °C
Durchflussleistung:	max. 5 l/min

Symbolerklärung



Kein essigsäurehaltiges Silikon verwenden!



Wartung (siehe Seite 36)

- Rückflussverhinderer müssen gemäß DIN EN 1717 regelmäßig in Übereinstimmung mit nationalen oder regionalen Bestimmungen (DIN 1988 einmal jährlich) auf ihre Funktion geprüft werden.
- Wird der Strahlformer gewechselt, muss ein für diese Armatur zugelassener Strahlformer verwendet werden.



Maße (siehe Seite 33)



Serviceteile (siehe Seite 35)



Bedienung (siehe Seite 34)

Beim Aufheizen des Wasserspeichers tritt am Auslauf Tropfwasser aus.



Reinigung

Reinigung siehe beiliegende Broschüre.



Prüfzeichen (siehe Seite 32)

Störung

Ursache

Abhilfe

Wenig Wasser	- Strahlformer verkalkt, verschmutzt	- Strahlformer reinigen, ggf. austauschen
	- Schmutzfangsieb in den Eckventilen verschmutzt.	- Schmutzfangsieb reinigen / austauschen
Armatur schwergängig	- Kartusche defekt, verkalkt	- Kartusche austauschen
Armatur tropft ständig bei ausgeschaltetem Wasserbereiter	- Kartusche defekt	- Kartusche austauschen
Wasseraustritt im Bereich des Schwenkauslaufes	- O-Ring defekt	- O-Ring austauschen
Wasseraustritt am Befestigungsschaft	- Adapterboden undicht	- Adapterboden prüfen, gegebenenfalls austauschen
	- O-Ring am Anschluss Schlauch defekt	- O-Ring austauschen
Wasseraustritt unter dem Griff	- Kartusche defekt	- Kartusche austauschen



Montage siehe Seite 31



Consignes de sécurité

- ⚠ Lors du montage, porter des gants de protection pour éviter toute blessure par écrasement ou coupure

Instructions pour le montage

- La robinetterie doit être installée, rincée et contrôlée conformément aux normes valables!
- Attention!* Sur les chauffe-eau à contenance de 5 litres le débit ne doit pas dépasser 5l/min, dans ce cas là, réduire le débit avec le robinet d'arrêt et d'équerre.

Informations techniques

Pression de service autorisée:	max. 1 MPa
Pression de service conseillée: (1 MPa = 10 bar = 147 PSI)	0,1 - 0,5MPa
Température d'eau chaude:	max. 80 °C
Température recommandée:	65 °C
Débit:	max. 5 l/min

Description du symbole



Ne pas utiliser de silicone contenant de l'acide acétique!



Entretien (voir page 36)

- Les clapets anti-retour doivent être examinés régulièrement conformément à la norme EN 1717 ou conformément aux dispositions nationales ou régionales quant à leur fonction (au moins une fois par an).
- Si l'on change le aérateur, il faudra utiliser un aérateur normalisé pour cette robinetterie.



Dimensions (voir page 33)



Pièces détachées (voir pages 35)



Instructions de service (voir page 34)

When the storage tank is being heated, the spout will drip.



Nettoyage

Pour les conseils d'entretien, voir la brochure ci-jointe.



Classification acoustique et débit (voir page 32)

Dysfonctionnement

Origine

Solution

Pas assez d'eau

- Mousseur entartré ou encrassé

- Nettoyer le mousseur ou le changer éventuellement

- Filtre du robinet d'arrêt encrassé.

- Nettoyez / changez le filtre

Dureté de fonctionnement

- Cartouche défectueuse, entartrée

- Changer le cartouche

Le mitigeur goutte sans arrêt avec un chauffe-eau hors-service

- Cartouche défectueuse

- Changer le cartouche

Fuite à l'embase du bec

- Joint torique défectueux

- Changer le joint torique

Fuite à la fixation sous le mitigeur

- Manque d'étanchéité du fond de l'adaptateur

- Vérifier le fond de l'adaptateur, le remplacer si nécessaire

- Joint torique sous les flexible de raccords défectueux

- Changer le joint torique

Fuite d'eau sous la poignée

- Cartouche défectueuse

- Changer le cartouche



Montage voir page 31



Safety Notes

- ⚠️ Gloves should be worn during installation to prevent crushing and cutting injuries.

Installation Instructions

- The fitting must be installed, flushed and tested after the valid norms!
- Important! * With water heaters of 5 liters the flow rate at the mixer should not exceed 5 l/min.
- In this case the flow rate must be reduced at the isolation valve.

Technical Data

Operating pressure:	max. 1 MPa
Recommended operating pressure: (1 MPa = 10 bar = 147 PSI)	0,1 - 0,5MPa
Hot water temperature:	max. 80°C
Recommended hot water temp.:	65°C
Rate of flow:	max. 5 l/min

Symbol description



Do not use silicone containing acetic acid!



Maintenance (see page 36)

- The non return valves must be checked regularly according to DIN EN 1717 in accordance with national or regional regulations (at least once a year).
- When changing the spray former, it is imperative to use one made for this type of mixer.



Dimensions (see page 33)



Spare parts (see page 35)



Operation (see page 34)

When the storage tank is being heated, the spout will drip.



Cleaning

Cleaning recommendations, see enclosed brochure.



Test certificate (see page 32)

Fault	Cause	Remedy
Insufficient water	- Spray former calcified, dirty	- Clean spray former, exchanging if necessary
	- Filter at the isolation valves soils.	- Clean the filter / exchange filter
Mixer stiff	- Cartridge defective, calcified	- Exchange cartridge
Mixer dripping constantly with water heater switched off	- Cartridge defective	- Exchange cartridge
Water escaping in area of swivel spout	- O-ring defective	- Exchange O-ring
Water escaping at the threaded base	- Adapter floor leaks	- Check the adapter floor, replace if necessary
	- O-ring at the connection hose defective.	- Exchange O-ring
Water escaping below handle	- Cartridge defective	- Exchange cartridge



Assembly see page 31



Indicazioni sulla sicurezza

- ⚠ Durante il montaggio, per evitare ferite da schiacciamento e da taglio bisogna indossare guanti protettivi.

Istruzioni per il montaggio

- La rubinetteria deve essere installata, pulita e testata secondo le istruzioni riportate!
- **Attenzione!*** Nel caso di apparecchi da 5 litri l'erogazione del miscelatore non deve superare i 5 l/min. Eventualmente strozzare l'alimentazione d'acqua del rubinetto a squadra.

Dati tecnici

Pressione d'uso:	max. 1 MPa
Pressione d'uso consigliata: (1 MPa = 10 bar = 147 PSI)	0,1 - 0,5MPa
Temperatura dell'acqua calda:	max. 80 °C
Temp. dell'acqua calda consigliata:	65 °C
Portata di erogazione:	max. 5 l/min

Descrizione simbolo



Non utilizzare silicone contenente acido acetico!



Manutenzione (vedi pagg. 36)

- La valvola di non ritorno deve essere controllata regolarmente come da DIN EN 1717, secondo le normative nazionali e regionali (almeno una volta all'anno).
- Se si cambia il rompigitto, per questo rubinetto deve venir usato un rompigitto idoneo.



Ingombri (vedi pagg. 33)



Parti di ricambio (vedi pagg. 35)



Procedura (vedi pagg. 34)

Durante il riscaldamento del serbatoio d'acqua all'uscita si ha uno stillicidio.



Pulitura

Suggerimenti per la pulizia: vedi il prospetto accluso.



Segno di verifica (vedi pagg. 32)

Problema	Possibile causa	Rimedio
Scarsità d'acqua	- diffusore del getto difettosa, pieno di calcare	- Pulire oppure sostituire il diffusore del getto
	- Filtro sporco nelle valvole ad angolo.	- Pulire / sostituire il filtro
Miscelatore duro	- Cartuccia difettosa	- Sostituire la cartuccia
Il miscelatore perde acqua di continuo con la caldaia spenta	- Cartuccia difettosa	- Sostituire la cartuccia
Perdita di acqua intorno all'erogazione girevole	- O-ring difettoso	- Sostituire l'o-ring
Perdita di acqua al set di fissaggio	- Fondo dell'adattatore non ermetico	- Controllare il fondo dell'adattatore, eventualmente sostituire
	- O-ring al raccordo flessibile difettoso	- Sostituire l'o-ring
Perdita d'acqua al di sotto della maniglia	- Cartuccia difettosa	- Sostituire la cartuccia





Indicaciones de seguridad

- ⚠ Durante el montaje deben utilizarse guantes para evitar heridas por aplastamiento o corte.

Indicaciones para el montaje

- El grifo tiene que ser instalado, probado y testado, según las normas en vigor.
- ¡Atención!* En caso de utilizar un calentador de 5 litros de capacidad el caudal de agua que pasa por el mezclador, no debe superar 5 l/min. En caso necesario, disminuir la entrada del agua por medio de la llave de escuadra.

Datos técnicos

Presión en servicio:	max. 1 MPa
Presión recomendada en servicio: (1 MPa = 10 bar = 147 PSI)	0,1 - 0,5MPa
Temperatura del agua caliente:	max. 80 °C
Temp. recomendada del agua caliente:	65 °C
Caudal máximo:	max. 5 l/min

Descripción de símbolos



No utilizar silicona que contiene ácido acético!



Mantenimiento (ver página 36)

- Las válvulas anti-retorno tienen que ser controladas regularmente según la norma DIN EN 1717, en acuerdo con las regulaciones nacionales o regionales (una vez al año, por lo menos).
- En caso de cambiar el aireador, hay que utilizar un aireador adecuado para este tipo de grifería.



Dimensiones (ver página 33)



Repuestos (ver página 35)



Manejo (ver página 34)

Al calentar el depósito de agua suelen desbordarse de la salida siempre unas gotas de agua.



Limpiar

Para las instrucciones de limpieza, ver el folleto adjunto.



Marca de verificación (ver página 32)

Problema	Causa	Solución
Sale poca agua	- Formador de chorro ensuciado, calcificado	- Limpiar o cambiar el formador de chorro
	- Filtro colector de suciedad en las válvulas angulares ensuciado.	- limpiar/cambiar el filtro
Manecilla va dura	- cartucho dañado	- cambiar el cartucho
Grifo pierde continuamente agua con calientaaguas apagado	- cartucho dañado	- cambiar el cartucho
Pérdida de agua en el caño giratorio	- junta dañado	- cambiar juntas
Pérdida de agua en el set de fijación	- Adaptador de suelo presenta fugas	- Comprobar adaptador de suelo. Si es necesario, cambiar
	- Daños en la junta de la conexión flexible	- cambiar juntas
Pérdida de agua en el mando	- cartucho dañado	- cambiar el cartucho





Veiligheidsinstructies

-  Bij de montage moeten ter voorkoming van knel- en snijwonden handschoenen worden gedragen.

Montage-instructies

- Leidingen doorspoelen volgens Norm. De mengkraan vervolgens monteren en controleren!
- **Attentie!*** Bij toestellen van 5 liter mag de uitloopcapaciteit aan de mengkraan niet hoger zijn dan 5 l/min. Indien nodig moet de watertoevoer aan de hoekstopkraan geregeld worden.

Technische gegevens

Werkdruk: max.	max. 1 MPa
Aanbevolen werkdruk: (1 MPa = 10 bar = 147 PSI)	0,1 - 0,5MPa
Temperatuur warm water:	max. 80 °C
Aanbevolen warm water temp.:	65 °C
Doorstroomcapaciteit:	max. 5 l/min

Symboolbeschrijving



Gebruik geen zuurhoudende silicone!



Onderhoud (zie blz. 36)

- Keerleppele moeten volgens DIN EN 1717 regelmatig en volgens plaatselijk geldende eisen op het functioneren gecontroleerd worden. (Tenminste een keer per jaar).
- Indien de straaltvormer vervangen wordt, moet een straaltvormer gebruikt worden die is toegelaten voor deze armatuur.



Maten (zie blz. 33)



Service onderdelen (zie blz. 35)



Bediening (zie blz. 34)

Bij het opwarmen van het waterreservoir ontsnapt aan de uitloop drupwater.



Reinigen

Reinigingsadvies zie bijgevoegde brochure.



Keurmerk (zie blz. 32)

Storing

Oorzaak

Oplossing

Weinig water	- Straalopeningen verkalkt, vuil	- Straalopeningen reinigen, indien nodig vervangen
	- Vuilvangzeef bij de hoekstopkraan vervuild.	- Vuilvangzeef reinigen / uitwisselen
bediening zwaar	- Kardoes defect of verkalkt	- Kardoes uitwisselen
Armatuur drupt altijd bij een uitgeschakelde boiler	- Kardoes defect	- Kardoes uitwisselen
Lekkage tussen aansluiting uitloop en kraanhuis	- O-ring defect	- O-ring uitwisselen
Lekkage op montageschacht	- Adapterbodem ondticht	- Adapterbodem controleren, indien nodig vervangen
	- O-ring van aansluitslang defect	- O-ring uitwisselen
Lekkage op greep	- Kardoes defect	- Kardoes uitwisselen



Montage zie blz. 31



Sikkerhedsanvisninger

- ⚠ Ved monteringen skal der bruges handsker for at undgå kvæstelser og snitsår.

Monteringsanvisninger

- Ifølge gældende regler, skal armaturet monteres, skylles igennem og afprøves.
- Advarsel!* Ved 5 litres beholdere må udløbsydelsen ved håndvaskarmaturet ikke overstige 5 liter/min. I modsat fald drøles vandet ved vandtilførslen ved hjørneventilen.

Tekniske data

Driftstryk:	max. 1 MPa
Anbefalet driftstryk: (1 MPa = 10 bar = 147 PSI)	0,1 – 0,5MPa
Varmtvandstemperatur:	max. 80 °C
Anbefalet varmtvandstemperatur:	65 °C
Gennemstrømningskapacitet:	max. 5 l/min

Symbolbeskrivelse



Der må ikke benyttes eddikesyreholdig silikone!



Service (se s. 36)

- Ifølge DIN EN 1717 skal gennemstrømningsbegrænsere i overensstemmelse med nationale regler afprøves regelmæssigt (mindst en gang om året).
- Ved skift af stråleformer, skal der anvendes en stråleformer, som er godkendt til dette armatur



Målene (se s. 33)



Reservedele (se s. 35)



Brugsanvisning (se s. 34)

Ved opvarmning af varmtvandsbeholderen forekommer dryp fra udløbstudene.



Rengøring

For anbefalinger til rengøringen, se venligst den vedlagte brochure.



Godkendelse (se s. 32)

Fejl	Årsag	Hjælp
For lidt vand	- Stråleformer forkalket, tilsmudset	- Stråleformer renses, skiftes i givet fald ud
	- Smudsfangstierne ved stopventilen er tilstoppede.	- Rengør / udskift smudsfangstier
Grebet går trægt	- Kartusche defekt, tilkalket	- Udskift kartusche
Armatur drypper hele tiden ved slukket vandvarmer	- Defekt kartusche	- Udskift kartusche
Armaturet drypper ved svingtudene.	- Defekt o-ring	- Udskift o-ring
Armaturet er utæt ved befæstelsesdelene	- Adapterbund utæt	- Kontroller adapterbunden, udskift evt.
	- Defekt o-ring på tilslutningsslange	- Udskift o-ring
Armaturet drypper ved greb	- Defekt kartusche	- Udskift kartusche





Avisos de segurança

- ⚠ Durante a montagem devem ser utilizadas luvas de protecção, de modo a evitar ferimentos resultantes de entalamentos e de cortes.

Avisos de montagem

- A misturadora deve ser instalada, purgada e testada de acordo com as normas em vigor!
- Atenção! * Nos aparelhos de 5 litros a capacidade de saída na misturadora não pode exceder 5 l/min. Regular eventualmente a alimentação da água na torneira de esquadria.

Dados Técnicos

Pressão de funcionamento:	max. 1 MPa
Pressão de func. recomendada: (1 MPa = 10 bar = 147 PSI)	0,1 - 0,5MPa
Temperatura da água quente:	max. 80 °C
Temp. água quente recomendada:	65 °C
Caudal:	max. 5 l/min

Descrição do símbolo



Não utilizar silicone que contenha ácido acético!



Manutenção (ver página 36)

- As válvulas anti-retorno devem ser verificadas regularmente de acordo com a DIN EN 1717 segundo os regulamentos nacionais ou regionais (pelo menos uma vez por ano).
- Se o emulsor for substituído é necessário utilizar um emulsor adequado para esta torneira.



Medidas (ver página 33)



Peças de substituição (ver página 35)



Funcionamento (ver página 34)

Fuga de gotas de água durante o aquecimento do depósito de água.



Limpeza

Consultar a seguinte brochura sobre as recomendações de limpeza.



Marca de controlo (ver página 32)

Falha	Causa	Solução
Água insuficiente	- Emulsor com calcário, com sujidade	- Limpar emulsor, event. Substituir
	- Filtro da torneira de esquadria obstruído.	- Limpar / trocar o filtro
Misturadora perra	- Cartucho defeituoso, calcificado	- Substituir o cartucho
Misturadora pinga constantemente com preparador de água desligado	- Cartucho defeituoso	- Substituir o cartucho
Perde água na zona da bica rotativa	- O-ring defeituoso	- Trocar o-ring
Perde água pela base roscada	- Fundo do adaptador com fuga	- Controlar o fundo do adaptador e substituir, se necessário
	- O-ring dos tubo de ligação defeituoso	- Trocar o-ring
Perde água dos manípulo	- Cartucho defeituoso	- Substituir o cartucho





Wskazówki bezpieczeństwa

- ⚠ Aby uniknąć zranień, takich jak zgniecenia czy przecięcia, podczas montażu należy nosić rękawice.

Wskazówki montażowe

- Armatura musi być zamontowana, przepłukana i wypróbowana według obowiązujących norm!
- Uwaga! * Przy urządzeniach 5-litrowych wydajność mieszacza nie może przekraczać 5 l/min. W razie potrzeby wyregulować dopływ wody przy zaworku kątowym.

Dane techniczne

Ciśnienie robocze:	maks. 1 MPa
Zalecane ciśnienie robocze: (1 MPa = 10 bary = 147 PSI)	0,1 - 0,5MPa
Temperatura wody gorącej:	maks. 80 °C
Zalecana temperatura wody gorącej:	65 °C
Wydajność przepływu:	maks. 5 l/min

Opis symbolu



Nie stosować silikonów zawierających kwas octowy!



Konserwacja (patrz strona 36)

- Działanie zabezpieczeń przed przepływem zwrotnym, zgodnie z normą DIN EN 1717 i miejscowymi przepisami, musi być kontrolowane (DIN 1988, raz w roku).
- Przy wymianie kształtownika przepływu należy użyć takiego kształtownika przepływu, którego użycie jest autoryzowane dla danego typu armatury.



Wymiary (patrz strona 33)



Części serwisowe (patrz strona 35)



Obsługa (patrz strona 34)

Przy podgrzaniu zbiornika wody przy wylocie kapie woda.



Czyszczenie

Zalecenie dotyczące pielęgnacji, patrz dołączona broszura.



Znak jakości (patrz strona 32)

Usterka

Przyczyna

Pomoc

Mała ilość wody

- Kształtownik przepływu zakamieniony, zabrudzony

- Wyczyścić lub wymienić kształtownik przepływu

- Zabrudzone sitko w zaworkach kątowych.

- Oczyszczyć / wymienić sitko

Uchwyt armatury pracuje z wysiłkiem

- Uszkodzony wkład, zakamieniony

- Wymiana wkładu

Armatura cieknie zawsze przy wyłączonym podgrzewaczu wody

- Uszkodzony wkład

- Wymiana wkładu

Wyciek wody w obszarze wylewki

- Uszkodzony o-ring

- Wymienić o-ring

Wyciek wody przy mocowaniu od dołu

- Nieszczelne dno przejściówki

- Sprawdzić dno przejściówki, w razie potrzeby wymienić

- Uszkodzony o-ring przy węź przyłączeniowym

- Wymienić o-ring

Wyciek wody pod rączką natrysku

- Uszkodzony wkład

- Wymiana wkładu





Bezpečnostní pokyny

-  Pro zabránění řezným zraněním a pohmožděninám je nutné při montáži nosit rukavice.

Pokyny k montáži

- Armatura se musí montovat, proplachovat a testovat podle platných norem!
- **Pozor!** * U 5litrových přístrojů nesmí výkon výtoku na mísící baterii překročit 5 l/min. Případně je nutno regulovat přívod vody na rohovém ventilu.

Technické údaje

Provozní tlak:	max. 1 MPa
Doporučený provozní tlak: (1 MPa = 10 bar = 147 PSI)	0,1 – 0,5MPa
Teplota horké vody:	max. 80 °C
Doporučená teplota horké vody:	65 °C
Průtok:	max. 5 l/min

Popis symbolů



Nepoužívat silikon s obsahem kyseliny octové!



Údržba (viz strana 36)

- U zpětných ventilů se musí podle DIN EN 1717 v souladu s národními nebo regionálními předpisy testovat jejich funkčnost (alespoň jednou ročně).
- Je-li nutná výměna tvarovače proudu, pak se musí použít tvarovač, který je pro tuto armaturu povolen.



Rozměry (viz strana 33)



Servisní díly (viz strana 35)



Ovládání (viz strana 34)

Při zahřívání bojleru vystupují na výtoku kapky vody.



Čištění

Doporučení k čištění viz příložená brožura.



zkoušební značka (viz strana 32)

Porucha	Příčina	Odstranění
Málo vody	- tvarovač proudu zanesen vodním kamenem, znečištěn - Znečištěný lapač nečistot v rohových ventilech.	- vyčistit, popř. vyměnit tvarovač proudu - vyčistit / vyměnit lapač nečistot
Armatura jde ztěžka	- Kartuše je vadná, zanesená vodním kamenem	- Kartuši vyměnit
z armatury odkapává stále voda i když je ohřívač vody vypnut	- Kartuše je vadná	- Kartuši vyměnit
výstup vody v rozsahu otočného výtoku	- O-kroužek je defektní	- vyměnit O-kroužek
výstup vody na upevňovacím násadci	- Spodní část adaptéru netěsná - O-kroužek na připojovací hadici je defektní	- Zkontrolujte spodní část adaptéru a případně vyměňte - vyměnit O-kroužek
výstup vody pod rukojeť	- Kartuše je vadná	- Kartuši vyměnit



Montáž viz strana 31



Bezpečnostné pokyny

- ⚠ Pri montáži musíte nosiť rukavice, aby ste predišli pomliaždeninám a rezným poraneniam.

Pokyny pre montáž

- Batéria sa musí montovať, preplachovať a testovať podľa platných noriem!
- Pozor! * U 5 l ohrievačov vody nesmie prietok batérie prekročiť 5l/min. Prípadne nastavte prívod vody pomocou uzatváracieho ventilu.

Technické údaje

Prevádzkový tlak:	max. 1 MPa
Doporučený prevádzkový tlak: (1 MPa = 10 bar = 147 PSI)	0,1 - 0,5MPa
Teplota teplej vody:	max. 80 °C
Doporučená teplota teplej vody:	65 °C
Prietok:	max. 5 l/min

Popis symbolov



Nepoužívať silikón s obsahom kyseliny octovej!



Údržba (viď strana 36)

- Pri spätných ventiloch sa musí podľa DIN EN 1717 v súlade s národnými alebo regionálnymi predpismi testovať ich funkčnosť (aspoň raz ročne).
- Pri výmene tvarovača prúdu sa musí použiť tvarovač prípustný pre túto batériu.



Rozmery (viď strana 33)



Servisné diely (viď strana 35)



Obsluha (viď strana 34)

Pri ohreve nádrže na vodu kvapká z odpadu voda.



Čištění

Odporúčanie o čistení nájdete v priloženej brožúre.



Osvedčenie o skúške (viď strana 32)

Porucha	Príčina	Pomoc
Málo vody	- Tvarovač prúdu znečistený vodným kameňom - Filter v rohových ventiloch znečistený	- Vyčistiť resp. vymeniť tvarovač prúdu - Vyčistiť alebo vymeniť filter
Armatúra "chodí" ťažko	- Kartúša je poškodená, vápenaté usadeniny	- Vymeniť kartúšu
Batéria neustále kvapká pri vypnutom zariadení na prípravu vody	- Kartúša je poškodená	- Vymeniť kartúšu
Uhajanje vode ob vrtlivem izlivu	- Chybný O krúžok	- Vymeniť O krúžok
Uhajanje vode ob pritrídilnem nastavku	- Spodok adaptéra je netesný - Chybný O krúžok na pripojovacej hadici	- Skontrolovať spodok adaptéra, v prípade potreby vymeniť - Vymeniť O krúžok
Výstup vody za držiakom	- Kartúša je poškodená	- Vymeniť kartúšu





安全技巧

△ 装配时为避免挤压和切割受伤，必须戴上手套。

安装提示

- 必须按照现行的规定安装，冲洗和测试产品！
- 注意！* 对于5升的热水器，龙头处的流速不得超过5升/分钟。
- 这种情况下，必须在隔离阀降低流速。

技术参数

工作压强: 最大 1 MPa
 推荐工作压强: 0,1 0,5MPa
 (1 MPa = 10 bar = 147 PSI)
 热水温度: 最大 80° C
 推荐热水温度: 65° C
 流速: 最大 5 升/分钟



保养 (参见第36页)

- 单向阀必须在符合国家或当地的法律的情况下按照DIN EN 1717定期检查（至少一年一次）。
- 更换喷雾形成器时，必须使用针对此类型龙头制造的形成器。



大小 (参见第 33 页)



备用零件 (参见第35页)



操作 (参见第 34 页)

加热贮水箱时，水嘴滴水。

符号说明



请勿使用含有乙酸的硅！



清洗

清洁建议参见附入的小册子。



检验标记 (参见第32页)

问题	原因	补救
龙头出水量小	-花洒结垢，脏污 -隔离阀 的过滤网脏污	-清洁花洒，视需要更换 -清洁过滤网/更换过滤网
龙头不灵活	-滤筒损坏，结垢	-更换滤筒
热水器关闭后，龙头持续滴水	-滤筒损坏	-更换滤筒
水从龙头出水嘴流出	-O形环损坏	-更换O形环
水从螺纹底座中流出	-转接器底面不密封 -连接软管的O形环损坏	-检查转接器底面，必要时进行更换 -更换O形环
水从把手下面流出	-滤筒损坏	-更换滤筒





Указания по технике безопасности

- ⚠ Во время монтажа следует надеть перчатки во избежание прищемления и порезов.

Указания по монтажу

- Смеситель должен быть смонтирован по действующим нормам и в соответствии с настоящей инструкцией, проверен на герметичность и безупречность работы
- **ВНИМАНИЕ!** * Для 5-литровых приборов производительность выхода на смесителе не должна превышать 5 л/мин. При необходимости отрегулируйте подачу воды на угловом вентиле

Технические данные

Рабочее давление:	не более. 1 МПа
Рекомендуемое рабочее давление: (1 МПа = 10 bar = 147 PSI)	0,1 – 0,5МПа
Температура горячей воды:	не более. 80 °С
Рекомендуемая темп. гор. воды:	65 °С
Пропускная способность:	не более. 5 л/мин

Описание символов



Не применяйте силикон, содержащий уксусную кислоту.



Техническое обслуживание (см. стр. 36)

- Защита обратного тока должна регулярно проверяться (минимум один раз в год) по стандарту DIN EN 1717 или в соответствии с национальными или региональными нормативами
- При замене формирователя струи необходимо использовать формирователь струи, предназначенный для этой арматуры.

Размеры (см. стр. 33)



Комплект (см. стр. 35)



Эксплуатация (см. стр. 34)



При подогреве водяного резервуара из выхода капает вода.



Очистка

Рекомендации по очистке см. в прилагаемой брошюре.



Знак технического контроля (см. стр. 32)

Неисправность	Причина	Устранение неисправности
недостаточный давление (если устан напор воды)	- Формирователь струи имеет известковые отложения/загрязнен - Грязеулавливающая сетка в угловых вентилях загрязнена.	- Очистите формирователь струи, по мере необходимости замените - Очистите / замените грязеулавливающее сито
Арматура работает с усилием	- Картридж неисправен, засорение накипью	- Замените картридж
Из арматуры при подключенном водонагревателе постоянно капает вода	- Картридж неисправен	- Замените картридж
Выход воды в области поворотного выхода	- Уплотнительное кольцо круглого сечения неисправно	- Замените уплотнительное кольцо круглого сечения
Выход воды у основания крепления	- Основание переходника негерметично	- Проверьте основание переходника, при необходимости замените
	- Уплотнительное кольцо круглого сечения на соединительном шланге неисправно	- Замените уплотнительное кольцо круглого сечения
Выход воды под ручкой	- Картридж неисправен	- Замените картридж





Biztonsági utasítások

-  A szerelésnél a zúzódások és vágási sérülések elkerülése érdekében kesztyűt kell viselni.

Szerelési utasítások

- A csaptelepet az érvényben lévő előírásoknak megfelelően kell felszerelni, átöblíteni és ellenőrizni!
- Figyelem!* Az 5 literes készülékekénél a keverő kifolyóteljesítménye nem haladhatja meg az 5 l/perc értéket. Adott esetben szabályozzuk a sarokszelepnél a vízbefolyást.

Műszaki adatok

Üzemi nyomás:	max. 1 MPa
Ajánlott üzemi nyomás: (1 MPa = 10 bar = 147 PSI)	0,1 – 0,5MPa
Forróvíz hőmérséklet:	max. 80 °C
Forróvíz javasolt hőmérséklete:	65 °C
Átfolyási teljesítmény :	max. 5 l/perc

Szimbólumok leírása



Ne használjon ecetsavtartalmú szilikon!



Karbantartás (lásd a 36. oldalon)

- A visszafolyásgátlók működése a DIN EN 1717 szabványnak megfelelően, a nemzeti vagy területi rendelkezésekkel összhangban, évente egyszer ellenőrizendő!
- Ha kicseréli a sugárformázót, akkor ehhez a csaptelephez jóváhagyott sugárformázót kell használni.



Méretet (lásd a 33. oldalon)



Tartozékok (lásd a 35. oldalon)



Használat (lásd a 34. oldalon)

A víztároló felfűtésekor a kifolyóátl vízcsepegés lép fel.



Tisztítás

Az ajánlott tisztításhoz lásd a mellékelt brosúrát.



Vizsgajel (lásd a 32. oldalon)

Hiba	Ok	Megoldás
Kevés víz	- Sugárformázó elvízkövesedett, elszennyeződött	- Sugárformázó tisztítása, adott esetben cseréje
	- A sarokszelepekben lévő szennyfógo szűrő elszennyeződött.	- Szennyfógo szűrő tisztítása / cseréje
Nehezen nyitható a csap.	- A kerámiabetét meghibásodott, elvízkövesedett.	- A kerámiabetétet ki kell cserélni.
A csaptelep kikapcsolt vízkészítőnél állandóan csepeg	- A kerámiabetét meghibásodott.	- A kerámiabetétet ki kell cserélni.
Vízkilépés a billenthető kifolyó területén	- Tömítőgyűrű meghibásodott	- Tömítőgyűrű kicserélése
Vízkilépés a rögzítőrúdon	- Az adapter alja szivárog	- Ellenőrizze az adapter alját, szükség esetén cserélje ki
	- Csatlakozótömlő tömítőgyűrűje meghibásodott	- Tömítőgyűrű kicserélése
Vízkilépés a fogantyú alatt	- A kerámiabetét meghibásodott.	- A kerámiabetétet ki kell cserélni.



Szerelés lásd a 31. oldalon



Turvallisuusohjeet

-  Asennuksessa on käytettävä käsineitä puristumien ja viiltojen aiheuttamien tapaturmien estämiseksi.

Asennusohjeet

- Kaluste on asennettava, huuhdeltava ja tarkastettava voimassa olevien määräysten mukaisesti!
- Huomio! * Viiden litran laitteilla sekoittajasta ulos tulevan veden määrä ei saa ylittää 5 litraa minuutissa. Rajoita tarvittaessa veden tuloa kulmaventtiilillä.

Tekniset tiedot

Käyttöpain:	maks. 1 MPa
Suosittelut käyttöpain:	0,1 – 0,5MPa
(1 MPa = 10 bar = 147 PSI)	
Kuuman veden lämpötila:	maks. 80 °C
Kuuman veden suosituslämpötila:	65 °C
Läpivirtausmäärä:	maks. 5 l/min

Merkin kuvaus



Älä käytä etikkahappopitoista silikoniala!



Huolto (katso sivu 36)

- Vastaventtiilien toiminta on tarkastettava säännöllisesti paikallisten ja kansallisten määräysten mukaisesti (DIN 1988, kerran vuodessa).
- Jos vesisuikun muotoilija vaihdetaan, on käytettävä tälle kalusteelle hyväksyttyä muotoilijaa.



Mitat (katso sivu 33)



Varaosat (katso sivu 35)



Käyttö (katso sivu 34)

Vedenvaraajaa kuumennettaessa juoksuputkesta tippuu vettä.



Puhdistus

Katso puhdistussuositus mukana olevasta esitteestä.



Koestusmerkki (katso sivu 32)

Häiriö

Vähän vettä

Syy

- Suihkunmuotoilija kalkkiintunut, likaantunut
- Kulmaventtiilien likasihdit likaantuneet

Toimenpide

- Puhdista suihkunmuotoilija, vaihda tarvittaessa
- Puhdista / vaihda likasihti

Hana on raskaskäyttöinen

- Patruuna rikki, kalkkikerrostumia

- Vaihda patruuna

Hanasta tippuu jatkuvasti vettä vedenkäsittelylaitteen ollessa kytkettynä pois päältä

- Patruuna rikki

- Vaihda patruuna

Vettä valuu kääntyvän juoksuputken juuresta

- O-rengas on rikki

- Vaihda O-rengas

Vettä valuu kiinnityskauluksesta

- Sovittimen pohja epätiivis

- Sovittimen pohja tarkastetaan, vaihdetaan tarvittaessa.

- Liitosletkun O-rengas on rikki

- Vaihda O-rengas

Vettä valuu kahvan alta

- Patruuna rikki

- Vaihda patruuna





Säkerhetsanvisningar

-  Handskar ska bäras under monteringsarbetet så att man kan undvika kläm- och skärskadorgen werden.

Monteringsanvisningar

- Blandaren måste installeras, genomspolas och testas enligt gällande föreskrifter.
- OBS!* Utlödeseffekten i blandaren får inte överstiga 5l/minut hos 5 liters behållare. Ställ in vattenflödet vid hörnventilen om detta behövs.

Tekniska data

Driftstryck:	max. 1 MPa
Rek. driftstryck: (1 MPa = 10 bar = 147 PSI)	0,1 - 0,5MPa
Varmvattentemperatur:	max. 80°C
Rek. varmvattentemp.:	65°C
Genomströmningmängd:	max. 5 l/min

Simbolio aprašymas



Använd inte silikon som innehåller ättiksyra!



Skötsel (se sidan 36)

- Backventilens funktion måste kontrolleras regelbundet enligt nationella eller regionala bestämmelser (DIN 1988 en gång per år) i enlighet med DIN EN 1717.
- Om strålkanselheten byts måste en enhet som passar till blandaren användas.



Måtten (se sidan 33)



Reservdelar (se sidan 35)



Hantering (se sidan 34)

Vatten droppar från den utdragbara blandaren när vattenberedaren värms upp.



Rengöring

Se den medföljande broschyren för rengöringsrekommendation



Testsigill (se sidan 32)

Störning

Orsak

Åtgärd

För lite vatten

- Strålkkanaler är täckta av kalk, smutsiga

- Rengör strålkkanaler, byt ut enhet om nödvändigt

- Smutsfilter i hörnventilerna smutsigt.

- Rengör / byt ut smutsfilter

Blandare är trög

- Patron defekt, förkalkad

- Byt ut patron

Blandaren droppar ständigt när vattnet är avstängt

- Patron defekt

- Byt ut patron

Vatten kommer ut vid den svängbara blandaren

- O-ring defekt

- Byt ut O-ring

Vatten kommer ut vid monteringsstaget

- Adapterbotten otät

- Undersök adapterbotten, byt ut vid behov

- O-ring på anslutningsslang defekt

- Byt ut O-ring

Vatten kommer ut under greppet

- Patron defekt

- Byt ut patron





Saugumo technikos nurodymai

 Apsaugai nuo užspaudimo ir įsijovimo montavimo metu mūvėkite pirštines.

Montavimo instrukcija

- Maišytuvus privalo būti montuojamas, išleidžiamas ir patikrinamas pagal galiojančias normas!
- Dėmesio!* Jei vandens šildytuvų talpa 5 litrai, maišytuvo vandens tekėjimo norma neturėtų viršyti 5 l/mažiausiai. Jei norma viršijama, reikia sumažinti kampinių vožtuvų srauto pralaidumą.

Techniniai duomenys

Darbinis slėgis: ne daugiau kaip 1 MPa
 Rekomenduojamas slėgis: 0,1 – 0,5MPa
 (1 MPa = 10 barų = 147 PSI)
 Karšto vandens temperatūra: ne daugiau kaip 80 °C
 Rekomenduojama karšto vandens temperatūra: 65 °C
 Vandens pralaidumas: ne daugiau kaip 5 l/min

Simbolio aprašymas



Nenaudokite silikono, kurio sudėtyje yra acto rūgšties!



Techninis aptarnavimas (žr. psl. 36)

- Atbulinio vožtuvo apsauga privalo būti tikrinama reguliariai (mažiausiai kartą per metus pagal DIN 1988) pagal DIN EN 1717 arba pagal galiojančias nacionalines arba regionines normas.
- Keičiant čiaupą būtina naudokite šitam maišytuvui pritaikytą čiaupą.



Išmatavimai (žr. psl. 33)



Atsarginės dalys (žr. psl. 35)



Eksplotacija (žr. psl. 34)

Kaitinant vandens talpą čiaupas lašės.



Valymas

Valymo rekomendacijas žr. pridedamoje brošiūroje.



Bandyimo pažyma (žr. psl. 32)

Gedimas

Priežastis

Priemonė

Per maža srovė

- Čiaupas užkalkėjęs arba jame yra šiukšlių

- Čiaupą išvalyti arba pakeisti

- Užsikimšęs kampinio ventilio filtras

- Išvalykite arba pakeiskite filtrą.

Sunkiai sukiojama rankenėlė

- Kasetė pažeista, užkalkėjusi

- Pakeisti kasetę

Uždarius, maišytuvus nuolat praleidžia vandenį

- Kasetė pažeista

- Pakeisti kasetę

Prateka vanduo po čiaupu

- tarpinė pažeista

- tarpinę pakeisti

Prateka vanduo per tvirtinimo kotą

- Nesandarus adapterio pagrindas

- Patikrinkite adapterio pagrindą ir, jeigu reikia, pakeiskite

- Pajungimo žarnos tarpinė pažeista

- tarpinę pakeisti

Prateka vanduo po rankenėle

- Kasetė pažeista

- Pakeisti kasetę





Sigurnosne upute

 Prilikom montaže se radi sprječavanja prignječenja i posjekotina moraju nositi rukavice.

Upute za montažu

- Cijevi moraju biti postavljene, isprane i testirane prema važećim normama!
- Pažnja! * Kod 5 -litarskih uređaja protok u mješalici ne smije prijeći 5 litara/min. Regulirajte dotok vode na kutnom ventilu

Tehnički podaci

Najveći dopušteni tlak:

tlak 1 MPa

Preporučeni tlak:

0,1 - 0,5MPa

(1 MPa = 10 bar = 147 PSI)

Temperatura vruće vode:

tlak 80°C

Preporučena temperatura vruće vode:

65°C

Protok vode:

tlak 5 l/min



Održavanje (pogledaj stranicu 36)

- Ispravnost nepovratnog ventila mora se redovito provjeravati prema standardu DIN EN 1717 i u skladu sa važećim propisima (najmanje jednom godišnje).
- Ako želite izmijeniti mjenjač mlaza, potrebno je koristiti mjenjač propisan uz ovu armaturu



Mjere (pogledaj stranicu 33)



Rezervni dijelovi (pogledaj stranicu 35)



Upotreba (pogledaj stranicu 34)

Pri zagrijavanju bojlera na izlazu slavine pojavit će se kapljice vode

Opis simbola



Nemojte koristiti silikon koji sadrži octenu kiselinu!



Čišćenje

Upute za čišćenje nalaze se u priloženoj brošuri.



Oznaka testiranja (pogledaj stranicu 32)

Greška

Uzrok

Otklanjanje

Nedovoljno vode

- Mijenač mlaza je prljav ili začepljen - Očistite ili zamijenite mjenjač mlaza naslagama kamenca

- Očistite filtar za skupljanje nečistoće u kutnim ventilima - Očistite/zamijenite filtar za skupljanje nečistoće

Ručica se zaglavila

- Neispravan uložak Taloženje kamenca - Zamijenite uložak

Slavina kaplje i kad je grijač vode zatvoren

- Neispravan uložak - Zamijenite uložak

Voda izlazi u području rotirajućih dijelova slavine

- O-prsten je neispravan - Zamijenite O-prsten

Voda izlazi na dijelu gdje je slavina učvršćena

- Dno adaptera ne brtvi - Provjerite i po potrebi zamijenite dno adaptera

- O-prsteni priključnih crijeva su neispravni - Zamijenite O-prsten

Voda curi ispod ručice

- Neispravan uložak - Zamijenite uložak



Sastavljanje pogledaj stranicu 31



Güvenlik uyarıları

- ⚠ Montaj esnasında ezilme ve kesilme gibi yaralanmaları önlemek için eldiven kullanılmalıdır.

Montaj açıklamaları

- Batarya geçerli normlara göre monte edilmeli, yıkanmalı ve kontrol edilmelidir!
- Önemli! * 5 litrelik cihazlarda, maks bataryadaki çıkış gücü 5 l/dk'yı aşmamalıdır. Gerekirse, ara musluktaki su beslemesini ayarlayın.

Teknik bilgiler

İşletme basıncı:

Tavsiye edilen işletme basıncı:

(1 MPa = 10 bar = 147 PSI)

Sıcak su sıcaklığı:

Tavsiye edilen su ısısı:

Debisi :

azami 1 MPa

0,1 - 0,5MPa

azami 80°C

65°C

azami 5 l/dak



Bakım (Bakınız sayfa 36)

- DIN EN 1717 ve ulusal standartlar doğrultusunda Çek valfler düzenli olarak kontrol edilmelidir. (en az yılda bir kez)
- Sprey modül değiştirilirse, bu batarya için izin verilmiş bir spray modül kullanılmalıdır.



Ölçüleri (Bakınız sayfa 33)



Yedek Parçalar (Bakınız sayfa 35)



Kullanımı (Bakınız sayfa 34)

Su deposunun ısınması durumunda, çıkıştan su damlaları akar.

Simge açıklaması



Asetik asit içeren silikon kullanmayın!



Temizleme

Temizlik önerisi için birlikte verilen broşüre bakınız.



Kontrol işareti (Bakınız sayfa 32)

arıza	sebebi	yardım
Az su geliyor	- Sprey modül kireçlenmiş, kirlenmiş - Ara musluktaki filtre kirlenmiş.	- Sprey modülü temizleyin, gerekirse değiştirin - Filtreyi temizleyin / değiştirin
Batarya kullanımı ağırlaşıyor	- Kartuş Bozulmuş ve kireçlenmiş olabilir	- Kartuşu değiştirin
Su hazırlayıcı kapalıyken batarya sürekli olarak su damlatıyor	- Kartuş bozuk olabilir	- Kartuşu değiştirin
Döner çıkış bölgesinden su çıkışı	- O-ring arızalı	- O-ringi değiştirin
Sabitleme kutusundan su çıkışı	- Adaptörün tabanı sızdırıyor - Bağlantı hortumundaki O-ring arızalı	- Adaptörün tabanını kontrol edin, gerekirse değiştirin - O-ringi değiştirin
Kumanda kolunun altından su çıkışı	- Kartuş bozuk olabilir	- Kartuşu değiştirin





Instrucțiuni de siguranță

- ⚠ La montare utilizați mănuși pentru evitarea contuziunilor și tăierii mâinilor.

Instrucțiuni de montare

- Bateria trebuie montată, clătită și verificată conform normelor în vigoare.
- Atenție!* La boilere de apă de 5 litri debitul apei la amestecător nu trebuie să depășească 5 l/min. În caz contrar reglați debitul de apă cu ajutorul ventilelor de colț.

Date tehnice

Presiune de funcționare:	max. 1 MPa
Presiune de funcționare recomandată:	0,1 - 0,5MPa (1 MPa = 10 bar = 147 PSI)
Temperatura apei calde:	max. 80 °C
Temperatura recomandată a apei calde:	65 °C
Debit de apă:	max. 5 l/min

Descrierea simbolurilor



Nu utilizați silikon cu conținut de acid acetic!



Întreținere (vezi pag. 36)

- Supapele de reținere trebuie verificate regulat conform DIN EN 1717 și standardele naționale sau regionale (anual conform DIN 1988).
- Dacă schimbați duza de jet, trebuie să utilizați o duză jet potrivită pentru această baterie.



Dimensiuni (vezi pag. 33)



Piese de schimb (vezi pag. 35)



Utilizare (vezi pag. 34)

La încălzirea rezervorului de apă, apa picură din pipă.



Curățare

Pentru recomandările referitoare la curățare vezi broșura alăturată.



Certificat de testare (vezi pag. 32)

Deranjament	Cauza	Măsuri de remediere
Prea puțină apă	- Depuneri de calcar și impurități pe duza jet. - Sita de impurități din ventilul de colț este murdar	- Curățați sau schimbați duza jet dacă este cazul. - Curățați / schimbați sita de impurități
Bateria se mișcă dificil	- Cartuș defect din cauza depunerilor de calcar	- Schimbați cartușul.
Picură în continuu din baterie când boilerul de apă este oprit.	- Cartuș defect	- Schimbați cartușul.
Scurgere de apă în zona pipei rabatabile.	- Inel O defect	- Schimbați inelul O.
Scurgere de apă la șaftul de fixare.	- Baza adaptorului este neetanșă - Inelul O de la furtunul de racord defect	- Verificați baza adaptorului și schimbați-l dacă este nevoie. - Schimbați inelul O.
Scurgere de apă sub mână.	- Cartuș defect	- Schimbați cartușul.



Montare vezi pag. 31



Υποδειξεις ασφαλείας

- ⚠ Για να αποφύγετε τραυματισμούς κατά τη συναρμολόγηση πρέπει να φοράτε γάντια.

Οδηγίες συναρμολόγησης

- Η κεντρική βάνα πρέπει να τοποθετηθεί, να πλυθεί και να ελεγχθεί με βάση τους ισχύοντες κανόνες υδραυλικής τέχνης!
- Προσοχή! * Σε συσκευές 5 λίτρων, η κατανάλωση νερού της μπαταρίας (μείκτη) δεν επιτρέπεται να υπερβαίνει τα 5 λίτρα ανά λεπτό. Αν χρειαστεί, ρυθμίστε την παροχή νερού στη γωνιακή βαλβίδα.

Τεχνικά Χαρακτηριστικά

Λειτουργία πίεσης:	έως 1 MPa
Συνιστώμενη λειτουργία πίεσης: (1 MPa = 10 bar = 147 PSI)	0,1 - 0,5MPa
Θερμοκρασία ζεστού νερού:	έως 80 °C
Συνιστώμενη θερμοκρασία ζεστού νερού:	65 °C
Κατανάλωση νερού:	έως 5 l/min

Περιγραφή συμβόλων



Μην χρησιμοποιείτε σιλικόνη που περιέχει οξικό οξύ!



Συντήρηση (βλ. σελίδα 36)

- Οι βαλβίδες αντεπιστροφής πρέπει να ελέγχονται τακτικά ως προς τη λειτουργία τους, σύμφωνα με τις οδηγίες DIN EN 1717, σε σχέση με τους ισχύοντες εθνικούς ή τοπικούς κανόνες (το ελάχιστο μια φορά το χρόνο, σύμφωνα με το πρότυπο DIN 1988)
- Εάν γίνει αλλαγή των καναλιών καταιονισμού, πρέπει να χρησιμοποιηθεί ένας επιτρεπόμενος για τη συγκεκριμένη βάνα καταιονιστήρας.



Διαστάσεις (βλ. σελίδα 33)



Ανταλλακτικά (βλ. σελίδα 35)



Χειρισμός (βλ. σελίδα 34)

Σε περίπτωση θέρμανσης της δεξαμενής νερού, στο στόμιο εκροής εμφανίζονται σταγονίδια νερού.



Καθαρισμός

Για οδηγίες καθαρισμού βλέπε συνημμένο ενημερωτικό φυλλάδιο.



Σήμα ελέγχου (βλ. σελίδα 32)

Βλάβη

Ανεπαρκές νερό

Αιτία

- Ο καταιονιστήρας (ντους) φέρει άλατα και βρωμιές
- Το φίλτρο συλλογής ακαθαρσιών είναι βρώμικο στις γωνιακές βαλβίδες.

Διόρθωση

- Καθαρίστε και, εάν χρειαστεί, αλλάξτε τον καταιονιστήρα (ντους)
- Καθαρίστε / αλλάξτε το φίλτρο συλλογής ακαθαρσιών

Σκληρή μπαταρία (μείκτης)

- Ελαττωματικό φυσιγγίο, άλατα

- Αλλαγή φυσιγγίου

Η μπαταρία στάζει διαρκώς σε απενεργοποιημένο θερμοσίφωνα

- Ελαττωματικό φυσιγγίο

- Αλλαγή φυσιγγίου

Διαρροή νερού στην περιοχή του περιστρεφόμενου ρουζουνιού.

- Ελαττωματικός στρογγυλός δακτύλιος

- Αλλάξτε το στρογγυλό δακτύλιο

Διαρροή νερού στον άξονα στερέωσης

- Μη στεγανό δάπεδο αντάππορα
- Ο στρογγυλός δακτύλιος στο σωλήνα σύνδεσης είναι ελαττωματικός

- Ελέγξτε το δάπεδο του αντάππορα και, εάν χρειάζεται, αντικαταστήστε το

Διαρροή νερού κάτω από τη λαβή

- cartucho dañado

- Αλλαγή φυσιγγίου





Varnostna opozorila

-  Pri montaži je treba nositi rokavice, da se prepreči poškodbe zaradi zmečkanja ali urezov.

Navodila za montažo

- Armature je potrebno montirati, sprati in testirati v skladu z veljavnimi normami!
- Pozor! * Pri 5-litrskih aparatih zmogljivost izliva na mešalni bateriji ne sme presegati 5 l/min. Če je potrebno, se na kotnem ventilu nastavi dotok vode.

Tehnični podatki

Delovni tlak:	maks. 1 MPa
Priporočeni delovni tlak: (1 MPa = 10 bar = 147 PSI)	0,1 – 0,5MPa
Temperatura tople vode:	maks. 80 °C
Priporočena temperatura tople vode:	65 °C
Pretok vode:	maks. 5 l/min

Opis simbola



Ne smete uporabiti silikona, ki vsebuje ocetno kislino!



Vzdrževanje (glejte stran 36)

- Delovanje protipovratnega ventila je potrebno v skladu z DIN EN 1717 in skladno z državnimi in regionalnimi določili (DIN 1988 enkrat letno) redno testirati.
- Če zamenjate oblikovalnik curkov, morate uporabiti takega, ki je primeren za ta tip armature.



Mere (glejte stran 33)



Rezervni deli (glejte stran 35)



Upravljanje (glejte stran 34)

Pri segrevanju rezervoarja za vodo na izlivu kaplja.



Čiščenje

Priporočilo za čiščenje glejte v priloženi brošuri.



Preskusni znak (glejte stran 32)

Napaka	Vzrok	Pomoč
Malo vode	- Oblikovalnik curka je poapnen, umazan - Lovilnik umazanije v kotnih ventilih je umazan.	- Očistite oz. po potrebi zamenjajte oblikovalnik curka - Lovilnik umazanije očistite oz. zamenjajte
Težko premikanje armature	- Pokvarjen vložek, poapneno	- Zamenjajte vložek
Iz armature stalno kaplja ob izklopljenem grelniku	- Pokvarjen vložek	- Zamenjajte vložek
Uhajanje vode ob vrtiljvem izlivu	- Obročna tesnilo je pokvarjeno	- Zamenjajte obročna tesnilo
Uhajanje vode ob pritrdilnem nastavku	- netesno dno adapterja - Obročna tesnila priključnih gibkih cevi so pokvarjena	- Preverite dno adapterja, po potrebi ga zamenjajte - Zamenjajte obročna tesnilo
Uhajanje vode pod ročko	- Pokvarjen vložek	- Zamenjajte vložek





Ohutusjuhised

- △ Kandke paigaldamisel muljumis- ja löikevigastuste vältimiseks kindaid.

Paigaldamisjuhised

- Segisti paigaldamine, loputamine ja kontroll peab toimuma vastavalt kehtivatele normidele!
- Tähelepanu!* 5-liitriste veeboilerite puhul ei või segisti väljavool ületada 5 l/min. Vajadusel piirake nurgaklapist vee juurdevoolu.

Tehnilised andmed

Töörõhk

Soovitav töörõhk:

(1 MPa = 10 baari = 147 PSI)

Kuuma vee temperatuur:

Soovitav kuumu vee temperatuur:

Läbivool:

maks. 1 MPa

0,1 – 0,5MPa

maks. 80°C

65°C

maks. 5 l/min



Hooldus (vt lk 36)

- Tagasilöögiklappide toimimist tuleb kooskõlas riiklike ja regionaalsete määrustega regulaarselt kontrollida vastavalt standardile DIN EN 1717 (DIN 1988 - kord aastas).
- Joavormija vahetamise korral tuleb kasutada vaid selle segisti jaoks lubatud vormijat.



Mõõtude (vt lk 33)



Varuosad (vt lk 35)



Kasutamine (vt lk 34)

Veemahuti kuumutamisel hakkab väljavool tilkuma.

Sümbolite kirjeldus



Ärge kasutage äädikhapet sisaldavat silikooni!



Puhastamine

Puhastussoovitusi vt kaasasolevast brošüürist.



Kontrollsertifikaat (vt lk 32)

Rike	Põhjus	Lahendus
Vähe vett	- Veepihusti lubjastunud, must - Nurkventiilide mustusesõel must.	- Puhastage veepihusti, vajadusel vahetage välja - Mustusesõel puhastada / välja vahetada
Segisti käib raskelt	- Tööelement on katkine, lubjastunud	- Vahetage tööelement
Segisti tilgub pidevalt, kui veeboiler on välja lülitatud	- Tööelement on katkine	- Vahetage tööelement
Veeleke pööratavas jooksutorus	- O-rõngastihend on katki	- Zamenjajte obročno tesnilo
Veeleke kinnituse juures	- Adapteri põhi pole tihe - Ühendusvoolikute O-rõngastihendid katki	- Kontrollige adapteri põhja, vahetage vajadusel - Vahetage O-rõngastihend
Veeleke käepideme all	- Tööelement on katkine	- Vahetage tööelement



Paigaldamine vt lk 31



Drošības norādes

 Montāžas laikā, lai izvairītos no saspiedumiem un iegriezumiem, nepieciešams nēsāt cimdus.

Norādījumi montāžai

- Armatūra jāuzstāda, jāizskalo un jāpārbauda atbilstoši spēkā esošajām normām!
- Uzmanību! * 5 l ūdens sildītājiem caurplūde jāucējkrānam nedrīkst pārsniegt 5 l/min. Nepieciešamības gadījumā ūdens padevi regulē ar stūra ventili.

Tehniskie dati

Darba spiediens: maks. 1 MPa
 leteicamais darba spiediens: 0,1 – 0,5MPa
 (1 MPa = 10 bar = 147 PSI)
 Karstā ūdens temperatūra: maks. 80 °C
 leteicamā karstā ūdens temperatūra: 65 °C
 Caurteces intensitāte: maks. 5 l/min



Apkope (skat. 36. lpp.)

- Regulāri jāpārbauda pretvārsta funkcija saskaņā ar DIN EN 1717 saistībā ar nacionālajiem vai vietējiem noteikumiem (DIN 1988 vienreiz gadā).
- Ja tiek nomainīts strūklas veidotājs, jāizmanto šim jāucējkrānam paredzēts strūklas veidotājs.



Izmērus (skat. 33. lpp.)



Rezerves daļas (skat. 35. lpp.)



Lietošana (skat. 34. lpp.)

Karsējot ūdens boileri pa snīpi pil ūdens.

Simbolu nozīme



Neizmantoj silikonu, kas satur etiķskābi!



Tīrīšana

Ieteikumus tīrīšanai skatiet pievienotajā brošūrā.



Pārbaudes zīme (skat. 32. lpp.)

Traucējums

Iemesls

Bojājumu novēršana

Maz ūdens

- Strūklas veidotājs ir aizkaļķojies, nefīrs

- Iztīrīt, nepieciešamības gad. nomainīt strūklas veidotāju

- Stūra ventīļos ir nefīrs filtrs.

- Iztīrīt / nomainīt filtru

Jaucējkrāns smagi grozāms

- Bojāta kartuša, aizkaļķojusies

- Nomainīt kartušu

Jaucējkrāns nepārtraukti pil ar izslēgta ūdens sagatavotāja gadījumā

- Bojāta kartuša

- Nomainīt kartušu

Ūdens noplūde grozāmās iztekas rajonā

- Bojāts O-gredzens

- Nomainīt O-gredzenu

Ūdens noplūde pie nostiprinājuma

- Bojāta adaptera pamatne

- Pārbaudīt adaptera pamatni, ja nepieciešams - nomainīt

- Bojāti pieslēguma šļūteņu O-gredzeni

- Nomainīt O-gredzenu

Ūdens noplūde zem roktura

- Bojāta kartuša

- Nomainīt kartušu





Sigurnosne napomene

- ⚠ Prilikom montaže se radi sprečavanja prignječenja i posekotina moraju nositi rukavice.

Instrukcije za montažu

- Armatura mora biti postavljena, isprana i testirana prema važećim normama!
- Pažnja!* Kod 5 -litarskih uređaja protok u mešaču ne sme preći 5 l/min. Regulirajte dotok vode na ugaonom ventilu.

Tehnički podaci

Radni pritisak:	maks. 1 MPa
Preporučeni radni pritisak: (1 MPa = 10 bar = 147 PSI)	0,1 – 0,5MPa
Temperatura vruće vode:	maks. 80 °C
Preporučena temperatura vruće vode:	65 °C
Protok vode:	maks. 5 l/min

Opis simbola



Nemojte koristiti silikon koji sadrži sircetnu kiselinu!



Održavanje (vidi stranu 36)

- Ispravno funkcionisanje nepovratnog ventila se mora redovno proveravati prema standardu DIN EN 1717 i u skladu s važećim nacionalnim ili regionalnim propisima (DIN 1988 jednom godišnje).
- Ako želite zameniti uobličavač mlaza, sme se koristiti samo uobličavač dozvoljen za ovu armaturu.



Mere (vidi stranu 33)



Rezervni delovi (vidi stranu 35)



Rukovanje (vidi stranu 34)

Kada se bojler zagreva, slavina počinje da kaplje.



Čišćenje

Preporuke za čišćenje možete naći u priloženoj brošuri.



Ispitni znak (vidi stranu 32)

Smetnja

Uzrok

Pomoć

Nedovoljno vode	- Uobličavač mlaza je prljav ili začepljen naslagama kamenca	- Očistite ili zamenite uobličavač mlaza
	- Očistite mrežicu za hvatanje prljavštine u ugaonim ventilima	- Očistite / zamenite mrežicu za hvatanje prljavštine
Ručica se zaglavila	- Neispravna kartuša, nataloženi kamenac	- Zamenite kartušu
Slavina kaplje i kad je grejač vode zatvoren	- Neispravna kartuša	- Zamenite kartušu
Voda izlazi u zglobu slavine	- O prsten je neispravan	- Zamenite O prsten
Voda izlazi na delu gde je slavina učvršćena	- Dno adaptera ne zaptiva	- Proverite i po potrebi zamenite dno adaptera
	- O prstenovi priključnih creva su neispravni	- Zamenite O prsten
Voda curi ispod ručice	- Neispravna kartuša	- Zamenite kartušu





Sikkerhetshenvisninger

- ⚠ Bruk hansker under montasjen for å unngå klem- og kuttskader.

Montagehenvisninger

- Armaturen skal monteres iht. gyldige standarder. De skal spyles og sjekkes!
- Obs!* Ved 5 liters apparater skal utløpsytelsen på blandebatteriet ikke overstige 5 l/min.

Tekniske data

Driftstrykk	maks. 1 MPa
Anbefalt driftstrykk: (1 MPa = 10 bar = 147 PSI)	0,1 - 0,5MPa
Varmtvannstemperatur	maks. 80 °C
Anbefalt temperatur for varmt vann	65 °C
Gjennomstrømningsytelse:	maks. 5 l/min

Symbolbeskrivelse



Ikke bruk silikon som inneholder eddiksyre!



Vedlikehold (se side 36)

- Funksjonen til returløpssperren skal iht. DIN EN 1717 og i samsvar med de nasjonale og lokale forskrifter sjekkes regelmessig (DIN 1988 en gang i året).
- Når stråleformer byttes, skal den erstattes med en stråleformer som er godkjent for denne armaturen.



Mål (se side 33)



Servicedeler (se side 35)



Betjening (se side 34)

Ved oppvarming av vannbeholdningen drypper det vann fra utløpet.



Rengjøring

Se vedlagt brosjyre for rengjøringsanbefalinger.



Prøvermerke (se side 32)

Feil	Årsak	Feilrettelse
Lite vann	- Stråleformer er forkalket, skitten	- Stråleformer rengjøres og byttes hvis nødvendig
	- Smussfangersil i hjørneventiler er skitten	- Smussfangersil rengjøres / byttes
Armatur ikke lett bevegelig	- Kartusj defekt, forkalkning	- Kartusj byttes
Armatur drypper stadig ved utkoblet vannbehandler	- Kartusj defekt	- Kartusj byttes
Vannlekkasje i området for svingutløpet	- O-ring defekt	- O-ring byttes
Vannlekkasje på festeskaft	- Adapterbunn utett	- Sjekk adapterbunn, skift ut hvis nødvendig.
	- O-ring på tilkoblingsslangen defekt	- O-ring byttes
Vannlekkasje under grepet	- Kartusj defekt	- Kartusj byttes



Montasje se side 31



Указания за безопасност

- ⚠ При монтажа трябва да се носят ръкавици, за да се избегнат наранявания поради притискане или порязване.

Указания за монтаж

- Арматурата трябва да се монтира, промие и провери в съответствие с валидните норми!
- Внимание!* При 5 литрови уреди мощността на изпускане от смесителя не бива да надвишава 5 л/мин. Ако е необходимо, регулирайте подаването на вода от ъгловия клапан.

Технически данни

Работно налягане:	макс. 1 МПа
Препоръчително работно налягане: (1 МПа = 10 bar = 147 PSI)	0,1 – 0,5 МПа
Температура на горещата вода:	макс. 80 °С
Препоръчителна температура на горещата вода:	65 °С
Мощност на потока:	макс. 5 л/мин

Описание на символите



Не използвайте силикон, съдържащ оцетна киселина!



Поддръжка (вижте стр. 36)

- Съгласно DIN EN 1717 редовно трябва да се проверява функционирането на приспособленията за предотвратяване на обратния поток в съответствие с националните или регионални изисквания (DIN 1988 веднъж годишно).
- Ако се сменя приспособлението за оформяне на струята, трябва да се използва приспособление, което е разрешено за тази арматура.



Размери (вижте стр. 33)



Сервизни части (вижте стр. 35)



Обслужване (вижте стр. 34)

При нагряване на резервоара за вода от изходящия накрайник капе вода.



Почистване

Вижте препоръките при почистване от приложената брошура.



Контролен знак (вижте стр. 32)

Неизправност

Причина

Помощ

Малко вода

- Приспособлението за оформяне на струята е покрито с варовик, замърсен

- Почистете респ. сменете приспособлението за оформяне на струята

- Цедката за улавяне на замърсяванията в ъгловите клапани е замърсена.

- Почистете / сменете цедката за улавяне на замърсяванията

Трудно подвижна арматура

- Дефектна гилза, покрита с варовик

- Сменете гилзата

Арматурата капе постоянно при изключен водоподготвитель

- Дефектна гилза

- Сменете гилзата

Избиване на вода в областта на завъртащия се изходящ накрайник

- Дефектен О-образен пръстен

- Смяна на О-образен пръстен

Избиване на вода от закрепващата шийка

- Дъното на адаптера не е уплътнено

- Проверете дъното на адаптера, ако е необходимо го сменете

- Дефектен О-образен пръстен на свързващия маркуч

- Смяна на О-образен пръстен

Избиване на вода под ръкохватката

- Дефектна гилза

- Сменете гилзата



Монтаж вижте стр. 31



Udhëzime sigurie

 Për të evituar lëndimet e pickimeve ose të prerjeve gjatë procesit të montimit duhet që të vishni doreza.

Udhëzime për montimin

- Armatura duhet montuar, shpërlarë dhe kontrolluar në bazë të normave të vlefshme!
- Kujdes!* Tek pajisjet 5-litërshe kapaciteti i rrjedhjes së rubinetit me ujë të përzier nuk duhet të tejkalojë 5 l/min. Nëse është e nevojshme, atëherë rregulloni furnizimin me ujë në ventilin këndor.

Të dhëna teknike

Presioni gjatë punës	maks. 1 MPa
Presioni i rekomanduar:	0,1 – 0,5MPa
(1 MPa = 10 bar = 147 PSI)	
Temperatura e ujit të ngrohtë	maks. 80 °C
Temperatura e rekomanduar e ujit të ngrohtë:	65 °C
Kapaciteti i rrjedhjes:	maks. 5 l/min

Përshkrimi i simbolit



Mos përdorni silikon që në përbërje ka acid acetik.



Mirëmbajtja (shih faqen 36)

- Penguesit e rrjedhjes në drejtim të kundërt duhen kontrolluar rregullisht në bazë të normave DIN EN 1717 konform normave nacionale dhe regjionale (DIN 1988 një herë në vit).
- Nëse ndërrohet formuesi i currilit, atëherë duhet zgjedhur një formues currili i lejuar për këtë armaturë.



Përmasat (shih faqen 33)



Pjesë ndërrimi (shih faqen 35)



Përdorimi (shih faqen 34)

Gjatë ngrohjes së mbledhësit të ujit pikon ujë në dalje të rubinetit.



Pastrimi

Për rekomandime mbi pastrimin shikoni broshurën bashkëngjitur.



Shenja e kontrollit (shih faqen 32)

Dentim

Pak ujë

Shkaku

- Rrezatuesi me kalk, me papasterti
- Sita për mbledhjen e papastërtive në ventilat këndorë është e ndotur.

Ndihme

- Pastroni ose kembeni rrezatuesin
- Pastroni / këmbeni sitën

Armatura punon rende

- Kartusha me defekt, me kalk

- Kembeni kartushen

Armatura pikon vazhdimisht edhe kur pergatitesi i ujit eshte i fikur

- Kartusha me defekt

- Kembeni kartushen

Derdhje e ujit në zonën e daljes

- Unaza O me defekt

- Kembeni unazen O

Dalje e ujit ne cilindrin fiksues

- Bazamenti i përshtatësit nuk është hermetik

- Kontrolloni bazamentin e përshtatësit, nëse është e nevojshme ndërrojeni

- Unaza O tek tubi lidhes me defekt

- Kembeni unazen O

Dalje e ujit poshtë dorezës

- Kartusha me defekt

- Kembeni kartushen





الصيانة (راجع صفحة 36)



• يجب فحص صمام عدم الرجوع بصفة منتظمة حسب المواصفة DIN EN 1717 وذلك طبقاً للوائح الوطنية أو الإقليمية (مرة واحد سنوياً طبقاً للمواصفة DIN 1988).

• عند تغيير طرف الرشاش، لا بد من استخدام طرف بديل مصنوع خصيصاً لهذا النوع من الخلطات.

أبعاد (راجع صفحة 33)



قطع الغيار (راجع صفحة 35)



التشغيل (راجع صفحة 34)

• عند تسخين خزان التخزين، سوف يقطر الصنبور.

التنظيف



• للاطلاع على النصائح الخاصة بالتنظيف انظر الكتيب المرفق.

شهادة اختبار (راجع صفحة 32)



تنبيهات الأمان



⚠ يجب ارتداء قفازات الليد أثناء التركيب لتجنب حدوث أضرار الإنحشار أو الجروح.

تعليمات التركيب

• يجب تركيب الوصلة، وغمرها بالماء واختبارها وفقاً للمعايير السارية!

• تنبيه! * عند استخدام سخانات مياه سعة 5 لتر يجب ألا يتجاوز معدل التدفق 5 ل / دقيقة. وفي هذه الحالة يجب تقليل معدل التدفق عند صمام العزل.

المواصفات الفنية

ضغط التشغيل:
ضغط التشغيل الموصى به:
(1 ميجاباسكال = 10 بار = 147 PSI)
درجة حرارة الماء الساخن:
درجة الحرارة الموصى بها للماء الساخن:
معدل التدفق:
الحد الأقصى 1 ميجاباسكال
0,1 – 0,5 ميجاباسكال
الحد الأقصى 80°C
65°C
الحد الأقصى 5 لتر / الدقيقة

وصف الرمز

هام! لا تستخدم السليكون الذي يحتوي على أحماض!



العلاج والإصلاح	السبب	العطل
- قم بتنظيف موجه التيار أو تغييره إذا لزم الأمر	- موجه التيار متسخ / متراكم عليه الجير	الماء غير كافٍ
- قم بتنظيف / تغيير مرشح الاتساخات	- مرشح الاتساخات في الصمامات الجانبية متسخ	
- قم بتغيير الخرطوشة	- الخرطوشة تالفة، تراكم عليها الجير	الخلاط ثقيل الحركة
- قم بتغيير الخرطوشة	- الخرطوشة تالفة	تساقط قطرات مياه من الخلاط دائماً وهو مغلق من المحبس
- قم بتغيير الحلقة الدائرية	- الحلقة الدائرية تالفة	خروج الماء من منطقة الخروج المتأرجح
- افحص أرضية المهايي، وقم بتغييرها عند اللزوم	- أرضية المهايي بها تسريب	خروج الماء من جزء التثبيت
- قم بتغيير الحلقة الدائرية	- الحلقة الدائرية الخاصة بخرطوم التوصيل تالفة	
- قم بتغيير الخرطوشة	- الخرطوشة تالفة	خروج الماء من تحت المقبض



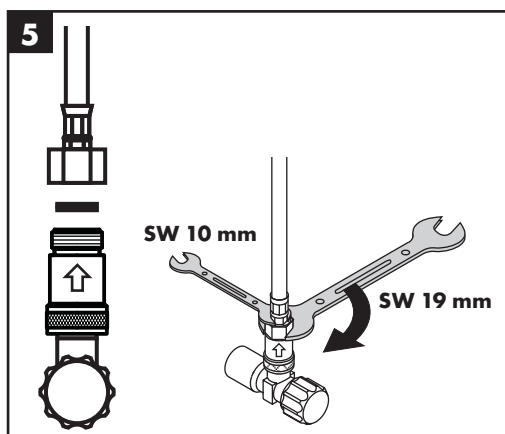
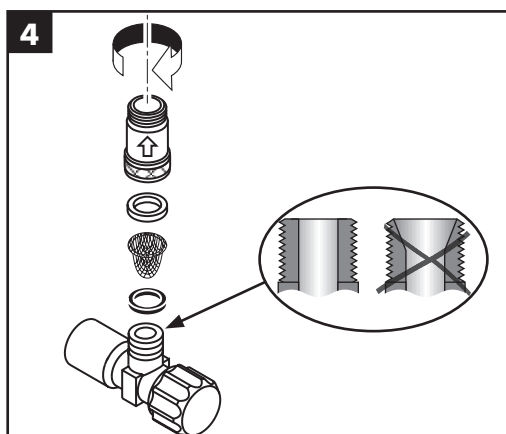
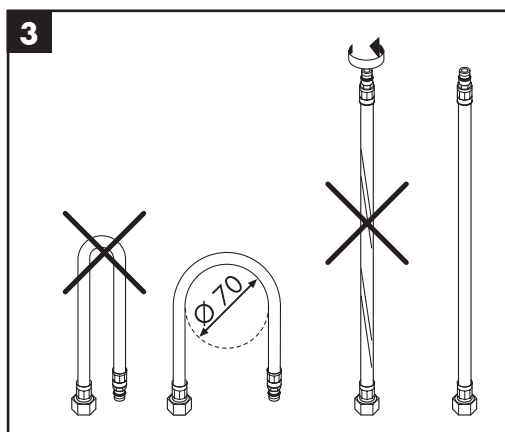
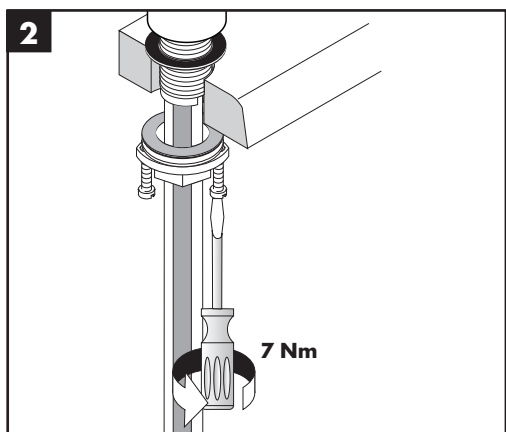
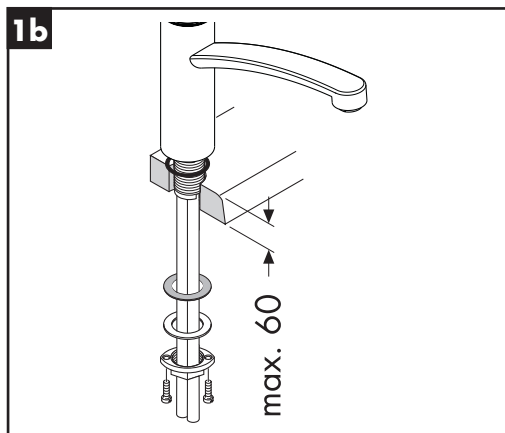
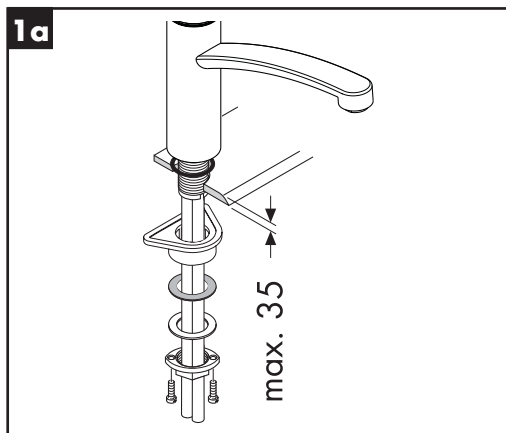



6

blau / bleu / blue / blu / azul / blauw /
 Blå / azul / niebieski / modrá / modrá /
 蓝色 / синий / kék / sininen / blå /
 mēlyna / plava / mavi / albastru / μπλε /
 أزرق / modra / sinine / zila / plava /
 blå / синьо / blu

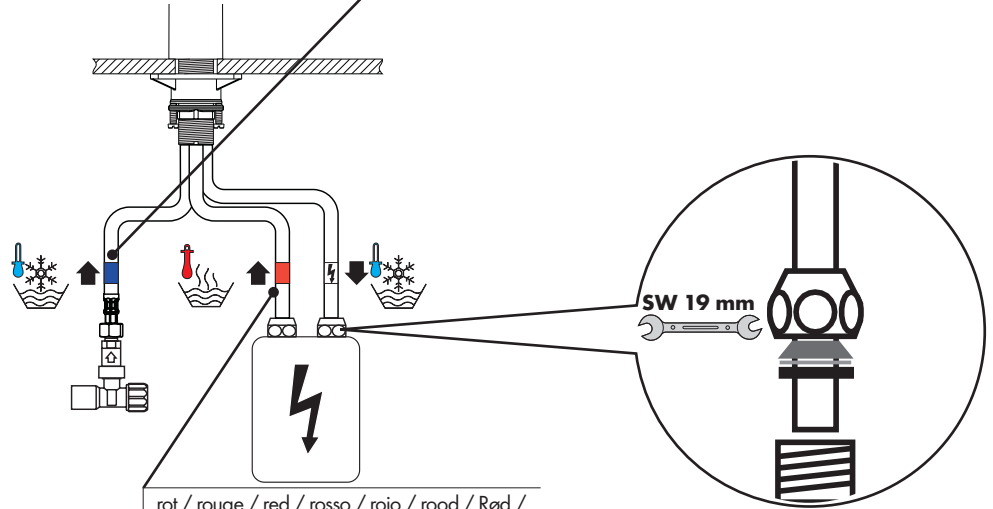

rot / rouge / red / rosso / rojo / rood / Rød /
 vermelho / czerwony / červená / červená /
 红色 / красный / piros / punainen / röd /
 raudona / crvena / kırmızı / roşu / κόκκινο /
 أحمر / rdeča / punane / sarkana / crvena /
 rød / червено / e kuqe



	P-IX	DVGW	SVGW	ACS	WRAS	NF	KIWA
31784000	P-IX 18983/1			X	X		
31785000	P-IX 18983/1			X	X		
31804000	P-IX 18983/1			X	X		



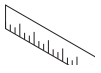

Focus E 31784000

Focus S 31785000

Focus E² 31804000

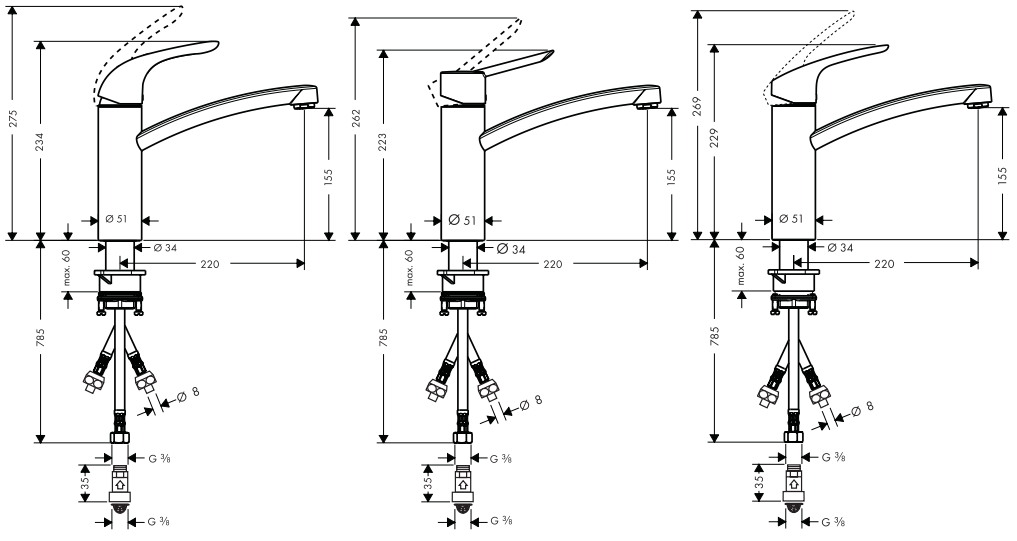

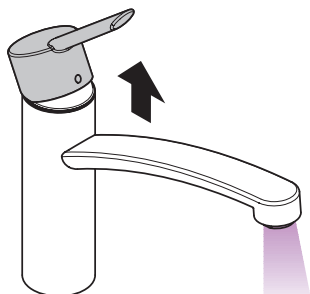

öffnen / ouvert / open / aperto / abierto / abne / abnir / otworzyć / otevřít / otvorit / 开 / открыть / nyitás / avaaaminen / öppna / atidaryti / Otvaranje / açmak / deschide / ανοικτό / odpreti / avage / atvērt / otvoriti / åpne / отварање / hare / فتح

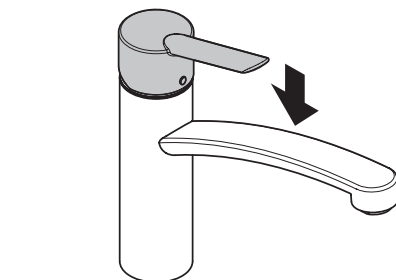

schließen / fermé / close / chiudere / cerrar / sluiten / lukke / fechar / zamknąć / zavřít / uzavriet / 关 / закрыть / bezárás / sulkeminen / stänga / uždaryti / Zatvaranje / kapatmak / închide / κλειστό / zapreti / sulgege / aizvērt / zatvori / lukke / затваряње / mbylle / إغلاق

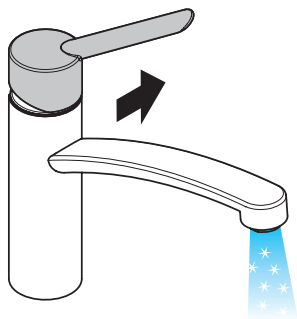

kalt / froid / cold / freddo / frío / koud / koldt / fria / zimna / studená / studená / 冷 / холодная / hideg / kylmä / kallt / šaltas / Hladno / soğuk / rece / крúо / mrzlo / külm / auksts / hladno / kaldt / студено / i ftohtë / بارد

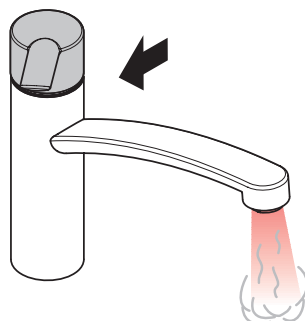

warm / chaud / hot / caldo / caliente / warm / varmt / quente / ciepła / teplá / teplá / 热 / горячая / meleg / lämmin / varmt / karštas / Vruća voda / sıcak / cald / ζεστό / toplo / kuum / karsts / topla / varm / тепло / i ngrohtë / ساخن

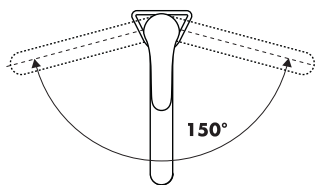



Focus E 31784000
Focus S 31785000
Focus E² 31804000

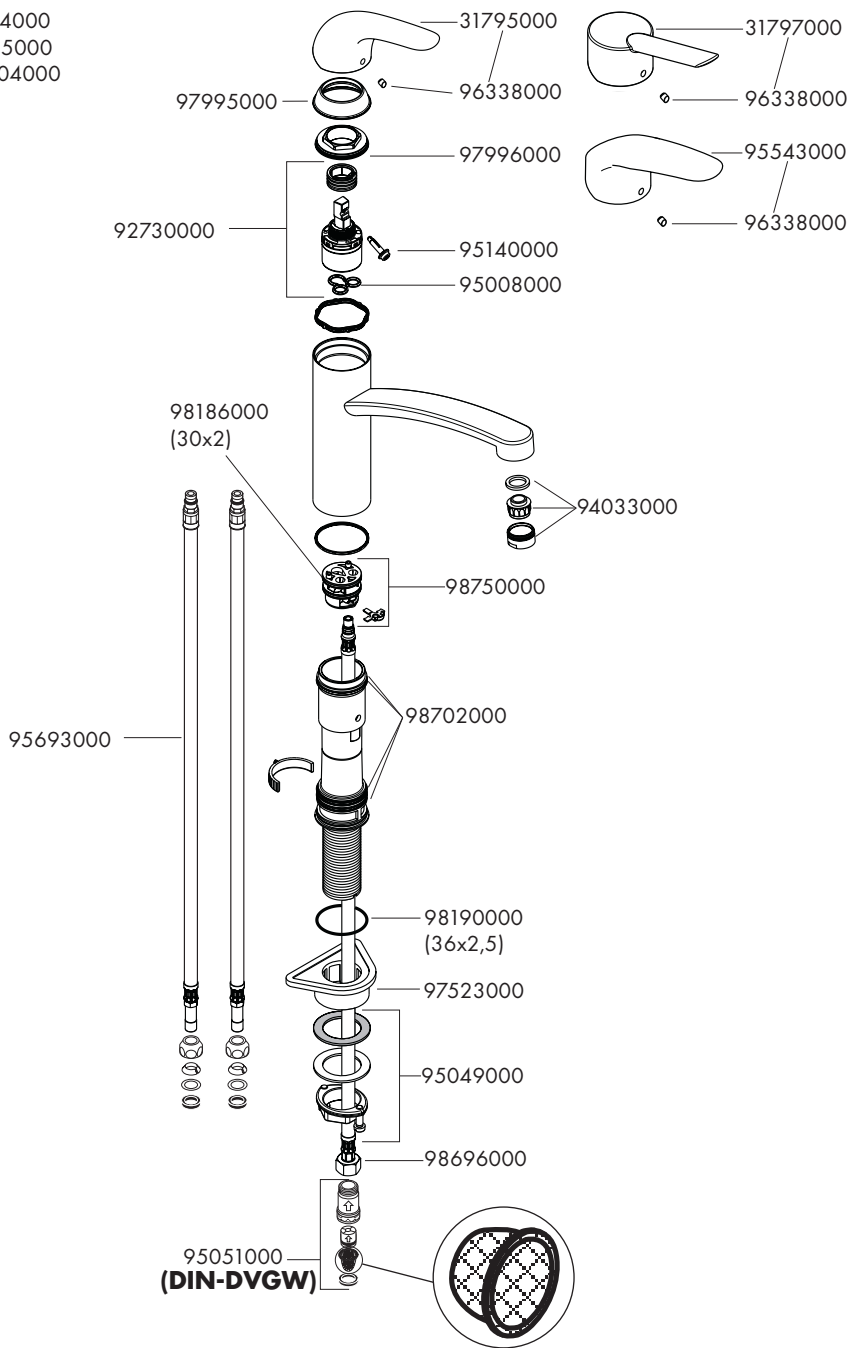

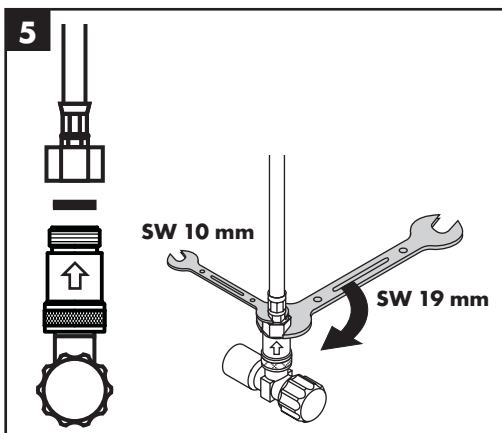
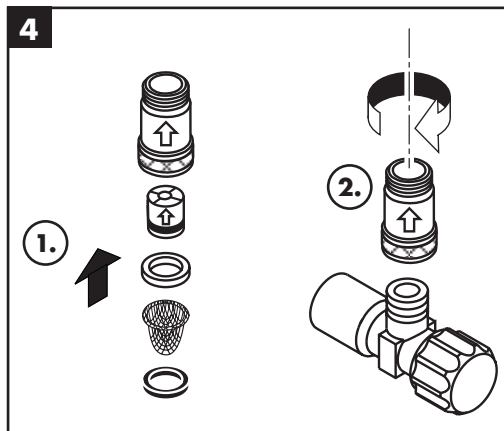
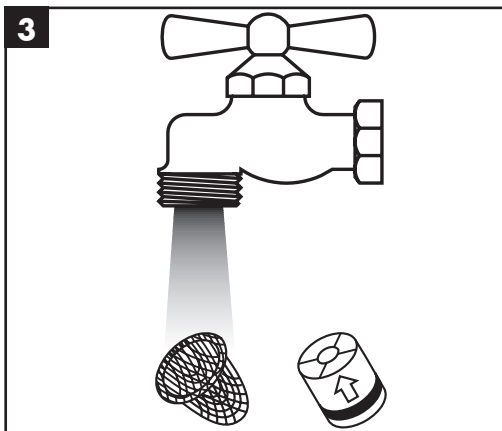
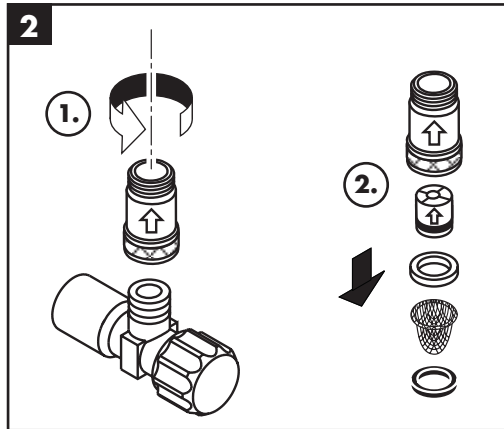
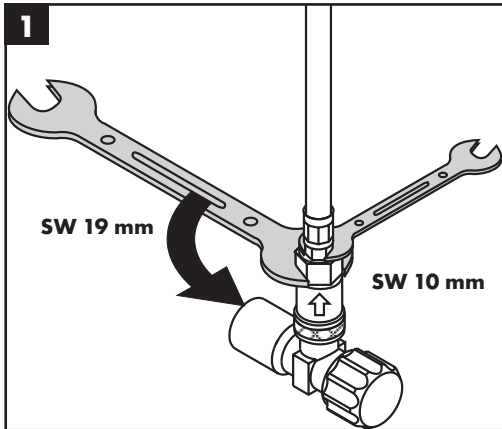

hansgrohe