



**BOSCH**

# KOSIARKA DO TRAWY

UniversalRotak 36-560 | 3 600 HB9 506

---

## Spis treści

Rysunek złożeniowy.....	2
-------------------------	---

Rysunek złożeniowy - E

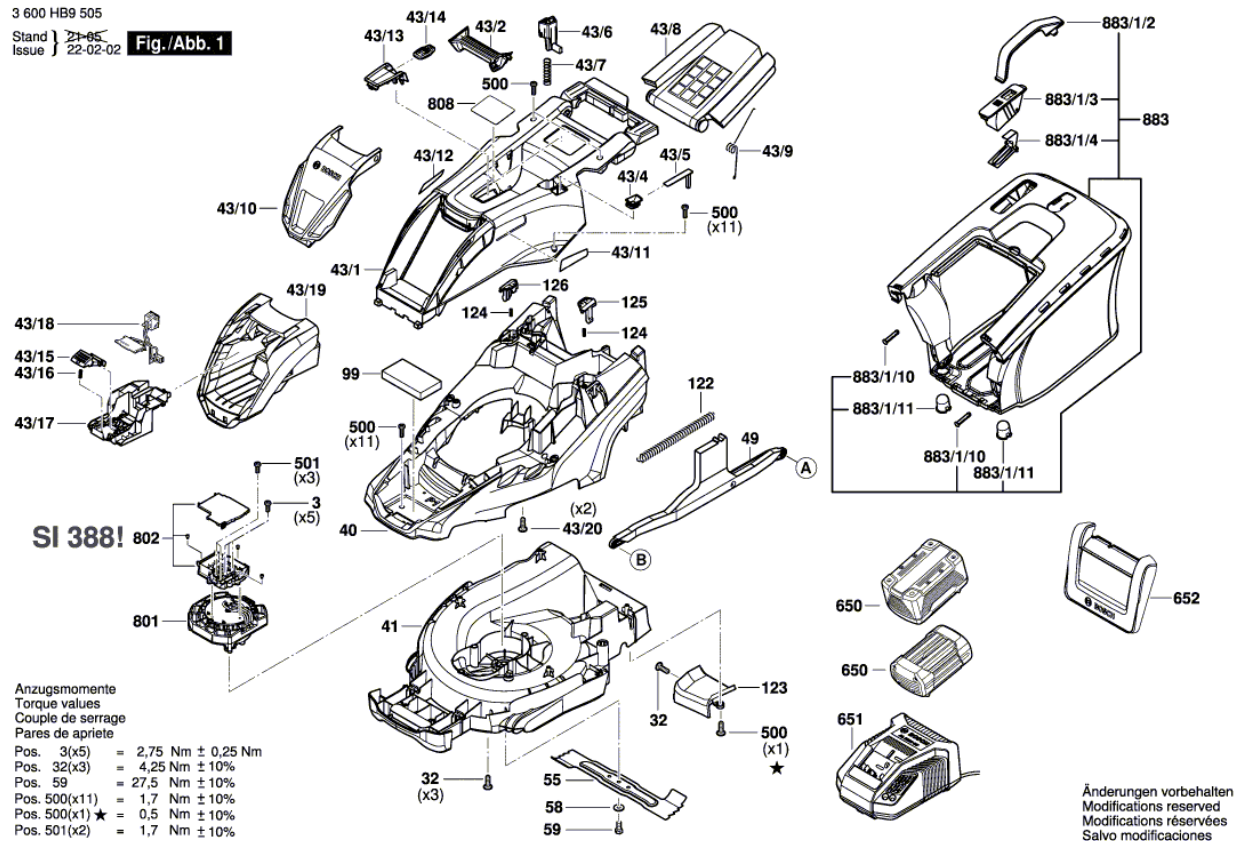

Rysunek złożeniowy - E

3 600 HB9 505  
 Stand } 21-03-11  
 Issue } 21-06-01 **Fig./Abb. 2**

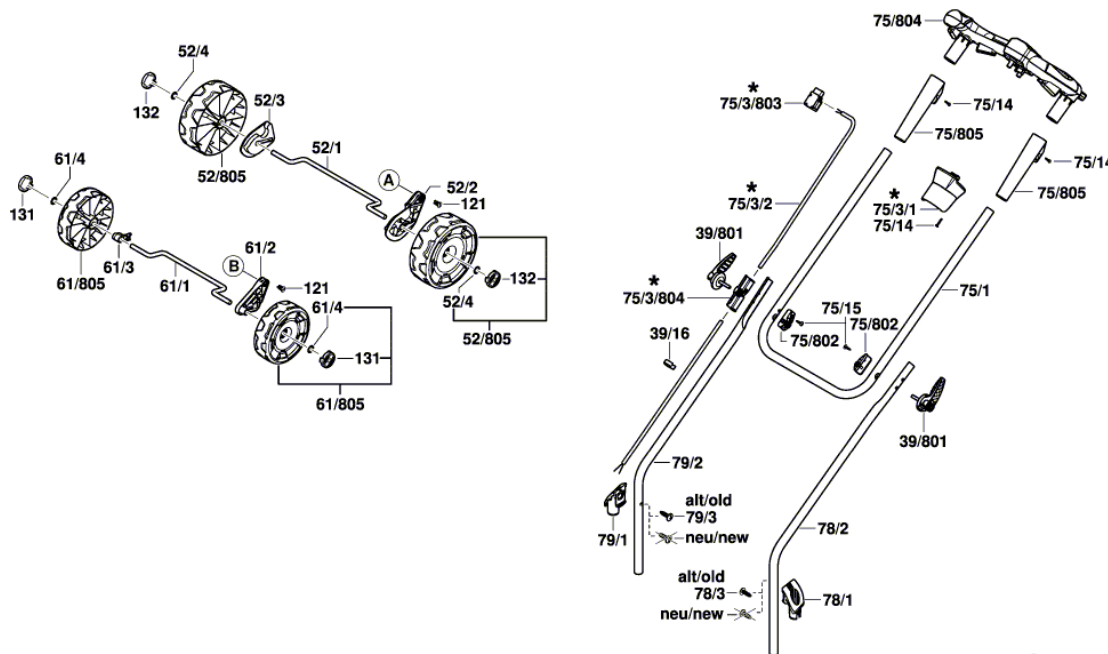

\* = Pos. 75/3

Änderungen vorbehalten  
 Modifications reserved  
 Modifications réservées  
 Salvo modificaciones