

## Wilo-Protect-Modul C

- |           |   |           |   |
|-----------|---|-----------|---|
| <b>D</b>  | Einbau- und Betriebsanleitung           | <b>E</b>  | Instrucciones de instalación y funcionamiento |
| <b>GB</b> | Installation and operating instructions | <b>I</b>  | Istruzioni di montaggio, uso e manutenzione   |
| <b>F</b>  | Notice de montage et de mise en service | <b>GR</b> | Οδηγίες εγκατάστασης και λειτουργίας          |
| <b>NL</b> | Inbouw- en bedieningsvoorschriften      |           |   |

Fig.1

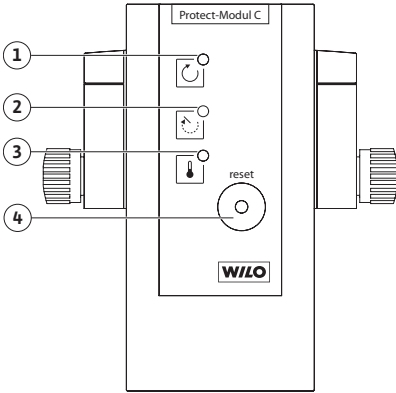

Fig.2a

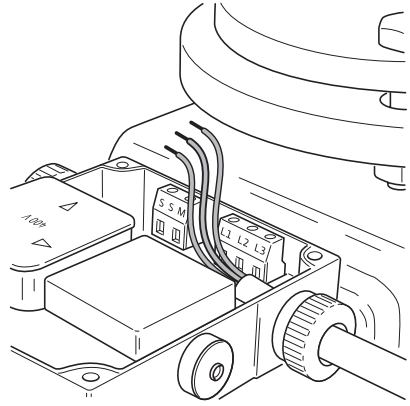

Fig.2b

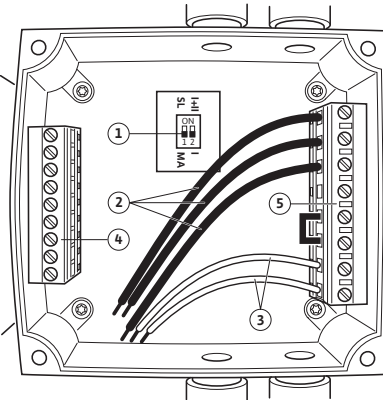

Fig.2c

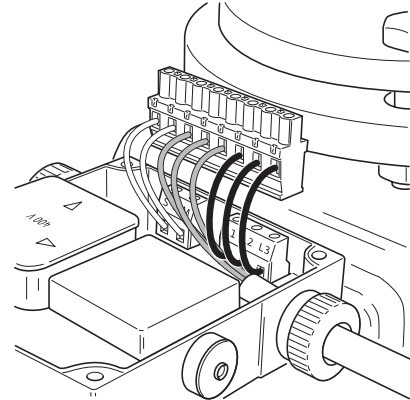

Fig.2d

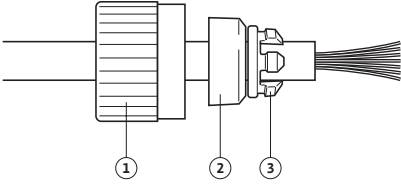

Fig.2e

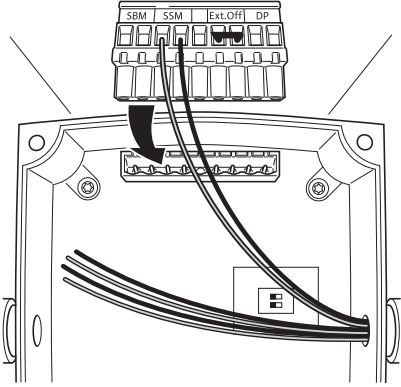

Fig.2f

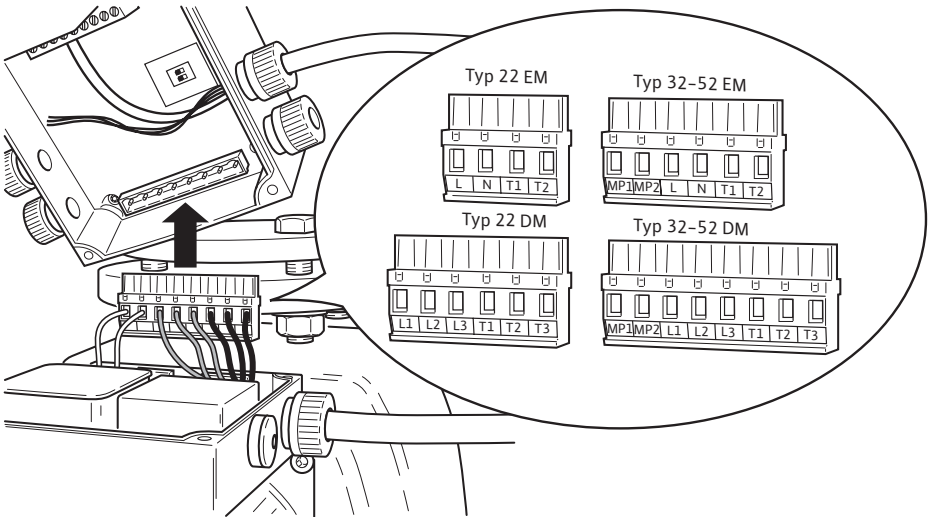

Fig.2g

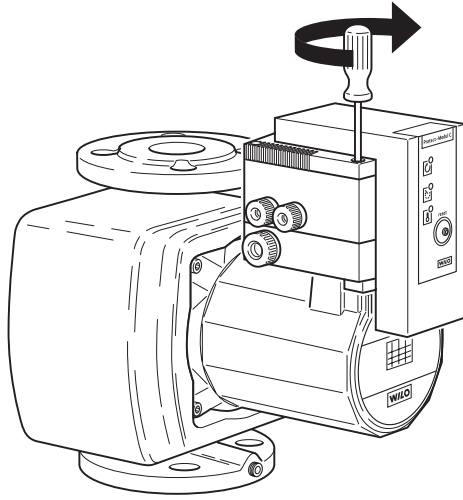

Fig.3a

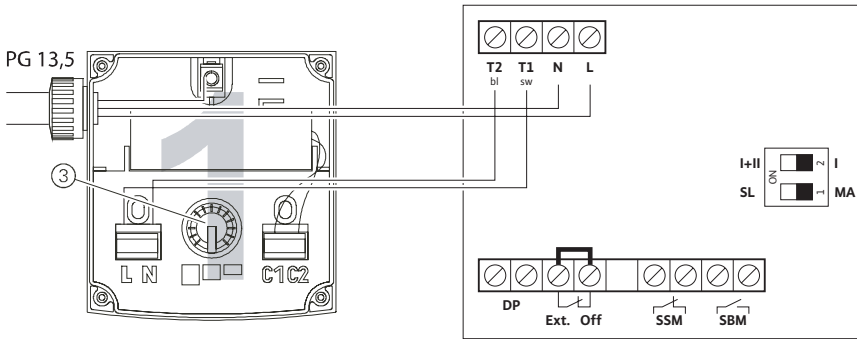

Fig.3b

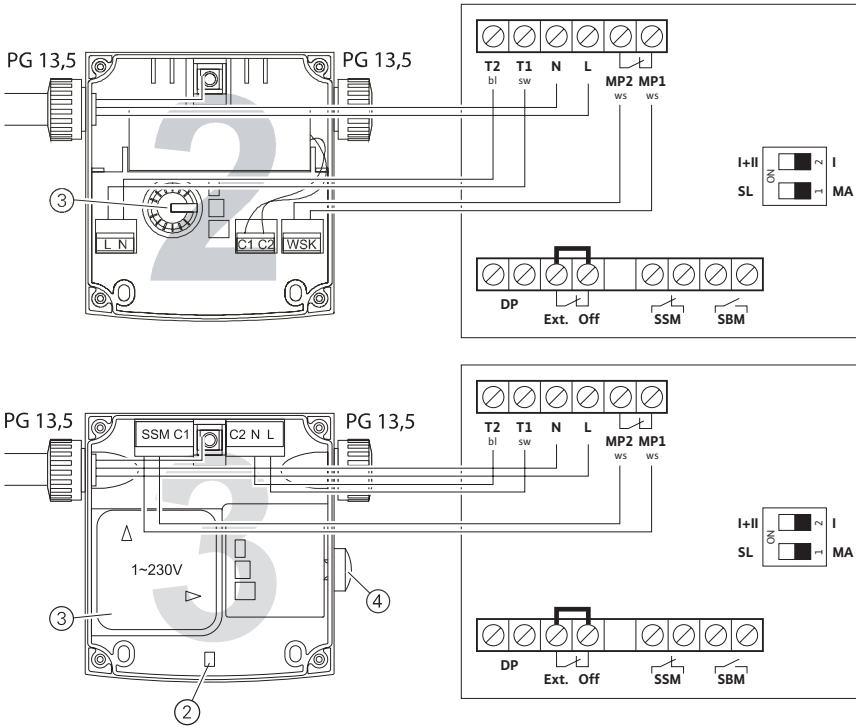

Fig.3c

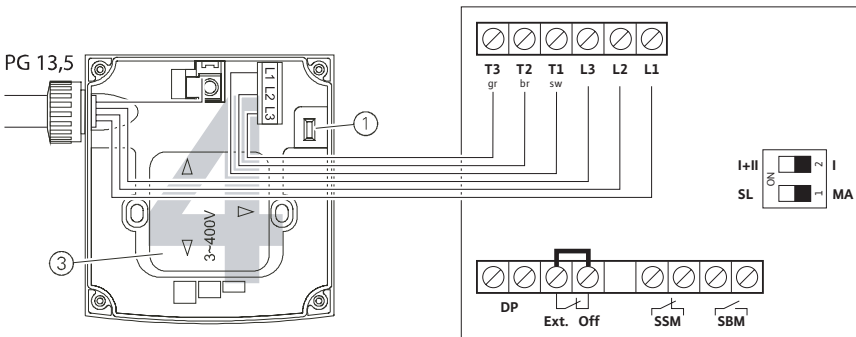

Fig.3d

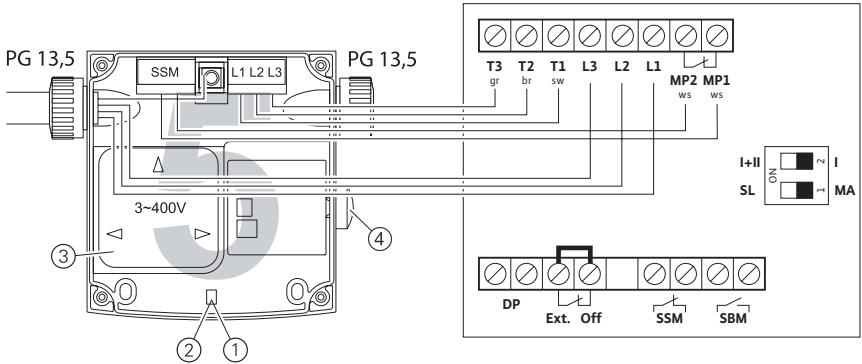
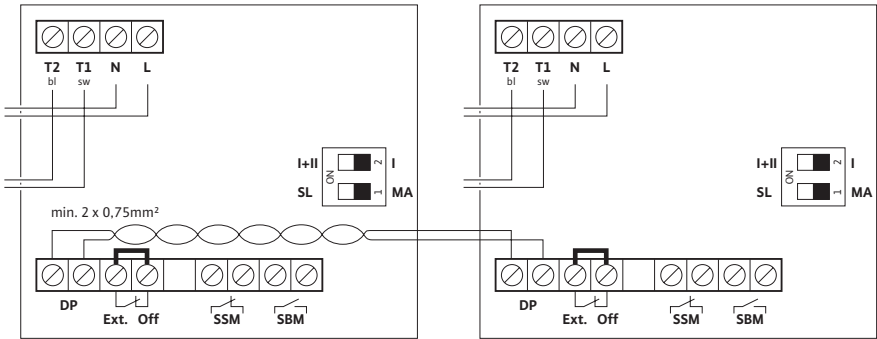

Fig.3e



<b>D</b>	Einbau- und Betriebsanleitung	3
<b>GB</b>	Installation and operating instructions	13
<b>F</b>	Notice de montage et de mise en service	23
<b>NL</b>	Inbouw- en bedieningsvoorschriften	33
<b>E</b>	Instrucciones de instalación y funcionamiento	43
<b>I</b>	Istruzioni di montaggio, uso e manutenzione	54
<b>GR</b>	Οδηγίες εγκατάστασης και λειτουργίας	65

## 1 General

### 1.1 About this document

These Installation and Operating Instructions are an integral part of the product. They must be kept readily available at the place where the product is installed. Strict adherence to these instructions is a precondition for the proper use and correct operation of the product.

These Installation and Operating Instructions correspond to the relevant version of the product and the underlying safety standards valid at the time of going to print.

**These Installation and operating instructions are an addition to the Installation and operating instructions for glandless circulation pump type TOP-S/TOP-SD/TOP-Z.**

## 2 Safety

These operating instructions contain basic information which must be adhered to during installation and operation. For this reason, these operating instructions must, without fail, be read by the service technician and the responsible operator before installation and commissioning .

It is not only the general safety instructions listed under the main point “safety” that must be adhered to but also the special safety instructions with danger symbols included under the following main points.

### 2.1 Designation of information in the operating instructions

#### Symbols:

**General danger symbol**



**Danger due to electrical voltage**



NOTE: ...



#### Signal words:

**DANGER!**

**Acutely dangerous situation.**

**Non-observance results in death or the most serious of injuries.**

#### **WARNING!**

**The user can suffer (serious) injuries. 'Warning' implies that (serious) injury to persons is probable if this information is disregarded.**



**CAUTION!**

**There is a risk of damaging the pump/unit. 'Caution' implies that damage to the product is likely if the information is disregarded.**

**NOTE:**

Useful information on using the product. It draws attention to possible problems.

**2.2 Personnel qualifications**

The installation personnel must have the appropriate qualification for this work.

**2.3 Danger in event of non-observance of the safety instructions**

Non-observance of the safety instructions can result in risk of injury to persons and damage to pump/unit. Non-observance of the safety instructions can result in the loss of any claims to damages.

In detail, non-observance can, for example, result in the following risks:

- Failure of important pump/unit functions,
- Failure of required maintenance and repair procedures
- Danger to persons from electrical, mechanical and bacteriological influences,
- Property damage

**2.4 Safety instructions for the operator**

The existing directives for accident prevention must be adhered to.

Danger from electrical current must be eliminated. Local directives or general directives [e.g. IEC, VDE etc.] and local power supply companies must be adhered to.

**2.5 Safety instructions for inspection and installation work**

The operator must ensure that all inspection and installation work is carried out by authorised and qualified personnel, who are sufficiently informed from their own detailed study of the operating instructions.

Work to the pump/unit must only be carried out when at a standstill.

**2.6 Unauthorised alteration and spare part production**

Alterations to the pump/unit are only permissible after consultation with the manufacturer. Original spare parts and accessories authorised by the manufacturer ensure safety. The use of other parts can nullify the liability from the results of their usage.

**2.7 Unacceptable operating modes**

The operating safety of the supplied pump/unit is only guaranteed for conventional use in accordance with Section 4 of the operating instructions. The limit values must on no account fall under or exceed those specified in the catalogue/data sheet.

### 3 Transport and interim storage

On receipt of the product, check it for any damage incurred in transit. In the event of damage in transit, the necessary steps must be taken with the carrier before the relevant deadlines.



**CAUTION! Danger of damage to the module!**

**Danger of damage due to improper handling during transport and storage.**

- **The Protect-Module C must be protected during transport and storage from moisture, frost and mechanical damage.**
- **It must not be exposed to any temperature outside the range - 10 °C to + 70 °C.**

### 4 Application

The TOP series circulating pumps come equipped with a standard terminal box. A retrofit plug-in module is available for the pump with the Protect-Module C (see title illustration). In addition to the pump functions, the Protect-Module C also enables further signals as well as the performance of control tasks.

**When the Protect-Module C is deployed, external contactors and supplementary switchgears are no longer required, with a corresponding effect on the complexity of the installation.**

## 5 Product data

### 5.1 Type Key

Example: Wilo-Protect-Modul C Type 22 EM	
Protect-Modul	Series designation
C	Comfort
Type 22	Type designation: 22 or 32-52
EM	For mains connection: EM = 1~230 V, 50 Hz (single-phase motor) DM = 3~400 V, 50 Hz (three-phase current motor)

## 5.2 Technical data

Technical data	
Connection current	
Type 22 EM	1~230 V, ±10 %, 50 Hz
Type 32-52 EM	1~230 V, ±10 %, 50 Hz
Type 22 DM	3~400 V, ±10 %, 50 Hz
Type 32-52 DM	3~400 V, ±10 %, 50 Hz
Frequency	50 Hz
Terminal cross-section, all terminals	max. 2.5 mm <sup>2</sup>
Temperature range of flow medium	-20 °C to +110 °C
Max. ambient temperature	+40 °C
Pump protection class	IP 44
Cable connections	4 x PG 9
Electromagnetic compatibility:	
Emitted interference	EN 61000-6-3
Immunity to interference	EN 61000-6-2

### 5.3 Scope of supply

- Protect-Module C
- Plug strip control and signal terminals
- Plug strip mains connection terminals and connection terminals WSK/SSM with connection cables
- Fixing screws (4)
- Installation and operating instructions

## 6 Description and function

### 6.1 Description of the Protect-Module C

The functions of the pump housed in the terminal box (mains connection, thermal winding contact WSK or potential-free collective fault signal) are transferred to the terminal box when the Protect-Module C is installed. The fault acknowledgement button and the direction of rotation control lamp, if fitted, as well as the manual speed stage switching of the standard terminal box continue to function when the Protect-Module C is installed.

The Protect-Module C is fitted to the standard terminal box of the pump in place of the terminal box cover.

## 6.2 Functions and operation of the Protect-Module C

### 6.2.1 Light signals

There are three possible light signals on the display field:

- Operation light signal (figure 1, position 1)



**WARNING! Danger of electric shock**

**Even when the operation light signal is off, voltage may be present on the Protect-Module.**

- Fault signal light “Stoppage” (figure 1, position 2)
- Fault signal light “Winding Overheat” (figure 1, position 3)

### 6.2.2 Fault acknowledgement buttons

- Fault acknowledgement button on the pump (figures 3b, 3d, position 4)  
If fitted, this button is used to reset the response of the integrated full motor protection. This fault reset is done before fault reset on the Protect-Module C.
- Fault acknowledgement button on Protect-Module C (figure 1, position 4)
  - A fault displayed on the Protect-Module C is reset by briefly pressing this button (< 1s).
  - Pressing and holding down the button ( $\geq 1s$ ) triggers pump cycling in dual pump operation with integrated dual pump management.

### 6.2.3 Faults, light signals, signal contacts

- Single pump

The following table shows the links between possible faults and the reactions of light signals and signal contacts:

Operating element	Status	Possible causes
Operation light signal green	off	<ul style="list-style-type: none"> <li>• No supply voltage.</li> <li>• Control input “Ext. Off” opened.</li> <li>• Fault is present and has not yet been acknowledged.</li> </ul>
	flashing	<ul style="list-style-type: none"> <li>• DP communication fault (only with double pump).</li> </ul>
Fault signal light “Stoppage” red	off	<ul style="list-style-type: none"> <li>• No motor stoppage.</li> </ul>
	on	<ul style="list-style-type: none"> <li>• Motor stoppage recognised.</li> <li>• Mechanical blockage of pump</li> <li>• Winding fault</li> </ul>
	flashing	<ul style="list-style-type: none"> <li>• Motor stoppage acknowledged, pump is in control loop <sup>1)</sup>.</li> </ul>
Fault signal light “Winding Overheat” red	off	<ul style="list-style-type: none"> <li>• No overheat.</li> </ul>
	on	<ul style="list-style-type: none"> <li>• Overheat recognised.</li> <li>• Pump overload</li> <li>• Winding fault</li> <li>• Unacceptable combination of medium temperature – ambient temperature</li> </ul>
	flashing	<ul style="list-style-type: none"> <li>• Overheat acknowledged, pump is in control loop <sup>1)</sup>.</li> </ul>
Operating signal contact	open	<ul style="list-style-type: none"> <li>• No supply voltage.</li> <li>• Control input “Ext. Off” opened.</li> <li>• Fault is present and has not yet been acknowledged.</li> </ul>
	closed	<ul style="list-style-type: none"> <li>• Pump functioning, no fault recognised.</li> </ul>
Fault signal contact	open	<ul style="list-style-type: none"> <li>• Fault is present.</li> <li>• Pump is still in control loop <sup>1)</sup>.</li> </ul>
	closed	<ul style="list-style-type: none"> <li>• Fault-free operation.</li> </ul>
Fault signal light “Stoppage” red	off	<ul style="list-style-type: none"> <li>• No motor stoppage.</li> </ul>
	on	<ul style="list-style-type: none"> <li>• Motor stoppage recognised.</li> <li>• Mechanical blockage of pump.</li> <li>• Winding fault.</li> </ul>

<sup>1)</sup> After acknowledging a fault, the Protect-Module C will be in a special control loop for up to 10 sec, depending on pump type and fault. If the fault is recognised again during this process, the pump returns to fault status.

Table 1

- Double pump:  
The relationships between possible faults and the reactions of light signals and signal contacts depend on the following factors:
  - Parametrisation of signal contacts in individual operation/individual fault signal or joint operation/collective fault signal (function see Table 2)
  - Allocation of “Ext. Off” control inputs to master and slave

### 6.2.4 Double pump operation

A Protect-Module C must be installed for each of the two pumps.

The double pump functions on the Protect-Module C are:

- Main/Reserve operation with automatic switching to the standby reserve pump after 24 hours of real running time, the external control command "Ext. Off" interrupts the running time counter.
- Switching takes place through an overlap, i.e. at the time of switching, both pumps run simultaneously (for approx. 10 sec.). This avoids pressure surges and undersupply in cooling and air-conditioning systems for example.
- The DIP switch 1 (figure 2b, position 1) determines which pump is the master (MA) and which pump is the slave (SL) (function see Table 2).
- The DIP switch 2 (figure 2b, position 1) determines whether the signal contacts "SSM" and "SBM" are individual or collective signals (function see Table 2).
- In the case of a fault in the working pump, the system switches to the standby pump after approx. 3 sec.

Single pump	Double pump	
	Master (MA)	Slave (SL)
DIP Switch1: MA	DIP Switch1: MA	DIP Switch1: SL
DIP Switch2: I	DIP Switch2: -	DIP Switch2: -
Allocate terminals to Ext. Off	Allocate terminals to Ext. Off	Bridge terminals to Ext. Off
DIP Switch1: MA	DIP Switch1: MA	DIP Switch1: SL
DIP Switch2: I	DIP Switch2: I	DIP Switch2: -
SSM: Collective fault signal for pump	SSM: Individual fault signal for MA DIP Switch2: I + II SSM: Collective fault signal for MA + SL	SSM: Individual fault signal for SL DIP Switch2: - SSM: Individual fault signal for SL
DIP Switch1: MA	DIP Switch1: MA	DIP Switch1: SL
DIP Switch2: I	DIP Switch2: I	DIP Switch2: -
SBM: Individual operating signal for pump	SBM: Individual operating signal for MA DIP Switch2: I + II SBM: Collective operating signal for MA + SL	SBM: Individual operating signal for SL DIP Switch2: - SBM: Individual operating signal for SL
- : Setting of DIP switch not relevant		

Table 2

## 7 Installation and electrical connection

Installation and electrical connection must be carried out in accordance with local regulations and only by qualified personnel.



**WARNING! Danger of personal injury**

The applicable regulations on the prevention of accidents must be observed.



**WARNING! Danger of electric shock**

Potential dangers from electrical currents must be eliminated.

Local directives or general regulations [e.g. IEC, VDE etc.] and those issued by the local power supply company must be adhered to.

### 7.1 Installation and electrical connection of mains cable

1. Switch off power supply to pump,



**CAUTION! Danger of damage to Protect-Module C**

The module may only be plugged in and unplugged when the pump has been completely disconnected.

2. Loosen the terminal box lid screws on the pump,

3. Remove terminal box lid,

4. Pinch off power supply cable except the protective lead PE:

EM version (1~230V): L, N

DM version (3~400V) L1, L2, L3 (figure 2a)

5. Remove plug strip with power supply terminals and connection terminals MP1/MP2 (figure 2b, position 5) with connection cables (figure 2b, position. 2.3) from the Protect-Module C. When removing, do not pull straight out, but begin at one corner of the plug strip,

6. Apply the plug strip cables to the corresponding terminals on the pump terminal box (figure 2c, figure 3),

7. Fit power supply cable to the plug strip, Table 3 shows the allocation of module types to the terminal diagrams.

Protect-Module C	Terminal diagram
Type 22 EM	3a
Type 32-52 EM	3b
Type 22 DM	3c
Type 32-52 DM	3d

Table 3

8. Remove the plug strip with control and signal terminals (figure 2b, position 4) from the Protect-Module C. When removing, do not pull straight out, but begin at one corner of the plug strip,
- 8.1 Dismantle cable connection (PG 9) of the Protect-Module C,
  - 8.2 Cut diaphragm seal,

- 8.3 Thread individual parts of the cable connection onto the control cable (figure 2d),
  - Pos. 1: Union connection
  - Pos. 2: Seal
  - Pos. 3: Strain relief
- 8.4 Insert control cable through cable connection into Protect-Module C,
- 8.5 Assemble cable connection, fastening union nuts tightly enough so that the cable can no longer be pulled out of the cable connection by hand.



**CAUTION! Danger of damage to Protect-Module C**

**An incorrectly assembled cable connection may lead to a short-circuit in the module due to water penetration. This is a particular danger in cold water installations in which condensation constantly forms.**

9. Fix control cable to the plug strip (figure 2 e),
10. Plug the plug strip with control cable to the corresponding place in the Protect-Module C,
11. Set DIP switch (figure 2b, position 1) in accordance with Table 2,
12. Plug the Protect-Module C on to the plug strip with the power connections (figure 2f),



Note: Arrange power cables and leads so that they cannot be crushed when finally tightening the module installation.

In DM versions, it is essential before final tightening of the module installation to check the direction of rotation with the direction of rotation control lamp in the pump terminal box (figures 3c, 3d, position 1).

13. Arrange the Protect-Module C over the terminal box structure and screw to the domes of the terminal box using the screws provided, tighten screws evenly diagonally (figure 2g).
- Stages 1 to 4 are not required for a new installation. Power connection is made directly on the corresponding plug strip with power connection terminals and connection terminals MP1/MP2.
  - For a double pump, as previously described, two Protect-Modules C must be fitted. For integrated dual pump management, the DP terminals of the two Protect-Modules C must be connected to each other, see also figure 3e.

## 7.2 Electrical connection of control and signal clamps

For connection to a remote control centre or building automation, the following connections are provided:

- **Ext. Off:** Control input with “drive priority off” for potential-free normally closed contacts, contact charge 24V, 10 mA.  
In dual pump operation, Ext. Off on the master must be assigned to a potential-free normally closed contact, and Ext. Off on the slave must remain bridged. The Ext. Off of the master works on the entire double pump, i.e. master and slave.
- **SBM:** Programmable run signal, potential-free normally opened contact, maximum contact capacity 250 VAC, 1 A.



- **SSM:** Programmable fault signal, potential-free normally closed contact, maximum contact capacity 250 VAC, 1 A.

A serial interface is provided for integrated dual pump management:

- **DP:** Interface for integrated dual pump management, the connection terminals cannot be twisted. The connection cable ( $2 \times 0/75 \text{ mm}^2$ ) must be provided on site. Wiring for all Protect-Modules is shown in the example in figure 3e.

## 8 Commissioning



**CAUTION! Danger of damage to Protect-Module C**

**When commissioning, the installation and operating instructions of the glandless circulation pump, types TOP-S/TOP-SD/TOP-Z must be observed.**



NOTE: Rotation control (only for three-phase motors)

In pumps with three-phase connection, before final tightening of the module installation, it is essential to check the direction of rotation with the direction of rotation control lamp in the pump terminal box (figures 3c, 3d, position 1).

- When the Protect-Module C is fully installed, switch on power supply.

## 9 Maintenance

**Maintenance and repair work must only be carried out by professionally qualified personnel.**



**WARNING! Danger of electric shock**

**Potential dangers from electrical currents must be eliminated.**

**During all maintenance and repair work, the pump must be disconnected from the power supply and secured against possible unauthorised reconnection.**

## 10 Faults, causes and remedies

see paragraph 6.2

**If an operating fault of the pump / the Protect-Module C / system cannot be corrected, please consult a professional technician or contact your nearest Wilo Customer Service point or representative.**

## 11 Spare parts

Spare parts may be ordered through local professional technicians and/or Wilo Customer Service.

To avoid queries and order errors, all data on the rating plate must be given along with every order.

**Subject to technical changes!**

## Wilo – International (Subsidiaries)

### Austria

WILO Handelsges. m.b.H.  
 1230 Wien  
 T +43 1 25062-0  
 F +43 1 25062-15  
 office@wilo.at

### Belarus

WILO Bel OOO  
 220035 Minsk  
 T +375 17 2503383  
 wilibel@mail.ru

### Belgium

WILO NV/SA  
 1083 Ganshoren  
 T +32 2 4823333  
 F +32 2 4823330  
 info@wilo.be

### Bulgaria

WILO Bulgaria EOOD  
 1125 Sofia  
 T +359 2 9701970  
 F +359 2 9701979  
 info@wilo.bg

### Canada

WILO Canada Inc.  
 Calgary, Alberta T2A5L4  
 T +1 403 2769456  
 F +1 403 2779456  
 blowe@wilo-na.com

### China

WILO SALSMON (Beijing)  
 Pumps System Ltd.  
 101300 Beijing  
 T +86 10 804939700  
 F +86 10 80493788  
 wilobj@wilo.com.cn

### Czech Republic

WILO Praha s.r.o.  
 25101 Cestlice  
 T +420 234 098 711  
 F +420 234 098 710  
 info@wilo.cz

### Denmark

WILO Danmark A/S  
 2690 Karlslunde  
 T +45 70 253312  
 F +45 70 253316  
 wilo@wilo.dk

### Finland

WILO Finland OY  
 02320 Espoo  
 T +358 9 26065222  
 F +358 9 26065220  
 wilo@wilo.fi

### France

WILO S.A.S.  
 78310 Coignières  
 T +33 1 30050930  
 F +33 1 34614959  
 wilo@wilo.fr

### Great Britain

WILO SALSMON Pumps Ltd.  
 DE14 2WJ Burton-on-Trent  
 T +44 1283 523000  
 F +44 1283 523099  
 sales@wilo.co.uk

### Greece

WILO Hellas AG  
 14569 Anixi (Attika)  
 T +30 10 6248300  
 F +30 10 6248360  
 wilo.info@wilo.gr

### Hungary

WILO Magyarország Kft  
 1144 Budapest XIV  
 T +36 1 46770-70 Sales Dep.  
 46770-80 Tech. Serv.  
 F +36 1 4677089  
 wilo@wilo.hu

### Ireland

WILO Engineering Ltd.  
 Limerick  
 T +353 61 227566  
 F +353 61 229017  
 sales@wilo.ie

### Italy

WILO Italia s.r.l.  
 20068 Peschiera Borromeo  
 (Milano)  
 T +39 02 5538351  
 F +39 02 55303374  
 wilo.italia@wilo.it

### Kazakhstan

TOO WILO Central Asia  
 480100 Almaty  
 T +7 3272 507333  
 F +7 3272 507332  
 info@wilo.kz

### Korea

WILO Industries Ltd.  
 137-818 Seoul  
 T +82 2 34716600  
 F +82 2 34710232  
 wilo@wilo.co.kr

### Latvia

WILO Baltic SIA  
 1019 Riga  
 T +371 7 145229  
 F +371 7 145566  
 mail@wilo.lv

### Lebanon

WILO SALSMON  
 Lebanon s.a.r.l.  
 10222030 El Metn  
 T +961 4 722280  
 F +961 4 722285  
 wsl@cyberia.net.lb

### Lithuania

UAB WILO Lietuva  
 03202 Vilnius  
 T +370 2 236495  
 F +370 2 236495  
 mail@wilo.lt

### The Netherlands

WILO Nederland b.v.  
 1948 RC Beverwijk  
 T +31 251 220844  
 F +31 251 225168  
 wilo@wilo.nl

### Norway

WILO Norge A/S  
 0901 Oslo  
 T +47 22 804570  
 F +47 22 804590  
 wilo@wilo.no

### Poland

WILO Polska Sp. z o.o.  
 05-090 Raszyn k/Warszawy  
 T +48 22 7201111  
 F +48 22 7200526  
 wilo@wilo.pl

### Portugal

Bombas Wilo-Salmsom  
 Portugal  
 4050-040 Porto  
 T +351 22 2080350  
 F +351 22 2001469  
 bombas@wilo-salmsom.pt

### Romania

WILO Romania s.r.l.  
 7000 Bucuresti  
 T +40 21 4600612  
 F +40 21 4600743  
 info@wilo.ro

### Russia

WILO Rus o.o.o.  
 1235912 Moskau  
 T +7 095 7810690  
 F +7 095 7810691  
 wilo@otr.ru

### Serbia & Montenegro

WILO Beograd d.o.o.  
 11000 Beograd  
 T +381 11 765871  
 F +381 11 3292306  
 dragan.simonovic@wilo.co.yu

### Slovakia

WILO Slovakia s.r.o.  
 82008 Bratislava 28  
 T +421 2 4520122  
 F +421 2 45246471  
 wilo@wilo.sk

### Slovenia

WILO Adriatic d.o.o.  
 1000 Ljubljana  
 T +386 1 5838130  
 F +386 1 5838138  
 detlef.schilla@wilo.si

### Spain

WILO Ibérica S.A.  
 28806 Alcalá de Henares  
 (Madrid)  
 T +34 91 8797100  
 F +34 91 8797101  
 wilo.iberica@wilo.es

### Sweden

WILO Sverige AB  
 35033 Växjö  
 T +46 470 727600  
 F +46 470 727644  
 wilo@wilo.se

### Switzerland

EMB Pumpen AG  
 4310 Rheinfelden  
 T +41 61 8368020  
 F +41 61 8368021  
 info@emb-pumpen.ch

### Turkey

WILO Pompa Sistemleri  
 San. ve Tic. A.Ş.  
 34530 Istanbul  
 T +90 216 6610211  
 F +90 216 6610214  
 wilo@wilo.com.tr

### Ukraine

WILO Ukraina t.o.w.  
 01033 Kiev  
 T +38 044 2011870  
 F +38 044 2011877  
 wilo@wilo.ua

### USA

WILO USA LLC  
 Calgary, Alberta T2A5L4  
 T +1 403 2769456  
 F +1 403 2779456  
 blowe@wilo-na.com

## Wilo – International (Representation offices)

### Azerbaijan

370141 Baku  
 T +994 50 2100890  
 F +994 12 4975253  
 info@wilo.az

### Bosnia and Herzegovina

71000 Sarajevo  
 T +387 33 714511  
 F +387 33 714510  
 anton.mrak@wilo.si

### Croatia

10000 Zagreb  
 T +385 1 3680474  
 F +385 1 3680476  
 rino.kerekovic@wilo.hr

### Georgia

38000 Tbilisi  
 T/F +995 32 536459  
 info@wilo.ge

### Macedonia

1000 Skopje  
 T/F +389 2122058  
 valerij.vojneski@wilo.com.mk

### Moldova

2012 Chisinau  
 T/F +373 22 223501  
 sergiu.zagurean@wilo.md

### Tajikistan

734025 Dushanbe  
 T +992 372 316275  
 info@wilo.tj

### Uzbekistan

700029 Taschkent  
 T/F +998 71 1206774  
 wilo.uz@online.ru

März 2005

## Wilo-Vertriebsbüros

### G1 Nord

WILO AG  
Vertriebsbüro Hamburg  
Sinstorfer Kirchweg 74-92  
21077 Hamburg  
T 040 5559490  
F 040 55594949

### G2 Ost

WILO AG  
Vertriebsbüro Berlin  
Juliusstraße 52-53  
12051 Berlin-Neukölln  
T 030 6289370  
F 030 62893770

### Zentrale Auftrags- bearbeitung für den Fachgroßhandel

WILO AG  
Auftragsbearbeitung  
Nortkirchenstraße 100  
44263 Dortmund  
T 0231 4102-0  
F 0231 4102-7555

### Wilo-Kompetenz-Team

- Antworten auf alle Fragen rund um das Produkt, Lieferzeiten, Versand, Verkaufspreise
- Abwicklung Ihrer Aufträge
- Ersatzteilbestellungen – mit 24-Stunden-Lieferzeit für alle gängigen Ersatzteile
- Versand von Informationsmaterial

T 01805 R-U-F-W-I-L-O\*  
7-8-3-9-4-5-6  
F 0231 4102-7666**Werktags erreichbar  
von 7-18 Uhr**

### G3 Sachsen/Thüringen

WILO AG  
Vertriebsbüro Dresden  
Frankenring 8  
01723 Kesselsdorf  
T 035204 7050  
F 035204 70570

### G4 Südost

WILO AG  
Vertriebsbüro München  
Landshuter Straße 20  
85716 Unterschleißheim  
T 089 4200090  
F 089 42000944

### Wilo-Kundendienst

WILO AG  
Wilo-Service-Center  
Nortkirchenstraße 100  
44263 Dortmund  
  
- Kundendienststeuerung  
- Wartung und  
Inbetriebnahme  
- Werksreparaturen  
- ErsatzteilberatungT 01805 W-I-L-O-K-D\*  
9-4-5-6-5-3  
0231 4102-7900  
F 0231 4102-7126**Werktags erreichbar von  
7-17 Uhr, ansonsten  
elektronische Bereit-  
schaft mit  
Rückruf-Garantie!**

### G5 Südwest

WILO AG  
Vertriebsbüro Stuttgart  
Hertichstraße 10  
71229 Leonberg  
T 07152 94710  
F 07152 947141

### G6 Rhein-Main

WILO AG  
Vertriebsbüro Frankfurt  
An den drei Hasen 31  
61440 Oberursel/Ts.  
T 06171 70460  
F 06171 704665

### Wilo-International

#### Österreich

Zentrale Wien:  
WILO Handels-  
gesellschaft mbH  
Eitnergasse 13  
1230 Wien  
T +43 1 25062-0  
F +43 1 25062-15Vertriebsbüro Salzburg:  
Gnigler Straße 56  
5020 Salzburg  
T +43 662 8716410  
F +43 662 878470Vertriebsbüro  
Oberösterreich:  
Trattnachtalstraße 7  
4710 Grieskirchen  
T +43 7248 65051  
F +43 7248 65054

#### Schweiz

EMB Pumpen AG  
Gerstenweg 7  
4310 Rheinfelden  
T +41 61 8368020  
F +41 61 8368021

### G7 West

WILO AG  
Vertriebsbüro Düsseldorf  
Hans-Sachs-Straße 4  
40721 Hilden  
T 02103 90920  
F 02103 909215

### G8 Nordwest

WILO AG  
Vertriebsbüro Hannover  
Ahrensburger Straße 1  
30659 Hannover-Lahe  
T 0511 438840  
F 0511 4388444

### Standorte weiterer Tochtergesellschaften

Belarus, Belgien, Bulgarien,  
China, Dänemark,  
Finnland, Frankreich,  
Griechenland,  
Großbritannien, Irland,  
Italien, Kanada,  
Kasachstan, Korea,  
Libanon, Litauen, Lettland,  
Niederlande, Norwegen,  
Polen, Rumänien,  
Russland, Schweden,  
Serbien & Montenegro,  
Slowakei, Slowenien,  
Spanien, Tschechien,  
Türkei, Ukraine, UngarnDie Adressen finden Sie  
unter [www.wilo.de](http://www.wilo.de) oder  
[www.wilo.com](http://www.wilo.com).